

**Report By:**

National TAB  
1329 E. KEMPER ROAD  
SUITE 4210  
CINCINNATI, OH 45246



**Report: TAB Report**  
**Function: Test, Adjust, & Balance**  
**Date: 02/10/2026**  
**Completed By: National TAB**

**PROJECT**  
**02-02-26 QT #1403 PHOENIX, AZ**

1550 E BASELINE RD

PHOENIX, AZ

**Client**

QUIKTRIP  
4705 SOUTH 129TH EAST AVENUE  
TULSA, OK 74134

# National TAB

Project: 02-02-26 QT #1403 PHOENIX, AZ

## Table Of Contents

<b>Section</b>	<b>Page #</b>
SUMMARY	3
REMARKS	4
BALANCE SCHEDULE	10
CHECKLISTS	11
RTU-1	19
RTU-2	21
RTU-3	22
EF-1 - Exhaust	24
EF-2 - Exhaust	26
COMBI-OVEN	27
EF-3 - Hood Exhaust	29
Kitchen Hood Type I	31
GRD Layout	32



# National TAB

Project: 02-02-26 QT #1403 PHOENIX, AZ  
Function: Test, Adjust, & Balance

## Project Summary

### Project Summary

The summary below provides a quick understanding of our scope of work and general testing procedures. Enclosed in the report are further details about your building performance including recommendations, asset data, and pictures. Our focus is to work with the trades to remedy any issues or deficiencies during the actual field balancing and not after the balancing has occurred to achieve a positive environment and outcome. The level of success is determined by the availability of the trades, possible parts needed, or time constraints.

### RTU's (Roof Top Units)

Each of the RTU's was measured with a flow hood to establish total flow. The total flow was then adjusted via the VFD so that airflow fell within design tolerances. All diffusers on the kitchen RTU were balanced to the engineer's design flow. The diffusers on the sales floor were only adjusted when there were noticeable issues present like drafting or dampers that were found completely closed. The Hoods On outside air rate was set by first establishing the typical QT set point at the Emerson controller and then making manually adjustments on the roof. The hoods off airflow setpoint was found by adjusting the damper position at the Emerson controller until the design airflow was achieved. Outside air was measured by reading the intake air opening with a velocity grid and multiplying by the free area. After completion of TAB all overrides were released.

### Kitchen Exhaust Hood & Associated Fans

The kitchen exhaust fan was measured at the hood filter bay utilizing a velocity matrix and a manufacturer's correction factor. Each filter velocity is multiplied by the manufacturer's corrected area. The sum of these readings equals the total flow of the exhaust fans. The total flow of the exhaust was then adjusted to within tolerance of the design flow.

### Restroom Exhaust Fans

The restroom exhaust fans were measured with a flow hood. The total flow was balanced for the fan with the exception of the new grille over the combi-oven, which was balanced to the listed design.

### Final Building Tests

After completing the test and balance the final building pressure was measured. It was confirmed that the building pressure fell within acceptable tolerances and that the pressure measurement coincides with the actual and design net airflow. Any deviations from these standards are noted throughout the report. The hood capture was tested at the perimeter of the hood and the cook top level with the equipment heat on to ensure satisfactory hood capture and containment.

## Issue List

- ALL UNITS - DUCT SMOKE DETECTOR FAIL
- BACKDRAFT DAMPERS NOT INSTALLED
- EF3 NOT PROPERLY INSTALLED
- INACCESSIBLE DAMPER
- KINKED/RESTRICTED DUCT



**02-02-26 QT #1403 PHOENIX, AZ**

**Project Issue Information**

**Issue Name :** ALL UNITS - DUCT SMOKE DETECTOR FAIL  
**Description :** In RTU1 and 3, Sensor 1 is attached to the duct smoke detector (in blower/compressor compartment). It shows a blinking amber light which means maintenance is required, and they fail the magnet trip test. In RTU2, Sensor 2 is attached to the duct smoke detector, and it shows a solid amber light which means 'Trouble', and failed magnet trip test.

**Created By :** National TAB                      **Assigned To :** National TAB - Dan Hertenstein

**Status :** Open

**Priority :** Urgent                                      **Asset Tag :**

**Originated Date :** 02/05/2026 - Christine Weale - National TAB

**02-02-26 QT #1403 PHOENIX, AZ**

**Project Issue Information**

**Issue Name :** BACKDRAFT DAMPERS NOT INSTALLED  
**Description :** Both EF1 and EF2 should have backdraft dampers, neither do.  
**Created By :** National TAB **Assigned To :** National TAB - Dan Hertenstein  
**Status :** Open  
**Priority :** Medium **Asset Tag :**  
**Originated Date :** 02/10/2026 - Christine Weale - National TAB

Project Issue File Details

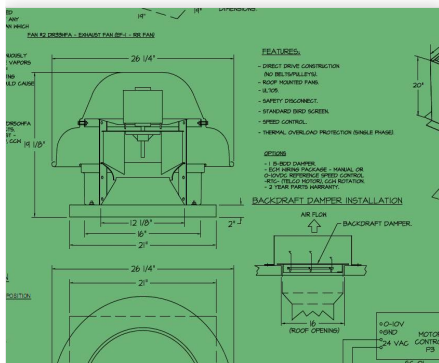

02/10/2026



02/10/2026



02/10/2026



02-02-26 QT #1403 PHOENIX, AZ

**Project Issue Information**

**Issue Name :** EF3 NOT PROPERLY INSTALLED  
**Description :** Hinge should be installed opposite of grease cup.  
**Created By :** National TAB                      **Assigned To :** National TAB - Dan Hertenstein  
**Status :** Open  
**Priority :** Low                                      **Asset Tag :** EF3  
**Originated Date :** 02/10/2026 - Christine Weale - National TAB

Project Issue File Details



02/10/2026

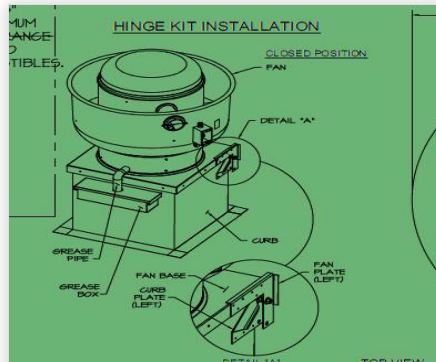

02/10/2026



02-02-26 QT #1403 PHOENIX, AZ

**Project Issue Information**

**Issue Name :** INACCESSIBLE DAMPER  
**Description :** Duct is not routed per GRD, it goes somewhere into the kitchen, therefore the damper is inaccessible (no tiles to remove).  
**Created By :** National TAB                      **Assigned To :** National TAB - Dan Hertenstein  
**Status :** Open  
**Priority :** Low                                      **Asset Tag :** SGRD5  
**Originated Date :** 02/10/2026 - Christine Weale - National TAB

Project Issue File Details



02/10/2026

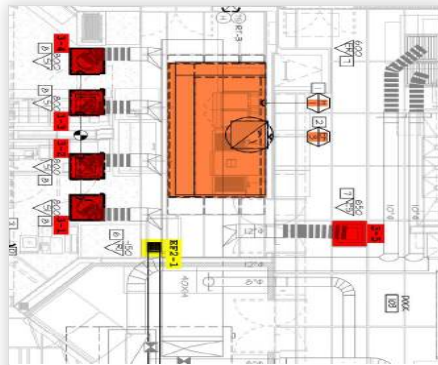

02/10/2026



**02-02-26 QT #1403 PHOENIX, AZ**

**Project Issue Information**

**Issue Name :** KINKED/RESTRICTED DUCT  
**Description :** SGRD1-13 Flow varies between -40 and 40cfm; which means low flow is due to restricted duct (lots of turbulence). Picture shows either wires or duct placed to the wrong side. Duct should be moved to the right of the wires to avoid kinks. High priority due to how hot it is in the electrical room.  
**Created By :** National TAB                      **Assigned To :** National TAB - Dan Hertenstein  
**Status :** Open  
**Priority :** High                                      **Asset Tag :** SGRD13  
**Originated Date :** 02/03/2026 - Christine Weale - National TAB

Project Issue File Details

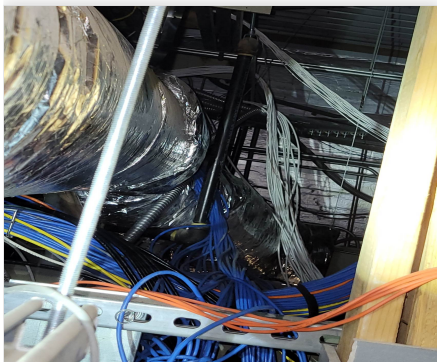

02/10/2026

### AIR BALANCE SCHEDULE

UNIT	AREA SERVED	HOOD ON OA		HOOD OFF OA		HOOD ON EXHAUST		HOOD OFF EXHAUST	
		DESIGN	ACTUAL	DESIGN	ACTUAL	DESIGN	ACTUAL	DESIGN	ACTUAL
RTU 1	SALES	800	873	350	351				
RTU-2	SALES	800	818	350	378				
RTU-3	BOH/KITCHEN	800	832	350	364				
EF-1	WOMEN'S RR					225	211	225	211
EF-2	MEN'S RR					525	526	525	526
EF-3	HOOD					1350	1383	0	0
<b>TOTALS</b>		<b>2400</b>	<b>2523</b>	<b>1050</b>	<b>1093</b>	<b>2100</b>	<b>2120</b>	<b>750</b>	<b>737</b>

#### HOOD ON

##### NET AIRFLOW CALCULATION

TOTALS	DESIGN	ACTUAL
TOTAL OA	2400	2523
TOTAL EXHAUST	2100	2120
<b>NET AIRFLOW</b>	<b>300</b>	<b>403</b>

DOOR TESTED	BUILDING PRESSURE MEASUREMENTS
FRONT	0.003
SIDE	0.003
REAR	0.003
<b>AVERAGE</b>	<b>0.003</b>

#### HOOD OFF

##### NET AIRFLOW CALCULATION

TOTALS	DESIGN	ACTUAL
TOTAL OA	1050	1093
TOTAL EXHAUST	750	737
<b>NET AIRFLOW</b>	<b>300</b>	<b>356</b>

DOOR TESTED	BUILDING PRESSURE MEASUREMENTS
FRONT	0.003
SIDE	0.004
REAR	0.002
<b>AVERAGE</b>	<b>0.003</b>

NOTES:

## CheckList List

- 01: RTU's/AHU's
- 02: Exhaust Fans
- 03: Hoods
- 04: Final Tests
- 05: Smoke Detector



02-02-26 QT #1403 PHOENIX, AZ

CheckList Information

**Name :** 01: RTU's/AHU's **Status :** Completed

**Assigned Organization :** National TAB **Asset :**

**Requesting Organization :** National TAB

**Created Date :** 01/05/2026 - Trinity Dodds - National TAB

**Completed Date :** 02/10/2026 - Christine Weale - National TAB

CheckList Item Details

RTU's/AHU's

Evaporator coils are clean?	Pass
Comment:	
Condenser coils are clean?	Pass
Comment:	
Gas piping is installed and valves are turned on?	Pass
Comment:	
Unit free of noticeable noise and vibration	Pass
Comment:	



**02-02-26 QT #1403 PHOENIX, AZ**

**CheckList Information**

**Name :** 02: Exhaust Fans **Status :** Completed  
**Assigned Organization :** National TAB **Asset :**  
**Requesting Organization :** National TAB  
**Created Date :** 01/05/2026 - Trinity Dodds - National TAB  
**Completed Date :** 02/10/2026 - Christine Weale - National TAB

**CheckList Item Details**

EF's

---

Hinge kit installed installed on hood fan? Pass

Comment:

---

Flex conduit is long enough so that fan can be completely tilted back? Pass

Comment:

---

No major leakage around the fan base Pass

Comment:

---

Unit is free of noise and vibration Pass

Comment:



02-02-26 QT #1403 PHOENIX, AZ

CheckList Information

**Name :** 03: Hoods **Status :** Completed

**Assigned Organization :** National TAB **Asset :**

**Requesting Organization :** National TAB

**Created Date :** 01/05/2026 - Trinity Dodds - National TAB

**Completed Date :** 02/10/2026 - Christine Weale - National TAB

CheckList Item Details

HOODS

Hood is free of alarms? Pass

Comment:

Hood is free of damage? Pass

Comment:

End panels are installed per prototype? Pass

Comment:



02-02-26 QT #1403 PHOENIX, AZ

CheckList Information

**Name :** 04: Final Tests **Status :** Completed

**Assigned Organization :** National TAB **Asset :**

**Requesting Organization :** National TAB

**Created Date :** 01/05/2026 - Trinity Dodds - National TAB

**Completed Date :** 02/10/2026 - Christine Weale - National TAB

CheckList Item Details

FINAL CHECKS

HOOD CAPTURE TEST

List kitchen equipment turned on for testing

Comment:

N/A

List smoke candle type used

Comment:

45s S102

Smoke test capture % - Perimeter of hood

Comment:

100

Smoke test capture % - Top of cooking surface

Comment:

100 (as long as fan for dual-oven is off)

WITNESS

Date test was completed

02/03/2026

**Comment:**

---

**TAB tech name / Firm**

---

**Comment:**

Christine Weale, NTI

---

**Site super name / Firm**

---

**Comment:**

T-Built

---

**Owner representative name / Firm (if Applicable)**

---

**Comment:**

---

**BUILDING PRESSURE**

---

**Do actual net building airflow, design net building airflow, and pressure coincide? If not why? (All three should either be positive or negative)**

---

**Comment:**

---



02-02-26 QT #1403 PHOENIX, AZ

CheckList Information

**Name :** 05: Smoke Detector **Status :** Completed

**Assigned Organization :** National TAB **Asset :**

**Requesting Organization :** National TAB

**Created Date :** 02/03/2026 - Trinity Dodds - National TAB

**Completed Date :** 02/04/2026 - Christine Weale - National TAB

CheckList Item Details

**Smoke Detector Manufacturer:**

**Comment:**

System Sensor

**Smoke Detector Model:**

**Comment:**

AD4S

**Accpetable Pressure Range Rating:**

**Comment:**

0.01-1.11"

**Actual Measured Pressure Range:**

**Comment:**

Unit1: 0.02" & 0.01", Unit2: 0.04" & 0.025", Unit3: 0.06" & 0.09"

**Smoke Detector Shutdown?**

Fail

**Comment:**

Unit1: Snsr1 (duct) failed, Unit2: Snsr2 (duct) failed, Unit3: Snsr1 (duct) failed.

**Notes/Comments :**

Unit1 and Unit3 duct detectors show 'Maintenance Required', Unit2 duct sensor displays code for 'Trouble'.





# National TAB

Project: 02-02-26 QT #1403 PHOENIX, AZ

System/Unit: AHU/RTU

Asset: RT-1

AREA:SALES FLOOR

Unit Data	
	Actual
MFG	AAON
Serial Num	201712-ANEL16666
Model Num	RN-015-8-0-EA0A-152
Num OA Filters 1	1
OA Filter Size 1	45X22
Num Final Filter 1	2
Final Filter Size 1	46X19.5X2

Motor Data	
	Actual
Motor MFG	NL
Frame	NL
Horsepower	5.0
Motor Rpm	1760
Phase	3
Rated Voltage	208
Rated Amperage	16.7

Test Data		
	Design	Actual
SF CFM	4200	4128
SF RPM	-	30 HZ
OA CFM (Hoods On)	800	873
OA CFM (Hoods Off)	350	351
RL Voltage	-	54.9
RL Amperage	-	7.81
VFD Max SetPt	-	50.0
VFD Min SetPt	-	24.0
OA Damper Position (Hoods On)	-	48.0
OA Damper Position (Hoods Off)	-	10.0

Performance Data		
	Design	Actual
MA Plenum SP	-	-0.27"
Fan Suction SP	-	-0.38"
Fan Discharge SP	-	0.32"
Total ESP	-	0.59"
Fan Total SP	-	0.70"

General	
	Actual
Fan Rotation Correct	YES
Unit Filters Clean	YES
Condensate Drain Installed	YES

Completed By: Christine Weale on 02/10/2026

**General - PHOTO LOG**



**02/10/2026**



# National TAB

Project: 02-02-26 QT #1403 PHOENIX, AZ

System/Unit: AHU/RTU

Asset: RT-2

AREA:SALES FLOOR

Unit Data	
	Actual
MFG	AAON
Serial Num	201712-ANEL16665
Model Num	RN-015-8-0-EA0A-152
Num OA Filters 1	1
OA Filter Size 1	45X22
Num Final Filter 1	2
Final Filter Size 1	46X19.5X2

Motor Data	
	Actual
Motor MFG	NL
Frame	NL
Horsepower	5.0
Motor Rpm	1760
Phase	3
Rated Voltage	208
Rated Amperage	16.7

Test Data		
	Design	Actual
SF CFM	4200	4062
SF RPM	-	30 HZ
OA CFM (Hoods On)	800	818
OA CFM (Hoods Off)	350	378
RL Voltage	-	54.6
RL Amperage	-	7.53
VFD Max SetPt	-	50.0
VFD Min SetPt	-	24.0
OA Damper Position (Hoods On)	-	30
OA Damper Position (Hoods Off)	-	10

Performance Data		
	Design	Actual
MA Plenum SP	-	-0.29"
Fan Suction SP	-	-0.39"
Fan Discharge SP	-	0.25"
Total ESP	-	0.54"
Fan Total SP	-	0.64"

General	
	Actual
Fan Rotation Correct	YES
Unit Filters Clean	YES
Condensate Drain Installed	YES

Completed By: Christine Weale on 02/10/2026



# National TAB

Project: 02-02-26 QT #1403 PHOENIX, AZ

System/Unit: AHU/RTU

Asset: RT-3

AREA:BOH/KITCHEN

Unit Data	
	Actual
MFG	AAON
Serial Num	201712-ANEK16667
Model Num	RN-013-8-0-EA0A-142
Num OA Filters 1	1
OA Filter Size 1	45X22
Num Final Filter 1	2
Final Filter Size 1	46X19.5X2

Motor Data	
	Actual
Motor MFG	NL
Frame	NL
Horsepower	3.0
Motor Rpm	1760
Phase	3
Rated Voltage	208
Rated Amperage	10.6

Test Data		
	Design	Actual
SF CFM	4200	4474
SF RPM	-	43.5 HZ
OA CFM (Hoods On)	800	832
OA CFM (Hoods Off)	350	364
RL Voltage	-	145.7
RL Amperage	-	9.69
VFD Max SetPt	-	72.5
VFD Min SetPt	-	24.0
OA Damper Position (Hoods On)	-	30
OA Damper Position (Hoods Off)	-	10

Performance Data		
	Design	Actual
MA Plenum SP	-	-0.59"
Fan Suction SP	-	-0.93"
Fan Discharge SP	-	0.75"
Total ESP	-	1.34"
Fan Total SP	-	1.68"

General	
	Actual
Fan Rotation Correct	YES
Unit Filters Clean	YES
Condensate Drain Installed	YES

Completed By: Christine Weale on 02/10/2026



# National TAB

Project:02-02-26 QT #1403 PHOENIX, AZ

## AHU/RTU

**Diffuser Supply (GRD)**

**RT-3/BOH/KITCHEN**

Asset									
Asset Name	Location	Type	Size	DESIGN CFM	AK	CFM(1)	CFM(2)	FINAL CFM	% to design
SGRD1	SUPPORT SERVICE	SI	12"	800	1	1007	673	845	105.6
SGRD2	SUPPORT SERVICE	SI	12"	800	1	1048	583	756	94.5
SGRD3	SUPPORT SERVICE	SI	12"	800	1	895	612	779	97.4
SGRD4	SUPPORT SERVICE	SI	12"	800	1	715	617	775	96.9
SGRD5	DOCK	ES	12"	650	1	1127	865	1078	165.8
SGRD6	WORKROOM	ES	8"	350	1	244	210	241	68.9
Total				4200		5036	3560	4474	106.52%

Asset	Notes	Date	Written By
SGRD5	DAMPER INACCESSIBLE, SEE 'REMARKS'.	02/10/2026	Christine Weale



# National TAB

Project: 02-02-26 QT #1403 PHOENIX, AZ

## System/Unit: FAN - Exhaust

Asset: EF1

AREA:WOMEN'S RR

Unit Data		
	Design	Actual
MFG	NA	CAPTIVEAIRE
Model Num	NA	DR12HFA
Serial Num	-	3235554
Type	-	DOWNBLAST
Configuration	-	VERTICAL

Motor Data		
	Design	Actual
Motor MFG	-	HSSA
Frame	-	48Y
Horsepower	-	0.167
Motor Rpm	-	1625
Phase	-	1
Voltage (rated)	-	115
Amperage (rated)	-	1.9
Service Factor	-	1.0

Test Data		
	Design	Actual
CFM	225	211
Fan RPM	-	N/A
Fan Rotation	-	CCW
Motor RPM	-	N/A
System SetPt	-	MED-LOW@SPD CTRLR
RL Voltage	-	70.8
RL Amperage	-	1.82
Total ESP	-	0.03"
Fan Inlet SP	-	-0.03"
Fan Discharge SP	-	ATMS

Completed By: Christine Weale on 02/10/2026

Unit Data - PHOTO LOG



02/10/2026



02/10/2026



# National TAB

Project: 02-02-26 QT #1403 PHOENIX, AZ

## System/Unit: FAN - Exhaust

Asset: EF2

AREA: MEN'S RR/COMBI

Unit Data		
	Design	Actual
MFG	NA	CAPTIVEAIRE
Model Num	NA	DR30HFA
Serial Num	-	3235554
Type	-	DOWNBLAST
Configuration	-	VERTICAL

Motor Data		
	Design	Actual
Motor MFG	-	HSSA
Frame	-	48Y
Horsepower	-	0.25\0.33
Motor Rpm	-	1625
Phase	-	1
Voltage (rated)	-	115
Amperage (rated)	-	3.0\3.8
Service Factor	-	1.0

Test Data		
	Design	Actual
CFM	375	364
Fan RPM	-	N/A
Fan Rotation	-	CCW
Motor RPM	-	N/A
System SetPt	-	LOW@SPD CTRLR
RL Voltage	-	57.8
RL Amperage	-	3.4
Total ESP	-	0.11"
Fan Inlet SP	-	-0.11"
Fan Discharge SP	-	ATMS

Completed By: Christine Weale on 02/10/2026



# National TAB

Project: 02-02-26 QT #1403 PHOENIX, AZ

System/Unit: FAN - Exhaust

Asset: EF4

AREA:COMBI-OVEN

Unit Data	
	Actual
MFG	N/A
Model Num	N/A
Serial Num	N/A

Test Data		
	Design	Actual
CFM	150	172
RL Voltage	-	N/A
RL Amperage	-	N/A

Motor Data		
	Design	Actual
Motor MFG	-	N/A
Horsepower	-	N/A
Motor Rpm	-	N/A
Phase	-	N/A
Voltage (rated)	-	N/A
Amperage (rated)	-	N/A

Completed By: Christine Weale on 02/10/2026

Notes:  
REQUESTED INFO NOT GIVEN, MOTOR INACCESSIBLE.

Written By: Christine Weale on 02/10/2026

**Unit Data - PHOTO LOG**



**02/10/2026**



**02/10/2026**



# National TAB

Project: 02-02-26 QT #1403 PHOENIX, AZ

## System/Unit: FAN - Exhaust

Asset: EF3

AREA:KITCHEN HD

Unit Data		
	Design	Actual
MFG	NA	CAPTIVEAIRE
Model Num	NA	DU50HFA
Serial Num	-	8257626
Type	UPBLAST	UPBLAST
Configuration	VERTICAL	VERTICAL

Motor Data		
	Design	Actual
Motor MFG	-	NEMA
Frame	-	48
Horsepower	0.50	0.5
Motor Rpm	-	1800
Phase	1	1
Voltage (rated)	208	208
Amperage (rated)	-	3.8
Service Factor	-	NL

Test Data		
	Design	Actual
CFM	1350	1383
Fan RPM	-	1250
Fan Rotation	-	CCW
Motor RPM	-	1250
System SetPt	-	55.8HZ - 69%
RL Voltage	-	216.0
RL Amperage	-	2.05
Total ESP	0.75"	0.75"
Fan Inlet SP	-	-0.75"
Fan Discharge SP	-	ATMS

Completed By: Christine Weale on 02/10/2026

**Unit Data - PHOTO LOG**



02/10/2026



02/10/2026



# National TAB

Project: 02-02-26 QT #1403 PHOENIX, AZ

## System/Unit: Kitchen Hood Type I

Asset: HD1

AREA:GRIDDLE

### Unit Data

	Design	Actual
MFG	CAPTIVEAIRE	CAPTIVEAIRE
Model Num	6030ND-2-F	6030ND-2-F
Job / Serial Num	-	8257626
Type	TYPE I CANOPY	TYPE I CANOPY
Hood length	108"	108"
Hood Width	60"	60"

### Test Data Exhaust

	Design	Actual
Filter Type	CAPTRATE SOLO FILTER	CAPTRATE SOLO
Filter Size 1	20X16	16X20
Filter Qty 1	6	6
Filter AK factor size 1	2.08	2.08
Filter Total AK Area	12.48	12.48
Filter1 FPM	-	108
Filter2 FPM	-	112
Filter3 FPM	-	116
Filter4 FPM	-	108
Filter5 FPM	-	113
Filter6 FPM	-	108
Filter Ave FPM(corr)	-	110.8
CFM	1350	1383

### Cooking Equipment

	Actual
Item 1	FRYERS
Item 2	DUAL-OVEN

Completed By: Christine Weale on 02/10/2026

