

Submittal

Project: ELON HAWK RIDGE POLO RELIEF ES

View Date: 07/26/2022

Submittal No. / Revision: 237412-1 1 Subcontractor/Supplier: Superior Mechanical Systems (Charlotte)	Description: Single Zone Packaged Rooftop Units - Product Data
Submittal Type: Product Data Spec. Section & Paragraph No.: 237412	Required on site by: Required lead time: Status: Submitted to AE
Notes: A. Product Data: Include manufacturer's technical data for each RTU, including rated capacities, dimensions, required clearances, characteristics, furnished specialties, and accessories.	

Superior Mechanical Systems (Charlotte)	Balfour Beatty Construction, LLC Stamp
Submittal No. / Revision: 237412-1 1 Description: Single Zone Packaged Rooftop Units - Product Data Subcontractor certifies that review, approval, verification of products required, field dimensions, adjacent construction work, and coordination of information is in accordance with the requirements of the work and contract documents. Submitted By: Ben Wyke Date:	<p style="color: green;">This submittal has been reviewed for general compliance with the plans and specification. This review and the response indicated below does not relieve subcontractor/ supplier of any contractual responsibilities including the furnishing of all items required by the contract documents and the confirmation of all quantities and dimensions.</p> <p style="color: green;">Submittal No.: 237412-1 1 Description: Single Zone Packaged Rooftop Units - Product Data Reviewed by: Aidan Mulligan Date: 07/26/2022</p>

Little Diversified Architectural Consul (Charlotte) Stamp	Consultant Stamp
A/E Response: Date:	<div style="border: 1px solid red; padding: 10px;"> <p style="text-align: center;">SHOP DRAWING REVIEW</p> <div style="display: flex; justify-content: space-between; align-items: center;"> <div style="width: 60%;"> <p><input type="checkbox"/> NO EXCEPTION TAKEN</p> <p><input checked="" type="checkbox"/> APPROVED AS NOTED</p> <p><input type="checkbox"/> REVISE AND RESUBMIT</p> <p><input type="checkbox"/> REJECTED</p> </div> <div style="width: 30%; text-align: center;">  </div> </div> <p style="color: red; font-size: small; text-align: right;">See submittal for comments</p> <p style="font-size: x-small; text-align: center;">REVIEW IS FOR GENERAL COMPLIANCE WITH THE INTENT OF THE CONTRACT DOCUMENTS. MECHANICAL CONTRACTOR SHALL ASSUME RESPONSIBILITY FOR CORRECTNESS, DIMENSIONS, DETAILS, QUANTITIES AND ALL COST ASSOCIATED WITH SUBSTITUTED EQUIPMENT, INCLUDING STRUCTURAL AND ELECTRICAL CHANGES, MAINTENANCE ACCESS, CLEARANCES, BUILDING ALTERATIONS, PIPING, SHEET METAL, REPLACEMENT OF OTHER SYSTEM COMPONENTS, ETC.</p> <p style="font-size: x-small; display: flex; justify-content: space-between;"> BY T Hogue DATE 7/28/2022 </p> </div>

Consultant Stamp	

From: Giel, Taylor <Taylor.E.Giel@Carrier.com>
Sent: Tuesday, July 26, 2022 2:42 PM
To: Mulligan, Aidan; Ben Wyke
Cc: Parks, Michael; Ramirez, Yuliza; Mitch Thomas
Subject: RE: [External]RE: CMS EHPR Furnished as Corrected
Attachments: [Commercial DOE Updates.pdf](#)

Aiden,

Thank you for the quick response on this. The reasoning behind the delay with the RTUs is as follows. The DOE standards for 2023 are changing and require higher IEER efficiency on rooftop units. Carrier knew this and years ago started Research and Development on new units to meet these 2023 requirements. These units were originally scheduled to be released for sale in late Q3 of 2022 that would match a normal world's lead times to line up with 2023 shipment and the ceasing of production of the old 48HC units. The issue that took place was that the 48HC units that originally were proposed on this job had their lead times unexpectedly shoot out extremely far due to component shortages and supply chain issues. This meant that Carrier had to immediately cease taking all orders in mid-May 2022 on the old 48HC equipment as they could no longer guarantee that they would ship before the end of 2022 to meet the requirement on January 1st 2023 for higher efficiency equipment. This unfortunately did not come with a warning as the current world's lead times are unprecedented and could not be foreseen. The new 48FC units that meet the new 2023 DOE requirements could only get sped up so much in their release as they required going through independent third party testing to validate the new rooftops published efficiencies and capacities. This caused a gap in Carrier's offering for equipment in the 15-27.5 tonnage range of RTUs. Now that the new 48FC units have passed 3rd party testing and meet the 2023 DOE requirements they are available for sale. I have tried my best to resubmit on them as quickly as possible as the new equipment has just recently been released in the past couple of days.

I apologize for the confusion on this as I know this is not ideal. I have attached a flyer on the 2023 DOE requirements to show the changes in efficiency. Page 5 shows the rooftop unit changes from the old standards to the new 2023 standards for your reference. Please let me know if you have any questions regarding any of this.

Thanks,

Taylor Giel | Sales Engineer | Carrier Commercial Systems | Carrier Corporation
Direct: 704.534.9485 | taylor.e.giel@carrier.com | corporate.carrier.com



*Need a service call? Call Carrier Service at **800-379-6484***

*Need a rental system? Call Carrier Rentals at **704-792-1330***



SUBMITTAL

Project

CMS Elon, Hawk, Polo Ridge

Date

Tuesday, July 26, 2022

Mechanical Engineer

Optima Engineering

Mechanical Contractor

Superior Mechanical Systems Inc.

In accordance with Specification SECTION 237412
SINGLE ZONE PACKAGED ROOFTOP UNITS

Notes:

1. Rooftop Unit Curb Provided by Others
2. **MERV 10 Filters to be field installed**
3. **Drain Pan is a sloped condensate drain pan made of a composite non-corrosive material and shall comply with ASHRAE Standard 62.**

Schedule calls for stainless
steel drain pan

Table Of Contents

Project: CMS Elon, Hawk, Polo Ridge
Prepared By: Paul Shelor

07/26/2022
12:19PM

RTU-1 48FC	3
Unit Report.....	4
Certified Drawing.....	5
Performance Summary.....	10
Guide Specifications.....	13

RTU-1, 48FC

**Tag Cover Sheet
Unit Report
Certified Drawing
Performance Report
Guide Specification**

Unit Report For **RTU-1, 48FC**

Project: CMS Elon, Hawk, Polo Ridge
 Prepared By: Paul Shelor

07/26/2022
 12:19PM

Unit Parameters

Unit Model:.....**48FCTN20J2M6-3W5C0**
 Unit Size:.....**20 (17.5 Tons)**
 Volts-Phase-Hertz:.....**460-3-60**
 Heating Type:.....**Gas**
 Duct Cfg:.....**Vertical Supply / Vertical Return**
 Stainless Steel, High Heat
 Two Stage Cooling/Single Circuit with Humidi-MiZer

Dimensions (ft. in.) & Weight (lb.) ***

Unit Length:.....**10' 7.875"**
 Unit Width:.....**7' 2.375"**
 Unit Height:.....**3' 11.75"**

*** Weights and Dimensions are approximate. Weight does not include roof curbs, unit packaging, field installed accessories or factory installed options. Approximate dimensions are provided primarily for shipping purposes. For exact dimensions and weights, refer to appropriate product data catalog.

Base Unit Weight (Does not include any accessories):

1800.....lb

Lines and Filters

Gas Line Size:.....**3/4**
 Condensate Drain Line Size:.....**3/4**
 Return Air Filter Type:.....**Throwaway**
 Return Air Filter Quantity:.....**6**
 Return Air Filter Size:.....**20 x 25 x 2**

Selection includes construction throwaway filter into the base fan curve. This filter is not MERV Rated.

Unit Configuration

Condensate Overflow Switch
 Std/Medium Static Option - Vertical Models
 Al/Cu - Al/Cu - Louvered Hail Guard
 SystemVu Controller
 Enthalpy Ultra Low Leak Econo w/Baro Relief, Vertical and Horizontal airflow
 Hinged Access Panels and Powered Convenience Outlet
 Non-Fused Disconnect
 Standard Packaging
 Humidi-MiZer™ Adaptive Dehumidification System

Warranty Information

1-Year parts(std.)
 5-Year compressor parts(std.)
 15-Year heat exchanger - Stainless Steel(std.)
 3-Year SystemVu Controller
 Start-up, First Unit
 Complete Unit 1st Year Carrier CCS Labor
 Complete Unit Year 2-3 Parts Only

Cover letter notes MERV 10 filtration provided.

NOTE: Please see Warranty Catalog 500-089 for explanation of policies and ordering methods.

Ordering Information

Part Number	Description	Quantity
48FCTN20J2M6-3W5C0	Rooftop Unit	1
	Base Unit	
	Condensate Overflow Switch	
	Al/Cu - Al/Cu - Louvered Hail Guard	
	Hinged Access Panels and Powered Convenience Outlet	
	Non-Fused Disconnect	
	Humidi-MiZer™ Adaptive Dehumidification System	
	SystemVu controller, ULTRA LOW LEAK EconoMiSer2 enthalpy economizer with barometric relief. SystemV	
Field Installed Accessories		
20X25X2-M8-R-P6	20x25x2 MERV-8 replacement air filters	1
ZS2-BNK	ZS Standard	1

Certified Drawing for RTU-1, 48FC

Project: CMS Elon, Hawk, Polo Ridge
Prepared By: Paul Shelor

07/26/2022
12:19PM

Carrier THIS DOCUMENT IS THE PROPERTY OF CARRIER CORPORATION AND IS DELIVERED UPON THE EXPRESS CONDITION THAT THE CONTENTS WILL NOT BE DISCLOSED OR USED WITHOUT CARRIER CORPORATION'S WRITTEN CONSENT. SUBMISSION OF THESE DRAWINGS OR DOCUMENTS DOES NOT CONSTITUTE PART PERFORMANCE OR ACCEPTANCE OF CONTRACT.

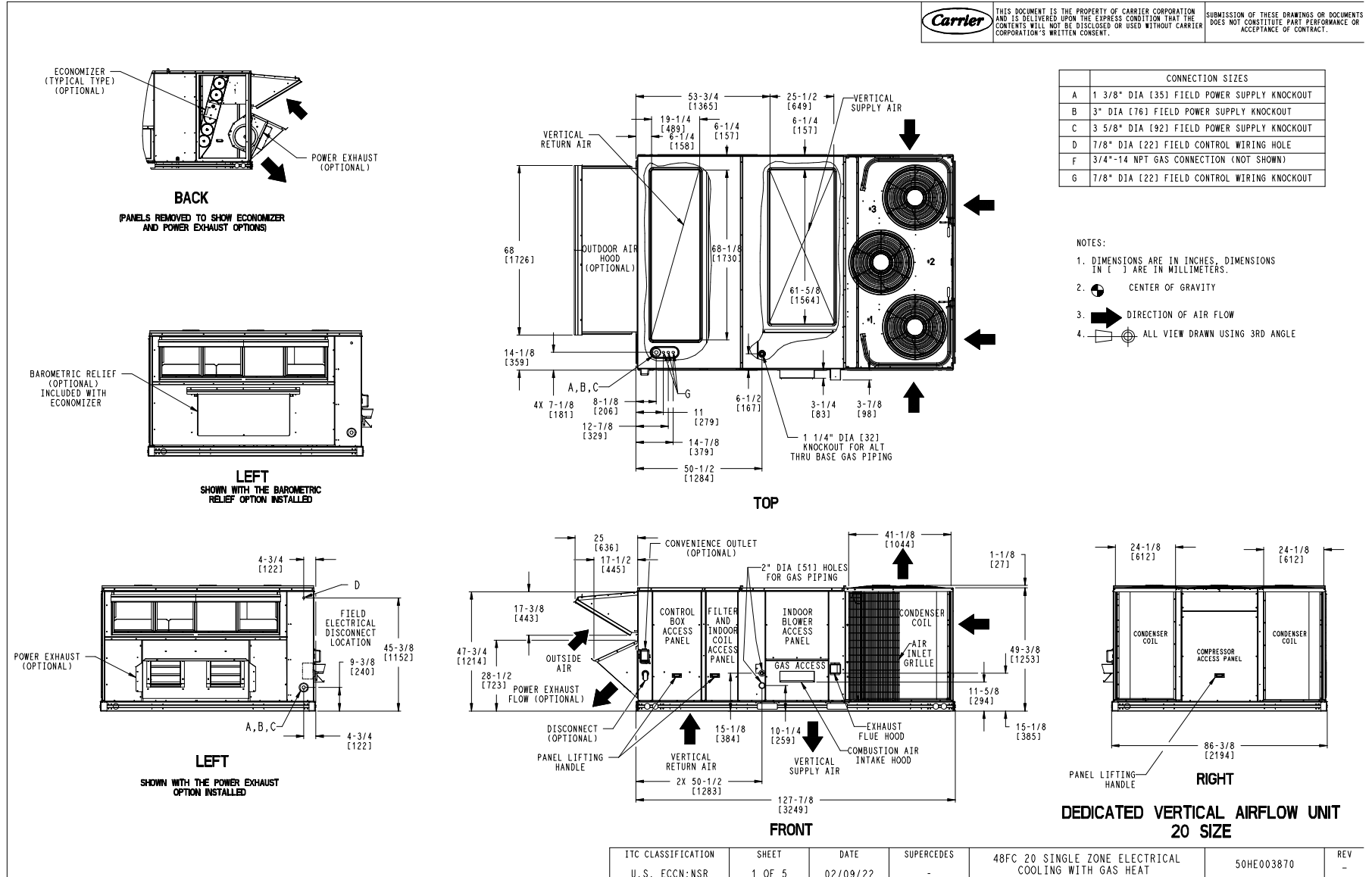

ITC CLASSIFICATION	SHEET	DATE	SUPERCEDES	48FC 20 SINGLE ZONE ELECTRICAL COOLING WITH GAS HEAT	50HE003870	REV
U.S. ECCN:NSR	1 OF 5	02/09/22	-			-

Certified Drawing for RTU-1, 48FC

Project: CMS Elon, Hawk, Polo Ridge
Prepared By: Paul Shelor

07/26/2022
12:19PM

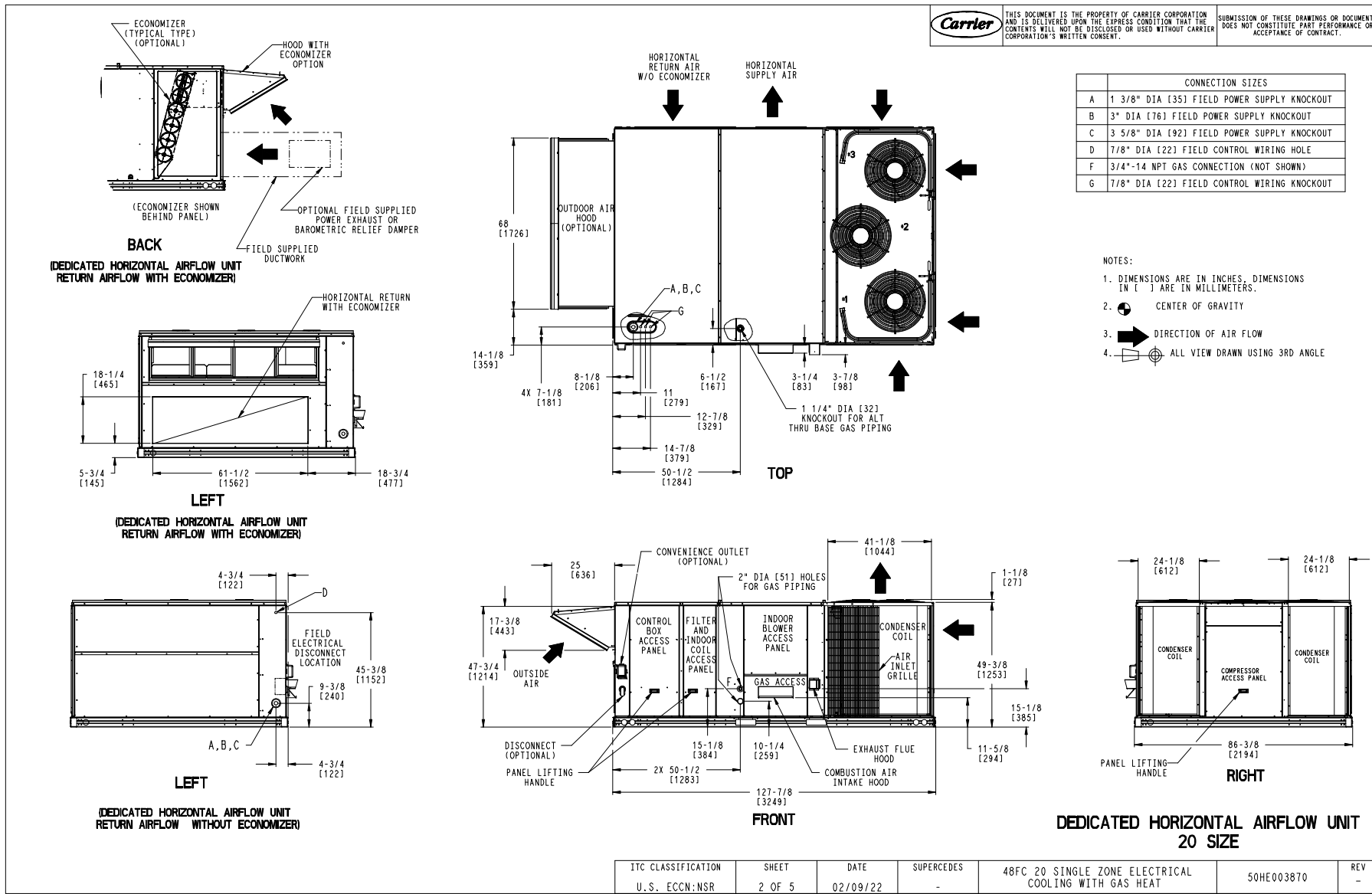

ITC CLASSIFICATION	SHEET	DATE	SUPERCEDES	48FC 20 SINGLE ZONE ELECTRICAL	50HE003870	REV
U.S. ECCN:NSR	2 OF 5	02/09/22	-	COOLING WITH GAS HEAT		-

Certified Drawing for RTU-1, 48FC

Project: CMS Elon, Hawk, Polo Ridge
 Prepared By: Paul Shelor

07/26/2022
 12:19PM

CONNECTION SIZES	
E	3/4"-14 NPT CONDENSATE DRAIN

Carrier THIS DOCUMENT IS THE PROPERTY OF CARRIER CORPORATION AND IS DELIVERED UPON THE EXPRESS CONDITION THAT THE CONTENTS WILL NOT BE DISCLOSED OR USED WITHOUT CARRIER CORPORATION'S WRITTEN CONSENT. SUBMISSION OF THESE DRAWINGS OR DOCUMENTS DOES NOT CONSTITUTE PART PERFORMANCE OR ACCEPTANCE OF CONTRACT.

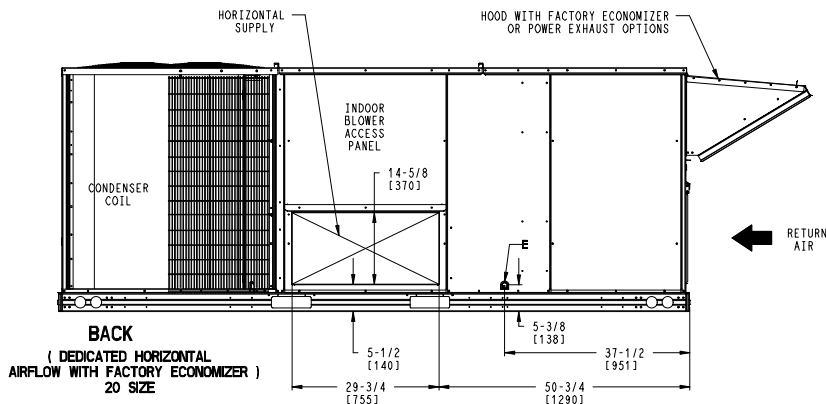
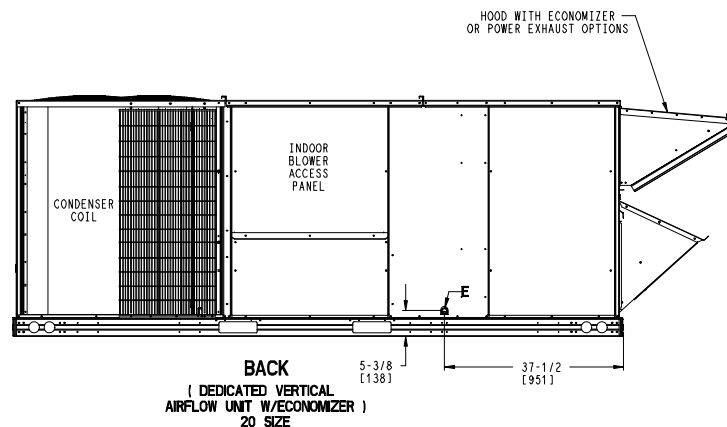
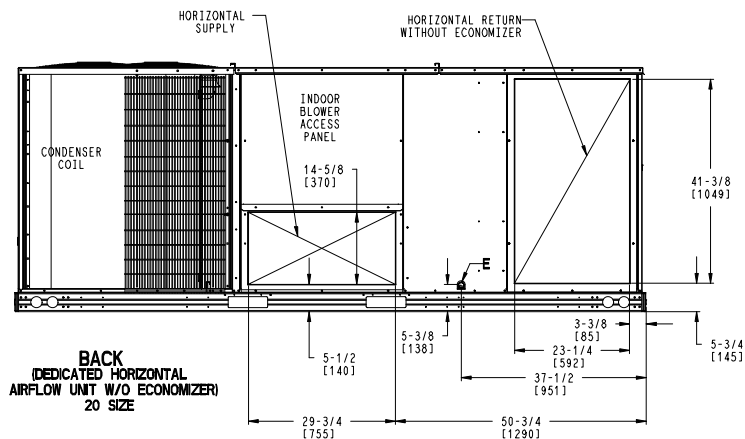

ITC CLASSIFICATION	SHEET	DATE	SUPERCEDES	48FC 20 SINGLE ZONE ELECTRICAL COOLING WITH GAS HEAT	50HE003870	REV
U.S. ECCN:NSR	3 OF 5	02/09/22	-			-

Certified Drawing for RTU-1, 48FC

Project: CMS Elon, Hawk, Polo Ridge
Prepared By: Paul Shelor

07/26/2022
12:19PM

UNIT	STD UNIT WEIGHT *		CORNER WEIGHT (A)		CORNER WEIGHT (B)		CORNER WEIGHT (C)		CORNER WEIGHT (D)		C.G.		
	LBS.	KG.	LBS.	KG.	LBS.	KG.	LBS.	KG.	LBS.	KG.	X	Y	Z
48FC20	1800	816	383	174	479	217	521	236	417	189	71 [1803]	45 [1143]	16 1/2 [419]

THIS DOCUMENT IS THE PROPERTY OF CARRIER CORPORATION AND IS DELIVERED UPON THE EXPRESS CONDITION THAT THE CONTENTS WILL NOT BE DISCLOSED OR USED WITHOUT CARRIER CORPORATION'S WRITTEN CONSENT. SUBMISSION OF THESE DRAWINGS OR DOCUMENTS DOES NOT CONSTITUTE PART PERFORMANCE OR ACCEPTANCE OF CONTRACT.

* STANDARD UNIT WEIGHT IS WITH LOW GAS HEAT AND WITHOUT PACKAGING. FOR OTHER OPTIONS AND ACCESSORIES, REFER TO THE PRODUCT DATA CATALOG.

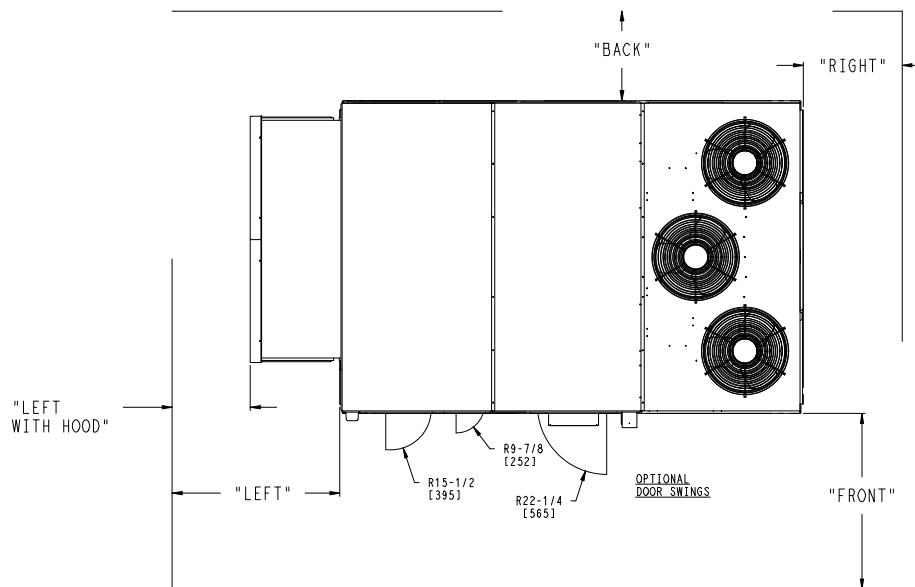
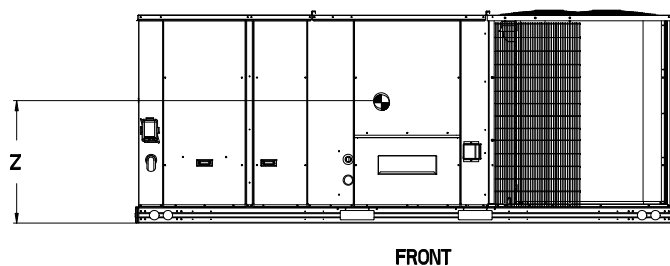
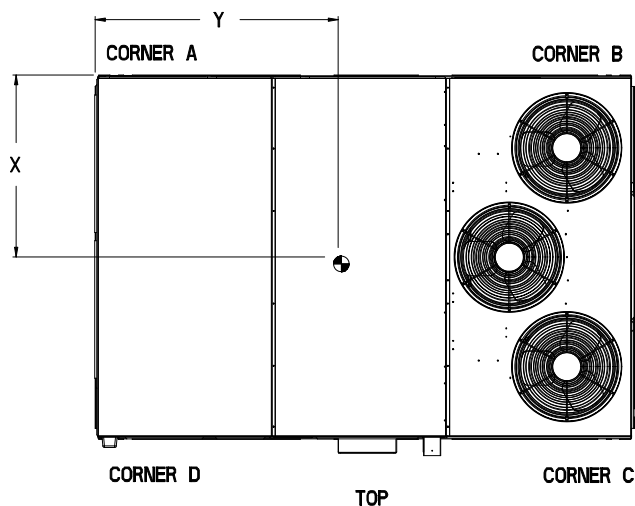

NOTES:

1. CLEARANCE ABOVE THE UNIT TO BE 72"
2. FOR ALL MINIMUM CLEARANCES LOCAL CODES OR JURISDICTIONS MAY PREVAIL.

SURFACE	CLEARANCE		OPERATING CLEARANCE
	SERVICE WITH CONDUCTIVE BARRIER	SERVICE WITH NONCONDUCTIVE BARRIER	
FRONT	48 [1219mm]	36 [914mm]	18 [457mm]
LEFT	48 [1219mm]	42 [1067mm]	18 [457mm]
BACK	42 [1067mm]	36 [914mm]	18 [457mm]
LEFT WITH HOOD	36 [914mm]	36 [914mm]	18 [457mm]
RIGHT	36 [914mm]	36 [914mm]	18 [457mm]
TOP	72 [1829mm]	72 [1829mm]	72 [1829mm]

ITC CLASSIFICATION U.S. ECCN: NSR	SHEET 4 OF 5	DATE 02/09/22	SUPERCEDES -	48FC 20 SINGLE ZONE ELECTRICAL COOLING WITH GAS HEAT	50HE003870	REV -
--------------------------------------	-----------------	------------------	-----------------	--	------------	----------

Certified Drawing for RTU-1, 48FC

Project: CMS Elon, Hawk, Polo Ridge
 Prepared By: Paul Shelor

07/26/2022
 12:19PM

	THIS DOCUMENT IS THE PROPERTY OF CARRIER CORPORATION AND IS DELIVERED UPON THE EXPRESS CONDITION THAT THE CONTENTS WILL NOT BE DISCLOSED OR USED WITHOUT CARRIER CORPORATION'S WRITTEN CONSENT.	SUBMISSION OF THESE DRAWINGS OR DOCUMENTS DOES NOT CONSTITUTE PART PERFORMANCE OR ACCEPTANCE OF CONTRACT.
---	---	---

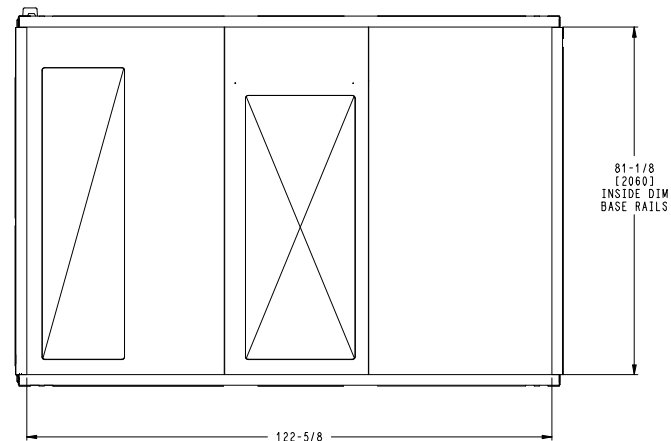
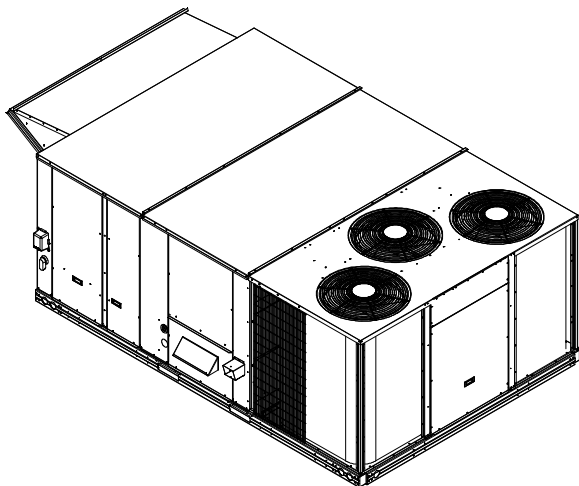

BOTTOM
INSIDE BASERAIL DIMENSIONS

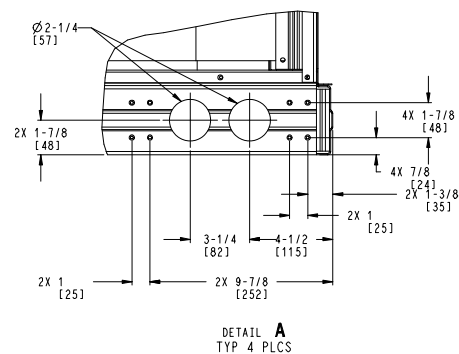
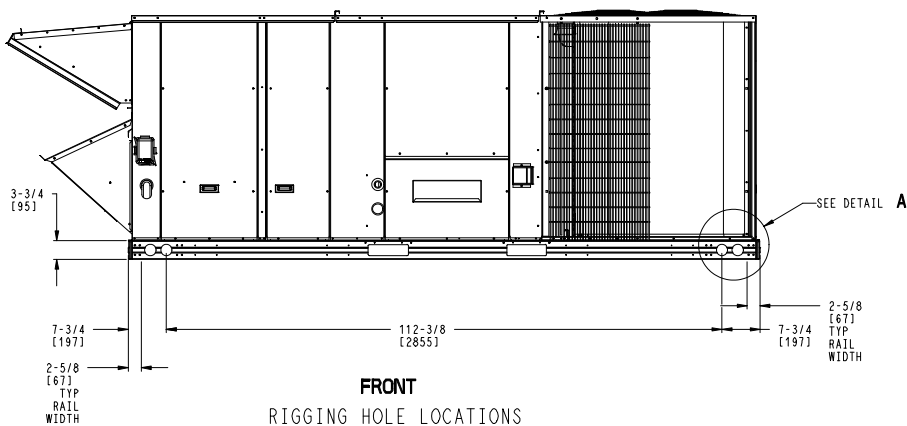

ITC CLASSIFICATION U.S. ECCN: NSR	SHEET 5 OF 5	DATE 02/09/22	SUPERCEDES -	48FC 20 SINGLE ZONE ELECTRICAL COOLING WITH GAS HEAT	50HE003870	REV -
--------------------------------------	-----------------	------------------	-----------------	---	------------	----------

Performance Summary For RTU-1, 48FC

Project: CMS Elon, Hawk, Polo Ridge
 Prepared By: Paul Shelor

07/26/2022
 12:19PM

Part Number: 48FCTN20J2M6-3W5C0

ARI EER: **10.80**
 IEER (Max Cooling at Normal Cooling Design Mode): **14.5**

Base Unit Dimensions

Unit Length: **127.9** in
 Unit Width: **86.4** in
 Unit Height: **47.8** in

Base Unit Weight (Does not include any accessories): **1800** lb

Unit

Unit Voltage-Phase-Hertz: **460-3-60**
 Air Discharge: **Vertical**
 Fan Drive Type: **Vane Axial**
 Actual Airflow: **6000** CFM
 Site Altitude: **0** ft

Cooling Performance

Condenser Entering Air DB: **95.0** F
 Evaporator Entering Air DB: **80.0** F
 Evaporator Entering Air WB: **67.0** F
 Entering Air Enthalpy: **31.44** BTU/lb
 Evaporator Leaving Air DB: **57.2** F
 Evaporator Leaving Air WB: **55.8** F
 Evaporator Leaving Air Enthalpy: **23.67** BTU/lb
 Gross Cooling Capacity: **209.66** MBH
 Gross Sensible Capacity: **147.66** MBH
 Compressor Power Input: **16.83** kW
 Coil Bypass Factor: **0.069**

Heating Performance

Heating Airflow: **6000** CFM
 Entering Air Temp: **70.0** F
 Leaving Air Temp: **120.0** F
 Gas Heating Input Capacity: **320.0 / 400.0** MBH
 Gas Heating Output Capacity: **260.0 / 324.0** MBH
 Temperature Rise: **50.0** F
 Thermal Efficiency (%): **81.0**

Coordinate input gas capacity with PC

Supply Fan

External Static Pressure: **1.00** in wg
 Options / Accessories Static Pressure
 Humidi-MiZer Dehumidification System: **0.07** in wg
 Economizer: **0.06** in wg
 MERV-8 Filter Kit: **0.10** in wg
 Total Application Static (ESP + Unit Opts/Acc.): **1.23** in wg
 Fan RPM: **1679**
 Fan Power: **3.56** BHP
 NOTE: **Selected IFM RPM Range: 250 - 1930**

Selection includes construction throwaway filter into the base fan curve. This filter is not MERV Rated.

Filter pressure drop assumes a clean filter and is intended to be an estimate based on available supplier data. The actual pressure drop the unit experiences may vary due to alternate suppliers or filter loading over time.

Electrical Data

Voltage Range: **414 - 506**
 Compressor #1 RLA: **14.7**
 Compressor #1 LRA: **130**

Performance Summary For RTU-1, 48FC

Project: CMS Elon, Hawk, Polo Ridge
 Prepared By: Paul Shelor

07/26/2022
 12:19PM

Compressor #2 RLA:.....	12.8
Compressor #2 LRA:.....	100
Indoor Fan Motor Type:.....	MED
Indoor Fan Motor FLA:.....	3
Combustion Fan Motor FLA (ea):.....	0.3
Power Supply MCA:.....	42.1
Power Supply MOCP (Fuse or HACR):.....	50
Disconnect Size FLA:.....	44
Disconnect Size LRA:.....	246
Electrical Convenience Outlet FLA (based on unit line voltage):.....	2.2
Outdoor Fan [Qty / FLA (ea)]:.....	3 / 0.9

NOTE: Convenience outlet must be field connected to the line/load side of the unit disconnect per local code.

Control Panel SCCR: 5kA RMS at Rated Symmetrical Voltage

Acoustics

Sound Power Levels, db re 10E-12 Watts

	Discharge	Inlet	Outdoor
63 Hz	90.5	89.8	92.2
125 Hz	85.1	76.3	83.9
250 Hz	77.1	70.7	80.4
500 Hz	75.9	63.2	81.8
1000 Hz	70.5	57.7	78.7
2000 Hz	68.9	52.4	76.5
4000 Hz	69.2	47.1	72.2
8000 Hz	59.8	36.7	65.4
A-Weighted	78.4	68.4	84.0

Advanced Acoustics

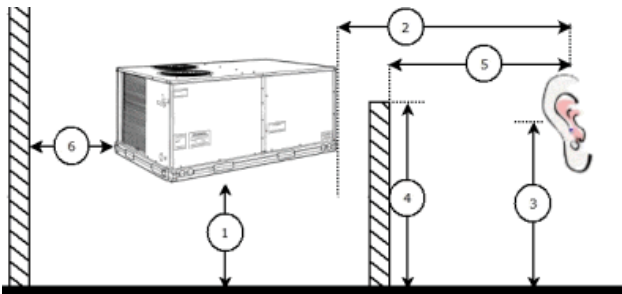

Advanced Acoustics Parameters

- 1. Unit height above ground:..... 30.0 ft
- 2. Horizontal distance from unit to receiver:..... 50.0 ft
- 3. Receiver height above ground:..... 5.7 ft
- 4. Height of obstruction:..... 0.0 ft
- 5. Horizontal distance from obstruction to receiver:..... 0.0 ft
- 6. Horizontal distance from unit to obstruction:..... 0.0 ft

Detailed Acoustics Information

Octave Band Center Freq. Hz	63	125	250	500	1k	2k	4k	8k	Overall
A	92.2	83.9	80.4	81.8	78.7	76.5	72.2	65.4	93.6 Lw
B	66.0	67.8	71.8	78.6	78.7	77.7	73.2	64.3	84.1 LwA

Performance Summary For RTU-1, 48FC

Project: CMS Elon, Hawk, Polo Ridge
 Prepared By: Paul Shelor

07/26/2022
 12:19PM

C	59.8	51.5	48.0	49.4	46.3	44.1	39.8	33.0	61.2 Lp
D	33.6	35.4	39.4	46.2	46.3	45.3	40.8	31.9	51.7 LpA

Legend

- A Sound Power Levels at Unit's Acoustic Center, Lw
- B A-Weighted Sound Power Levels at Unit's Acoustic Center, LwA
- C Sound Pressure Levels at Specific Distance from Unit, Lp
- D A-Weighted Sound Pressure Levels at Specific Distance from Unit, LpA

Calculation methods used in this program are patterned after the ASHRAE Guide; other ASHRAE Publications and the AHRI Acoustical Standards. While a very significant effort has been made to insure the technical accuracy of this program, it is assumed that the user is knowledgeable in the art of system sound estimation and is aware of the tolerances involved in real world acoustical estimation. This program makes certain assumptions as to the dominant sound sources and sound paths which may not always be appropriate to the real system being estimated. Because of this, no assurances can be offered that this software will always generate an accurate sound prediction from user supplied input data. If in doubt about the estimation of expected sound levels in a space, an Acoustical Engineer or a person with sound prediction expertise should be consulted.

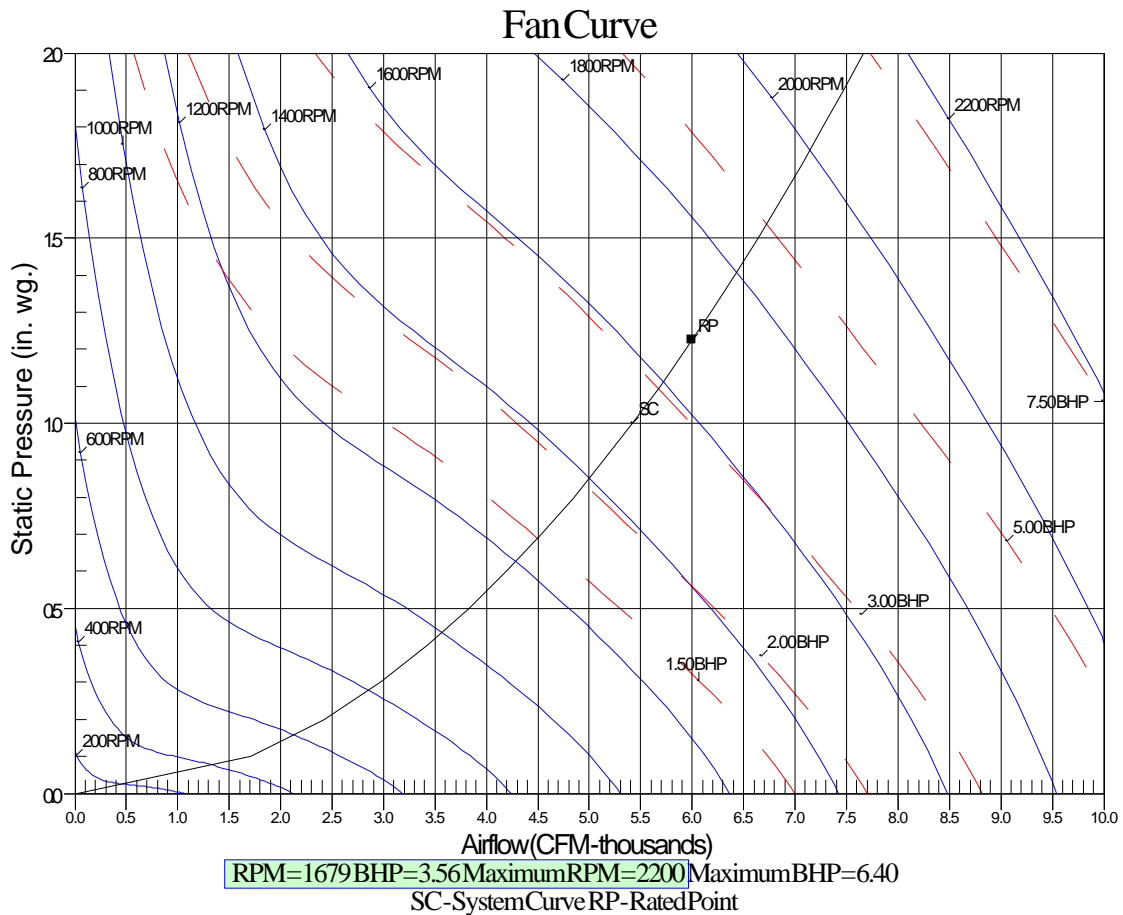

Guide Specification for RTU-1, 48FC

Project: CMS Elon, Hawk, Polo Ridge
Prepared By: Paul Shelor

07/26/2022
12:19PM

Guide Specification for RTU-1, 48FC

Project: CMS Elon, Hawk, Polo Ridge
Prepared By: Paul Shelor

07/26/2022
12:19PM

Note about this specification:

This specification is in the "Masterformat" as published by the Construction Specification Institute. Please feel free to copy this specification directly into your building spec.

Gas Heat/Electric Cooling Packaged Roof-top

HVAC Guide Specifications

Size Range: **17.5 to 27.5 Nominal Tons**

Carrier Model Number: **48FC*20-30**

(23 06 80) Schedules for Decentralized HVAC Equipment

(23 06 80.13) Decentralized Unitary HVAC Equipment Schedule

(23 06 80.13.A.) Rooftop unit (RTU) schedule:

1. Schedule is per the project specification requirements.

(23 07 16) HVAC equipment insulation

(23 07 16.13) Decentralized, Rooftop Units:

(23 07 16.13.A.) Evaporator fan compartment:

Provide foil faced insulation on interior of unit casing.

2. Interior cabinet surfaces shall be insulated with a minimum 1/2 in. thick, minimum 1 1/2 lb density, flexible fiberglass insulation bonded with a phenolic binder, neoprene coated on the air side.
2. Insulation and adhesive shall meet NFPA 90A requirements for flame spread and smoke generation.

(23 07 16.13.B.) Gas Heat Compartment:

3. Aluminum foil-faced fiberglass insulation shall be used.
3. Insulation and adhesive shall meet NFPA 90A requirements for flame spread and smoke generation.

(23 09 13) Instrumentation and control devices for HVAC

(23 09 13.23) Sensors and Transmitters

(23 09 13.23.A.) Thermostats

4. Thermostat must
 - a. energize both "W" and "G" when calling for heat.
 - b. have capability to energize 1 or 2 stages of cooling, and 2 different stages of heating.
 - c. include capability for occupancy scheduling.

(23 09 23) Direct Digital Control system for HVAC

(23 09 23.13) Decentralized, Rooftop Units:

(23 09 23.13.A.) SystemVu™ intelligent integrated Direct Digital Control (DDC) shall provide:

1. Integrated unit operation for comfort cooling, heating ventilation as well as all monitoring, recording and reporting capabilities. Controller shall also provide diagnostics and alarms of abnormal unit operation through the controller. Controller shall have an intuitive user display and be able to be used in a standalone operation or via building automation system (BAS).
2. Quick Unit Status LEDs of: RUN – meaning all systems are go, ALERT – that indicates there is currently a non-critical issue with the unit, like filters need to be replaced and FAULT – that indicates the unit has a critical issue and will possibly shutdown.

Guide Specification for RTU-1, 48FC

Project: CMS Elon, Hawk, Polo Ridge
Prepared By: Paul Shelor

07/26/2022
12:19PM

3. Six large navigation keys for easy access. Navigation keys shall consist of: TEST, BACK, ENTER, and MENU along with UP and DOWN arrows.
4. Full back lit user display with 4 line by 30-character text capabilities. Display menu shall be designed to provide guided major menus and sub menus main menus provided below:
 - a. Shutdown Unit
 - b. Run Status
 - c. Settings
 - d. Alerts/Faults
 - e. Service
 - f. Inputs
 - g. Outputs
 - h. USB
5. The capability for standalone operation with conventional thermostat/sensor or use with building automation systems (BAS) of Carrier i-Vu®, BACnet MS/PT and Carrier Comfort Network® (CCN) systems. No special modules or boards are required for these capabilities. Has the capability to work with Equipment Touch™ and System Touch™ devices and ZS Sensors.
6. The ability to read refrigerant pressures at display or via BAS network of Discharge Pressure and Suction Pressure. The need for traditional refrigerant gages is not required.
7. USB Data Port for flash drive interaction. This will allow the transfer of data for uploads, downloads, perform software upgrades, back-up and restore data and file transfer data such as component number of starts and run hours.
8. Reverse Rotation Protection of compressors if field three phase wiring is misapplied.
9. Provide Service Capabilities of:
 - b. Auto run test
 - c. Manual run test
 - d. Component run hours and starts
 - e. Commissioning reports
 - e. Data logging
 - f. Alarm history
10. Economizer control and diagnostics. Set up economizer operation, receive feedback from actuator. Also meets the most recent California Title 24, ASHRAE 90.1 and IECC Fault Detection and Diagnostic (FDD) requirements.
11. Unit cooling operation down to 40°F (4°C).
12. Controller shall have easy access connections around the controller perimeter area and consist of Mate-N-Lok, terminal block and RJ style modular jack connections.
13. 365 day real time clock, 20 holiday schedules along with occupied and unoccupied scheduling.
14. Auto-Recognition for easy installation and commissioning of devices like economizers, space sensors etc.
15. A 5°F temperature difference between cooling and heating set points to meet the latest ASHRAE 90.1 Energy Standard.
16. Contain return air sensor, supply air sensor and outdoor air sensor to help monitor and provide data for the unit comfort operation, diagnostic and alarms.
17. Use of Carrier's field accessory hand-held Navigator™ display, Equipment Touch and System Touch devices.
18. Units with the factory-installed Humidi-MiZer® system option are capable of providing multiple modes of improved

Guide Specification for RTU-1, 48FC

Project: CMS Elon, Hawk, Polo Ridge
Prepared By: Paul Shelor

07/26/2022
12:19PM

dehumidification as a variation of the normal cooling cycle.

19. Supply Air Tempering control operates the gas or electric heat to maintain a minimum supply air temperature during conditions where very cold outdoor air causes the supply air temperature to fall below the configured Supply Air Tempering Setpoint. This occurs during periods where DCV is active and increasing the amount of outdoor air or in cases where the system is operating at very low airflow and the calculated economizer position has increased to maintain a constant ventilation rate.
20. Demand limiting in SystemVu™ is achieved through set point expansion. The systems heating and cooling set points are expanded in steps or levels. The degree to which the set points may be expanded is defined by the 6 demand level offsets and the 2 commanded demand limit levels.
21. 3-year limited part warranty.

(23 09 33) Electric and Electronic Control System for HVAC

(23 09 33.13) Decentralized, Rooftop Units:

(23 09 33.13.A.) General:

1. Shall be complete with self-contained low-voltage control circuit protected by a resettable circuit breaker on the 24-v transformer side. Transformer shall have 75VA capability.
2. Shall utilize color-coded wiring.
3. Shall include a Unit Control Board to conveniently and safely provide connection points for vital control functions such as: smoke detectors, phase monitor, gas controller, economizer, thermostat, DDC control options, and low- and high-pressure switches. Controller shall also provide an intuitive means to adjust the indoor fan speed through a simple switch and pot adjustment design.
4. The heat exchanger shall be controlled by an integrated gas controller (IGC) microprocessor. See gas heat section of this specification.
5. Unit shall include a minimum of one 8-pin screw terminal connection board for connection of control wiring.

(23 09 33.13.B.) Safeties:

2. Compressor over-temperature, over-current. High internal pressure differential.
3. Low pressure switch.
 - a. Low pressure switch shall use different color wire than the high-pressure switch. The purpose is to assist the installer and service technician to correctly wire and or troubleshoot the rooftop unit.
4. High pressure switch.
 - b. High pressure switch shall use different color wire than the low-pressure switch. The purpose is to assist the installer and service technician to correctly wire and or troubleshoot the rooftop unit.
5. Mixed air auto re-set temperature switch.
 - c. When return air temperatures get the critical point that can cause compressor reliability issues, this switch will shut down compression only until the temperature raise accordingly. Switch opens at 60°F (16°C) and closes at 65°F (18°C).
6. Automatic reset, motor thermal overload protector.
6. Heating section shall be provided with the following minimum protections:
 - b. High temperature limit switches.
 - c. Induced draft motor speed sensor.
 - d. Flame rollout switch.
 - d. Flame proving controls.

Guide Specification for RTU-1, 48FC

Project: CMS Elon, Hawk, Polo Ridge
Prepared By: Paul Shelor

07/26/2022
12:19PM

(23 09 93) Sequence of Operations for HVAC Controls

(23 09 93.13) Decentralized, Rooftop Units:

(23 09 93.13.A.) INSERT SEQUENCE OF OPERATION

(23 40 13) Panel Air Filters

(23 40 13.13) Decentralized, Rooftop Units:

(23 40 13.13.A.) Standard filter section:

1. Shall consist of factory installed, low velocity, disposable 2 in. thick fiberglass filters of commercially available sizes.
2. Unit shall use only one filter size. Multiple sizes are not acceptable.
3. Filters shall be accessible through a dedicated, weather tight access panel.
4. Four-inch filter capabilities shall be capable with pre-engineered and approved Carrier filter track field installed accessory. This kit requires field furnished filters.

(23 81 19) Self-Contained Air Conditioners

(23 81 19.13) Small-Capacity Self-Contained Air Conditioners:

(23 81 19.13.A.) General:

2. Outdoor, rooftop mounted, electrically controlled, heating and cooling unit utilizing a fully hermetic scroll compressors for cooling duty and gas combustion for heating duty.
3. Factory assembled, single-piece heating and cooling rooftop unit. Contained within the unit enclosure shall be all factory wiring, piping, controls, and special features required prior to field start-up.
4. Unit shall use Puron[®] (R-410A) refrigerant.
5. Unit shall be installed in accordance with the manufacturer's instructions.
7. Unit must be selected and installed in compliance with local, state, and federal codes.

(23 81 19.13.B.) Quality Assurance:

3. Unit meets latest ASHRAE 90.1 minimum efficiency requirements.
4. Unit shall be rated in accordance with AHRI Standards 340/360.
5. Unit shall be designed to conform to ASHRAE 15.
6. Unit shall be UL-tested and certified in accordance with ANSI Z21.47 Standards and UL-listed and certified under Canadian standards as a total package for safety requirements.
8. Insulation and adhesive shall meet NFPA 90A requirements for flame spread and smoke generation.
7. Unit casing shall be capable of withstanding 500-hour salt spray exposure per ASTM B117 (scribed specimen).
8. Unit shall be designed in accordance with ISO 9001 and shall be manufactured in a facility registered by ISO 9001:2015.
9. Roof curb shall be designed to conform to NRCA Standards.
10. Unit shall be subjected to a completely automated run test on the assembly line. The data for each unit will be stored at the factory and must be available upon request.
11. Unit shall be designed in accordance with UL Standard 60335-2-40, including tested to withstand rain.
12. Unit shall be constructed to prevent intrusion of snow and tested to prevent snow intrusion into the control box up to 40 mph.
13. Unit shall be tested to assurance level 1, ASTM D4169 to ensure shipping reliability.

(23 81 19.13.C.) Delivery, Storage, and Handling:

Guide Specification for RTU-1, 48FC

Project: CMS Elon, Hawk, Polo Ridge
Prepared By: Paul Shelor

07/26/2022
12:19PM

4. Unit shall be stored and handled per manufacturer's recommendations.
5. Lifted by crane requires either shipping top panel or spreader bars.
6. Unit shall only be stored or positioned in the upright position.

(2381 19.13.D.) Project Conditions:

5. As specified in the contract.

(2381 19.13.E.) Operating Characteristics:

6. Unit shall be capable of starting and running up to 125°F (52°C) ambient outdoor temperature meeting maximum load criteria of AHRI Standard 210/240 or 340/360 at ±10% voltage.
6. Compressor with standard controls shall be capable of operation down to 40°F (4°C) or 0°F (-18°C) outdoor temperatures. Accessory winter start kit is necessary if mechanically cooling at ambient temperatures down to 25°F (-4°C) or 0°F (-18°C).
7. Unit shall discharge supply air vertically or horizontally as shown on contract drawings.
7. Unit shall be factory configured for vertical supply and return configurations or horizontal supply and return configurations. Dedicated models provided with no special air conversion kits required.

(2381 19.13.F.) Electrical Requirements:

7. Main power supply voltage, phase, and frequency must match those required by the manufacturer.

(2381 19.13.G.) Unit Cabinet:

8. Unit cabinet shall be constructed of galvanized steel and shall be bonderized and coated with a prepainted baked enamel finish on all externally exposed surfaces.
7. Unit cabinet exterior paint shall be: film thickness, (dry) 0.003 inches minimum, gloss (per ASTM D523, 60°F/16°C): 60, Hardness: H-2H Pencil hardness.
8. Evaporator fan compartment interior cabinet insulation shall conform to AHRI Standards 340/360 minimum exterior sweat criteria. Interior surfaces shall be insulated with a minimum 1/2 in. thick, 1 lb. density, flexible fiberglass insulation, neoprene coated on the air side. Aluminum foil-faced fiberglass insulation shall be used in the gas heat compartment.
8. Base of unit shall have a minimum of four locations for thru-the-base gas and electrical connections (factory-installed or field-installed), standard.
9. Base Rail:
 - a. Unit shall have base rails on a minimum of 2 sides.
 - b. Holes shall be provided in the base rails for rigging shackles to facilitate maneuvering and overhead rigging.
 - c. Holes shall be provided in the base rail for moving the rooftop by fork truck.
 - d. Base rail shall be a minimum of 16 gage thickness.
8. Condensate pan and connections:
 - b. Shall be a sloped condensate drain pan made of a corrosion resistant material.
 - c. Shall comply with ASHRAE Standard 62.
 - d. Shall use a 3/4 in. 14 NPT drain connection, possible either through the bottom or side of the drain pan. Connection shall be made per manufacturer's recommendations.
9. Top panel:
 - c. Shall be a multi-top panel linked with watertight flanges and locking systems.
10. Gas Connections:
 - d. All gas piping connecting to unit gas valve shall enter the unit cabinet at a single location on side of unit (horizontal

Schedule calls for stainless steel drain pan

Guide Specification for RTU-1, 48FC

Project: CMS Elon, Hawk, Polo Ridge
Prepared By: Paul Shelor

07/26/2022
12:19PM

plane).

11. Electrical Connections:

- e. All unit power wiring shall enter unit cabinet at a single, factory prepared, knockout location.
- d. Thru-the-base capability.
 - 1) Thru-the-base provisions/connections are available as standard with every unit. When bottom connections are required, field furnished couplings are required.
 - 2) No base pan penetration, other than those authorized by the manufacturer, is permitted.

12. Component access panels (standard):

- a. Cabinet panels shall be easily removable for servicing.
- b. Unit shall have large removable, filter access panel.
- e. Panels covering control box, indoor fan, indoor fan motor, gas components (where applicable), and compressors shall have molded composite handles.
- e. Handles shall be UV modified, composite. They shall be permanently attached and recessed into the panel.
- e. Screws on the vertical portion of all removable access panel shall engage into heat resistant, molded composite collars.
- f. Collars shall be removable and easily replaceable using manufacturer recommended parts.

(2381 19.13.H.) Gas Heat:

1. General:

- a. Heat exchanger shall be an induced draft design. Positive pressure heat exchanger designs shall not be allowed.
- c. Shall incorporate a direct-spark ignition system and redundant main gas valve.
- f. Gas supply pressure at the inlet to the rooftop unit gas valve must match that required by the manufacturer.

2. The heat exchanger shall be controlled by an integrated gas controller (IGC) microprocessor.

- b. IGC board shall notify users of fault using an LED (light-emitting diode).
- b. The LED shall be visible without removing the control box access panel.
- g. IGC board shall contain algorithms that modify evaporator fan operation to prevent future cycling on high temperature limit switch.
- f. Unit shall be equipped with anti-cycle protection with one short cycle on unit flame rollout switch or 4 continuous short cycles on the high temperature limit switch. Fault indication shall be made using an LED.

3. Standard Heat Exchanger construction:

- c. Heat exchanger shall be of the tubular-section type constructed of a minimum of 20-gage steel coated with a nominal 1.2 mil aluminum-silicone alloy for corrosion resistance.
- c. Burners shall be of the in-shot type constructed of aluminum-coated steel.
- c. Burners shall incorporate orifices for rated heat output up to 2000 ft (610 m) elevation. Additional accessory kits may be required for applications above 2000 ft (610 m) elevation, depending on local gas supply conditions.
- g. Each heat exchanger tube shall contain multiple dimples for increased heating effective-ness.

4. Optional Stainless Steel Heat Exchanger construction:

- d. Use energy saving, direct-spark ignition system.
- d. Use a redundant main gas valve.
- d. Burners shall be of the in-shot type constructed of aluminum-coated steel.
- d. All gas piping shall enter the unit cabinet at a single location on side of unit (horizontal plane).

Guide Specification for RTU-1, 48FC

Project: CMS Elon, Hawk, Polo Ridge
Prepared By: Paul Shelor

07/26/2022
12:19PM

- f. The optional stainless steel heat exchanger shall be of the tubular-section type, constructed of a minimum of 20-gage type 409 stainless steel.
 - g. Type 409 stainless steel shall be used in heat exchanger tubes and vestibule plate.
 - g. Complete stainless steel heat exchanger allows for greater application flexibility.
5. Induced draft combustion motor and blower
- e. Shall be a direct-drive, single inlet, forward-curved centrifugal type.
 - e. Shall be made from steel with a corrosion resistant finish.
 - e. Shall have permanently lubricated sealed bearings.
 - e. Shall have inherent thermal overload protection.
 - e. Shall have an automatic reset feature.

(2381 19.13.1.) Coils:

1. Standard Aluminum Fin-Copper Tube Coils:
- a. Standard evaporator and condenser coils shall have aluminum lanced plate fins mechanically bonded to seamless internally grooved copper tubes with all joints brazed.
 - f. Evaporator coils shall be leak tested to 150 psig, pressure tested to 450 psig, and qualified to UL 1995 burst test at 1775 psig.
 - f. Condenser coils shall be leak tested to 150 psig, pressure tested to 650 psig, and qualified to UL 1995 burst test at 1980 psig.
2. Optional Pre-coated aluminum-fin condenser coils:
- b. Shall have a durable epoxy-phenolic coating to provide protection in mildly corrosive coastal environments.
 - b. Coating shall be applied to the aluminum fin stock prior to the fin stamping process to create an inert barrier between the aluminum fin and copper tube.
 - g. Epoxy-phenolic barrier shall minimize galvanic action between dissimilar metals.
 - f. Corrosion durability of fin stock shall be confirmed through testing to be no less than 1000 hours salt spray per ASTM B117-90.
 - f. Corrosion durability of fin stock shall be confirmed through testing to have no visible corrosion after 48 hour immersion in a room temperature solution of 5% salt, 1% acetic acid.
 - h. Fin stock coating shall pass 2000 hours of the following: one week exposure in the prohesion chamber followed by one week of accelerated ultraviolet light testing. Prohesion chamber: the solution shall contain 3.5% sodium chloride and 0.35% ammonium sulfate. The exposure cycle is one hour of salt fog application at ambient followed by one hour drying at 95°F (35°C).
3. Optional Copper-fin evaporator and condenser coils:
- c. Shall be constructed of copper fins mechanically bonded to copper tubes and copper tube sheets.
 - c. Galvanized steel tube sheets shall not be acceptable.
 - c. A polymer strip shall prevent coil assembly from contacting the sheet metal coil pan to minimize potential for galvanic corrosion between coil and pan.
4. Optional E-coated aluminum-fin evaporator and condenser coils:
- d. Shall have a flexible epoxy polymer coating uniformly applied to all coil surface areas without material bridging between fins.
 - d. Coating process shall ensure complete coil encapsulation of tubes, fins and headers.

Guide Specification for RTU-1, 48FC

Project: CMS Elon, Hawk, Polo Ridge
Prepared By: Paul Shelor

07/26/2022
12:19PM

- d. Color shall be high gloss black with gloss per ASTM D523-89.
- d. Uniform dry film thickness from 0.8 to 1.2 mil on all surface areas including fin edges.
- g. Superior hardness characteristics of 2H per ASTM D3363-92A and crosshatch adhesion of 4B-5B per ASTM D3359-93.
- i. Impact resistance shall be up to 160 in. lb. (ASTM D2794-93).
- h. Humidity and water immersion resistance shall be up to minimum 1000 and 250 hours respectively (ASTM D2247-92 and ASTM D870-92).
- h. Corrosion durability shall be confirmed through testing to be no less than 1000 hours salt spray per ASTM B117-90.

(2381 19.13.J.) Refrigerant Components:

1. Refrigerant circuit shall include the following control, safety, and maintenance features:
 - a. Thermostatic Expansion Valve (TXV) shall help provide optimum performance across the entire operating range. Shall contain removable power element to allow change out of power element and bulb without removing the valve body.
 - e. Refrigerant filter drier – Solid core design.
 - e. Service gage connections on suction and discharge lines.
2. Compressors:
 - b. Unit shall use two tandem scroll compressors on single independent refrigeration circuit.
 - b. Units shall have single circuit and two stage cooling and contain two dual stage compressors.
 - f. Evaporator coils shall be a full active design to help better control comfort latent removal.
 - e. Compressor motors shall be cooled by refrigerant gas passing through motor windings.
 - h. Compressors shall be internally protected from high discharge temperature conditions.
 - j. Compressors shall be protected from an over-temperature and over-ampere conditions by an internal, motor overload device.
 - i. Compressor shall be factory-mounted on rubber grommets.
 - i. Compressor motors shall have internal line break thermal, current overload and high-pressure differential protection.
 - i. Crankcase heaters shall not be required for normal operating range, unless required by the manufacturer due to refrigerant charge limits.

(2381 19.13.K.) Return Air Filter Section:

1. Filters access is specified in the unit cabinet section of this specification.
2. Filters shall be held in place by a pivoting filter tray, facilitating easy removal and installation.
3. Shall consist of factory installed, low velocity, throw-away 2 in. thick fiberglass filters.
4. Filters shall be standard, commercially available sizes.
5. Only one size filter per unit is allowed.

(2381 19.13.L.) Evaporator Fan and Motor with EcoBlue™ Technology:

2. **Direct Drive Evaporator fan motor:**
 - a. Shall be an ECM motor design.
 - b. Shall have permanently lubricated bearings.
 - c. Shall have inherent automatic-reset thermal overload protection.
 - d. Shall have slow ramp up to speed capabilities.

Guide Specification for RTU-1, 48FC

Project: CMS Elon, Hawk, Polo Ridge
Prepared By: Paul Shelor

07/26/2022
12:19PM

- e. Shall require no fan/motor belts for operation, adjustments and or initial fan speed set up.
 - k. Fan DC voltage set up on Unit Control Board can eliminate the need of removal of blower access door, required on conventional belt drive systems.
 - j. Shall be internally protected from electrical phase reversal and loss.
2. Evaporator Fan:
- b. Shall be easily set with dedicated selection switch and adjustment pot on unit control board or through SystemVu™ controller.
 - b. Shall provide two stage cooling capacity control, the indoor fan speed is automatically controlled to meet the code-compliant <66% low fan speed and 100% at full fan speed operation.
 - d. Blower fan shall be a Vane Axial fan design with 75% less moving parts than a conventional belt drive system.
 - e. Shall be constructed of a cast aluminum stator and high impact composite material on stator, rotor and air inlet casing.
 - f. Shall be a patented design with a corrosion resistant material and dynamically balanced.
 - l. Shall have slow ramp up to speed capabilities to help reduce sound and comfort issues typically associated with single speed belt drive systems.
 - k. Units shall contain two separate vane axial fan assemblies.
 - j. Shall be a slide out design with removal of a few support brackets.
3. Shall include an easily accessible Unit Control Board to conveniently and safely provide connection points for vital control functions such as: smoke detectors, phase monitor, gas controller, economizer, thermostat, DDC control options, and low, high and mixed air temperature switches. Controller shall also provide an intuitive means to adjust the indoor fan speed through a simple switch and pot adjustment design.

(2381 19.13.M.) Condenser Fans and Motors:

1. Condenser fan motors:
- a. Shall be a totally enclosed motor.
 - c. Shall use permanently lubricated bearings.
 - c. Shall have inherent thermal overload protection with an automatic reset feature.
 - f. Shall use a shaft-down design on all sizes.
2. Condenser Fans:
- b. Shall be a direct-driven propeller type fan.
 - b. Shall have galvalum blades riveted to steel spider that have corrosion-resistant properties and shall be dynamically balanced.

(2381 19.13.N.) Special Features Options and Accessories:

1. Integrated EconoMi\$er® IV, EconoMi\$er2, and EconoMi\$er X Low Leak rate models. (EconoMi\$er IV is only available as a field-installed accessory – this design only allows single speed fan operation.)
- a. Integrated, gear driven opposing modulating blade design type capable of simultaneous economizer and compressor operation.
 - c. Independent modules for vertical or horizontal return configuration shall be available. Vertical return modules shall be available as a factory installed option.
 - d. Damper blades shall be galvanized steel with composite gears. Plastic or composite blades on intake or return shall not be acceptable.
 - g. Shall include all hardware and controls to provide free cooling with outdoor air when temperature and/or humidity are below setpoints.

Guide Specification for RTU-1, 48FC

Project: CMS Elon, Hawk, Polo Ridge
Prepared By: Paul Shelor

07/26/2022
12:19PM

- g. Shall be equipped with gear driven dampers for both the outdoor ventilation air and the return air for positive air stream control.
 - m. Standard leak rate shall be equipped with dampers not to exceed 2% leakage at 1 in. wg pressure differential.
 - l. Economizer controller on EconoMiSer IV models shall be Honeywell W7212 that provides:
 - 1) Combined minimum and DCV maximum damper position potentiometers with compressor staging relay.
 - 2) Functions with solid-state analog enthalpy or dry bulb changeover control sensing.
 - 3) LED indicators for: when free cooling is available, when module is in DCV mode, when exhaust fan contact is closed.
 - k. Economizer controller on EconoMiSer X models shall be the Honeywell W7220 that provides:
 - 2) 2-line LCD interface screen for setup, configuration and troubleshooting.
 - 3) On-board Fault Detection and Diagnostics (FDD) that senses and alerts when the economizer is not operating properly, per California Title 24, ASHRAE 90.1 and IECC.
 - 4) Sensor failure loss of communication identification.
 - 4) Automatic sensor detection.
 - 5) Capabilities for use with multiple-speed or single speed indoor fan systems.
 - 6) Utilize digital sensors: Dry bulb and Enthalpy.
 - j. Economizer controller on EconoMiSer 2 models with SystemVu™ controls shall be a 4 to 20mA design controlled directly by the controller. SystemVu controller meets California Title 24, ASHRAE 90.1 and IECC Fault Detection and Diagnostic (FDD) requirements.
 - j. Shall be capable of introducing up to 100% outdoor air.
 - k. Shall be equipped with a barometric relief damper capable of relieving up to 100% return air and contain seals that meet ASHRAE 90.1 requirements.
 - l. Shall be designed to close damper(s) during loss-of-power situations with spring return built into motor.
 - m. Dry bulb outdoor air temperature sensor shall be provided as standard. Enthalpy sensor is also available on factory-installed economizers only. Outdoor air sensor setpoint shall be adjustable and shall range from 40°F to 100°F (4°C to 38°C). Additional sensor options shall be available as accessories.
 - n. The economizer controller shall also provide control of an accessory power exhaust unit function. Factory set at 100%, with a range of 0% to 100%.
 - o. The economizer shall maintain minimum airflow into the building during occupied period and provide design ventilation rate for full occupancy.
 - p. Dampers shall be completely closed when the unit is in the unoccupied mode.
 - q. Economizer controller shall accept a 2 to 10 Vdc CO₂ sensor input for IAQ/DCV control. In this mode, dampers shall modulate the outdoor air damper to provide ventilation based on the sensor input.
 - r. Compressor lockout temperature on W7220 control is adjustable from -45°F to 80°F (-43°C to 27°C), set at a factory default of 32°F (0°C). W7212 control opens at 35°F (2°C) and closes at 50°F (10°C).
 - s. Actuator shall be direct coupled to economizer gear. No linkage arms or control rods shall be acceptable.
 - t. Economizer controller shall provide indications when in free cooling mode, in the DCV mode, or the exhaust fan contact is closed.
2. Integrated EconoMiSer®2, and EconoMiSer X Ultra Low Leak rate models.
- a. Integrated, gear driven opposing modulating blade design type capable of simultaneous economizer and compressor operation.

Guide Specification for RTU-1, 48FC

Project: CMS Elon, Hawk, Polo Ridge
Prepared By: Paul Shelor

07/26/2022
12:19PM

- b. Independent modules for vertical or horizontal return configuration shall be available. Vertical return modules shall be available as a factory installed option.
 - c. Damper blades shall be galvanized steel with composite gears. Plastic or composite blades on intake or return shall not be acceptable.
 - d. Shall include all hardware and controls to provide free cooling with outdoor air when temperature and/or humidity are below setpoints.
 - e. Shall be equipped with gear driven dampers for both the outdoor ventilation air and the return air for positive air stream control.
 - f. Ultra-Low Leak design meets California Title 24 section 140.4 and ASHRAE 90.1 requirements for 4 cfm per sq. ft on the outside air dampers and 10 cfm per sq. ft on the return dampers.
 - m. Economizer controller on EconoMi\$er X models shall be the Honeywell W7220 that provides:
 - 1) 2-line LCD interface screen for setup, configuration and troubleshooting.
 - 2) On-board Fault Detection and Diagnostics (FDD) that senses and alerts when the economizer is not operating properly, per California Title 24, ASHRAE 90.1 and IECC.
 - 3) Sensor failure loss of communication identification.
 - 4) Automatic sensor detection.
 - 5) Capabilities for use with multiple-speed indoor fan systems.
 - 6) Utilize digital sensors: Dry bulb and Enthalpy.
 - l. Economizer controller on EconoMi\$er 2 models with SystemVu™ controls shall be a 4-20mA design controlled directly by the controller. SystemVu controller meets California Title 24, ASHRAE 90.1 and IECC Fault Detection and Diagnostic (FDD) requirements.
 - k. Shall be capable of introducing up to 100% outdoor air.
 - k. Shall be equipped with a barometric relief damper capable of relieving up to 100% return air and contain seals that meet ASHRAE 90.1 requirements.
 - l. Shall be designed to close damper(s) during loss-of-power situations with spring return built into motor.
 - m. Dry bulb outdoor air temperature sensor shall be provided as standard. Enthalpy sensor is also available on factory-installed economizers only. Outdoor air sensor setpoint shall be adjustable and shall range from 40°F to 100°F (4°C to 38°C). Additional sensor options shall be available as accessories.
 - n. The economizer controller shall also provide control of an accessory power exhaust unit function. Factory set at 100%, with a range of 0% to 100%.
 - o. The economizer shall maintain minimum airflow into the building during occupied period and provide design ventilation rate for full occupancy.
 - p. Dampers shall be completely closed when the unit is in the unoccupied mode.
 - q. Economizer controller shall accept a 2 to 10 vdc CO₂ sensor input for IAQ/DCV control. In this mode, dampers shall modulate the outdoor air damper to provide ventilation based on the sensor input.
 - r. Compressor lockout temperature on W7220 control is adjustable from -45°F to 80°F (-43°C to 27°C), set at a factory default of 32°F (0°C). W7212 control opens at 35°F (2°C) and closes at 50°F (10°C).
 - s. Actuator shall be direct coupled to economizer gear. No linkage arms or control rods shall be acceptable.
 - t. Economizer controller shall provide indications when in free cooling mode, in the DCV mode, or the exhaust fan contact is closed.
3. Two-Position Damper (Field-installed only):
- a. Damper shall be a Two-Position Damper. Damper travel shall be from the full closed position to the field adjustable

Guide Specification for RTU-1, 48FC

Project: CMS Elon, Hawk, Polo Ridge
Prepared By: Paul Shelor

07/26/2022
12:19PM

- %-open set-point.
 - b. Damper shall include adjustable damper travel from 25% to 100% (full open).
 - c. Damper shall include single or dual blade, gear driven dampers and actuator motor.
 - d. Actuator shall be direct coupled to damper gear. No linkage arms or control rods shall be acceptable.
 - e. Damper will admit up to 100% outdoor air for applicable rooftop units.
 - f. Damper shall close upon indoor (evaporator) fan shutoff and/or loss of power.
 - n. The damper actuator shall plug into the rooftop unit's wiring harness plug. No hard wiring shall be required.
 - m. Outside air hood shall include aluminum water entrainment filter.
4. Manual damper (Field-installed only):
- b. Manual damper package shall consist of damper, air inlet screen, and rain hood which can be preset to admit up to 25 or 50% outdoor air for year-round ventilation.
5. Humidi-MiZer® Adaptive Dehumidification System:
- c. The Humidi-MiZer Adaptive Dehumidification System shall be factory installed and shall provide greater dehumidification of the occupied space by two modes of dehumidification operations in addition to its normal design cooling mode:
 - 1) Subcooling mode further sub cools the hot liquid refrigerant leaving the condenser coil when both temperature and humidity in the space are not satisfied.
 - 2) Hot gas reheat mode shall mix a portion of the hot gas from the discharge of the compressor with the hot liquid refrigerant leaving the condenser coil to create a two-phase heat transfer in the system, resulting in a neutral leaving air temperature when only humidity in the space is not satisfied.
 - 3) Includes low ambient controller.
6. Low Ambient Control Package:
- a. Controller shall control coil head pressure by condenser fan speed modulation or condenser fan cycling and wind baffles.
 - b. Shall consist of solid-state control and condenser coil temperature sensor to maintain condensing temperature between 90°F (32°C) and 110°F (43°C) at outdoor ambient temperatures down to 0°F (-18°C).
7. Propane Gas Conversion Kit:
- b. Package shall contain all the necessary hardware and instructions to convert a standard natural gas unit for use with liquefied propane, up to 2000 ft (610 m) elevation.
 - c. Additional accessory kits may be required for applications above 2000 ft (610 m) elevation.
8. Condenser Coil Hail Guard Assembly:
- c. Shall protect against damage from hail.
 - d. Shall be either hood style or louvered.
9. Unit-Mounted, Non-Fused Disconnect Switch:
- d. Switch shall be factory installed, internally mounted.
 - e. National Electric Code (NEC) and UL approved non-fused switch shall provide unit power shutoff.
 - c. Shall be accessible from outside the unit.
 - d. Shall provide local shutdown and lockout capability.
 - e. Sized only for the unit as ordered from the factory. Does not accommodate field-installed devices.
10. Convenience Outlet:

Guide Specification for RTU-1, 48FC

Project: CMS Elon, Hawk, Polo Ridge
Prepared By: Paul Shelor

07/26/2022
12:19PM

- e. Powered convenience outlet.
 - 1) Outlet shall be powered from main line power to the rooftop unit.
 - 2) Outlet shall be powered from line side or load side of disconnect by installing contractor, as required by code. If outlet is powered from load side of disconnect, unit electrical ratings shall be UL certified and rated for additional outlet amperage.
 - 3) Outlet shall be factory-installed and internally mounted with easily accessible 115-v female receptacle.
 - 4) Outlet shall be factory-installed and internally mounted with easily accessible 115-v female receptacle.
 - 5) Voltage required to operate convenience outlet shall be provided by a factory installed step-down transformer.
 - 6) Outlet shall be accessible from outside the unit.
 - 7) Outlet shall include a field installed "Wet in Use" cover.
- b. Factory-Installed Non-Powered convenience outlet.
 - 2) Outlet shall be powered from a separate 115/120v power source.
 - 2) A transformer shall not be included.
 - 4) Outlet shall be factory-installed and internally mounted with easily accessible 115-v female receptacle.
 - 5) Outlet shall include 15 amp GFI receptacles with independent fuse protection.
 - 6) Outlet shall be accessible from outside the unit.
 - 7) Outlet shall include a field installed "Wet in Use" cover.
- c. Field-Installed Non-Powered convenience outlet.
 - 3) Outlet shall be powered from a separate 115/120v power source.
 - 3) A transformer shall not be included.
 - 3) Outlet shall be field-installed and internally mounted with easily accessible 115-v female receptacle.
 - 6) Outlet shall include 20-amp GFI receptacles. This kit provides a flexible installation method which allows code compliance for height requirements of the GFCI outlet from the finished roof surface as well as the capability to relocate the outlet to a more convenient location.
 - 7) Outlet shall be accessible from outside the unit.
 - 8) Outlet shall include a field installed "Wet in Use" cover.
- 11. Flue Discharge Deflector:
 - a. Flue discharge deflector shall direct unit exhaust vertically instead of horizontally.
 - b. Deflector shall be defined as a "natural draft" device by the National Fuel and Gas (NFG) code.
- 12. Centrifugal Fan Power Exhaust:
 - b. Power exhaust shall be used in conjunction with an integrated economizer.
 - c. Independent modules for vertical or horizontal return configurations shall be available.
 - c. Power exhaust shall be controlled by economizer controller operation. Exhaust fans shall be energized when dampers open past the 0 to 100% adjustable setpoint on the economizer control.
- 13. Roof Curbs (Vertical):
 - c. Full perimeter roof curb with exhaust capability providing separate air streams for energy recovery from the exhaust air without supply air contamination.
 - d. Formed galvanized steel with wood nailer strip and shall be capable of supporting entire unit weight.

Guide Specification for RTU-1, 48FC

Project: CMS Elon, Hawk, Polo Ridge
Prepared By: Paul Shelor

07/26/2022
12:19PM

- d. Permits installation and securing of ductwork to curb prior to mounting unit on the curb.
- 14. High Altitude Gas Conversion Kit:
 - d. Package shall contain all the necessary hardware and instructions to convert a standard natural gas unit to operate from 2000 to 7000 ft (610 to 2134 m) elevation with natural gas or from 0 to 7000 ft (0 to 2134 m) elevation with liquefied propane.
- 15. Outdoor Air Enthalpy Sensor:
 - e. The outdoor air enthalpy sensor shall be used to provide single enthalpy control. When used in conjunction with a return air enthalpy sensor, the unit will provide differential enthalpy control. The sensor allows the unit to determine if outside air is suitable for free cooling.
- 16. Return Air Enthalpy Sensor:
 - f. The return air enthalpy sensor shall be used in conjunction with an outdoor air enthalpy sensor to provide differential enthalpy control.
- 17. Indoor Air Quality (CO₂) Sensor:
 - g. Shall be able to provide demand ventilation indoor air quality (IAQ) control.
 - e. The IAQ sensor shall be available in duct mount, wall mount, or wall mount with LED display. The setpoint shall have adjustment capability.
- 18. Smoke detectors (factory-installed only):
 - h. Shall be a Four-Wire Controller and Detector.
 - f. Shall be environmental compensated with differential sensing for reliable, stable, and drift-free sensitivity.
 - e. Shall use magnet-activated test/reset sensor switches.
 - d. Shall have tool-less connection terminal access.
 - e. Shall have a recessed momentary switch for testing and resetting the detector.
 - f. Controller shall include:
 - 1) One set of normally open alarm initiation contacts for connection to an initiating device circuit on a fire alarm control panel.
 - 2) Two Form-C auxiliary alarm relays for interface with rooftop unit or other equipment.
 - 3) One Form-C supervision (trouble) relay to control the operation of the Trouble LED on a remote test/reset station.
 - 4) Capable of direct connection to two individual detector modules.
 - 5) Can be wired to up to 14 other duct smoke detectors for multiple fan shutdown applications.
- 19. Winter Start Kit:
 - a. Shall contain a bypass device around the low-pressure switch.
 - b. Shall be required when mechanical cooling is required down to 25°F (-4°C).
 - c. Shall not be required to operate on an economizer when below an outdoor ambient of 40°F (4°C).
- 20. Time Guard:
 - b. Shall prevent compressor short-cycling by providing a 5-minute delay (±2 minutes) before restarting a compressor after shutdown for any reason.
 - c. One device shall be required per compressor.
- 22. Hinged Access Panels:
 - c. Shall provide easy access through hinged access panels with vinyl coated door retainers.

Guide Specification for RTU-1, 48FC

Project: CMS Elon, Hawk, Polo Ridge
Prepared By: Paul Shelor

07/26/2022
12:19PM

- d. Shall be on major panels of: filter, control box, and fan motor.
- 22. 4 in. MERV-13 Return Air filters:
 - d. Factory option to upgrade standard unit filters to 4 in. MERV-13 filters. Filter media is securely fastened inside the filter frame on all four sides.
- 23. 4 in. filter rack kit:
 - e. The 4 in. filter rack accessory kit is designed to hold 4 in. MERV-8 or MERV-13 filters. Filters not included in kit.
- 24. 2 in. MERV-13 Return Air filters:
 - f. Accessory kit to field upgrade standard unit filters to 2 in. MERV-13 filters.
- 25. 2 in. MERV-8 Return Air filters:
 - g. Accessory kit to field upgrade standard unit filters to 2 in. MERV-8 filters.
- 26. Phase Monitor Control:
 - h. Shall monitor the sequence of three phase electrical system to provide a phase reversal protection.
 - e. Shall monitor the three phase voltage inputs to provide a phase loss protection for the three phase device.
 - d. Will work on either a Delta or Wye power connection.
- 27. Horn/Strobe Annunciator:
 - i. Provides an audible/visual signaling device for use with factory-installed option or field installed accessory smoke detectors.
 - 1) Requires installation of a field-supplied 24-v transformer suitable for 4.2 VA (AC) or 3.0 VA (DC) per horn/strobe accessory.
 - 2) Requires field-supplied electrical box, North American 1-gang box, 2 in. (51 mm) x 4 in. (102 mm).
 - 3) Shall have a clear colored lens.
- 28. UV-C ultraviolet lamp kit:
 - a. High-output, low temperature ultraviolet lamp accessory. It includes:
 - 1) 36 in. lamp, interlock switch, mounting brackets, necessary wires, wire ties, screws and labels to field install kit in unit return air plenum.
 - 3) Separate dedicated 115v power source required.
 - 4) UV-C kit cannot be used on units with Humidi-MiZer® system.
- 29. High Short Circuit Current Rating (SCCR) protection:
 - a. Factory-installed option provides high short circuit current protection to each compressor, plus all indoor and outdoor fan motors of 10 kA against high potential fault current situations. (Standard unit comes with 5 kA rating.)
 - b. This option is not available with factory installed Non-Fused Disconnect, Humidi-MiZer system, Low Ambient controls, Phase loss monitor/protection and 575 Volt models.



INTRODUCTION TO DOE 2023 REGULATORY REQUIREMENTS





ecoblue™ technology



75% fewer moving parts



Intuitive fan speed adjustment controls



Up to 40% more energy efficient



No belts or pulleys



No shaft or shaft bearings

CONTENTS:



Introduction	3
Carrier Readiness	4
Commercial Rooftop Unit Rating Comparisons	5
Commercial Split System Rating Comparisons	6
New Technologies	7
New Refrigerant for Rooftop Units	9
Where to Go for More Information	10
Notes	11



Dear Carrier Expert:

We are getting ready for the 2023 regulatory requirements and we want you to be ready too!

On January 1, 2023, the Department of Energy's (DOE) new minimum efficiency standards for commercial packaged air conditioners (ACs) and heat pumps (HPs) will go into effect. These new regulations are part of the DOE's ongoing initiative to reduce overall energy consumption in the United States. These changes will present new complexities, but Carrier is prepared, and we are here to support you through this transition.

HVAC manufacturers will be required to comply with a new testing procedure for developing efficiency ratings. Carrier is committed to leading our industry in compliance and we have developed this comprehensive launch kit to help you fully understand and be prepared for these changes.

The 2023 Regulatory Launch Kit provides information to help you get up to speed with the new requirements, including:

- Minimum efficiency changes
- Regulatory-ready product updates
- New technologies

We are all in this together. As your trusted manufacturer, we will continue to make resources available to you leading up to January 1, 2023. Be sure to visit Carrier's 2023 Regulatory Launch Kit site on [HVACpartners](#) for the most current marketing resources.

Thank you for your support!

CARRIER READINESS

TIME FOR A NEW CHANGE

As the innovative leader in building comfort and the inventor of modern air conditioning, Carrier has thrived by continuously looking for the next advancement in comfort technology. That's why we are always prepared when it's time to meet new, federally mandated minimum efficiency standards.*

Why the Change

Every six years the Department of Energy (DOE) reanalyzes the effects of energy usage, sets minimum efficiency requirements and manages the testing standards by which those efficiencies are measured. In 2018 the DOE started the first phase of their six-year plan requiring a 13% increase in energy efficiency for commercial packaged air conditioners, heat pumps and split systems. The second phase of this plan will start in 2023.



2023 Commercial Minimum Efficiency Change – IEER, COP

Starting on January 1, 2023 all commercial air conditioning and heat pump equipment from 65,000 btu/h to 760,000 btu/h will require an additional 15% efficiency increase from the existing ratings set in 2018. Combined with the efficiency requirements implemented in 2018 this will result in a 30% increase over the six-year period.

Additionally, all gas fired commercial air conditioners will be required to meet an 81% gas efficiency rating

In 2023, there will not be any changes to the testing procedures mandated for commercial air conditioners and heat pumps great than 65,000 btu/h.

2023 Single Phase Commercial – SEER2, EER2 and HSPF2

The DOE has also reanalyzed and adjusted the minimum efficiencies of single-phase air conditioners and heat pumps, 5 tons or less. Single phase and residential products will also be required to comply with a new testing procedure for developing efficiency ratings. Compared to today's test procedure, the external static pressure used when testing will be increased by up to 5X to better reflect field conditions.

Since the new testing requirements are more stringent and reduce the resulting efficiency rating, in 2023, there will be new metrics and nomenclature – SEER2, EER2 and HSPF2. On the same system, compared to SEER ratings, the new SEER2 ratings will be lower and the minimum efficiencies will be reduced to account for the more difficult test procedure.

DOE Enforcement for the Manufacture

After January 1, 2023, Carrier will no longer manufacture any rooftop units that are not compliant with the new DOE energy efficiency mandates. According to 10CFR part 431.97, compliance is only on the date of manufacture – this means any three-phase product produced on 12/31/2022 or earlier is still able to be sold after the compliance date.

Please refer to the residential DOE 2023 regulatory brochure for more details on single phase requirements and enforcement.

COMMERCIAL ROOFTOP UNIT RATING COMPARISONS

COMMERCIAL PACKAGED AIR CONDITIONER AND HEAT PUMP RATINGS

The new 2023 minimum efficiency standards for packaged air commercial air conditioners and heat pumps will increase the minimum efficiency by 15% over the January 1, 2018 efficiency standards. This second phase of regulatory increases will bring the total efficiency of these air conditioning system up by 30% from 2015.

Packaged Air Conditioning Units – Air Cooled Direct Expansion			
Equipment Type		Existing January 1, 2018	New January 1, 2023
Small Commercial Packaged AC's (≥ 65,000 Btu/h < 135,000 Btu/h)	Electric Resistance or No Heating	12.9 IEER	14.8 IEER
	All Other Types of Heating	12.7 IEER	14.6 IEER
Large Commercial Packaged AC's (≥ 135,000 Btu/h < 240,000 Btu/h)	Electric Resistance or No Heating	12.4 IEER	14.2 IEER
	All Other Types of Heating	12.2 IEER	14.0 IEER
Very Large Commercial Packaged AC's (≥ 240,000 Btu/h < 760,000 Btu/h)	Electric Resistance or No Heating	11.6 IEER	13.2 IEER
	All Other Types of Heating	11.4 IEER	13.0 IEER

Packaged Air Conditioning Units – Air Cooled Heat Pumps			
Equipment Type		Existing January 1, 2018	New January 1, 2023
Small Commercial Packaged AC's (≥ 65,000 Btu/h < 135,000 Btu/h)	Electric Resistance or No Heating	12.2 IEER, 3.3 COP	14.1 IEER, 3.4 COP
	All Other Types of Heating	12.0 IEER, 3.3 COP	13.9 IEER, 3.4 COP
Large Commercial Packaged AC's (≥ 135,000 Btu/h < 240,000 Btu/h)	Electric Resistance or No Heating	11.6 IEER, 3.2 COP	13.5 IEER, 3.3 COP
	All Other Types of Heating	11.4 IEER, 3.2 COP	13.3 IEER, 3.3 COP
Very Large Commercial Packaged AC's (≥ 240,000 Btu/h < 760,000 Btu/h)	Electric Resistance or No Heating	10.6 IEER	NA

3 to 5 Tons Packaged Air Conditioning Units – Air Cooled DX and Heat Pumps			
Equipment Type		Three Phase*	Single Phase
Small Commercial Packaged AC's (< 65,000 Btu/h)	All Heat Types	14 SEER, 8.0 HSPF	13.4 SEER2, 6.7 HSPF2

*Three phase 3-5 ton models have the same efficiency as existing models today. There is no change for SEER or HSPF for three phase models, only single phase is moving to SEER2 and HSPF2. Please refer to the residential DOE 2023 regulatory brochure for more details on SEER2 and HSPF2.

COMMERCIAL SPLIT SYSTEM RATING COMPARISONS

COMMERCIAL SPLIT AIR CONDITIONER AND HEAT PUMP RATINGS

The new 2023 minimum efficiency standards for split air commercial air conditioners and heat pumps will increase the minimum efficiency by 15% over the January 1, 2018 efficiency standards. This second phase of regulatory increases will bring the total efficiency of these air conditioning system up by 30% from 2015.

Commercial Split Air Conditioning Units – Air Cooled Direct Expansion			
Equipment Type		Existing January 1, 2018	New January 1, 2023
Small Commercial Split AC's (≥ 65,000 Btu/h < 135,000 Btu/h)	Electric Resistance or No Heating	12.9 IEER	14.8 IEER
	All Other Types of Heating	12.7 IEER	14.6 IEER
Large Commercial Split AC's (≥ 135,000 Btu/h < 240,000 Btu/h)	Electric Resistance or No Heating	12.4 IEER	14.2 IEER
	All Other Types of Heating	12.2 IEER	14.0 IEER
Very Large Commercial Split AC's (≥ 240,000 Btu/h < 760,000,000 Btu/h)	Electric Resistance or No Heating	11.6 IEER	13.2 IEER
	All Other Types of Heating	11.4 IEER	13.0 IEER

Commercial Split Air Conditioning Units – Air Cooled Heat Pumps			
Equipment Type		Existing January 1, 2018	New January 1, 2023
Small Commercial Split AC's (≥ 65,000 Btu/h < 135,000 Btu/h)	Electric Resistance or No Heating	12.2 IEER, 3.3 COP	14.1 IEER, 3.4 COP
	All Other Types of Heating	12.0 IEER, 3.3 COP	13.9 IEER, 3.4 COP
Large Commercial Split AC's (≥ 135,000 Btu/h < 240,000 Btu/h)	Electric Resistance or No Heating	11.6 IEER, 3.2 COP	13.5 IEER, 3.3 COP
	All Other Types of Heating	11.4 IEER, 3.2 COP	13.3 IEER, 3.3 COP
Very Large Commercial Split AC's (≥ 240,000 Btu/h < 760,000,000 Btu/h)	Electric Resistance or No Heating	10.6 IEER, 3.2 COP	12.5 IEER, 3.2 COP
	All Other Types of Heating	10.4 IEER, 3.2 COP	12.3 IEER, 3.2 COP

What It All Means

Breaking down the numbers, the 2023 efficiency standards represent a 15% energy efficiency increase from current standards, across the board. Many of our current products already meet or exceed the minimum efficiency standards set for 2023. We have been working for several years in anticipation of these changes and are ready to increase the efficiency of our remaining product lines before the new standards take effect on January 1, 2023.

NEW TECHNOLOGIES

ECOBBLUE™ TECHNOLOGY

As we continue to look for measured improvements in the energy efficiency and performance of our heating and cooling systems leading up to 2023, we continue to expand our EcoBlue technology across our product lines.

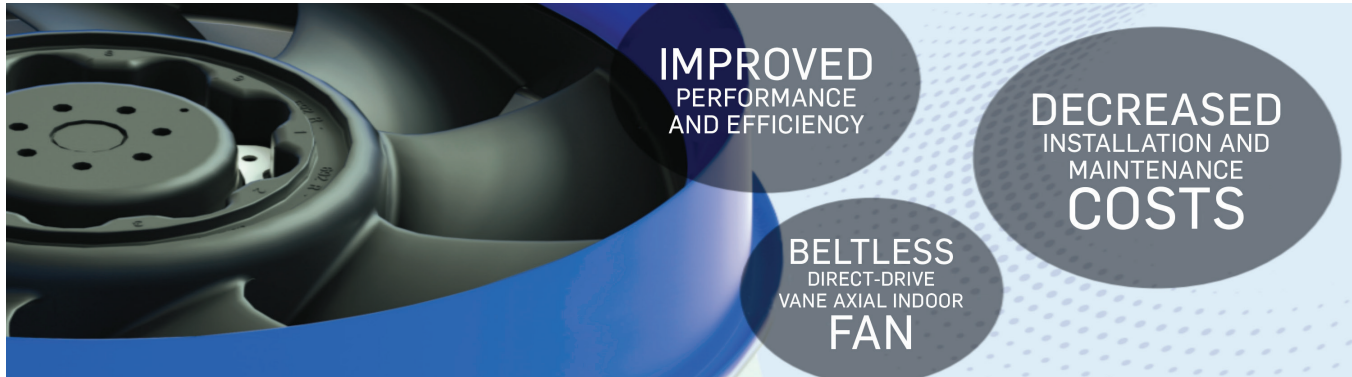

Currently the EcoBlue direct drive vane axial fan systems with EC motors only exist on our 3–6 ton, small rooftop units. This technology will soon be available on all small and medium light commercial rooftop units up to 27.5 tons. EcoBlue Technology has been designed to improve performance and efficiency while decreasing maintenance and installation costs.

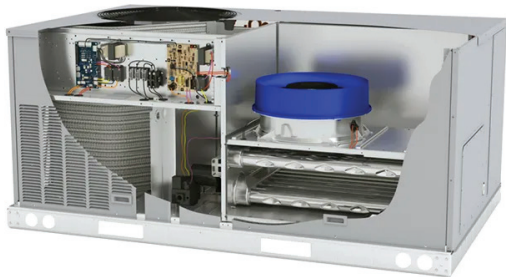

Most notable of EcoBlue Technology's many features is the exclusive beltless direct-drive vane axial fan system an industry first for rooftop units. This patent-pending technology replaces traditional belts and pulleys with a simpler, more compact design, all with 75 percent fewer moving parts. The outdoor fan system's high-density composite blade fan is also an exclusive design. Other technological advances that differentiate these units include: a new control board and coil technology, increased factory options and a tool-less filter access door.

- Units with EcoBlue Technology are up to 60 percent more efficient than RTUs of 17 years ago, and 40% more efficient than traditional forward curve fans today. This ensures lower operating costs while increasing the opportunity for utility rebates.
- 75% fewer moving parts compared to traditional fans. No fan belts, pulleys, shafts and bearings.
- Maintaining our historical footprints while increasing energy efficiency, allows for faster, easier, and less costly replacement opportunities
- In addition, optional SystemVu controls bring the benefits of smarter diagnostics by providing ongoing, real-time information to help ensure the efficient operation and optimum performance of the unit.

Split System with EcoBlue Fans

Carrier is expanding the use of the highly efficient EcoBlue direct drive fan system into the Commercial Split System market. All 6 to 10 ton split system air handlers will soon be available with direct drive vane axial fans. All of the same efficiencies and convenience of the EcoBlue fan system apply to the 40RU product line.



Multistage – Single Circuit Design

Carrier rooftop units will continue to utilize a single circuit Multistage compression system across our product lines that is designed to increase energy efficiency and heat transfer rates across the condenser coil. Using the full surface of the condenser coil throughout full load or part load conditions allows our units to achieve greater cooling efficiencies without the need to increase the footprint of the unit.

NEW TECHNOLOGIES

Thermal Expansion Valves - TXVs

The use of Thermal Expansion Valves will take over for the older style fixed orifice metering devices in our light commercial 6 to 27.5 tons rooftop units. A TXV is capable of operating more efficiently at part load conditions compared to a fixed orifice system due to its ability to precisely control the rate of refrigerant flow based on the temperatures and load of the system.

While a fixed orifice metering device will always deliver a fixed amount of refrigerant regardless of system load, a smart system using a TXV can avoid operating with improper refrigerant levels and reduce the amount of resulting temperature swings. TXV's will not only greatly impact energy efficiency of the system but also increase the durability of the refrigeration system as well as occupant comfort.

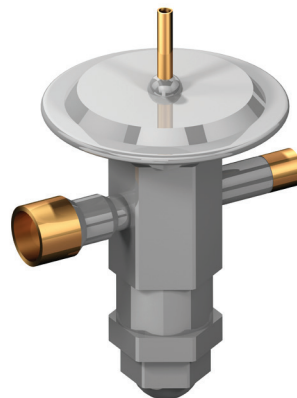

SystemVu™

Carrier rooftop units will continue to offer the SystemVu controller, which is designed to enhance energy efficiency and occupant comfort control. The controller's capability to utilize advanced sequences and staging techniques ensure the connected systems are operating at their most efficient point and making the most of part load hours. SystemVu also provides superior reliability and diagnostic capabilities including historical.

The SystemVu controller's intuitive display menu allows quick and easy access to more than 300 possible configuration points and more than 300 status, troubleshooting, diagnostic and maintenance points. A USB port makes data exchanging easy and accurate, further enhancing one of the most efficient packaged rooftop product lines.



Energy Recovery

Another exciting product that will be used to boost energy efficiency is the EnergyX® integrated factory installed energy recovery system. This system provides a greater degree of operational and application flexibility while providing high system efficiencies and enhanced operational control, all with a packaged rooftop unit. This energy recovery system will not only boost energy efficiency but provide extra cooling capacity, dehumidification, heating capacity and can even allow the entire system to be downsized.

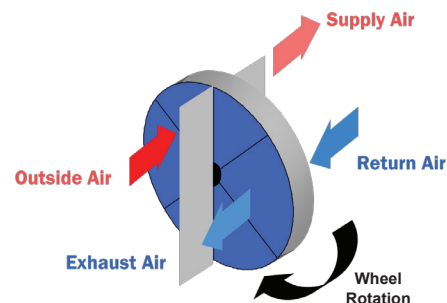

NEW REFRIGERANT FOR ROOFTOP UNITS



A New Refrigerant for a New Standard

In a worldwide effort to address climate change concerns, global leaders have proposed a phase down of high Global Warming Potential (GWP) refrigerants as a part of the Kigali Amendment to the United Nations' Montreal Protocol. Although the United States as a whole has not yet ratified this agreement, states involved in the U.S. Climate Alliance* are embracing the reductions. Based on proposed California regulations, it is anticipated that many U.S. states will be limiting the GWP for refrigerants used in HVAC applications at a maximum of 750, possibly as early as 2025.

Our current Puron® refrigerant, while excellent at providing a non-ozone-depleting alternative to R-22, has a GWP of 2088, well above the anticipated future limit. That is why we are in the process of developing new products that will use Puron Advance™ refrigerant. The new Puron Advance is composed of R-454B, a blend of R-32 and R-1234yf. It has a much lower GWP — 465 — which easily surpasses the proposed 2025 requirement. And, it will continue to meet the anticipated future Kigali phase down requirements well into the 2030s.

What's the Big Difference?

Puron Advance falls into a new classification on the American Society of Heating, Refrigerating and Air-Conditioning Engineers (ASHRAE) Standard 34 flammability and toxicity matrix — A2L. A2L refrigerants are classified by ASHRAE as having lower toxicity and lower flammability. Our current Puron refrigerant, R-410A, falls into the A1 category for refrigerants with no ignition at or below 60° C. And while that makes A2Ls more flammable than A1s, such as R-410A, they are still much less flammable than natural gas or propane. According to AHRI research studies, the risk of fire remains low. Here's why:

- A2Ls, like Puron Advance, are hard to ignite (they require significant ignition energy) so they will not be ignited by static electricity
- A significant leak of an A2L, such as Puron Advance, would be required to reach a flammable concentration of 11.8% lower flame limit (LFL)
- Concentrations of A2Ls, like Puron Advance, below the LFL will only burn while passing through a flame and will not ignite and sustain a flame
- If an unlikely ignition does occur, the resulting energy is very low with a burning velocity of about 2.0 inches per second

ASHRAE Standard 34 Safety Classes

Higher Flammability	A3 Propane, Butane	B3
Flammable	A2 Methylene Fluoride	B2 Methyl Chloride
Lower Flammability	A2L Puron ADVANCE™	B2L Ammonia
No Flame Propagation at 60° C	A1 Puron	B1 Sulfur Dioxide
	Lower Toxicity (OEL of 400 ppm or greater)	Higher Toxicity (OEL of less than 400 ppm)
	Increasing Toxicity	

As an added precaution, Carrier will add safety features in all systems containing Puron Advance which could include leak detection sensors and mitigation procedures.

The change to Puron Advance is just that — a change. But since it will meet regulatory requirements far into the future, it should be a change that lasts quite a while. As we move forward with implementing Puron Advance, Carrier will support you all along the way making the transition as smooth as possible.

WHERE TO GO FOR MORE INFORMATION

Make the Commitment

Remember, we ALL have a stake in this. As your trusted supplier, we will invest the time and resources to make compliance as easy as possible. That includes training, updated product labeling, and continued communications about this topic.

In the end, we encourage you to make the commitment as well. Start preparing now by getting up to speed on the upcoming 2023 regulations and taking advantage of your resources. If you have any questions regarding the new 2023 regulations, reach out to your local distributor.



HVAC PARTNERS

HVAC Partners

Visit HVACpartners.com for access to the 2023 Regulatory Launch Kit page. Visit often, as we will be adding new product information and regulatory details to the site as they become available.

Go to: *HVACpartners > Marketing Tools > Sales Tools > Marketing Launch Kits > 2023 Regulatory*

Content includes:

- 2023 Readiness Flyer
- 2023 Regulatory Resource Guide
- 2023 Regulatory Readiness Sales PPT



Other Resources

- U.S. Department of Energy – www.energy.gov
- U.S. Environmental Protection Agency – www.epa.gov
- EPA and DOE Energy Efficiency – www.energystar.gov
- U.S. Government's national archives – www.federalregister.gov



www.carrier.com/commercial

1-800-CARRIER

©2022 Carrier. All Rights Reserved.

Cat No. 04-811-90044

Manufacturer reserves the right to discontinue, or change at any time, specifications or designs without notice or without incurring obligations.
All trademarks and service marks referred herein are property of their respective owners.