

HVAC PLAN NOTES

- SEE ARCHITECTURAL REFLECTED CEILING PLAN FOR CEILING MOUNTED EQUIPMENT LOCATION. TYPICAL.
- PAINT DUCTWORK VISIBLE THROUGH DINING ROOM SUPPLY REGISTERS BLACK. TYPICAL.
- PENETRATIONS THROUGH SHEAR WALL SHALL BE LIMITED TO 10" DIAMETER (OR A GROUP OF PENETRATIONS ALL CONTAINED WITHIN 10" DIAMETER). IF LARGER PENETRATIONS OR GROUPS OF PENETRATIONS ARE REQUIRED COORDINATE WITH STRUCTURAL ENGINEER FOR APPROPRIATE BRACING. SEE STRUCTURAL DRAWINGS FOR SHEAR WALL LOCATION.
- 26/18 DUCT UP FOR TRANSITION TO RTU-1 RETURN CONNECTION IN ROOF CURB. RTU-1 SHALL HAVE AN INTEGRAL SMOKE DETECTOR MOUNTED IN THE RETURN AIR STREAM. INTERLOCK SMOKE DETECTOR TO RTU-1 OPERATION.
- 26/18 DUCT UP FOR TRANSITION TO RTU-2 RETURN CONNECTION IN ROOF CURB. RTU-2 SHALL HAVE AN INTEGRAL SMOKE DETECTOR MOUNTED IN THE RETURN AIR STREAM. INTERLOCK SMOKE DETECTOR TO RTU-2 OPERATION.
- 26/18 DUCT UP FROM BUILDING SUPPLY THROUGH ROOF. TRANSITION TO RTU-1 SUPPLY CONNECTION IN ROOF CURB.
- 26/18 DUCT UP FROM BUILDING SUPPLY TO RTU-2 SUPPLY CONNECTION. TRANSITION IN ROOF CURB.
- 14/14 DUCT UP THROUGH ROOF. TRANSITION TO MAU-1 SUPPLY CONNECTION IN ROOF CURB.
- 16/16 DUCT UP FROM HOOD THROUGH ROOF TO EF-1 COMPLIANT WITH NFPA 96. PROVIDE RADIUSED ELBOWS WITH AN INSIDE RADIUS OF 0.5W AT ELBOWS IN GREASE DUCT.
- 8/6 DUCT UP THROUGH ROOF TO EF-2.
- 28/12 DUCT DOWN TO MAKEUP AIR PDP DUCT CONNECTION. TRANSITION TO SUPPLY PLENUM OPENING SIZE TYPICAL FOR 12".
- 8" DIA. DUCT DOWN TO AC PDP DUCT CONNECTION. TRANSITION TO SUPPLY PLENUM OPENING SIZE. TYPICAL. CAP UNUSED DUCT CONNECTIONS.
- INSTALL GRIDPOINT THERMOSTATS FURNISHED BY TEMS FOR RTU-1 (TS200) AND RTU-2 (TS200) AT THIS LOCATION AT 48" AFF. COORDINATE WITH ELECTRICAL SWITCHING IN THIS AREA. PROVIDE THERMOSTAT WIRING FROM EACH THERMOSTAT TO THE CORRESPONDING ROOFTOP UNIT. PROVIDE CATSE CABLE FROM RTU-1 TS200 TO J-BOX #2 ABOVE ELECTRICAL PANELS (LEAVE 16" OF CABLE COILED UP INSIDE OF J-BOX #2 ND 16" BEHIND WALL OF THERMOSTAT FOR FINAL CONNECTION TO THE EMS SYSTEM BY THE TEMS) AND LABEL BOTH ENDS OF CABLE "TSTATS". SEE GRIDPOINT INSTALLATION INSTRUCTIONS FOR TERMINATION INSTRUCTIONS.
- INSTALL GRIDPOINT ZONE SENSOR MODULE FURNISHED BY TEMS FOR RTU-1 AT THIS LOCATION 84" AFF DIRECTLY TO WALL (NO JUNCTION BOX). COORDINATE LOCATION WITH EQUIPMENT. PROVIDE 18G-24G SHIELDED TWISTED PAIR FROM ZSM TO RTU-1 THERMOSTAT T1 TERMINALS. SEE GRIDPOINT INSTALLATION INSTRUCTIONS FOR TERMINATION INSTRUCTIONS.
- INSTALL GRIDPOINT ZONE SENSOR MODULE FURNISHED BY TEMS FOR RTU-2 AT THIS LOCATION 60" AFF DIRECTLY TO WALL (NO JUNCTION BOX). COORDINATE LOCATION WITH EQUIPMENT. PROVIDE 18G-24G SHIELDED TWISTED PAIR FROM ZSM TO RTU-2 THERMOSTAT T1 TERMINALS. SEE GRIDPOINT INSTALLATION INSTRUCTIONS FOR TERMINATION INSTRUCTIONS.
- INSTALL GRIDPOINT SUPPLY PROBE FURNISHED BY TEMS FOR RTU-1 IN THE SUPPLY DUCTWORK UPSTREAM FROM THE FIRST BRANCH CONNECTION. PROVIDE 18G-24G SHIELDED TWISTED PAIR FROM SUPPLY PROBE TO RTU-1 THERMOSTAT T2 TERMINALS. SEE GRIDPOINT INSTALLATION INSTRUCTIONS FOR TERMINATION INSTRUCTIONS.
- INSTALL GRIDPOINT SUPPLY PROBE FURNISHED BY TEMS FOR RTU-2 IN THE SUPPLY DUCTWORK UPSTREAM FROM THE FIRST BRANCH CONNECTION. PROVIDE 18G-24G SHIELDED TWISTED PAIR FROM SUPPLY PROBE TO RTU-2 THERMOSTAT T2 TERMINALS. SEE GRIDPOINT INSTALLATION INSTRUCTIONS FOR TERMINATION INSTRUCTIONS.
- INSTALL REMOTE TEMPERATURE SENSOR FOR HOOD HD-1 AT THIS LOCATION 84" AFF. COORDINATE LOCATION WITH EQUIPMENT. PROVIDE (2) #18 G. THERMISTOR CABLE FROM TEMPERATURE SENSOR TO HOOD CONTROL PANEL.

HVAC PLAN NOTES

- INSTALL KITCHEN HOOD, HD-1. SUPPORT HOOD PER MANUFACTURER'S INSTALLATION INSTRUCTIONS AND AS DETAILED IN THE ARCHITECTURAL AND STRUCTURAL DRAWINGS. INSTALL HOOD ACCORDING TO THE REQUIREMENTS OF ITS LISTING, IN COMPLIANCE WITH NFPA 96, THE BUILDING CODE, AND AUTHORITIES HAVING JURISDICTION. HOOD SHALL HAVE AN INTEGRAL DUCT COLLAR TEMPERATURE SENSOR TO AUTOMATICALLY ENERGIZE THE EXHAUST AND MAKEUP AIR FANS IF COOKING TEMPERATURES ARE DETECTED. EXHAUST DUCT SYSTEM TO BE WELDED OR FACTORY-MANUFACTURED WATER AND AIR TIGHT. INSTALL CLEANOUTS PER CODE AND AS SHOWN. INSTALL HOOD PER DETAILS 2 AND 4/M700. CHIPOTLE WILL PROVIDE AN INDEPENDENT TESTING AGENCY FOR TESTING THE INTEGRITY OF THE GREASE DUCT SYSTEM.
- INSTALL REMOTE CONDENSING UNIT FOR WALK-IN COOLER ON ROOF AS DETAILED IN THE ARCHITECTURAL AND STRUCTURAL DRAWINGS. CMG VENDOR TO INSTALL REFRIGERANT LINE SET, THERMOSTATIC EXPANSION VALVE, SOLENOID VALVE, TEMPERATURE CONTROL, SIGHT GLASS, FILTER DRIER, PRESSURE CONTROL, LOW AMBIENT CONTROLS, AND WEATHERPROOF HOUSING. TRAP AND SLOPE REFRIGERANT LINES PER MANUFACTURER'S RECOMMENDATIONS. INSTALLATION SHALL COMPLY WITH ASHRAE/ANSI STANDARD 15. INSTALL THE REFRIGERANT LINE SET UNDER THE ROOF DECK TO WITHIN 3' OF THE CONDENSING UNIT. CUT 2-1/2" HOLE IN WALK-IN COOLER ROOF FOR REFRIGERANT LINE SET AND SEAL PER THE COOLER MANUFACTURER'S INSTALLATION INSTRUCTIONS AFTER LINE SET IS INSTALLED.
- INSTALL REMOTE CONDENSER FOR ICE MACHINE ON ROOF AS DETAILED IN THE ARCHITECTURAL AND STRUCTURAL DRAWINGS. CMG VENDOR TO INSTALL REFRIGERANT LINE SET, THERMOSTATIC EXPANSION VALVE, SOLENOID VALVE, TEMPERATURE CONTROL, SIGHT GLASS, FILTER DRIER, PRESSURE CONTROL, LOW AMBIENT CONTROLS, AND WEATHERPROOF HOUSING. TRAP AND SLOPE REFRIGERANT LINES PER MANUFACTURER'S RECOMMENDATIONS. SEAL PIPING PENETRATIONS THROUGH ROOF. INSTALLATION SHALL COMPLY WITH ASHRAE/ANSI STANDARD 15. INSTALL THE REFRIGERANT LINE SET UNDER THE ROOF DECK TO WITHIN 3' OF THE REMOTE CONDENSER. IF REFRIGERANT PIPING TO ICE MAKER IS EXPOSED TO PUBLIC VIEW CONCEAL WITHIN A STAINLESS STEEL SHROUD AS SHOWN IN THE ARCHITECTURAL DRAWINGS.
- INSTALL ROOFTOP EQUIPMENT PER MANUFACTURER'S INSTALLATION INSTRUCTIONS AND AS DETAILED IN THE ARCHITECTURAL AND STRUCTURAL DRAWINGS.
- INSTALL EXHAUST FAN EF-1 PER DETAIL 5/M700 AND AS DETAILED IN THE ARCHITECTURAL AND STRUCTURAL DRAWINGS. INSTALL GREASE VIROGUARD SYSTEM FURNISHED BY CHIPOTLE ON EXHAUST FAN, EF-1.
- PROVIDE SUPPLY DIFFUSER CONNECTION TO SUPPLY SYSTEM PER DETAIL 1/M700. TYPICAL.
- PROVIDE AUDIO/VISUAL REMOTE SMOKE DETECTOR ANNUNCIATOR WITH REMOTE KEY OPERATED RESET. WIRE A UNIT BACK TO EACH SMOKE DETECTOR. MOUNT UNIT 60" AFF. TYPICAL.
- INSTALL REME HALO AIR PURIFIER FURNISHED BY TUV IN RTU PER DETAIL 6/M700. SEE ELECTRICAL DRAWINGS FOR POWER CONNECTION INFORMATION. INSTALL UV WARNING STICKERS ON FACE OF ENCLOSURE PER DETAIL AND ON ANY RTU ACCESS DOOR(S) THROUGH WHICH THE REME HALO WOULD BE VISIBLE IF OPENED.
- MAINTAIN 10' CLEARANCE BETWEEN WATER HEATER FLUE TERMINATION AND OUTSIDE AIR INTAKES. MAINTAIN 10' CLEARANCE BETWEEN WATER HEATER COMBUSTION AIR INTAKE AND EXHAUST FAN EF-1 DISCHARGE. SEE PLUMBING DRAWINGS FOR MORE INFORMATION ON WATER HEATER FLUE AND COMBUSTION AIR TERMINATIONS.
- ADJUST SUPPLY REGISTERS SO THAT SUPPLY AIR HITS WALL ON OPPOSITE SIDE OF ROOM AT APPROXIMATELY 7' AFF WITH NO DRAFTS FELT IN THE DINING ROOM.

Revisions:	REVISION 1
1 11/11/24	REVISION 1
3 07/15/25	Construction Set

6 M100
HVAC DINING ROOM RETURN SECTION
1/4" = 1'-0"

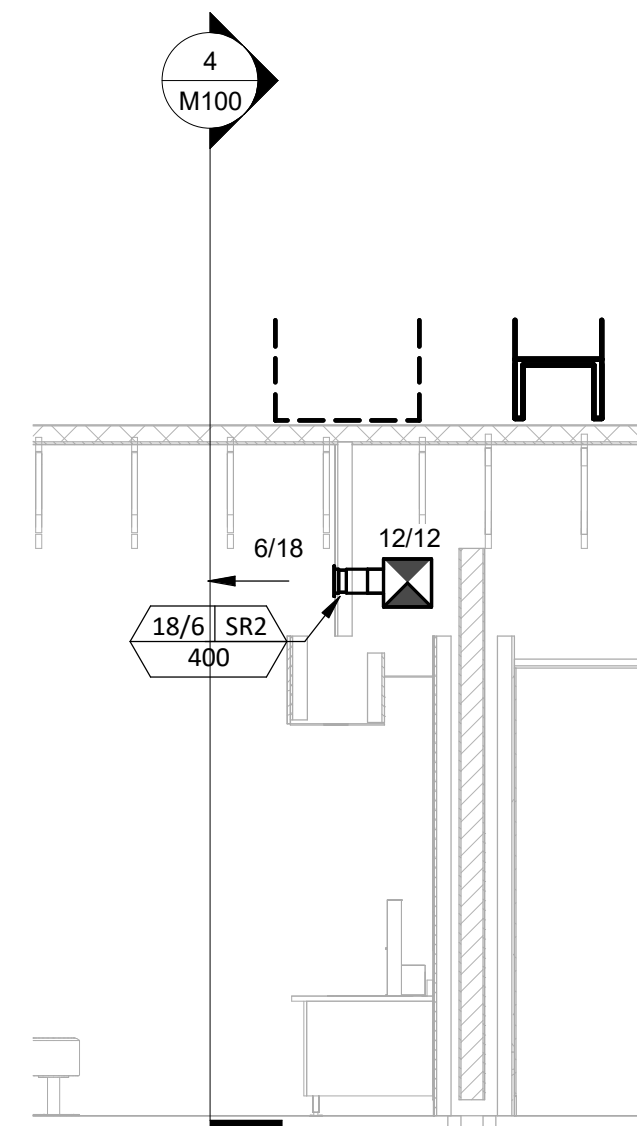

5 M100
HVAC DINING ROOM SECTION
1/4" = 1'-0"

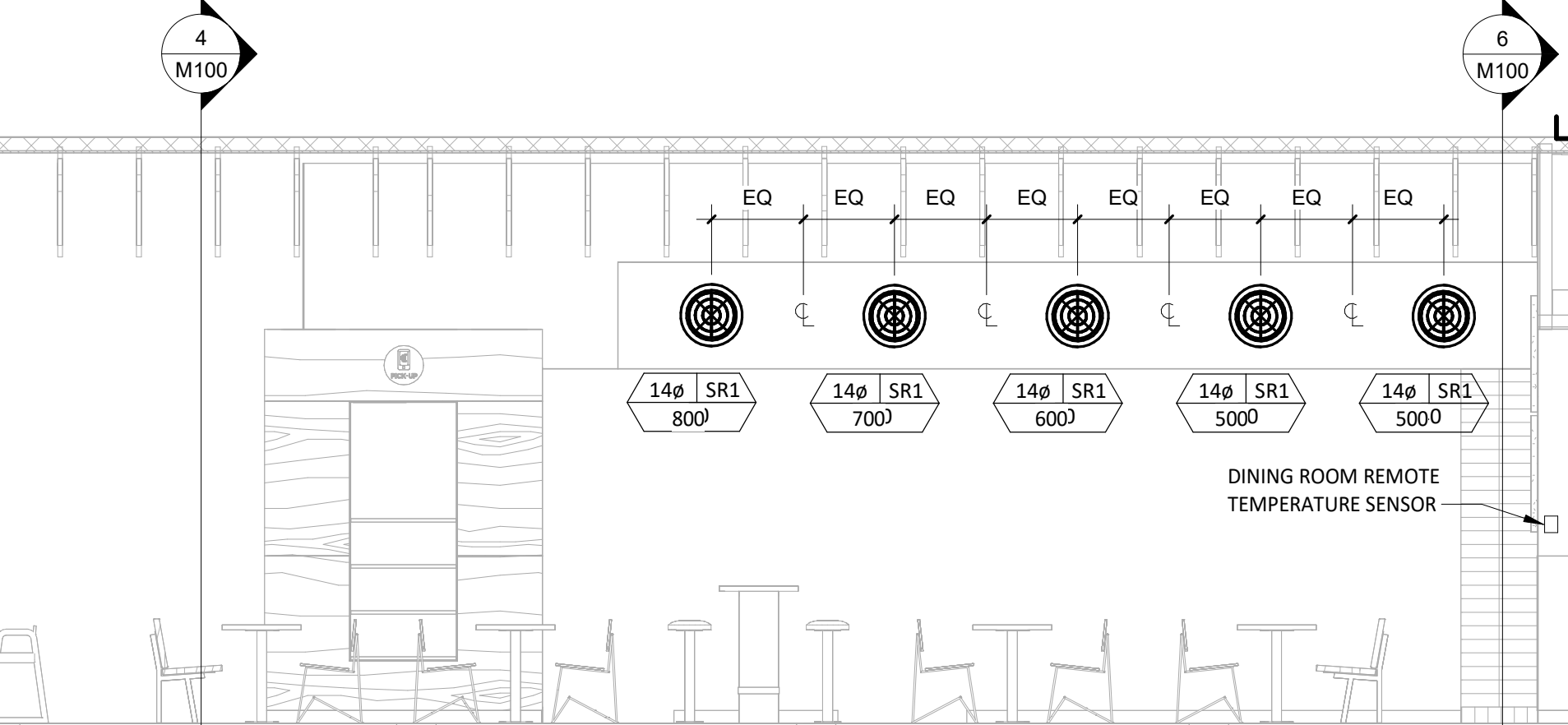

3 M100
HVAC DINING ROOM SECTION
1/4" = 1'-0"

4 M100
HVAC DINING ROOM SECTION
1/4" = 1'-0"

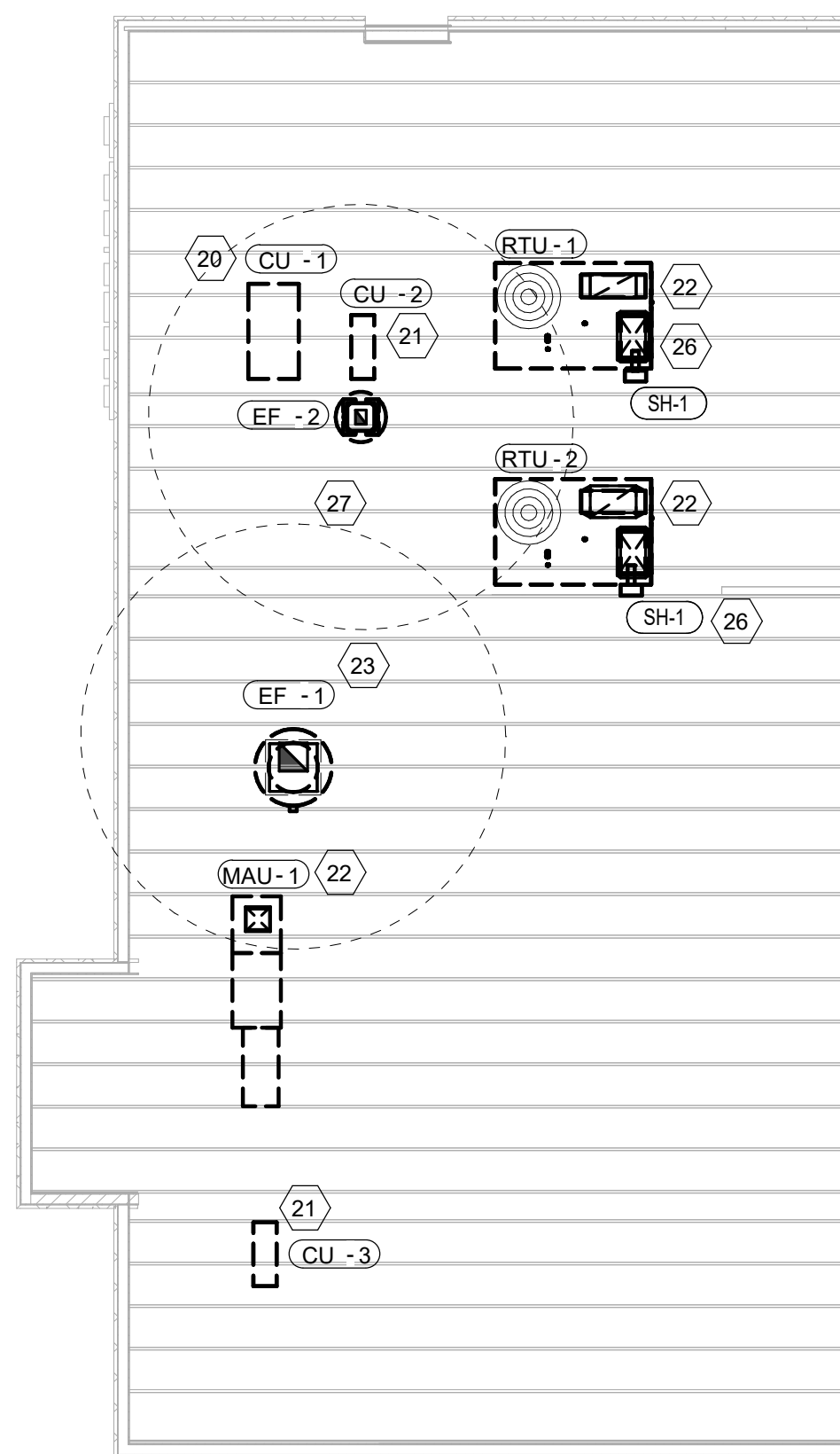
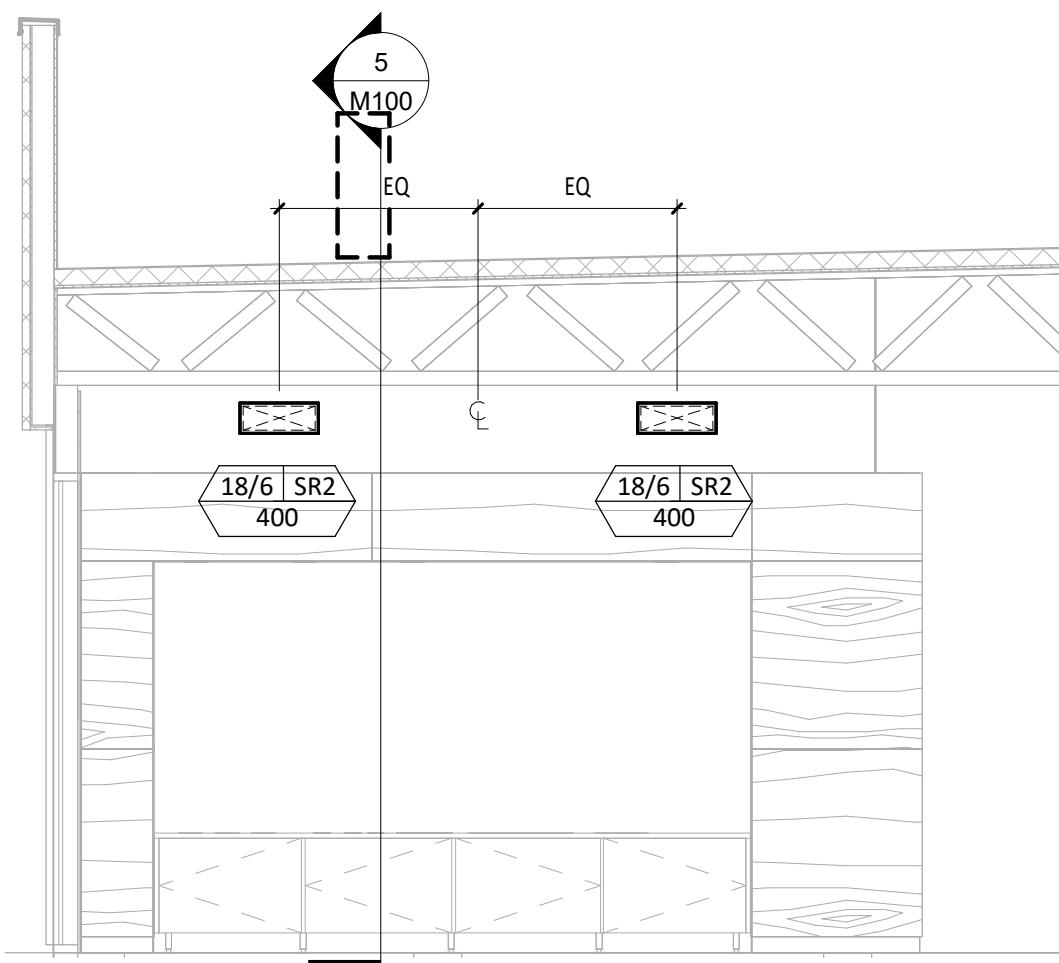

2 M100
HVAC ROOF PLAN
1/8" = 1'-0"

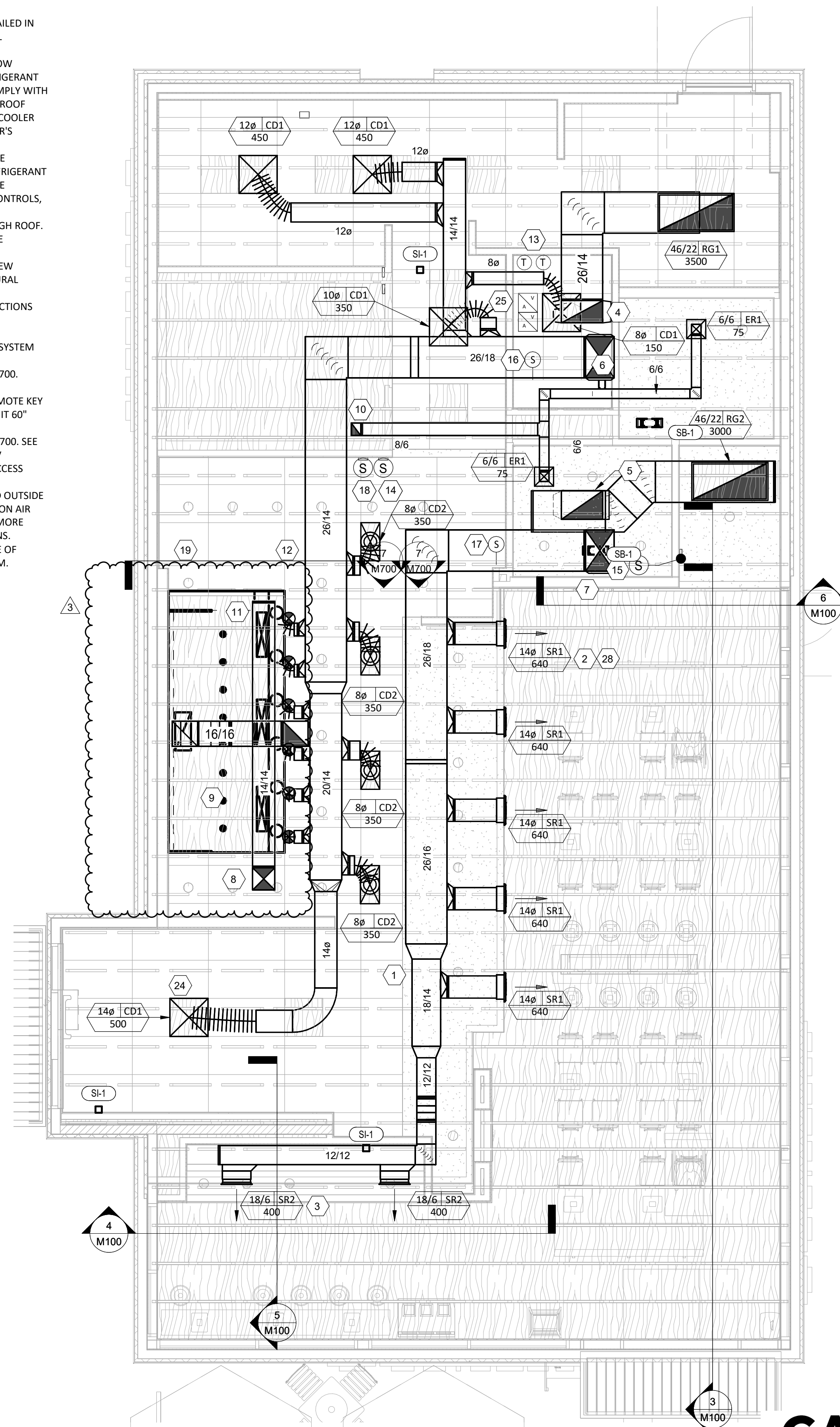

1 M100
HVAC FLOOR PLAN
1/4" = 1'-0"

Direct Drive Upblast Centrifugal Roof Exhaust Fan

MARK INFORMATION		FAN INFORMATION						MOTOR INFORMATION					
QTY	MARK	MODEL	VOLUME (CFM)	TOTAL EXTERNAL SP (IN WG)	FAN RPM	OPERATING POWER (HP)	WEIGHT (LB.)	SIZE (HP)	V/C/P	ENCLOSURE	MOTOR RPM	WINDINGS	NEC FLA*
1	EF-1 (Hood-1)	XCUE-160-VG	2,550	1.2	1,330	0.87	106	2	208/60/1	TF	1725	1	13.2

*NEC FLA - Based on table 430.250 or 430.248 of National Electrical Code 2020. Actual motor FLA may vary for sizing thermal overload, consult factory

EF-1 (Hood-1) : SELECTED OPTIONS AND ACCESSORIES

One piece fully welded windband
 Tapered bushing wheel hub
 Breather tube outlet area min. 4.4 sq. in. (sizes 99-480), 2.0 sq. in. (sizes 60-95)
 Min. windband material thickness: 0.051" aluminum (060-240), 0.064" aluminum (240HP, 240XP), 0.080" aluminum (sizes 300-480)
 Larger Curb Cap Size - 26 Square
 UL/cUL 705 Listed - Supplement SC - "Power Ventilators for Restaurant Exh. Appliances" (Formerly UL 762)
 Switch, NEMA-3R, Toggle,
 Aluminum Wheel Material

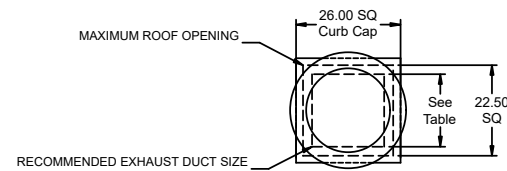

DUCT TYPE	SIZE
STANDARD	18 SQ
FIRE-WRAPPED	12 SQ

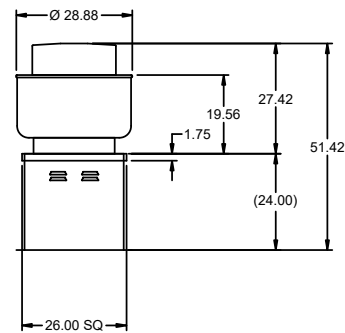

DUCT DIMENSIONS ARE LARGEST POSSIBLE DUCT TO FIT THROUGH CURB. CONSULT SYSTEM DESIGN ENGINEER FOR RECOMMENDED DUCT SIZE.

OVERALL HEIGHT MAY BE GREATER DEPENDING ON MOTOR, ADAPTER, AND/OR HINGE BASE.

SHOP DRAWING REVIEW

- NO EXCEPTIONS TAKEN
- MAKE CORRECTIONS NOTED
- REVISE AND RESUBMIT
- REJECTED

REVIEW IS FOR GENERAL COMPLIANCE WITH CONTRACT DOCUMENTS AND SPECIFICATIONS. NO RESPONSIBILITY IS ASSUMED BY THIS ENGINEER. THE CONTRACTOR IS RESPONSIBLE FOR CORRECTNESS OF QUANTITIES, DIMENSIONS AND DETAILS

CASE
Engineering Inc.

796 Merus Court
St. Louis, MO 63026
T 636.349.1600
F 636.349.1730

BY: JW

DATE: 11-04-2024

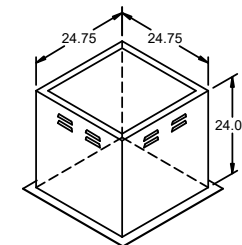

PROJECT/ 10/17/2024
MARK
CHIPOTLE-SARATOGA 5244

MARK
EF-1 (HOOD-1)

DIRECT CHAIN ACX - 2283
JOE AYOUB
JOE.AYOUB@ACCUREX.COM
(857)272-8727

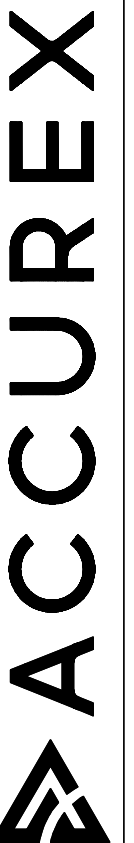

HOOD INFORMATION																	
HOOD NO.	MARK	MODEL	HOOD DIMENSIONS (IN.)			HOOD CONSTR.	COOKING LOAD / DUTY RATING	EXHAUST					SUPPLY		HANGING WEIGHT LBS.	SECTION LOCATION	
			LENGTH	WIDTH	HEIGHT			TOTAL CFM	COLLAR(S)			MUA CFM	AC CFM				
1	HOOD-1	XXEW-153-S	153	54	24	430 SS WHERE EXPOSED	HEAVY	2550	10	24		2550	0.483	1300	700	732	SINGLE

HOOD INFORMATION															
HOOD NO.	MARK	LIGHTING DETAILS				GREASE FILTRATION DETAILS				UTILITY CABINET(S)					
		FIXTURE TYPE	BULB / LAMP INFO	QTY	FOOT CANDLES	TYPE / MODEL MATERIAL	QTY	SIZE (IN.)	LOCATION	FIRE SYSTEM		CONTROLS			
1	HOOD-1	INCANDESCENT (GLOBE)	100W A19 (BULBS NOT INCL.)	8	54.77	X-TRACTOR (SPARK ARRESTOR INCL.) STAINLESS STEEL	2	16	20	RIGHT	ANSUL R102	6	XKC	TOUCHSCREEN	

SUPPLY PLENUM INFORMATION																		
HOOD NO.	MARK	POS.	TYPE	SIZE (IN.)			INSULATED	DAMPER(S)	LED LIGHT(S)		TOTAL CFM	TOTAL S.P.	COLLARS					
				L	W	H			SUPPLIED	QTY			TYPE	MOUNTING	QTY	W	L	DIA.
1	HOOD-1	FRONT	SPLIT ASF	82.5	14	4	NO	NO		650	0	MUA	FACTORY	2	12	28	325	139
				82.5	10	4	YES	YES		350	0.02	AC	FACTORY	3			117	335
1	HOOD-1	FRONT	SPLIT ASF	82.5	14	4	NO	NO		650	0	MUA	FACTORY	2	12	28	325	139
				82.5	10	4	YES	YES		350	0.02	AC	FACTORY	3			117	335

HOOD OPTIONS

- UL 710 LISTED W/ OUT EXHAUST FIRE DAMPER - UL #R25625
- BACK INTEGRAL AIR SPACE - 3 IN WIDE - ZERO CLEARANCE
- 10 IN HIGH CEILING ENCLOSURES - FRONT LEFT RIGHT - FIELD INSTALLED
- FACTORY MOUNTED EXHAUST COLLAR(S)
- LEFT INSULATED END PANEL WITH ADJUSTABLE LEG 80 IN HIGH 27.00 IN TOP WIDTH 21.0 IN BOTTOM WIDTH
- RIGHT INSULATED END PANEL WITH ADJUSTABLE LEG 80 IN HIGH 27.00 IN TOP WIDTH 21.0 IN BOTTOM WIDTH
- PERFORMANCE ENHANCING LIP (PEL) TECHNOLOGY
- STANDING SEAM CONSTRUCTION FOR SUPERIOR STRENGTH

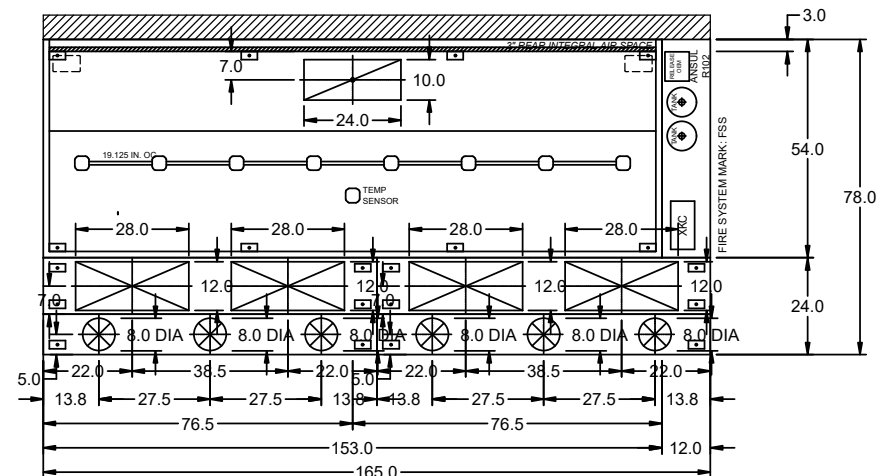

Fire (piping/drops/nozzles/etc.) subject to change. As built's can be provided at time of order and included with product shipment

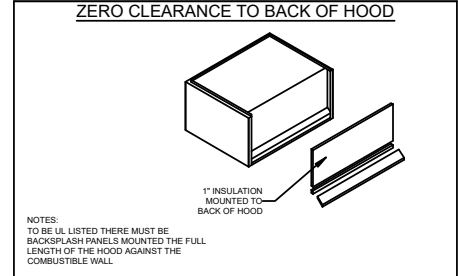
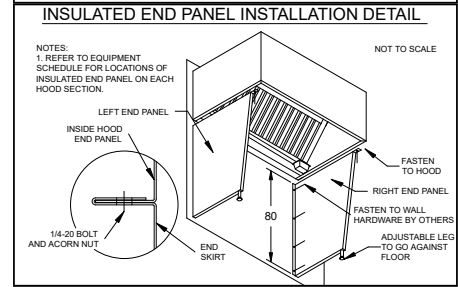
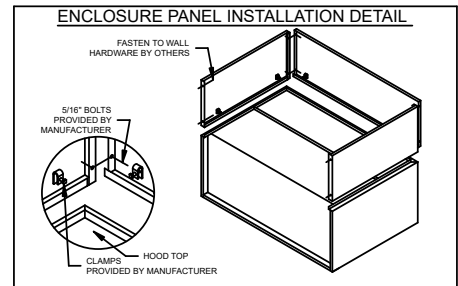
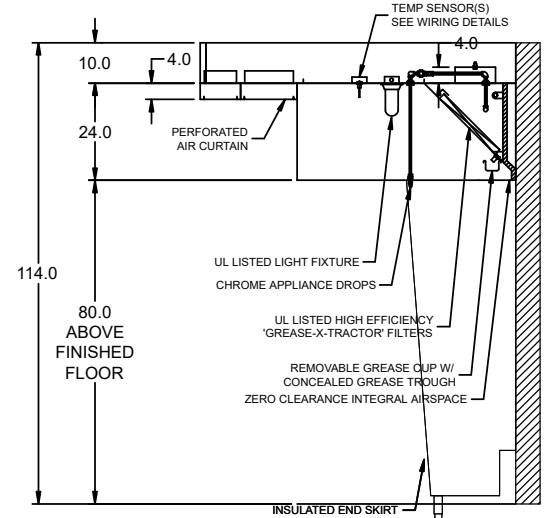
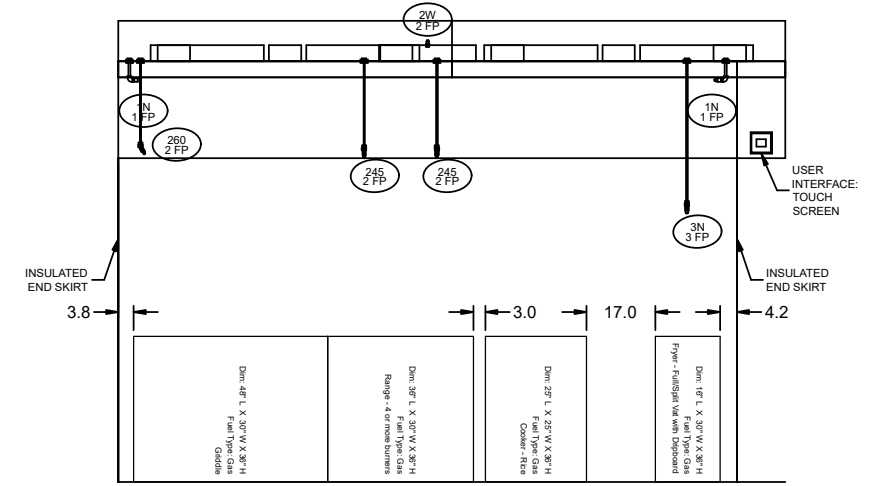

HOOD HANGING HEIGHT FOR FIRE SYSTEMS
 VERIFICATION OF HOOD HANGING HEIGHT ABOVE FINISHED FLOOR (A.F.F.) IS REQUIRED FOR CORRECT PLACEMENT OF FIRE SYSTEM NOZZLES.

- RECOMMENDED HANGING HEIGHT = 80" FROM FINISHED FLOOR TO LOWER FRONT EDGE OF HOOD.
- OTHER HANGING HEIGHT = * FROM FINISHED FLOOR TO LOWER EDGE OF HOOD.

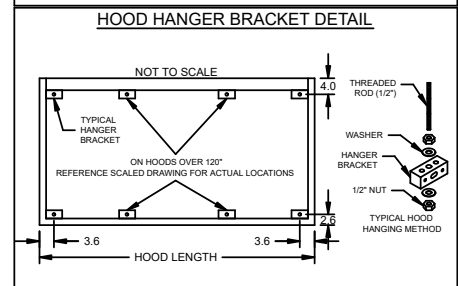
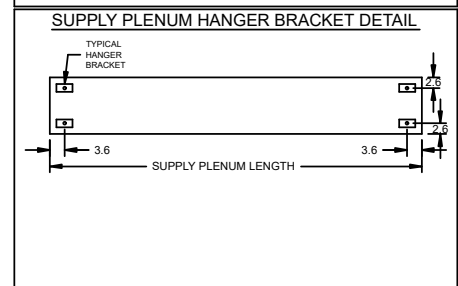

Direct Drive Centrifugal Roof Exhaust Fan

MARK INFORMATION		FAN INFORMATION						MOTOR INFORMATION					
QTY	MARK	MODEL	VOLUME (CFM)	TOTAL EXTERNAL SP (IN WG)	FAN RPM	OPERATING POWER (HP)	WEIGHT (LB.)	SIZE (HP)	V/C/P	ENCLOSURE	MOTOR RPM	WINDINGS	NEC FLA*
1	EF-2 (Restroom)	XRED-097-VG	150	0.6	1,330	0.05	43	0.25	115/60/1	TN	1725	1	5.8

*NEC FLA - Based on table 430.250 or 430.248 of National Electrical Code 2020. Actual motor FLA may vary for sizing thermal overload, consult factory"

EF-2 (Restroom) : SELECTED OPTIONS AND ACCESSORIES

Standard Curb Cap Size - 19 Square
 UL/cUL 705 Listed - "Power Ventilators"
 Switch, NEMA-1, Toggle,
 Damper Shipped Loose, BD-100-PB-12X12, Gravity Operated, Not Coated, Nominal Size
 Birdscreen: Galvanized, nom. 84% Free Area
 Conduit Chase Qty 1

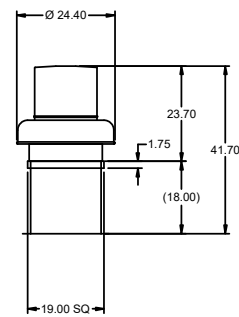
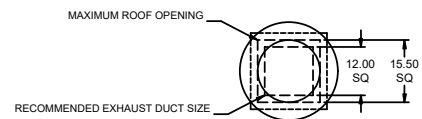

DUCT DIMENSIONS ARE LARGEST POSSIBLE DUCT TO FIT THROUGH CURB.
 CONSULT SYSTEM DESIGN ENGINEER FOR RECOMMENDED DUCT SIZE.
 OVERALL HEIGHT MAY BE GREATER DEPENDING ON MOTOR, ADAPTER, AND/OR
 HINGE BASE.

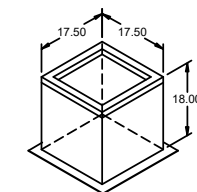
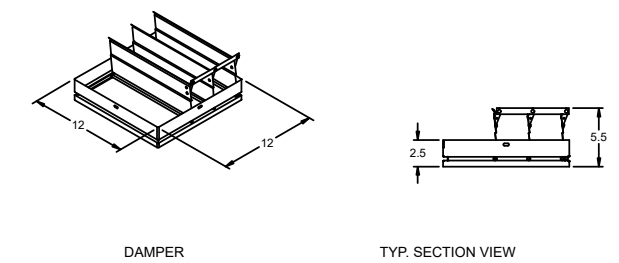

PROJECT
10/17/2024

MARK
EF-2 (RESTROOM)

UL LISTED
COMMERCIAL ROOF EXHAUST FAN

CHIPOTLE-SARATOGA 5244

DIRECT CHAIN ACX - 2283
 JOE AYUB
 JOE.AYUB@ACCUREX.COM
 (857)272-8727

ACCUREX

EQUIPMENT SCHEDULE										OPTIONS AND ACCESSORIES									
Tempered Make-Up Air Unit										Air Flow Arrangement: Outdoor Air Only Weatherhood: Aluminum Mesh, 16x20x2 - (2) Damper: Inlet Outdoor Air Intake Position: End Discharge Position: Bottom Coating: Galvanized Insulation: Double Wall - Tempering On Supply Fan Control: Vari-Green ECM Vari-Green Control: Dial on Motor Access Side: Right-Hand Unit Weight: 421 lb Control Center Heat Inlet Air Sensor External Cooling Lockout Relay Unit Controls: Terminal Strip Temperature Control: Discharge Direct Gas Options/Accessories Approvals: ETL FM Compliant Flame Sensing: Flame Rod Ignition Control: Pilot									
Qty	Accurex Model	Volume	External SP	Total SP	MCA	MOP	Weight	SCCR	Mark: MAU-1										
1	XDGX-P115-H05-VG	1,300 CFM	0.5 in. wg	1,446 in. wg	21.3	35	421 lb	5kA											
Motor Information																			
Size	VIC/P	Enclosure	Motor with Shaft Grounding	Motor RPM	Operating Power														
1 hp	115/60/1	ODP	No	1725	0.68 hp														
Heating																			
Type	Gas Type	Temperature	Energy	Connection	Building	Control	Gas Pressure												
Direct Gas	Natural	Winter DB	Max Δ	Max LAT	Input	Output	Efficiency	Gas (IN)	Gas Pressure	Access	Right	Hand	Min	Max					
		10.0 F	60.0 F	70.0 F	91.6 MBH	84.2 MBH	92%	3/4"	1/2 PSI				7 in. wg	0.5 PSI					

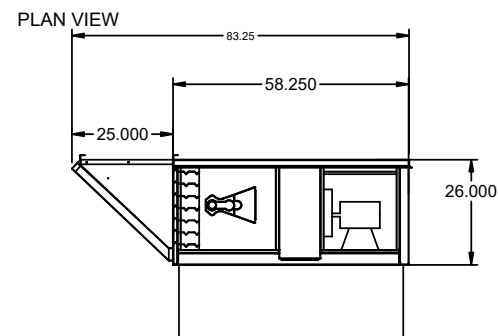
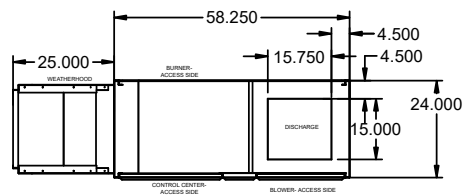

ELEVATION VIEW

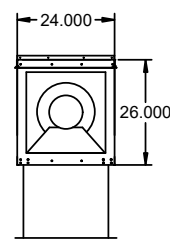

END VIEW

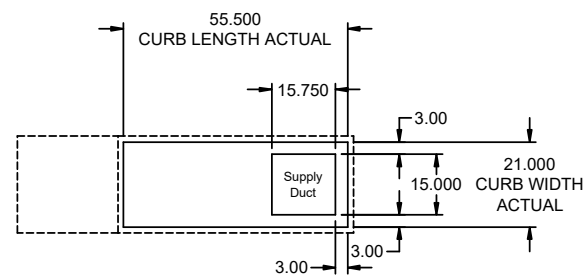

FOOTPRINT

NOTE: Roof Opening Requirements:

Minimum Roof Opening: The minimum roof opening size is the illustrated duct diameter plus 0.25 in. on all sides. For example: If the duct size is 14 x 14 in. square, the minimum roof opening size is 14.5 x 14.5 in. square.

Maximum Roof Opening: There must be a minimum perimeter of 1.75 in. between the roof opening and the roof curb. For example: If the roof curb is 75 x 30 in. square, the maximum roof opening is 71.5 x 26.5 in. inches square.

NOTE: The weatherhood and filter sections of the make-up air unit are not supported by the curb. This is by design, in order to help alleviate water infiltration issues. MUA Unit supports are shipped loose with unit.

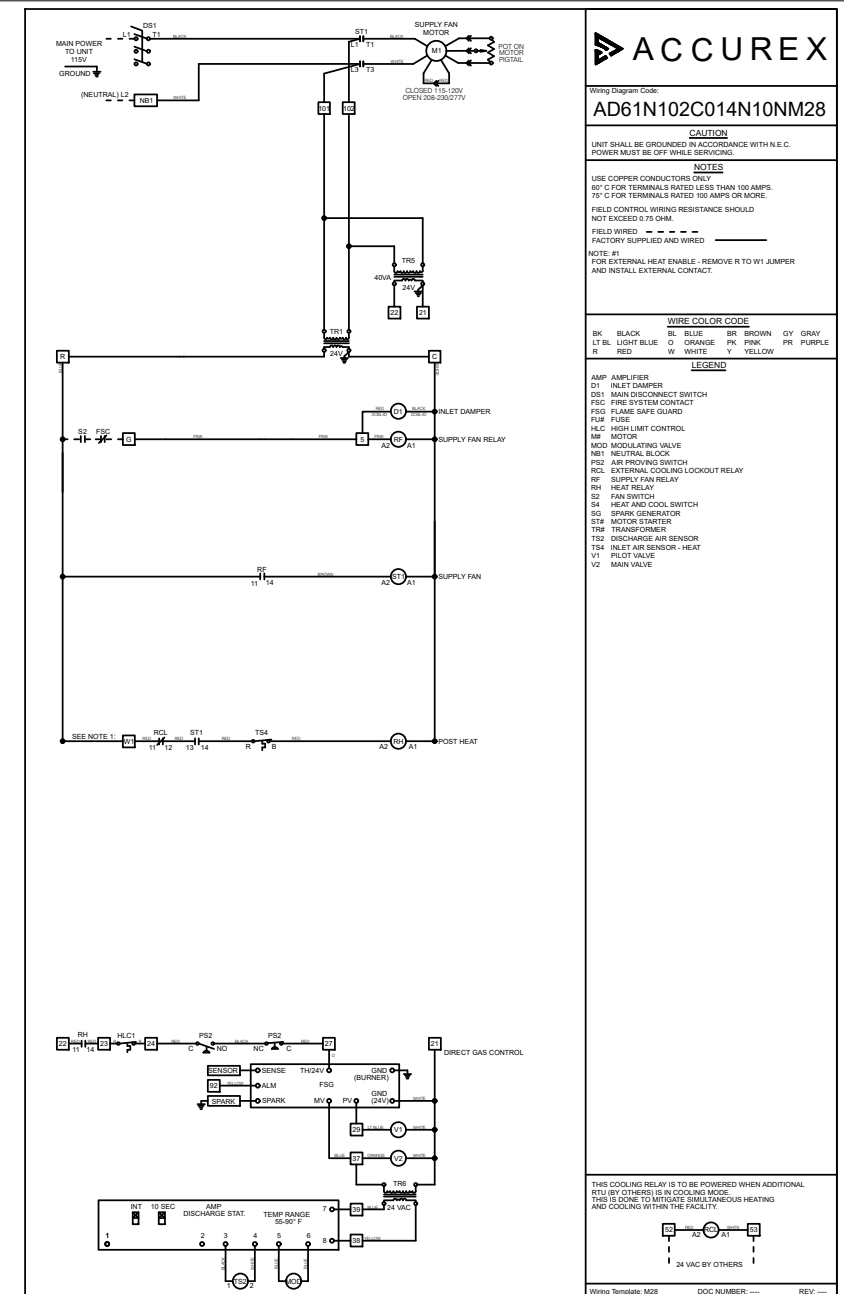

PROJECT: 10/17/2024
MARK: MAU-1

DIRECT CHAIN ACX - 2283
JOE AYUB
JOE.AYUB@ACCUREX.COM
(857)272-8727

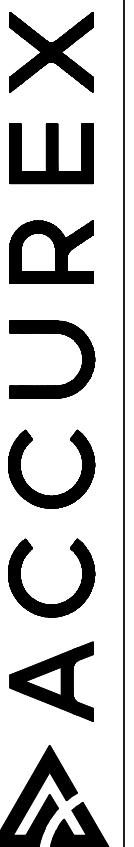

CONTROL INFORMATION

MARK	ELECTRICAL CONTROL PACKAGE		USER INTERFACE		FANS CONTROLLED											
	MODEL	LOCATION	TYPE	LOCATION	FAN #	TYPE	FAN	FAN MARK	ZONE	CFM	MOTOR HP	MOTOR VOLT	CYCLE	MOTOR PHASE	MOTOR STARTER IN PANEL	VFD IN PANEL
HOOD CONTROLS	XKC-CV-SB-11-1-1-0	RIGHT CABINET ON HOOD-1	FULL COLOR TOUCHSCREEN	CABINET - RIGHT CABINET ON HOOD-1	1	SUPPLY	S1	MAU-1	1	1300	1	115	60	1	NO	NO
					2	EXHAUST	E1	EF-1 (HOOD-1) SINGLE PHASE	1	2550	2	208	60	1	NO	NO

CONTROL FEATURES
 HOOD LIGHT CONTROL
 TEMP SENSORS (FACTORY INSTALLED) - QTY. 1
 DRY FIRE CONTACTS - QTY. 2
 LIGHTS OFF DURING FIRE
 EXHAUST MAX DURING FIRE
 SUPPLY OFF DURING FIRE
 BMS INTEGRATION - BACNET MSTP

SPECIAL DESIGN REQUESTS
 SDR #K2300291-1 - APPLIANCE CONTACTORS - 20A

DOC NUMBER: --- REV: ---

CAUTION
UNIT MUST BE GROUNDED IN ACCORDANCE WITH N.E.C. POWER MUST BE OFF WHILE SERVICING.

ATTENTION
L'APPAREIL DOIT ÊTRE MIS À LA TERRE CONFORMÉMENT AU CODE C.E. L'ALIMENTATION DOIT ÊTRE COUPÉE DURANT L'ENTRETIEN.

COMMERCIAL APPLIANCE OUTLET CENTER
ELECTRICAL RATINGS: 110-240V, 1PHASE, 50-60HZ, 15A
BASE FILE #E200616, ML FILE #E313951

THESE DRAWINGS SHALL NOT BE REMOVED FROM THIS EQUIPMENT. USE COPPER CONDUCTORS RATED TO 90°C UNLESS SPECIFIED. TORQUE CONTROL & GROUND BLOCKS TO 8 LBS. IN. TORQUE POWER LUGS/SCREWS TO COMPONENT RATINGS LISTED. TORQUE CONTROL BOARD SCREW TERMINALS TO 3.5 LBS. IN. FIELD CONTROL WIRING RESISTANCE SHOULD NOT EXCEED 0.75 OHM. SEE IOM FOR ADDITIONAL INFORMATION, OR CALL FACTORY AT 1-800-371-8858.

NE PAS RETIRER CES DESSINS DE CET ÉQUIPEMENT SAUF INDICATION CONTRAIRE. UTILISER DES CONDUCTEURS EN CUIVRE CLASSÉS 90 °C. SERRER LES BORNES EN COMMANDE ET DE MISE À LA TERRE À 8 LB-PO. SERRER LES COSSÉS/VIS D'ALIMENTATION AUX COUPLES INDICQUÉS POUR LE COMPOSANT. SERRER LES BORNES À VIS DE LA CARTE DE COMMANDE À 3.5 LB-PO. LA RÉSISTANCE DU CÂBLAGE DE COMMANDE LOCAL NE DOIT PAS DÉPASSER 0.75 OHM. POUR PLUS D'INFORMATION, CONSULTER LE MANUEL OU APPELER 1-800-371-8858.

WIRING DIAGRAM CODE: WDC#
JOB NAME: CHIPOTLE-SARATOGA 5244

MODEL: XKC-CV-SB-11-1-1-0
SERIAL NUMBER: WDSN#
MARK: HOOD CONTROLS

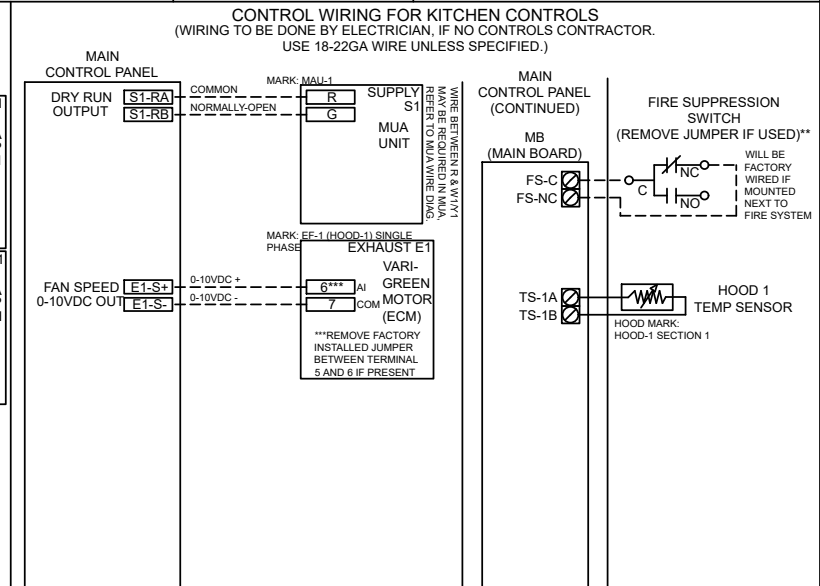
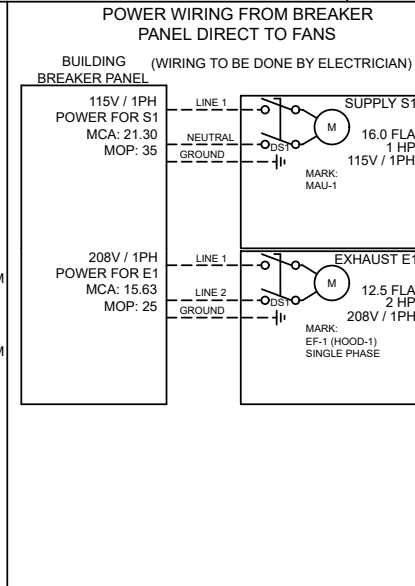
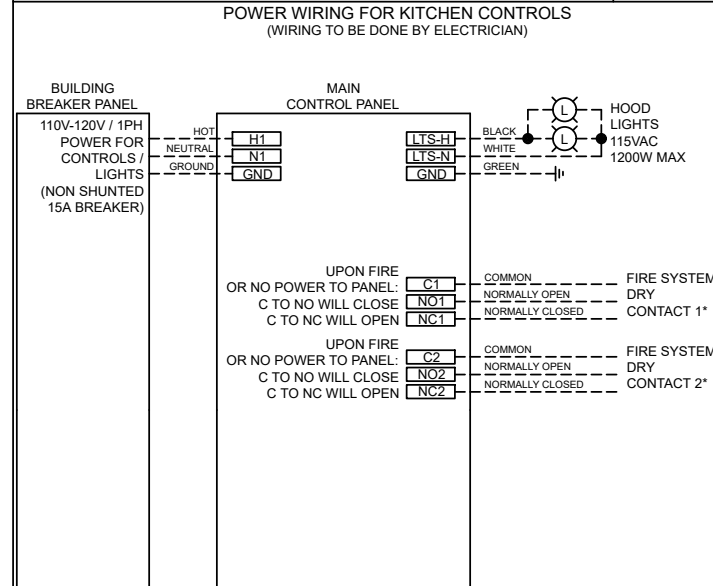

CABINET DETAILS

DRAWING NOT TO SCALE

KITCHEN HOOD

CONTROLS

USER INTERFACE DETAILS

MOUNTING TYPE
FACTORY MOUNTED:
UTILITY CABINET - RIGHT END OF HOOD

USER INTERFACE CONTROL
FANS AND LIGHTS

INTERFACE CABLE LENGTH
7FT (FACTORY PROVIDED)

MOUNTING LOCATION:
UTILITY CABINET ON HOOD
(INNER CONTROL BOX: 12 X 20 X 6)

NOTES:
1) WHEN CONTROLS ARE MOUNTED IN HOOD-MOUNTED OR WALL-MOUNTED UTILITY CABINET, FOR HOOD OR WALL CABINET DIMENSIONS SEE HOOD SUBMITTAL.
2) MINIMUM OF 36" OF CLEARANCE RECOMMENDED IN FRONT OF CONTROL CABINET

WIRING DIAGRAM CODE: WDC#

JOB NAME: CHIPOTLE-SARATOGA 5244

MODEL: XKC-CV-SB-11-1-1-0

SERIAL NUMBER: WDSN#

MARK: HOOD CONTROLS

DOC NUMBER: --- REV: ---

DEFAULT SETTINGS / PARAMÈTRES PAR DÉFAUT

FACTORY SETTINGS
TYPE: CV
CONFIGURATION: STANDARD
ZONES: 1
HOODS: 1
SUMPS: 0
EXHAUST FANS: 1
SUPPLY FANS: 1
MB ROOM SENSOR: NO
MB TEMP SENSORS: 1
HIGH TEMP FAULT: NO
FREEZE PROTECTION: YES
GAS RESET: NO
FAN PROVING: NO
BMS: BACNET MSTP

ZONE SETTINGS
SEE ZONE CONFIGURATION IN TABLE ON LEFT

HOOD SETTINGS
SEE HOOD CONFIGURATION IN TABLE ON LEFT

EXHAUST FAN SETTINGS
SEE FAN CONFIGURATION IN TABLE ON LEFT

SUPPLY FAN SETTINGS
SEE FAN CONFIGURATION IN TABLE ON LEFT

SENSOR SETTINGS
SEE HOOD CONFIGURATION IN TABLE ON LEFT

USER INTERFACE SETTINGS (MB)
FAN & LIGHT BUTTONS: SHOW BOTH (SEPERATE)

USER INTERFACE SETTINGS (HCB)
NA

GENERAL SETTINGS
TIME ZONE: CENTRAL DAYLIGHT (DEFAULT)

FIRE/FAULT SETTINGS
EXHAUST DURING FIRE: MAX
SUPPLY DURING FIRE: OFF
LIGHTS DURING FIRE: OFF

BMS SETTINGS
BAUD RATE: 9600
MAC ADDRESS: 0
MAX MASTER: 127
MAX INFO FRAMES: 20

PRG VERSION: V4

FAN CONFIGURATION												
FAN #	TYPE	FAN	FAN MARK	ZONE	MIN CFM	MAX CFM	MODBUS VFD	VFD ADDRESS	MIN FREQ.	MAX FREQ.	MIN VDC	MAX VDC
1	SUPPLY	S1	MAU-1	Z1	-	1300	NO	-	-	-	-	10.0
2	EXHAUST	E1	EF-1 (HOOD-1) SINGLE PHASE	Z1	-	2550	NO	-	-	-	-	7.7

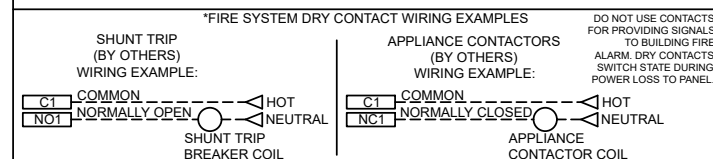

SERVICE INFORMATION

MARK: CERTIFICATION	MODEL: CERTIFICATION
ITEM: SERVICE	QUANTITY: 1

ACCUREX AFTERMARKET CERTIFICATION PROGRAM CONFIRMS THE EQUIPMENT IS INSTALLED AND OPERATING ACCORDING TO THE MANUFACTURER'S REQUIREMENTS BY A FACTORY AUTHORIZED SERVICER (FAS). INSTALLATION AND START-UP OF EQUIPMENT PER THE MANUFACTURER'S INSTALLATION AND OPERATIONS MANUAL TO BE PERFORMED BY OTHERS PRIOR TO THIS SERVICE. A WRITTEN REPORT WILL BE PROVIDED AFTER THIS SERVICE IS COMPLETED.

TRIP QUANTITY: 1

ONE TRIP TO THE JOBSITE INCLUDED FOR THE CERTIFICATION WORK TO BE PERFORMED (TIME ONSITE TBD BASED ON EQUIPMENT SELECTED)

EQUIPMENT INCLUDED IN CERTIFICATION:

- HOOD CONTROLS
- MAU-1
- EF-2 (RESTROOM)
- HOOD-1
- EF-1 (HOOD-1)

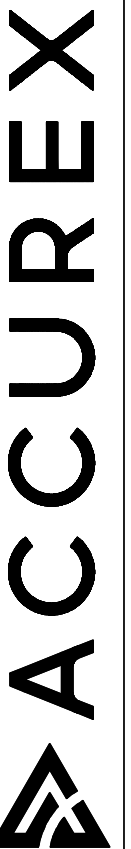

DIRECT CHAIN ACX - 2283
JOE AYUB
JOE.AYUB@ACCUREX.COM
(857)272-8727

PROJECT
10/17/2024

MARK

CHIPOTLE-SARATOGA 5244

CERTIFICATION



FIRE SYSTEM INFORMATION

MARK	MODEL	LOCATION	FLOW POINTS		SUPPLY LINE	DETECTION	MARK(S) PROTECTED BY FIRE SYSTEM
			HOODS	PCU			
FSS	ANSUL R-102 WET CHEMICAL	CABINET – RIGHT END OF HOOD-1	13 UTILIZED 22 AVAILABLE		CONTINUOUS	FUSIBLE LINK	HOOD-1 SECTION 1

FIRE SYSTEM OPTIONS AND ACCESSORIES

FULL INSTALLATION (INCLUDES PRE-PIPED HOOD(S) WITH DETECTION AND FACTORY COORDINATED INSTALL)
 CHROME SLEEVES FOR FACTORY PROVIDED APPLIANCES DROPS - INCLUDED
 METAL BLOW-OFF CAPS - INCLUDED
 GAS VALVE - INCLUDED - ELECTRICAL SHUTOFF VALVE, 1.5", 110V, 60HZ - PART# 455396
 HOOD SUPPRESSION TANK - INCLUDED - 6 GAL. - [(2) 3.0 TANK(S)]
 REMOTE PULL STATION - STANDARD - FIELD INSTALLATION AT SINGLE POINT OF EGRESS

ANSUL R102 (WET CHEMICAL) FIRE PROTECTION SYSTEM - MODEL FSSC

CONTROL PANEL

NOTES:

WET CHEMICAL FIRE PROTECTION SYSTEM TO BE ANSUL R-102, DESIGNED IN COMPLIANCE WITH UL 300 REQUIREMENTS.

- VERIFICATION OF ALL COOKING EQUIPMENT MAKE, MODEL AND LOCATION REQUIRED FOR ALL FIRE PROTECTION SYSTEMS.
- ALL FIRE SYSTEM PIPING IS STANDARDLY TO THE RIGHT END OF THE HOOD UNLESS A WALL IS LOCATED ON THE RIGHT END.
- ANSUL AUTOMAN RELEASE TO BE LOCATED WITHIN 60" OF HOOD.

THE BASIC FIRE SYSTEM WILL INCLUDE THE FOLLOWING:

- GAS SHUT-OFF VALVE, IF REQUIRED, TO BE SUPPLIED BY MANUFACTURER (UP TO 2" DIAMETER AS STANDARD), AND INSTALLED BY A LICENSED PLUMBER.
- MICRO SWITCH TO BE SUPPLIED BY MANUFACTURER FOR CONNECTION TO, BUT NOT LIMITED TO, BUILDING ALARM SYSTEM(S), EXHAUST AND SUPPLY FANS AND ELECTRICAL POWER SHUT DOWN. FIELD WIRING AND CONNECTIONS TO BE PERFORMED BY A LICENSED ELECTRICIAN.

THE BASIC FIRE SYSTEM DOES NOT INCLUDE THE FOLLOWING:

- FULL DUMP TEST OTHER THAN WHAT IS SPECIFIED PER THE INSTALLATION MANUAL, OR TO SATISFY A STATE OR LOCAL CODE. PERMIT AND TESTING FEES ARE NOT INCLUDED UNLESS NOTED UNDER THE EQUIPMENT SCHEDULE FOR THE FIRE SYSTEM.
- MORE THAN TWO TRIPS TO THE JOBSITE OR SPECIAL TRANSPORTATION, OR OVERNIGHT LODGING REQUIREMENTS IN REMOTE AREAS. NORMAL TRAVEL DISTANCE IS FIRST 50 MI. (80.5 KM) FROM OFFICE.
- SPECIAL CLASSES OR ADDITIONAL LABOR FOR ACCESS TO SECURITY SENSITIVE AREAS.
- INSTALLATION OF GAS SHUT-OFF VALVE.
- SPECIAL DRAWINGS REQUIRED TO SATISFY STATE OR LOCAL CODE. PLAN EXAMINATION FEES, PE OR FS APPROVAL STAMP.
- UNION LABOR, GOVERNMENT LABOR, OR PREVAILING WAGES REQUIRED FOR FINAL FIELD HOOK-UP.
- ANY AND ALL ELECTRICAL COMPONENTS/CONNECTIONS REQUIRED TO SHUT DOWN FANS, SHUT OFF DEVICE FOR ELECTRIC COOKING EQUIPMENT (SHUNT TRIP BREAKER), OR ACTIVATE AN ALARM SYSTEM, ETC.
- ANY DISMANTLING OR REASSEMBLY REQUIRED TO GAIN ACCESS TO THE FIRE SUPPRESSION PIPING LOCATED ON THE TOP OF THE HOOD.
- ROUGH-IN HIDDEN CONDUIT FOR REMOTE PULL STATION OR GAS VALVE (FLUSH MOUNTED PULL STATION).
- INSTALLATION OF MORE THAN (1) REMOTE PULL STATIONS OR DISTANCES GREATER THAN 20 FT (6.1M).
- PARTS OR LABOR REQUIRED TO CORRECT PIPING DUE TO COOKING EQUIPMENT CHANGES OR DEVIATION FROM PLANS. OR ANY CHARGES FOR MISSING OR ADDITIONAL PARTS OTHER THAN THOSE INDICATED ON THE FIRE SUPPRESSION DETAIL.

WIRING DIAGRAM FOR MICRO SWITCHES

NOTES:

IF ELECTRIC RELEASE, BOTH UPPER SWITCHES WILL BE USED FOR ACTUATING ADDITIONAL AUTOMANS (THEY WILL BE WIRED TO EACH OTHER AND TO THE BROWN WIRE ON THE ELECTRIC SOLENOID). THEREFORE, USE ONE OF THE UN-UTILIZED LOWER SWITCHES TO WIRE BACK TO CONTROL PANEL (DO NOT USE EITHER OF THE UPPER SWITCHES).

IF USING LOWER SWITCHES TO WIRE BACK TO CONTROL PANEL, NORMALLY-CLOSED WILL BE BLACK LEAD, AND NORMALLY-OPEN WILL BE BROWN LEAD.

DPDT SWITCHES PROVIDED BY MANUFACTURER MAY BE WIRED PER TYPICAL EXAMPLES SHOWN. VERIFY WITH LOCAL CODES AND EQUIPMENT SUPPLIED AS THE CONNECTION NEEDED FOR YOUR INSTALLATION.

CONNECTION TO BUILDINGS ALARM

CONNECTION TO KC (PCB) CONTROL PANEL

NOTES:

1. --- DENOTES FIELD INSTALLATION.
 2. ——— DENOTES FACTORY INSTALLATION.

WIRING DIAGRAM FOR MANUAL RESET RELAY (ELECTRIC GAS VALVE ONLY)

ANSUL PN 426151 (FACTORY PN 468825)

****GAS VALVES: "UL LISTED ELECTRICALLY-OPERATED SAFETY VALVE FOR NATURAL OR LP GAS AS NEEDED OF APPROPRIATE PRESSURE AND TEMPERATURE RATING, 110/600 KHZ" OR ANSUL GAS VALVES, PART NUMBERS 13707, 13708, 13709, 13710 AND 17643.**

SEE ANSUL MANUAL SECTION 5 - INSTALLATION INSTRUCTIONS FOR ADDITIONAL WIRING SCHEMATICS FOR MANUAL RESET RELAY



CHIPOTLE-SARATOGA 5244

PROJECT 10/17/2024

MARK
 DIRECT CHAIN ACX - 2283
 JOE AYOUB
 JOE.AYOUB@ACCUREX.COM
 (857)272-8727

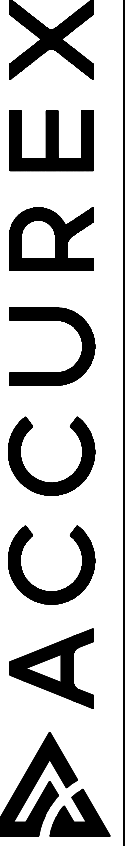

FSS

