



Submittal

Prepared For:
All Bidders

Date: June 01, 2023

Job Name:
Kroger L366 Louisville KY

Trane U.S. Inc. is pleased to provide the following submittal for your review and approval.

Product Summary

Qty Product

1 3-10 Ton R-410A PKGD Unitary Gas/Electric Rooftop (Y4C)

The attached information describes the equipment we propose to furnish for this project and is submitted for your approval.

Submittal acceptance and return is a critical step, so please ensure submittals are returned with approval to release to production within 14 days of submittal date.

Product performance and submittal data is valid for a period of 6 months from the date of submittal generation. If six months or more has elapsed between submittal generation and equipment release, the product performance and submittal data will need to be verified. It is the customer's responsibility to obtain such verification.

Coordination details:

- Roof Curb not included

Ryan Stephens on behalf of:
Jeff Betz - Trane U.S. Inc.
2300 CityGate Drive, Suite 100
Columbus, OH 43219

For questions on this project call 866-415-2499, Option #4 - - or email: kroger@trane.com

Table of Contents

Product Summary	1
3-10 Ton R-410A PKGD Unitary Gas/Electric Rooftop (Y4C) (Item A1)	3
Tag Data	3
Product Data.....	3
Performance Data.....	4
Mechanical Specifications	6
Dimensional Drawings	11
Weight, Clearance & Rigging	14
Accessory	16
Field Installed Options - Part/Order Number Summary	20
3-10 Ton R-410A PKGD Unitary Gas/Electric Rooftop	20

Tag Data - 3-10 Ton R-410A PKGD Unitary Gas/Electric Rooftop (Y4C) (Qty: 1)

Item	Tag(s)	Qty	Description	Model Number
A1	RTU-N	1	5 Ton PKGD Gas - HGRH	YHC060E3RLA**H0C1A1B6B00G000001000000000

Product Data - 3-10 Ton R-410A PKGD Unitary Gas/Electric Rooftop (Y4C)**Item: A1 Qty: 1 Tag(s): RTU-N**

DX cooling, gas heat
 High efficiency
 Convertible configuration
 5 Ton
 208-230/60/3
 Microprocessor controls
 Low gas heat
 Economizer Comparative Enthalpy 0-100% with Barometric Relief
 Hinged panels/2 in pleated filters MERV 8
 Standard condenser coil w/hail guard
 Through the base electrical
 Non-fused disconnect
 Powered convenience outlet
 BACnet Communications Interface
 Dehumidification-hot gas reheat
 Fan failure switch, discharge air sensing & Condensate Drain Pan Overflow Switch
 Human Interface
 Humidity wall mounted sensor (Field Installed)

The following items are excluded (pkg):

- If not specifically listed, extra filters, extra belts, extra sheaves, thermostat, external isolation, air balance, curb adapter, roof curb, hurricane ties downs and wind load calculations, condensate overflow switch and start up are not included. **Labor warranty to be provided by the installing contractor if not purchased.**

Performance Data - 3-10 Ton R-410A PKGD Unitary Gas/Electric Rooftop (Y4C)

Tags	RTU-N
Design Airflow (cfm)	2000
Airflow Application	Downflow
Cooling Entering DB (F)	79.00
Cooling Entering WB (F)	66.00
Ent Air Relative Humidity (%)	50.51
Ambient Temp (F)	93.00
Evap Coil Leaving Air Temp (DB) (F)	57.00
Evap Coil Leaving Air Temp (DB) (F)	57.00
Evap Coil Leaving Air Temp (WB) (F)	55.49
Evap Coil Leaving Air Temp (WB) (F)	55.49
Cooling Leaving Unit DB (F)	59.05
Cooling Leaving Unit WB (F)	56.30
Cooling LDB with reheat (F)	74.90
Gross Total Capacity (MBh)	63.44
Gross Sensible Capacity (MBh)	47.52
Gross Latent Capacity (MBh)	15.91
Net sensible heat ratio w/reheat on (Number)	0.24
Net Total Capacity (MBh)	59.82
Net Sensible Capacity (MBh)	43.90
Net Sensible Heat Ratio (Number)	0.73
Heating EAT (F)	60.00
Heating LAT (F)	82.60
Heating Delta T (F)	22.60
Input Heating Capacity (MBh)	60.00
Output Heating Capacity (MBh)	48.00
Output Heating Cap. w/Fan (MBh)	51.62
Design ESP (in H2O)	1.000
Component SP (in H2O)	0.320
Field supplied drive kit required	None
Indoor mtr operating power (bhp)	1.12
Indoor RPM (rpm)	1155
Indoor Motor Power (kW)	0.84
Outdoor Motor Power (kW)	0.38
Compressor Power (kW)	3.91
System Power (kW)	5.13
MCA (A)	26.00
MOP (A)	40.00
Compressor 1 RLA (A)	15.90
Compressor 2 RLA (A)	0.00
Evaporator fan FLA (A)	3.40
Condenser fan FLA (A)	2.50
Evaporator face area (sq ft)	9.89
Evaporator rows (Each)	4.00
Evaporator fin spacing (Per Foot)	192
Evaporator face velocity (ft/min)	202
Min. unit operating weight (lb)	748.0
Max. unit operating weight (lb)	999.0
Fan motor heat (MBh)	3.62
Reheat Temp Rise (F)	17.91
Reheat Capacity (MBh)	38.86
Dew Point (F)	54.46
Dew Point (F)	54.46
Leaving Air Humidity Ratio (lb/lb)	0.01
Moisture Removal (gal/hr) (gph)	1.80

Tags	RTU-N
Mixed Air Humidity Ratio (lb/lb)	0.01
Leaving Unit Rel Humid w/Reheat (%)	48.96
Run Acoustics	No
Ducted Discharge - 63 Hz (dB)	89
Ducted Discharge - 125 Hz (dB)	78
Ducted Discharge - 250 Hz (dB)	73
Ducted Discharge - 500 Hz (dB)	69
Ducted Discharge - 1 kHz (dB)	67
Ducted Discharge - 2 kHz (dB)	65
Ducted Discharge - 4 kHz (dB)	63
Ducted Discharge - 8 kHz (dB)	56
Ducted Inlet - 63 Hz (dB)	85
Ducted Inlet - 125 Hz (dB)	73
Ducted Inlet - 250 Hz (dB)	62
Ducted Inlet - 500 Hz (dB)	59
Ducted Inlet - 1 kHz (dB)	58
Ducted Inlet - 2 kHz (dB)	55
Ducted Inlet - 4 kHz (dB)	54
Ducted Inlet - 8 kHz (dB)	48
Outdoor Noise - 63 Hz (dB)	80
Outdoor Noise - 125 Hz (dB)	86
Outdoor Noise - 250 Hz (dB)	84
Outdoor Noise - 500 Hz (dB)	85
Outdoor Noise - 1 kHz (dB)	83
Outdoor Noise - 2 kHz (dB)	79
Outdoor Noise - 4 kHz (dB)	73
Outdoor Noise - 8 kHz (dB)	67
Rated capacity (AHRI) (MBh)	60.00
Refrig charge (HFC-410A) - ckt 1 (lb)	13.9
ASHRAE 90.1	Yes
Saturated Suction Temp Circuit 1 (F)	51.74
Saturated Discharge Temp Circuit 1 (F)	112.76
SEER/IEER @ AHRI conditions ()	14.20
EER @ AHRI Conditions ()	11.90
EER2 @ AHRI Conditions ()	11.70
SEER2 @ AHRI Conditions ()	14.70
Rated Capacity (AHRI EER2/SEER2) ()	59.00
Total Static Pressure (in H2O)	1.320
Length (ft)	7.39
Width (ft)	4.44
Height (ft)	3.41
Indoor Fan Type	FC Centrifugal
Indoor Fan Drive Type	Belt
Outdoor Fan Type	Propeller
Outdoor Fan Drive Type	Direct
Outdoor Fan Quantity ()	1
Heating Type	Gas Heat
Heating Stages	1

Mechanical Specifications - 3-10 Ton R-410A PKGD Unitary Gas/Electric Rooftop
Item: A1 Qty: 1 Tag(s): RTU-N**General**

The units shall be convertible airflow. The operating range shall be between 115°F and 0°F in cooling as standard from the factory for units with microprocessor controls. Operating range for units with electromechanical controls shall be between 115°F and 40°F. Cooling performance shall be rated in accordance with ARI testing procedures. All units shall be factory assembled, internally wired, fully charged with R-410A, and 100 percent run tested to check cooling operation, fan and blower rotation, and control sequence before leaving the factory. Wiring internal to the unit shall be colored and numbered for simplified identification. Units shall be cULus listed and labeled, classified in accordance for Central Cooling Air Conditioners.

Casing

Unit casing shall be constructed of zinc coated, heavy gauge, galvanized steel. Exterior surfaces shall be cleaned, phosphatized, and finished with a weather-resistant baked enamel finish. Unit's surface shall be tested 672 hours in a salt spray test in compliance with ASTM B117. Cabinet construction shall allow for all maintenance on one side of the unit. Service panels shall have lifting handles and be removed and reinstalled by removing two fasteners while providing a water and air tight seal. All exposed vertical panels and top covers in the indoor air section shall be insulated with a cleanable foil-faced, fire-retardant permanent, odorless glass fiber material. The base of the unit shall be insulated with 1/8", foil-faced, closed-cell insulation. All insulation edges shall be either captured or sealed. The unit's base pan shall have no penetrations within the perimeter of the curb other than the raised 1 1/8" high downflow supply/return openings to provide an added water integrity precaution, if the condensate drain backs up. The base of the unit shall have provisions for forklift and crane lifting, with forklift capabilities on three sides of the unit.

Unit Top

The top cover shall be one piece construction or, where seams exist, it shall be double-hemmed and gasket-sealed. The ribbed top adds extra strength and enhances water removal from unit top.

Two-Inch Pleated Filters

2" pleated media filters shall be available on all models.

Compressors

All units shall have direct-drive, hermetic, scroll type compressors with centrifugal type oil pumps. Motor shall be suction gas-cooled and shall have a voltage utilization range of plus or minus 10 percent of unit nameplate voltage. Internal overloads shall be provided with the scroll compressors.

Dual compressors are outstanding for humidity control, light load cooling conditions and system back-up applications. Dual compressors are available on 7½-10 ton models and allow for efficient cooling utilizing 3-stages of compressor operation for all high efficiency models.

Indoor Fan

The following units shall be equipped with a direct drive plenum fan design (T/YSC120F, T/YHC074F, T/YHC092F, T/YHC102F, 120F). Plenum fan design shall include a backward-curved fan wheel along with an external rotor direct drive variable speed indoor motor. All plenum fan designs will have a variable speed adjustment potentiometer located in the control box.

3 to 5 ton units (high efficiency 3-phase with optional motor) are belt driven, FC centrifugal fans with adjustable motor sheaves. 3 to 5 ton units (standard and high efficiency 3-phase) have multispeed, direct drive motors. All 6 to 8½ ton units (standard efficiency) shall have belt drive motors with an adjustable idler-arm assembly for quick-adjustment to fan belts and motor sheaves. All motors shall be thermally protected. All 10 tons, 6 ton (074), 7½ to 8½ (high efficiency) units have variable speed direct drive motors. All indoor fan motors meet the U.S. Energy Policy Act of 1992 (EPACT).

Outdoor Fans

The outdoor fan shall be direct-drive, statically and dynamically balanced, draw-through in the vertical discharge position. The fan motor shall be permanently lubricated and shall have built-in thermal overload protection.

Evaporator and Condenser Coils

Internally finned, 5/16" copper tubes mechanically bonded to a configured aluminum plate fin shall be standard. Evaporator coils are standard for all 3 to 10 ton standard efficiency models. Microchannel condenser coils are standard for all 3 to 10 ton standard efficiency models and 4, 5, 6, 7.5, 8.5 ton high efficiency models. The microchannel type condenser coil is not offered on the 4 and 5 ton dehumidification model. Due to flat streamlined tubes with small ports, and metallurgical tube-to-fin bond, microchannel coil has better heat transfer performance. Microchannel condenser coil can reduce system refrigerant charge by up to 50% because of smaller internal volume, which leads to better compressor reliability. Compact all-aluminum microchannel coils also help to reduce the unit weight. These all aluminum coils are recyclable. Galvanic corrosion is also minimized due to all aluminum construction. Strong aluminum brazed structure provides better fin protection. In addition, flat streamlined tubes also make microchannel coils more dust resistant and easier to clean. Coils shall be leak tested at the factory to ensure the pressure integrity. The evaporator coil and condenser coil shall be leak tested to 600 psig. The assembled unit shall be leak tested to 465 psig. The condenser coil shall have a patent pending 1+1+1 hybrid coil designed with slight gaps for ease of cleaning. A plastic, dual-sloped, removable and reversible condensate drain pan with through-the-base condensate drain is standard.

Condensate Overflow Switch

This option shall shut the unit down in the event that a clogged condensate drain line prevents proper condensate removal from the unit.

Tool-less Hail Guards

Tool-less, hail protection quality coil guards are available for condenser coil protection.

Controls

Unit shall be completely factory-wired with necessary controls and contactor pressure lugs or terminal block for power wiring. Unit shall provide an external location for mounting a fused disconnect device. A choice of microprocessor or electromechanical controls shall be available. Microprocessor controls provide for all 24V control functions. The resident control algorithms shall make all heating, cooling, and/or ventilating decisions in response to electronic signals from sensors measuring indoor and outdoor temperatures. The control algorithm maintains accurate temperature control, minimizes drift from set point, and provides better building comfort. A centralized microprocessor shall provide anti-short cycle timing and time delay between compressors to provide a higher level of machine protection. 24-volt electromechanical control circuit shall include control transformer and contactor

High Pressure Control

All units include High Pressure Cutout as standard.

Phase monitor

Phase monitor shall provide 100% protection for motors and compressors against problems caused by phase loss, phase imbalance, and phase reversal. Phase monitor is equipped with an LED that provides an ON or FAULT indicator. There are no field adjustments. The module will automatically reset from a fault condition.

BACnet Communications

The BACnet communications interface allows the unit to communicate directly with a generic open protocol BACnet MS/TP Network Building Automation System Controls.

Refrigerant Circuits

Each refrigerant circuit offer thermal expansion valve as standard. Service pressure ports, and refrigerant line filter driers are factory-installed as standard. An area shall be provided for replacement suction line driers.

Gas Heating Section

The heating section shall have a progressive tubular heat exchanger design using stainless steel burners and corrosion resistant steel throughout. An induced draft combustion blower shall be used to pull the combustion products through the firing tubes. The heater shall use a direct spark ignition (DSI) system. On initial call for heat, the combustion blower shall purge the heat exchanger for 20 seconds before ignition. After three unsuccessful ignition attempts, the entire heating system shall be locked out until manually reset at the thermostat/zone sensor. Units shall be suitable for use with natural gas or propane (field-installed kit) and also comply with the California requirement for low NOx emissions (Gas/Electric Only).

Dehumidification

The unit shall be equipped with internally finned, 5/16" copper tubes mechanically bonded to configured aluminum plate fins. The coil shall be 2 row with a minimum of 16 fins per inch. Dehumidification shall be achieved by routing hot refrigerant gas from the discharge line of the compressor through the reheat coil.

Hinged Access Doors

Sheet metal hinges are available on the Filter/Evaporator, Supply Fan/Heat, and the Compressor/Control Access Doors.

Powered or Unpowered Convenience Outlet

This is a GFCI, 120v/15amp, 2 plug, convenience outlet, either powered or unpowered. When the convenience outlet is powered, a service receptacle disconnect will be available. The convenience outlet is powered from the line side of the disconnect or circuit breaker, and therefore will not be affected by the position of the disconnect or circuit breaker. This option can only be ordered when the Through the Base Electrical with either the Disconnect Switch or Circuit Breaker option is ordered.

Economizer

This accessory shall be available with or without barometric relief. The assembly includes fully modulating 0-100 percent motor and dampers, minimum position setting, preset linkage, wiring harness with plug, spring return actuator and fixed dry bulb control. The barometric relief shall provide a pressure operated damper that shall be gravity closing and shall prohibit entrance of outside air during the equipment off cycle. Optional solid state or differential enthalpy control shall be available for either factory or field installation. The economizer arrives in the shipping position and shall be moved to the operating position by the installing contractor.

Through the Base Electrical Access

An electrical service entrance shall be provided allowing electrical access for both control and main power connections inside the curb and through the base of the unit. Option will allow for field installation of liquid-tight conduit and an external field-installed disconnect switch.

Through the Base Electrical with Disconnect Switch

This 3-pole, molded case, disconnect switch with provisions for through the base electrical connections are available. The disconnect switch will be installed in the unit in a water tight enclosure with access through a swinging door. Wiring will be provided from the switch to the unit high voltage terminal block. The switch will be UL/CSA agency recognized.

Note: The disconnect switch will be sized per NEC and UL guidelines but will not be used in place of unit overcurrent protection.

*****ATTENTION*****

For installation in SCAQMD only: This furnace does not meet the SCAQMD Rule 1111 14 ng/J NOx emission limit, and thus is subject to a mitigation fee of up to \$450. This furnace is not eligible for the Clean Air Furnace Rebate Program: www.CleanAirFurnaceRebate.com.

Control Specification (if applied in a system with a system-level controller)**A. CONTROL SYSTEM OVERVIEW:**

Control System shall include a System Controller, all controllers for HVAC equipment and ancillary devices (such as lights and exhaust fans), wireless communication between the System Controller, equipment controllers, and space sensors, and all wiring and end devices required. Control System to be fully programmed and commissioned by the installing contractor.

B. TOUCH SCREEN DISPLAY:

Control System shall include a 10" color Touch Screen Display for use by building occupants to adjust zone temperature setpoints, override lighting and HVAC equipment for after-hours use, modify schedules, and view service notifications. This display shall have PIN access for users and provide setpoint adjustment limits.

C. MOBILE APP:

Control System manufacturer shall provide a Mobile App for iOS and Android devices to allow occupants to perform the same functions (listed above) as the Touch Screen Display.

D. WEB BROWSER INTERFACE:

System Controller shall have an embedded Web Browser Interface to allow the installer and service providers to make adjustments to system control parameters and view trend logs and other service information.

E. SYSTEM CONTROLLER:

System Controller shall provide scheduling and coordination of all HVAC equipment, exhaust fans, and controlled lighting devices. The System Controller shall include a software application that coordinates the operation of rooftop units and VAV terminals. The System Controller shall support multiple system types, including Single-Zone Constant Volume, Single-Zone VAV, Changeover Bypass, Changeover VAV, and Multiple-Zone VAV with Terminal Heat (electric or hot water). The System Controller shall provide energy optimization strategies including Night Setback, Optimal Start, Fan Pressure Optimization, Discharge Air Temperature Reset, and Demand-Controlled Ventilation.

F. REMOTE ACCESS/NETWORK SECURITY:

Installer shall provide secure remote access to the Control System to enable the owner or service provider to access the system remotely using the Mobile App or Web Browser Interface. The Control System must be secured behind a firewall and not allow any inbound ports to be open or exposed to the internet. Control System manufacturer shall provide a remote access portal accessible by the owner and/or a service provider (as authorized by the owner).

Sequence of Operation (if applied in a SINGLE-ZONE CONSTANT-VOLUME SYSTEM or a CHANGEOVER BYPASS SYSTEM)**A. SYSTEM OPERATING MODES:**

The System Controller shall send the equipment controllers Occupied/Unoccupied, Morning Warm-up/Pre-cool, and Heat/Cool modes. If communication is lost, the equipment controllers shall operate using default modes and setpoints.

1. NIGHT SETBACK:

During unoccupied mode, the system shall shut off. If the zone temperature drifts to the unoccupied heating or cooling setpoint, the system shall start up to heat or cool the zone, while the OA damper remains closed (unless economizing).

2. OPTIMAL START:

The System Controller shall automatically determine the optimal start time, such that each zone reaches its occupied setpoint just in time for scheduled occupancy.

3. DEMAND-CONTROLLED VENTILATION:

For those zones equipped with an occupancy sensor or CO2 sensor, outdoor airflow shall be reset based on occupancy status and/or measured CO2 concentration.

B. SINGLE-ZONE CONSTANT-VOLUME SYSTEM**1. OCCUPIED HEAT/COOL:**

The RTU shall operate the supply fan continuously and modulate (or cycle) compressors, modulate (or stage) heat, and/or enable airside economizing to maintain zone temperature at setpoint. The OA damper shall open to bring in the required amount of ventilation.

2. MORNING WARM-UP/PRE-COOL:

The RTU shall operate the supply fan and modulate (or cycle) compressors or modulate (or stage) heat to raise/lower zone temperature to its occupied setpoint. The OA damper shall remain closed, unless economizing.

D. CHANGEOVER BYPASS SYSTEM**1. OCCUPIED HEAT/COOL:**

Each VAV terminal shall use pressure-independent control, with airflow measurement, to vary primary airflow to maintain zone temperature at its occupied setpoint. The RTU shall modulate the bypass damper to maintain duct static pressure at setpoint and modulate (or cycle) compressors, modulate (or stage) heat, and/or enable airside economizing based on current zone cooling/heating demands. The OA damper shall open to bring in the required amount of ventilation.

2. MORNING WARM-UP/PRE-COOL:

Each VAV terminal unit shall vary primary airflow to raise/lower zone temperature to its occupied setpoint. The RTU shall modulate the bypass damper to maintain duct static pressure at setpoint and modulate (or cycle) compressors or modulate (or stage) heat based on current zone cooling/heating demands. The OA damper shall remain closed, unless economizing.

3. COOLING/HEATING CHANGEOVER LOGIC:

The System Controller shall determine the overall system cooling/heating mode based on "voting" from each zone. When the majority of zones require cooling, the RTU shall operate in cooling mode and any zone that requires heating shall reduce primary airflow to minimum. When the majority of zones require heating, the RTU shall operate in heating mode and any zone that requires cooling shall reduce primary airflow to minimum.

Dimensional Drawings - 3-10 Ton R-410A PKGD Unitary Gas/Electric Rooftop
Item: A1 Qty: 1 Tag(s): RTU-N

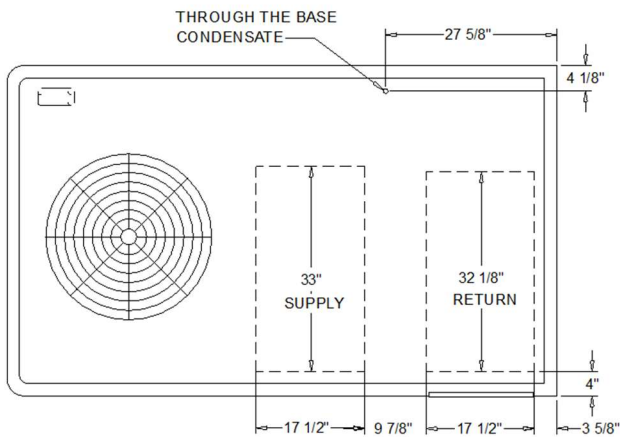
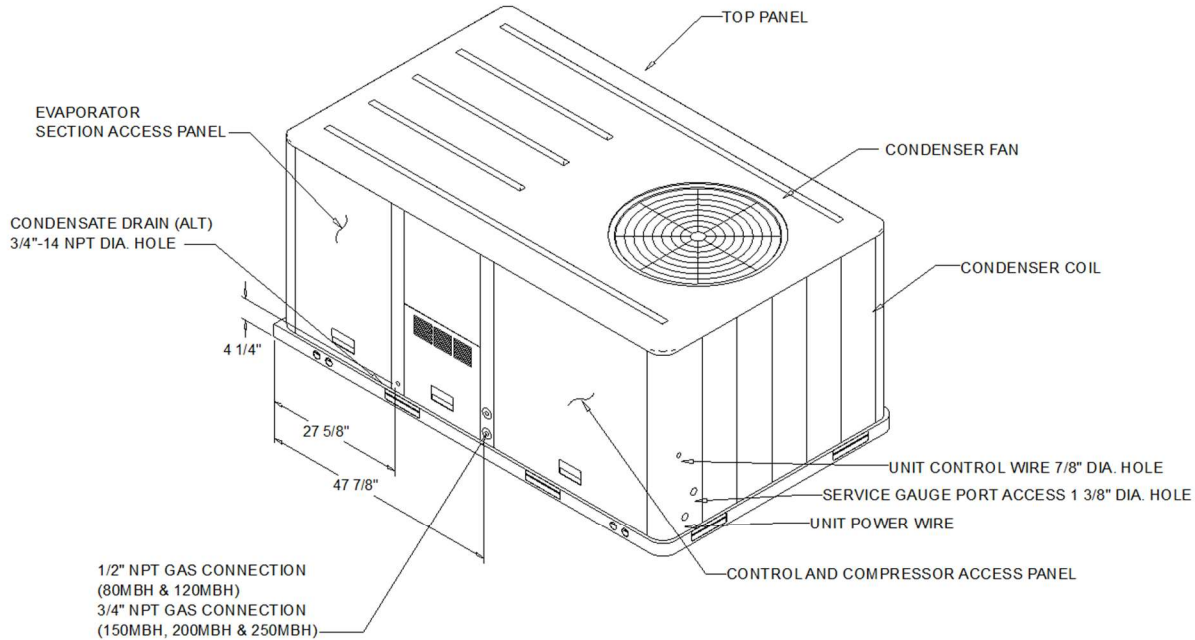

- NOTES:**
1. THRU -THE -BASE ELECTRICAL AND GAS IS NOT STANDARD ON ALL UNITS.
 2. VERIFY WEIGHT, CONNECTION, AND ALL DIMENSION WITH INSTALLER DOCUMENTS BEFORE INSTALLATION

PLAN VIEW UNIT
 DIMENSION DRAWING

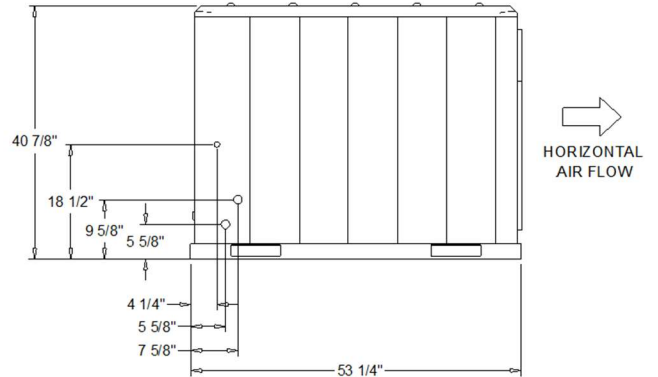
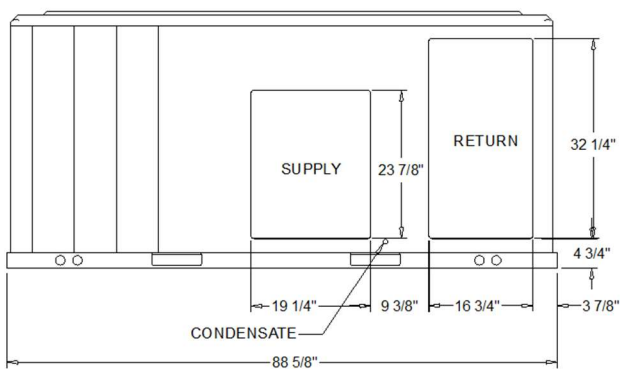

PACKAGED GAS / ELECTRICAL
 DIMENSION DRAWING

Dimensional Drawings - 3-10 Ton R-410A PKGD Unitary Gas/Electric Rooftop
Item: A1 Qty: 1 Tag(s): RTU-N

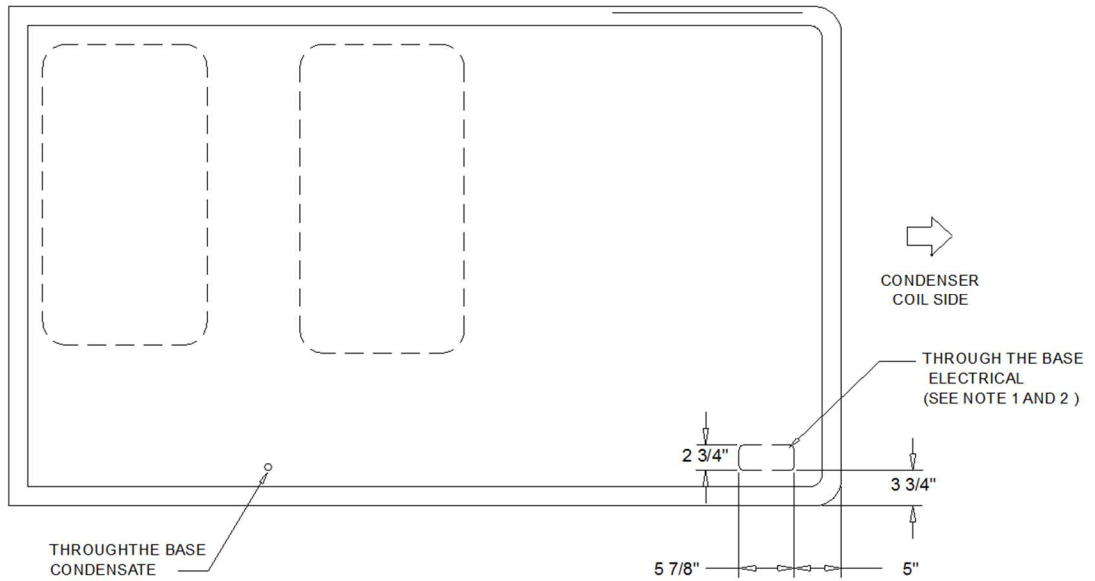
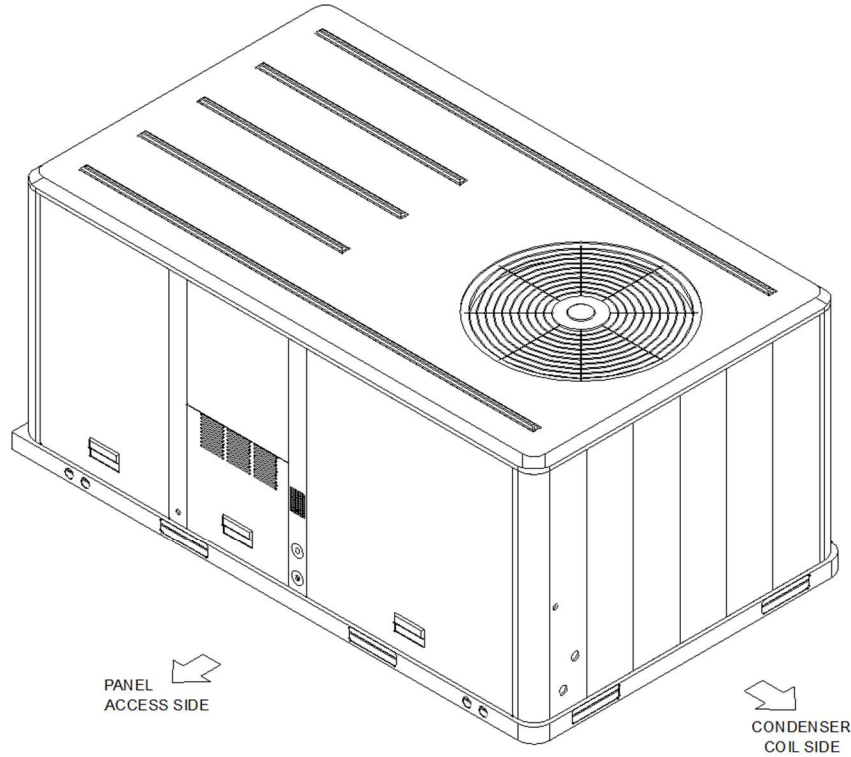

PANEL ACCESS SIDE

- NOTES:
1. THRU -THE -BASE GAS AND ELECTRICAL IS NOT STANDARD. VERIFY OPTION IN PRODUCT DATA IN THIS DOCUMENT.
 2. VERIFY WEIGHT, CONNECTION, OPTION CONFIGURATION AND ALL DIMENSION WITH INSTALLER DOCUMENTS BEFORE INSTALLATION

THRU THE BASE ELECTRICAL
PLAN / ISO VIEW DRAWING

Dimensional Drawings - 3-10 Ton R-410A PKGD Unitary Gas/Electric Rooftop
Item: A1 Qty: 1 Tag(s): RTU-N

ELECTRICAL / GENERAL DATA

GENERAL ⁽²⁾⁽⁴⁾⁽⁶⁾ Model: YHC060E Oversized Motor Unit Operating Voltage: 187-253 MCA: N/A Unit Primary Voltage: 208 MFS: N/A Unit Secondary Voltage: 230 MCB: N/A Unit Hertz: 60 Unit Phase: 3 EER/SEER Standard Motor MCA: 26.0 MCA: N/A MFS: 40.0 MFS: N/A MCB: 40.0 MCB: N/A		HEATING PERFORMANCE HEATING - GENERAL DATA Heating Model: Low Heating Input (BTU): 60000 Heating Output (BTU): 49000 No. Burners: 2 No. Stages: 1 Gas Inlet Pressure Natural Gas (Min/Max): 4 1/2"/14" LP (Min/Max): 11"/14" Gas Pipe Connection Size: 1/2"					
INDOOR MOTOR Standard Motor Number: 1 Horsepower: 1.0 Motor Speed (RPM): -- Phase: 3 Full Load Amps: 3.4 Locked Rotor Amps: --				Oversized Motor Number: Horsepower: Motor Speed (RPM): Phase: Full Load Amps: Locked Rotor Amps:		Field Installed Oversized Motor Number: N/A Horsepower: N/A Motor Speed (RPM): N/A Phase: N/A Full Load Amps: N/A Locked Rotor Amps: N/A	
COMPRESSOR Circuit 1/2 Number: 1 Horsepower: 4.3 Phase: 3 Rated Load Amps: 15.9 Locked Rotor Amps: -		OUTDOOR MOTOR Number: 1 Horsepower: 0.40 Motor Speed (RPM): 1075 Phase: 1 Full Load Amps: 2.5 --					
POWER EXHAUST ACCESSORY ^(3,7) (Field Installed Power Exhaust) Phase: N/A Horsepower: N/A Motor Speed (RPM): N/A Full Load Amps: N/A Locked Rotor Amps: N/A		FILTERS Type: Throwaway Furnished: Yes Number: 4 Recommended: 16"x25"x2"		REFRIGERANT ⁽²⁾ Type: R-410 Factory Charge Circuit #1: 15.7 lb Circuit #2: N/A			

NOTES:

1. Maximum (HACR) Circuit Breaker sizing is for installations in the United States only.
2. Refrigerant charge is an approximate value. For a more precise value, see unit nameplate and service instructions.
3. Value does not include Power Exhaust Accessory.
4. Value includes oversized motor.
5. Value does not include Power Exhaust Accessory.
6. EER is rated at AHRI conditions and in accordance with DOE test procedures.
7. Installation of this power exhaust kit will affect unit level MCA and could affect MOP sizing having a direct impact on existing field wiring and unit protection devices. The change in MCA/MOP is the sole responsibility of the field installing party. Trane will not issue new nameplates as a result of this power exhaust accessory installation. FLA of the power exhaust kit option must be added to the MCA of the unit for building supply conductor sizing determination.

Weight, Clearance & Rigging - 3-10 Ton R-410A PKGD Unitary Gas/Electric Rooftop
Item: A1 Qty: 1 Tag(s): RTU-N

INSTALLED ACCESSORIES NET WEIGHT DATA

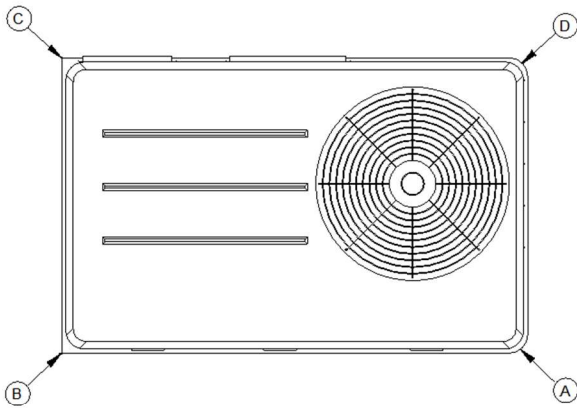

PACKAGED GAS / ELECTRICAL
CORNER WEIGHT

ACCESSORY		WEIGHTS					
ECONOMIZER		36.0 lb					
MOTORIZED OUTSIDE AIR DAMPER							
MANUAL OUTSIDE AIR DAMPER							
BAROMETRIC RELIEF							
OVERSIZED MOTOR							
BELT DRIVE MOTOR							
POWER EXHAUST							
THROUGH THE BASE ELECTRICAL/GAS (FIOPS)		13.0 lb					
UNIT MOUNTED CIRCUIT BREAKER (FIOPS)							
UNIT MOUNTED DISCONNECT (FIOPS)		5.0 lb					
POWERED CONVENIENCE OUTLET (FIOPS)		38.0 lb					
HINGED DOORS (FIOPS)		12.0 lb					
HAIL GUARD		20.0 lb					
SMOKE DETECTOR, SUPPLY / RETURN							
NOVAR CONTROL							
STAINLESS STEEL HEAT EXCHANGER							
REHEAT		14.0 lb					
ROOF CURB							
BASIC UNIT WEIGHTS		CORNER WEIGHTS		CENTER OF GRAVITY			
SHIPPING	NET	(A)	261.0 lb	(C)	156.0 lb	(E) LENGHT	(F) WIDTH
917.0 lb	822.0 lb	(B)	218.0 lb	(D)	187.0 lb	40"	22"

NOTE:

1. All weights are approximate.
2. Weights for options that are not list refer to Installation guide.
3. The actual weight are listed on the unit nameplate.
4. Refer to unit nameplate and installation guide for weights before scheduling transportation and installation of unit.
5. The weight shown represents the typical unit operating weight for the configuration selected. Estimated at +/- 10 % of the nameplate weight .
6. Verify weight, connection, and all dimension with installer documents before installation.
7. Corner weights are given for information only.
8. Net/Shipping weight of optional accessories should be added to unit weight when ordering factory or field installed accessories.

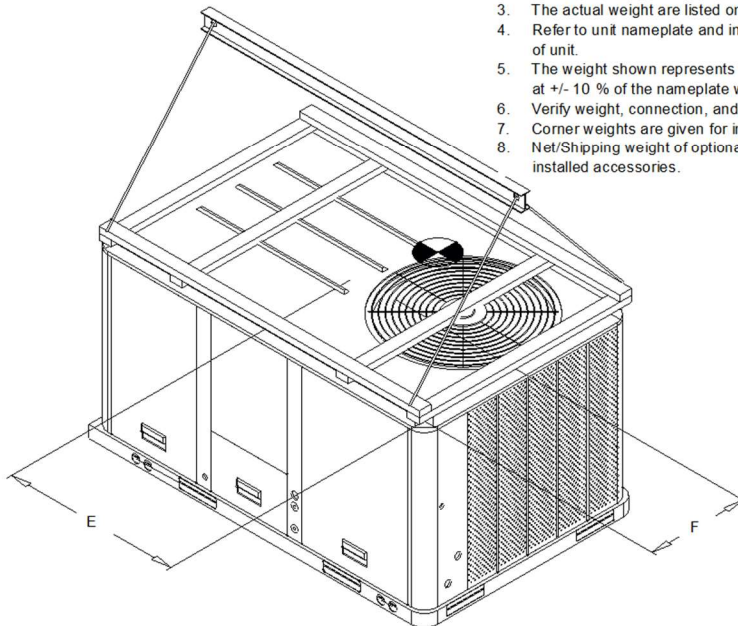

PACKAGED GAS / ELECTRICAL
RIGGING AND CENTER OF GRAVITY

Weight, Clearance & Rigging - 3-10 Ton R-410A PKGD Unitary Gas/Electric Rooftop
Item: A1 Qty: 1 Tag(s): RTU-N

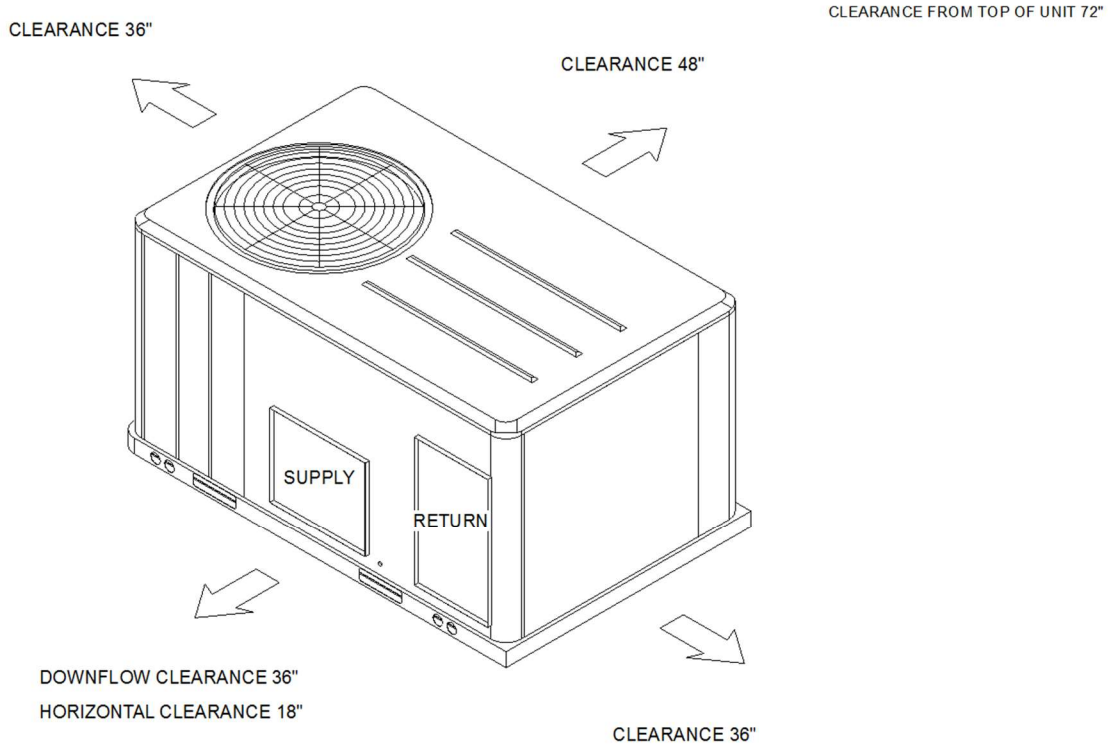

PACKAGED GAS / ELECTRIC
CLEARANCE

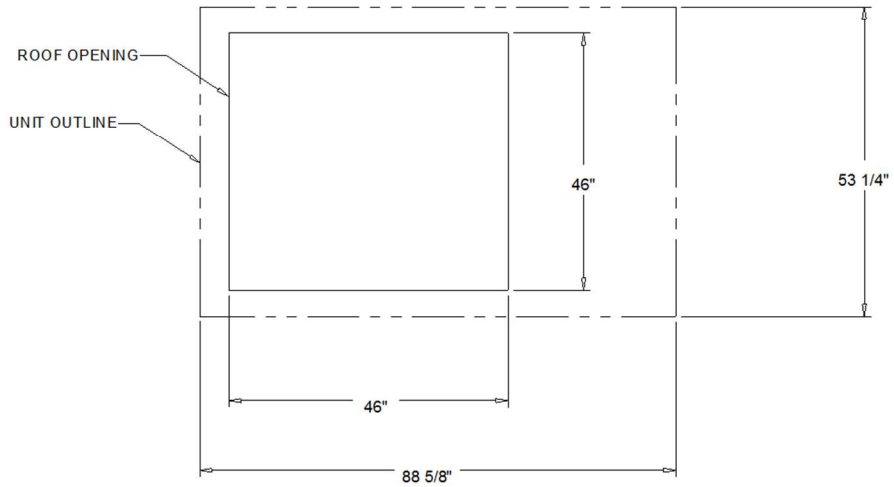

PACKAGED GAS / ELECTRIC
DOWNFLOW TYPICAL ROOF OPENING

Accessory - 3-10 Ton R-410A PKGD Unitary Gas/Electric Rooftop
Item: A1 Qty: 1 Tag(s): RTU-N

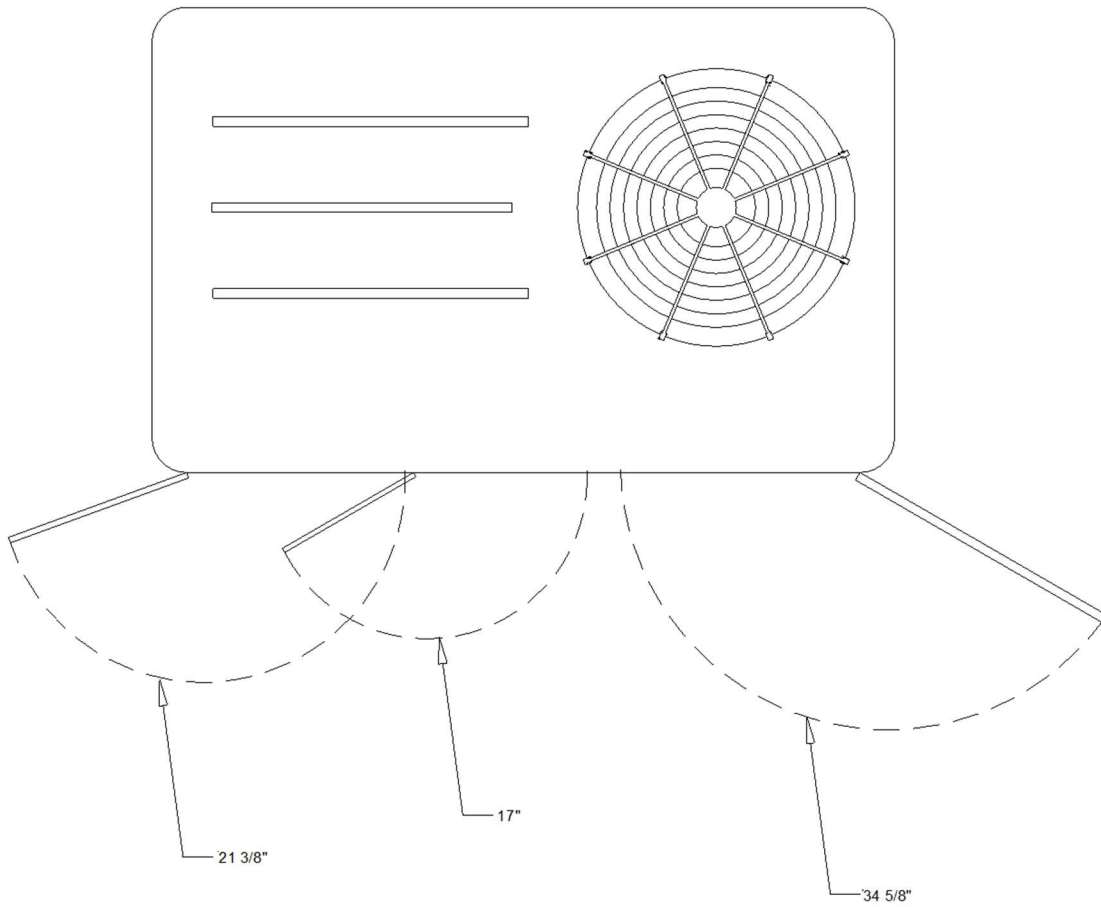

SWING DIAMETER - HINGED DOOR(S) OPTION

ACCESSORY

Accessory - 3-10 Ton R-410A PKGD Unitary Gas/Electric Rooftop
Item: A1 Qty: 1 Tag(s): RTU-N

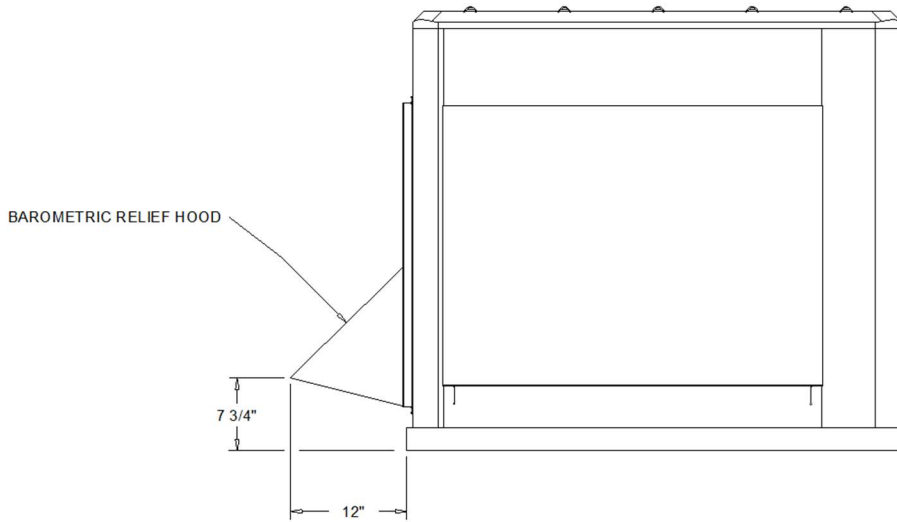
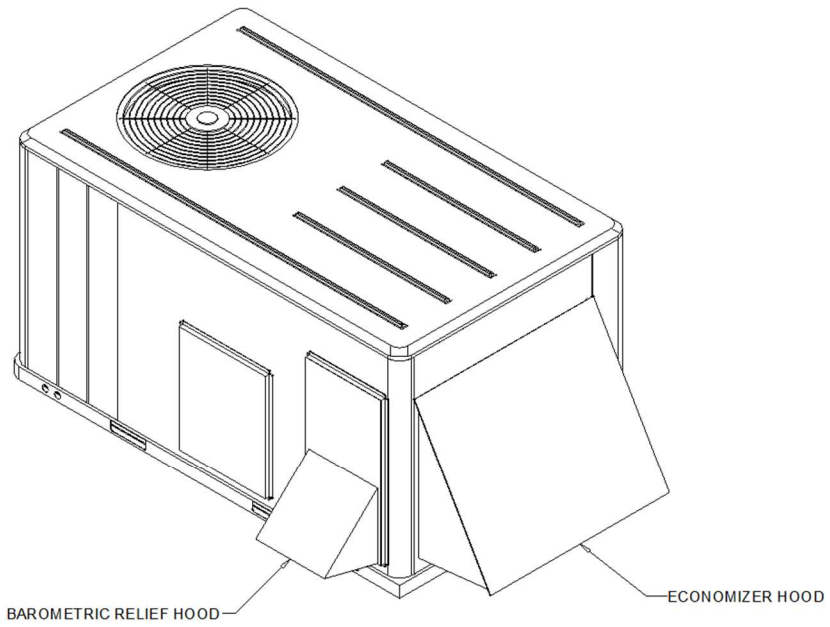

ACCESSORY - BAROMETRIC RELIEF DAMPER HOOD

Accessory - 3-10 Ton R-410A PKGD Unitary Gas/Electric Rooftop
Item: A1 Qty: 1 Tag(s): RTU-N

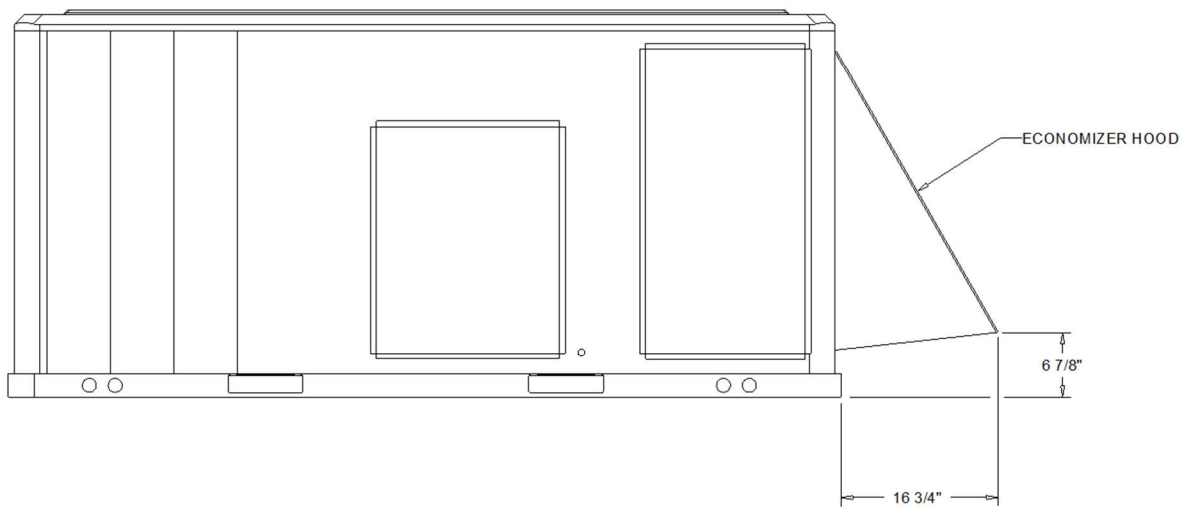
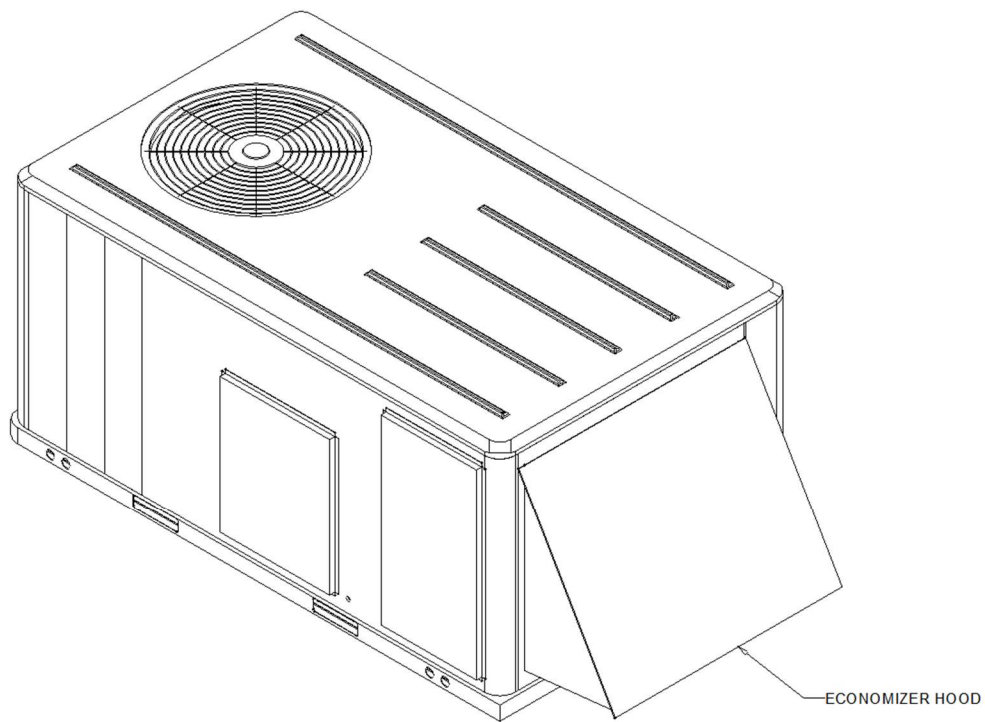

ACCESSORY - ECONOMIZER HOOD

Accessory - 3-10 Ton R-410A PKGD Unitary Gas/Electric Rooftop
Item: A1 Qty: 1 Tag(s): RTU-N

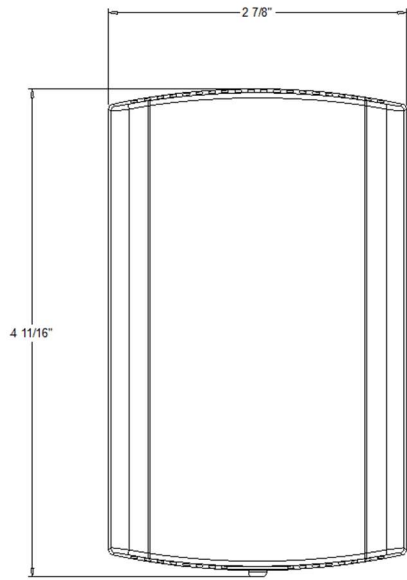

- NOTES:
1. SEE ENGINEERING SPECIFICATION FOR DETAILS.
2. VERIFY ALL DIMENSION WITH INSTALLER DOCUMENTS BEFORE INSTALLATION.

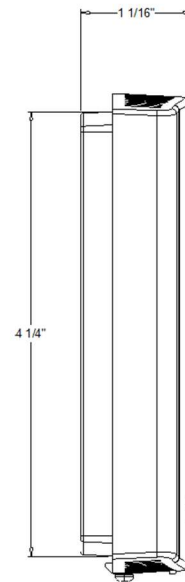
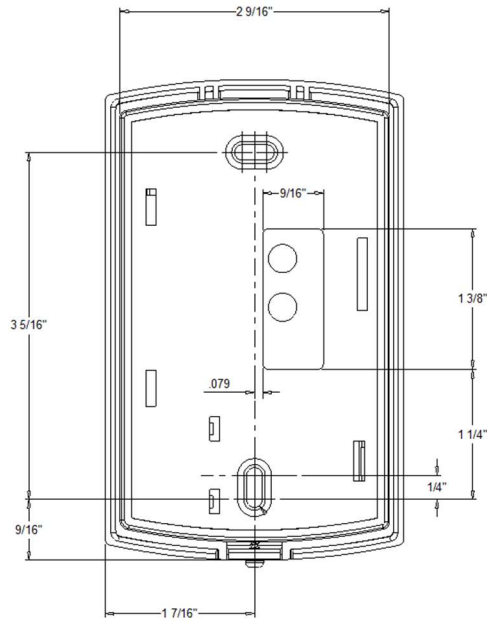

BAYSENS036A - WALL MOUNT HUMIDITY SENSOR

ACCESSORY

Field Installed Options - Part/Order Number Summary

This is a report to help you locate field installed options that arrive at the jobsite. This report provides part or order numbers for each field installed option, and references it to a specific product tag. It is NOT intended as a bill of material for the job.

Product Family - 3-10 Ton R-410A PKGD Unitary Gas/Electric Rooftop

Item	Tag(s)	Qty	Description	Model Number
A1	RTU-N	1	5 Ton PKGD Gas - HGRH	YHC060E3RLA**H0C1A1B 6B00G000001000000000

Field Installed Option Description	Part/Ordering Number
Humidity wall mounted sensor	BAYSENS036A