

Report By:

National TAB
105 Stone Village Drive
Fort Mill, SC 29708



Report: TAB REPORT
Function: Test, Adjust, & Balance
Date: 11/25/2025
Completed By: National TAB

PROJECT
JP Morgan Chase (Pittsboro,NC)

52 Harper Lane

Pittsboro, NC 27512

Client

Arnold Service Co.

820 Person St.

Fayetteville, NC 28301

National TAB

Project: JP Morgan Chase (Pittsboro,NC)

Table Of Contents

Section	Page #
Certification	3
Equipment Calibrations	4
Abbreviations	5
GRD	6
Heat Pump	10
FAN - Exhaust	28



CERTIFICATION

PROJECT: JP Morgan Chase (Pittsboro,NC)

The data presented in this report is a record of system measurements and final adjustments that have been obtained in accordance with the current edition of the NEBB *Procedural Standards for Testing, Adjusting, and Balancing of Environmental Systems*. Any variances from design quantities, which exceed NEBB tolerances, are noted in the Test-Adjust-Balance Report Project Summary.

The air distribution system has been tested and balanced and final adjustments have been made in accordance with NEBB standards and the project specifications.

NEBB TAB FIRM: National TAB-Southeast

REGISTRATION NO: 3755

CERTIFIED BY: J. Scott Springer 23312

DATE: 11/25/2025

The hydronic distribution system has been tested and balanced and final adjustments have been made in accordance with NEBB standards and the project specifications.

NEBB TAB FIRM: National TAB-Southeast

REGISTRATION NO: 3755

CERTIFIED BY: J. Scott Springer 23312

DATE:

Submitted and Certified by:

NEBB TAB FIRM: National TAB-Southeast

TAB PROFESSIONAL: J. Scott Springer

SIGNATURE: 

REGISTRATION NO: 3755 (NTAB) / 23312

CERTIFICATION EXP: 12/31/2025





National TAB



Testing, Adjusting, and Balancing Equipment

Function		Range	Minimum Accuracy	Instrument Information	Calibration Date	Date Due
AIR	AIR PRESSURE	0 in wg to 10 in wg	2% +/- 0.001 in wg	Shortridge ADM-860C S/N M19547	9/30/2025	9/30/2026
	AIR VELOCITY INSTRUMENT	50 fpm to 3900 fpm	+/- 5 % +/- 7 fpm	Shortridge ADM-860C S/N M19547	9/30/2025	9/30/2026
	DIRECT HOOD READING	100 cfm to 2000 cfm	+/- 3 % +/- 7 cfm	Evergreen Telemetry Capture Hood	8/12/2025	8/12/2026
TEMPERATURE	AIR METER	-20 F to 240 F	+/- .5 % 2 F	Cooper ATKINS - SRH77A S/N 041018026	9/30/2025	9/30/2026
	AIR PROBE	-20 F to 240 F	+/- .5 % 2 F	Cooper ATKINS - 4011 S/N 33-20	9/30/2025	9/30/2026
	IMMERSION METER	-20 F to 240 F	+/- .5 % 2 F	Cooper ATKINS - SRH77A S/N 041018026	9/30/2025	9/30/2026
	IMMERSION PROBE	-20 F to 240 F	+/- .5 % 2 F	Cooper ATKINS - 4011 S/N 33-20	9/30/2025	9/30/2026
	CONTACT METER	-20 F to 240 F	+/- .5 % 2 F	Cooper ATKINS - SRH77A S/N 041018026	9/30/2025	9/30/2026
	CONTACT PROBE	-20 F to 240 F	+/- .5 % 2 F	Cooper ATKINS - 4011 S/N 33-20	9/30/2025	9/30/2026
HUMIDITY	HUMIDITY PROBE	10 % RH to 90 % RH	3% of reading	Cooper ATKINS - SRH77A S/N 041018026	9/30/2025	9/30/2026
ELECTRICAL	VOLTAGE MEASUREMENT	0 VAC to 600 VAC	2 % reading +/- 5 digits	Dwyer CM-1 - S/N 190800099	9/30/2025	9/30/2026
	AMPERAGE MEASUREMENT	0 Amperers to 100 Amperes	2 % reading +/- 5 digits	Dwyer CM-1 - S/N 190800099	9/30/2025	9/30/2026
ROTATION	ROTATION MEASUREMENT	60 rpm to 5000 rpm	2 % reading 2 rpm	Dwyer TAC-L - S/N S1100123	9/30/2025	9/30/2026
HYDRONIC	PRESSURE MEASUREMENT	-30 in Hg to 200 psi	±2% of reading +/- 1 psi	Shortridge HDM 250 - S/N W25059	6/18/2025	6/18/2026
	DIFFERENTIAL PRESSURE MEASUREMENT	0 psi - 80 psi	±2% of reading +/- 1 psi	Shortridge HDM 250 - S/N W25059	6/18/2025	6/18/2026
DALT	DUCT LEAKAGE	-10" - +10" wc	±1% of reading +/- .0004" wc	Kanomax DALT 6900 S/N: 080439	3/7/2025	3/7/2026

Abbreviation List

A = Area (ft ²)	S.F. = Service Factor
AHU = Air Handling Unit	SF = Supply Fan
A _k = Effective Area	SP = Static Pressure
BHP = Brake Horsepower (IP) HP	SR = Supply Register
Btu = British Thermal Unit	T = Temperature
Btu/h = Btuh = BTUH = BTU/Hour	T _{ma} = Mixed Air Temperature
CL = Center Distance (used in belt formula)	T _{oa} = Outside Air Temperature
CD = Ceiling Diffuser	T _{ra} = Return Air Temperature
CF = Correction Factor	H = Head (in wc, ft wc, psi)
CFM = Volumetric Flow: Cubic Feet Per Minute	h = Enthalpy
CO ₂ = Carbon Dioxide	HP = Horsepower
CO = Carbon Monoxide	hr = Hour
C _v = Flow Constant	K _v = Flow constant (SI)
d = Diameter (in.) IP	kW = Kilowatt = 1000 Watts
Δ = Difference or Change (Final - Initial)	LAT = Leaving Air Temperature
DB = Dry Bulb	lb = Pounds
EA = Exhaust Air	LWT = Leaving Water Temperature
EAT = Entering Air Temperature	ma = Mixed Air
EF = Exhaust Fan	MIN = Minimum
Eff = Efficiency	MAX = Maximum
EG = Exhaust Grille	N/A = Not Applicable
ESP = External Static Pressure	NA = No Access
EWT = Entering Water Temperature	NL = Not Listed
°F = Degrees Fahrenheit, °F	NPSHA = Net Positive Suction Head Available
FPB = Fan Powered Box	NS = Not Specified
FLA = Full Load Amps	OA = Outside Air
fpm = Feet per Minute (fpm)	OAT = Outside Air Temperature
ft = Foot	PD = Sheave Pitch Diameter
gal = Gallons	P.D. = Pressure Drop
GPM = Gallons Per Minute (GPM)	PF = Power Factor
h = Enthalpy (BTU/lb dry air)	SG = Supply Grille
P = Pressure	SR = Supply Register
ppm = parts per million	TP = Total Pressure
psi = Pounds Per Square Inch	T _{ra} = Return Air Temperature
psid = PSI Differential	TS = Tip Speed (fpm) IP, (m/s) SI
r = Radius (in)	TSP = Total Static Pressure
% _{ra} = % of Return Air	V = Velocity
RA = Return Air	VAV = Variable Air Volume
RAT = Return Air Temperature	VD = Volume Damper
RF = Return Fan	VFD = Variable Frequency Drive
RG = Return Grille	W = Watt
RH = Relative Humidity	WB = Wet Bulb
RPM = Revolutions Per Minute	wg = wc = water gauge = water column
RTU = Roof Top Unit	WHP = Water Horsepower (IP)
SA = Supply Air	ω = Humidity Ratio



CHASE
PITTSBORO
NEW CONSTRUCTION

GENERAL NOTES

- ALL WORK SHALL COMPLY WITH 2018 NORTH CAROLINA MECHANICAL CODE WITH ALL LOCAL AMENDMENTS AND ORDINANCES; HENCEFORTH REFERRED TO AS THE NCMC.
- ALL SUPPLY, RETURN, OUTSIDE, AND EXHAUST AIR DUCTWORK INSIDE BUILDING SHALL BE WRAPPED WITH 2" INSULATION (MIN. R-6 INSTALLED). SIZES SHOWN ARE SHEET METAL DIMENSIONS.
- LAY-IN RETURN GRILLES SHALL BE EQUIPPED WITH PRICE MODEL RAC RETURN AIR CANOPY OR APPROVED EQUAL PRODUCT.
- PROVIDE PERMANENT PRINTED LABELS FOR THERMOSTATS INDICATING AREA(S) SERVED.
- CEILING SPACE IS BEING UTILIZED AS AN RA PLENUM. MATERIALS WITHIN PLENUM SPACE SHALL BE RATED FOR SUCH USE. NO PLASTIC PIPING PERMITTED IN CEILING PLENUM.
- CONTROLS FOR VRF SYSTEMS SHALL BE FURNISHED BY THE MECHANICAL CONTRACTOR. ALL OTHER HVAC EQUIPMENT SHALL BE CONTROLLED BY THE DAINTREE BMS PROVIDED BY ELECTRICAL. REFER TO ELECTRICAL DRAWINGS AND SPECIFICATIONS FOR ALL REQUIREMENTS. VRF CONTROLS SHALL TIE INTO DAINTREE FRONT END JACE PANEL.
- DAINTREE DEVICES ARE SHOWN ON MECHANICAL PLANS FOR COORDINATION PURPOSES AND TO SHOW SUGGESTED LOCATIONS. REFER TO ELECTRICAL DRAWINGS AND SPECIFICATIONS FOR ALL REQUIREMENTS.
- PROVIDE DAINTREE SUPPLY DUCT TEMPERATURE SENSOR IN ALL SUPPLY MAINS.
- AT EACH HVAC FAN MOTOR, PROVIDE DAINTREE CURRENT SENSOR WIRED TO WGA100 ADAPTER.
- PROVIDE DAINTREE OUTDOOR AIR TEMPERATURE SENSOR MOUNTED ON WALL ABOVE ELECTRIC METER/MAIN PANELS, UNLESS SHOWN OTHERWISE.
- COORDINATE EXACT HVAC SENSOR ROUGH-IN LOCATIONS IN FIELD WITH ARCHITECT/OWNER.
- TOP OF TEMPERATURE CONTROLS SHALL BE 40" A.F.F. UNLESS NOTED OTHERWISE.
- ALL AIR FLOWS SHALL BE BALANCED TO WITHIN +/- 10% OF SCHEDULED VALUES.
- PROVIDE A DUCT DETECTOR IN ALL RETURN AIR MAINS PER NCMC SECTION 606.2

KEYNOTES

- 10"x10" WRAPPED EXHAUST DUCT UP TO FAN ON ROOF.
- INDOOR UNIT SUSPENDED FROM ROOF STRUCTURE ABOVE CEILING, RE: 4M2.05 FOR DETAIL. RE: 1M2.02 FOR CONDENSATE DRAIN ROUTE.
- INDOOR UNIT MOUNTED ON WALL. RE: 1M2.02 CONDENSATE DRAIN ROUTE.
- DUCT RISE TO RUN ABOVE TRANSACTION VESTIBULE CEILING.
- BACKUP EXHAUST FAN INSTALLED INTO DATA ROOM, SUSPENDED FROM STRUCTURE ABOVE. ROUTE 12" DIA. EXHAUST DUCT THROUGH DATA ROOM WALL TO CEILING PLENUM. INSTALL 12" x 8" LOUVERED TRANSFER GRILLE IN WALL ADJACENT TO LOUNGE AS SHOWN. REFER TO BACK UP VENTILATION SYSTEM DETAIL, RE: 3M2.06.
- VRF BRANCH SELECTOR BOX, COORDINATE EXACT LOCATION IN FIELD TO MAINTAIN PROPER ACCESS.
- TRANSFER AIR DUCT TO PROVIDE RETURN AIR THROUGH UP TO DECK WALL. PROVIDE DUCTWORK IN CEILING SPACE.
- 16" x 16" WRAPPED OUTSIDE AIR DUCT UP TO INTAKE ON ROOF.
- PROVIDE REMOTE CABLE BALANCING CONTROL FOR THIS BRANCH DUCTWORK. DAMPER SHOWN FOR BRANCH SHALL BE YOUNG REGULATOR MODEL 5020CC2 OR EQUAL. PROVIDE YOUNG REGULATOR BOWDEN CABLE CONTROL SYSTEM MODEL 270-275-PH (PHILLIPS HEAD ADJUSTMENT TOOL) AND MOUNT OPERATOR ABOVE ACCESSIBLE CEILING AS SHOWN. SECURE OPERATOR TO WALL ABOVE CEILING AND PROVIDE PERMANENT LABEL FOR DAMPER DESCRIPTION.
- REMOTE CABLE CONTROL OPERATOR(S).
- OPEN END RA DUCT FOR PLENUM RETURN.
- DUCT TO RISE OVER ADJACENT HEAT PUMP UNIT.
- DUCT TO RISE AT A 45 DEGREE ANGLE.
- DUCT TO DROP AT A 45 DEGREE ANGLE.
- DUCT TO TURN AT A 90 DEGREE ANGLE TO AVOID BEAM.

1 HVAC FLOOR PLAN
1/4" = 1'-0"

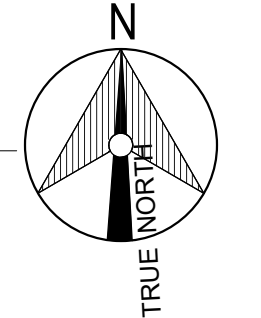
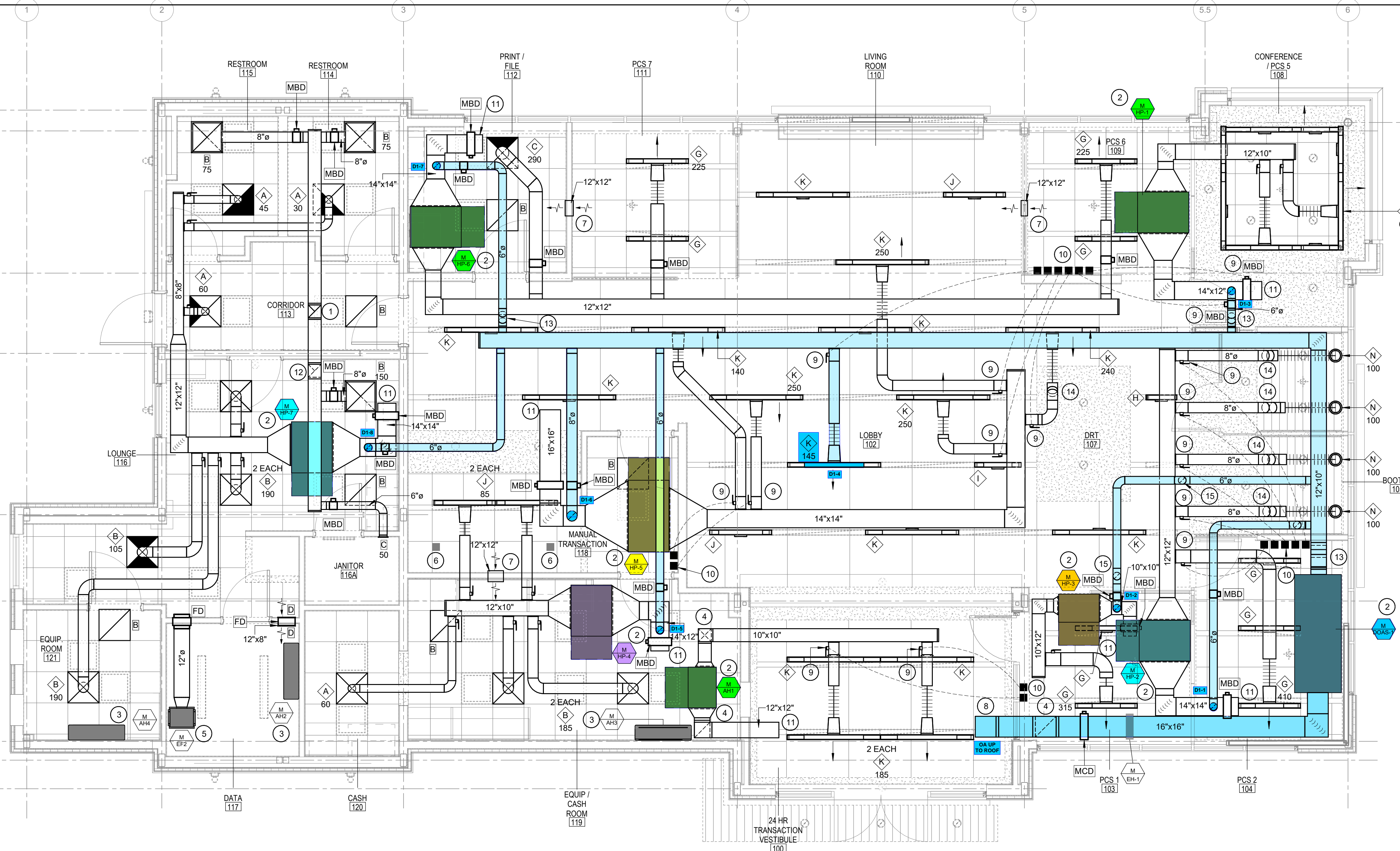

3 HVAC SYMBOL SCHEDULE

	MECHANICAL EQUIPMENT DESIGNATION AHU, REFER TO MECHANICAL EQUIPMENT TYPES SCHEDULE		WALL-MOUNTED THERMOSTAT		TYPE "B" EXH GR. BALANCE TO CFM INDICATED, SEE EQUIPMENT SCHEDULE, OTHERS SIMILAR		REFRIGERANT SUCTION
	LINEAR SLOT CEILING DIFFUSER TYPE "K", BALANCE TO 200 CFM. SLOT DIFFUSER TAGS WITHOUT A CFM LISTED INDICATE DIFFUSER IS BEING UTILIZED FOR RETURN. FURNISH WITH FBRI RETURN HOOD, REFER TO MECHANICAL SCHEDULES FOR SIZE AND CONFIGURATION		WALL-MOUNTED REMOTE TEMPERATURE SENSOR		TYPE "B" CEILING DIFFUSER (4 WAY THROW UNLESS NOTED OTHERWISE BY SHADING.) BALANCE TO 200 CFM, SEE EQUIPMENT SCHEDULE, OTHERS SIMILAR.		VERIFY ON JOB
RA	RETURN AIR		WALL-MOUNTED REMOTE HUMIDITY SENSOR		DUCT TURNING VANE		DUCT STATIC PRESSURE SENSOR FOR VRF SYSTEM BY MECHANICAL.
SA	SUPPLY AIR		DAINTREE WALL TIMER TO CONTROL EXHAUST FAN, RE: ELECTRICAL		6"x6" RECTANGULAR DUCT		FIRE DAMPER. COORDINATE RATING WITH WALL TYPE.
EXH	EXHAUST AIR		IN-DUCT SMOKE DETECTOR TEST KEY SWITCHES BY MECHANICAL, HARDWIRE TO DETECTOR		12" DIAMETER ROUND DUCT		CLEANOUT
OA	OUTSIDE AIR		REFERENCE TO MECHANICAL KEYNOTE NUMBER 1.		MANUAL BALANCING DAMPER (MBD)		
		RE: 2M2.01	REFER TO DETAIL 2, SHEET M2.01		MOTORIZED CONTROL DAMPER (MCD)		
			RETURN AIR GRILLE IN CEILING, SEE EQUIPMENT SCHEDULE, OTHERS SIMILAR.		REFRIGERANT LIQUID		

5/20/2024 5:15:09 PM

M3.01

5/20/2024 5:15:09 PM

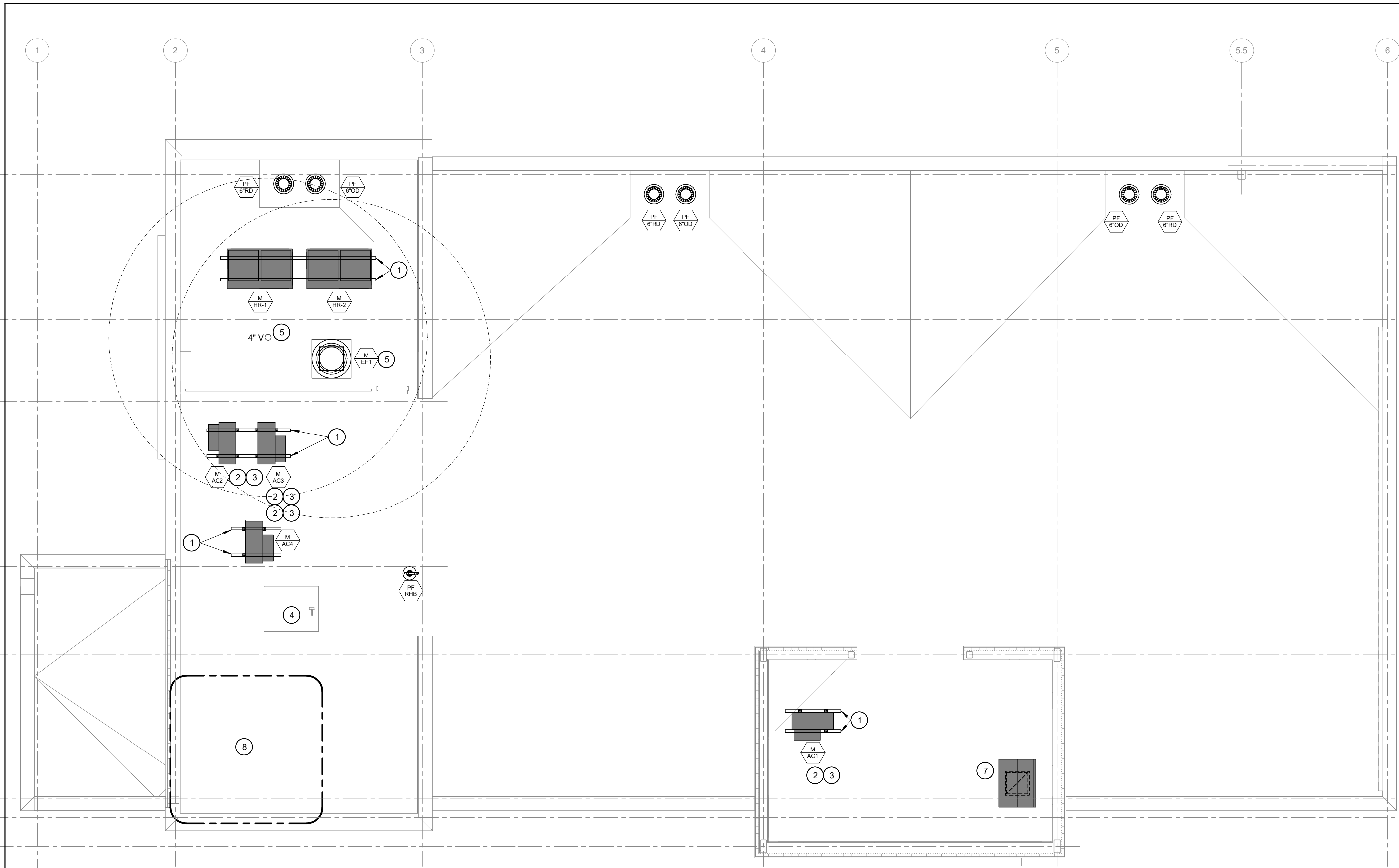

1 HVAC ROOF PLAN
M3.01 1/4" = 1'-0"

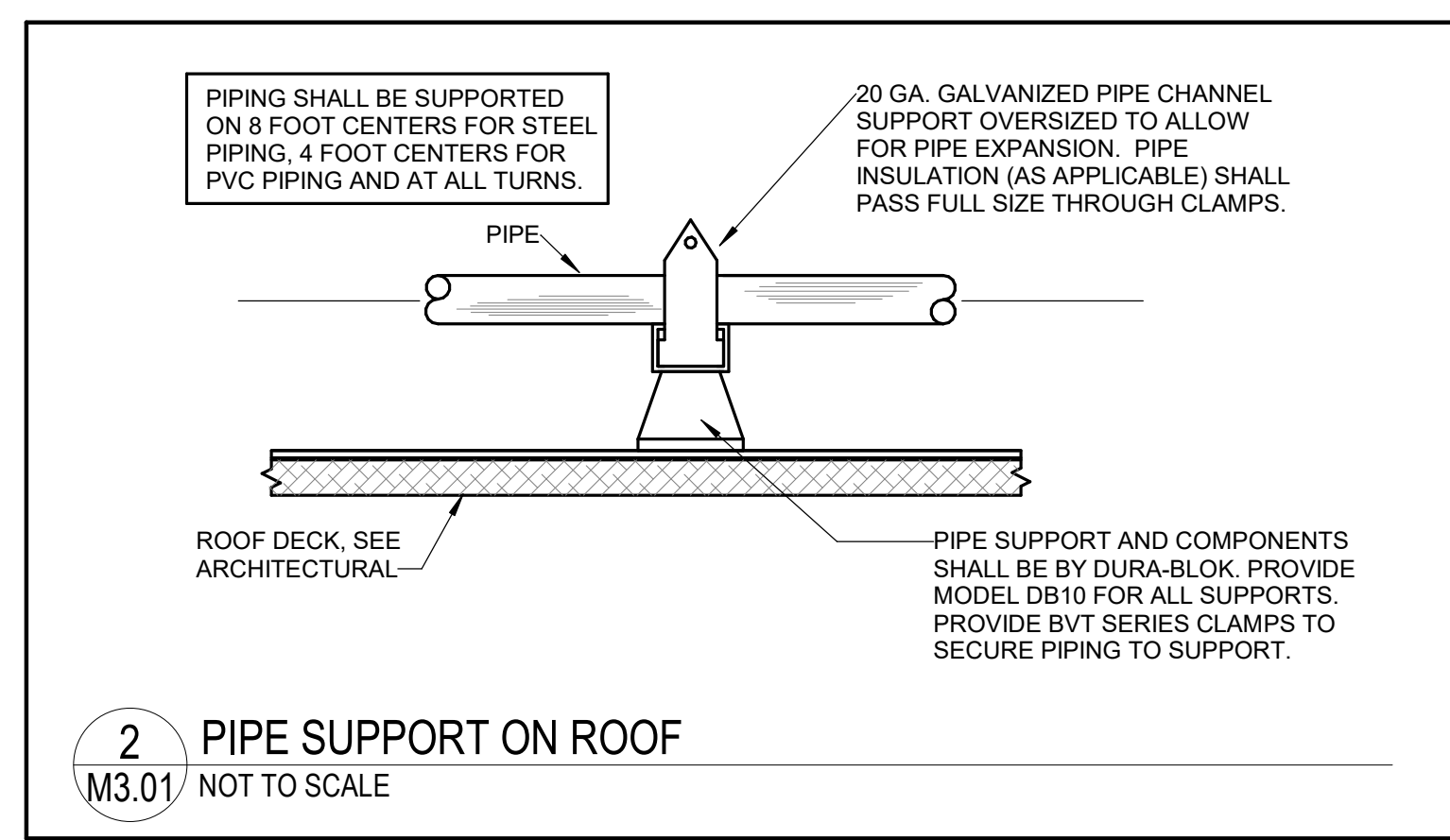
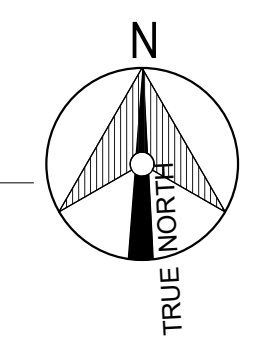

GENERAL NOTES

- CONTRACTOR SHALL COORDINATE ALL EQUIPMENT DIMENSIONS WITH BUILDING STRUCTURE PRIOR TO FABRICATING DUCTWORK. CONTRACTOR SHALL NOTIFY ARCHITECT AND ENGINEER REGARDING ANY DISCREPANCIES/CONFLICTS THAT WILL INCUR ADDITIONAL COSTS PRIOR TO CONTINUING WORK.
- COORDINATE EXACT ROOF DRAIN LOCATIONS WITH ARCHITECTURAL AND STRUCTURAL DRAWINGS.
- PIPING INSULATION FOR REFRIGERANT LINES EXPOSED ON ROOF SHALL BE PROTECTED WITH A LAYER OF POLYGLUARD ALUMAGUARD OR OTHER APPROVED JACKETING. JACKETING SHALL BE APPLIED WITHIN 72 HOURS OF PIPING INSTALLATION TO PREVENT PERMANENT UV DAMAGE TO INSULATION.
- REFER TO ARCHITECTURAL DRAWINGS FOR APPROVED ROOF PENETRATION METHODS AND MATERIALS.
- ACCESS TO EQUIPMENT SHALL BE MAINTAINED TO MEET MANUFACTURER AND CODE REQUIREMENTS.
- ALL ROOFTOP EQUIPMENT SHALL BE ANCHORED PER NCMC 301.15 AND 2018 NORTH CAROLINA BUILDING CODE 1609.1 TO MEET WIND RATING OF 125 MPH.
- CONTROLS WIRING FROM OUTDOOR UNITS TO INDOOR UNITS SHALL BE INSTALLED IN CONDUIT.

KEYNOTES

- RE: 1M2.05 FOR SUPPORT RAIL DETAIL.
- PROVIDE PIPE SUPPORTS FOR ALL EXPOSED REFRIGERANT LINES, CONDENSATE DRAINS, CONDUITS, ETC. RE: 2M3.01.
- ROUTE REFRIGERANT LINES AND CONTROLS CONDUITS TO INDOOR UNITS. RE: ARCH DRAWINGS FOR APPROVED ROOF PENETRATION METHODS.
- ROOF ACCESS HATCH (BY OTHERS). MAINTAIN REQUIRED CLEARANCES.
- LOCATE EXHAUST FAN AND VENT NO LESS THAN 10'-0" FROM FRESH AIR INTAKES.
- FOR UNIT CONTROLS, PROVIDE FAN PROOF CT WIRED, VIA LOW VOLTAGE, TO DAINTREE ADAPTER. PROVIDE SUPPLY DUCT PROBE TEMPERATURE SENSOR FOR UNIT AND CONNECT TO DAINTREE ADAPTER.
- OA INTAKE SHALL BE GREENHECK FGI SERIES, NOMINAL 36"x28" OVERALL SIZE WITH 18"x18" THROAT. INTAKE AND CURB SHALL BE HIGH WIND RATED FOR 125 MPH. PROVIDE 16" TALL ROOF CURB. INTAKE BASE HEIGHT SHALL BE 5". PROVIDE ALUMINUM BIRD SCREEN, "PERMATECTOR" COATING ON INTAKE AND CURB (COLOR BY ARCHITECT), FOAM APPLIED CURB SEAL, 1" FACTORY HOOD INSULATION, AND TIE DOWN POINTS. CURB SHALL BE INSULATED, DOUBLE-WALL WITH NO EXPOSED INSULATED MATERIAL.
- AREA ABOVE DATA ROOM SHALL BE FREE OF MECHANICAL EQUIPMENT AND THERE SHALL BE NO ROOFTOP PENETRATIONS ABOVE THIS AREA.



320 N. Carrollton Avenue, Suite 100
New Orleans, Louisiana 70119
t. 504.488.7739 f. 504.488.7743

www.VergesRome.com
© copyright 2021



CHASE
PITTSBORO
NEW CONSTRUCTION

DATE ISSUED: 20 MAY 2024
REVISED:
REVISED:
REVISED:
REVISED:
REVISED:

DRAWN BY: MEP
CHECKED BY: JHF
PHASE:

100% CD

23078

TITLE:
MECHANICAL ROOF PLAN

SHEET:

M3.01

AST ENGINEERS
8417 Kelwood Avenue
Baton Rouge, Louisiana 70806
(p) 225.926.5600 | (f) 225.926.5620
www.astengineers.us

PITTSBORO, NC 27512

52 HARPER LANE





CHASE
PITTSBORO
NEW CONSTRUCTION

GENERAL NOTES

- ALL WORK SHALL COMPLY WITH 2018 NORTH CAROLINA MECHANICAL CODE WITH ALL LOCAL AMENDMENTS AND ORDINANCES; HENCEFORTH REFERRED TO AS THE NCMC.
- ALL SUPPLY, RETURN, OUTSIDE, AND EXHAUST AIR DUCTWORK INSIDE BUILDING SHALL BE WRAPPED WITH 2" INSULATION (MIN. R-6 INSTALLED). SIZES SHOWN ARE SHEET METAL DIMENSIONS.
- LAY-IN RETURN GRILLES SHALL BE EQUIPPED WITH PRICE MODEL RAC RETURN AIR CANOPY OR APPROVED EQUAL PRODUCT.
- PROVIDE PERMANENT PRINTED LABELS FOR THERMOSTATS INDICATING AREA(S) SERVED.
- CEILING SPACE IS BEING UTILIZED AS AN RA PLENUM. MATERIALS WITHIN PLENUM SPACE SHALL BE RATED FOR SUCH USE. NO PLASTIC PIPING PERMITTED IN CEILING PLENUM.
- CONTROLS FOR VRF SYSTEMS SHALL BE FURNISHED BY THE MECHANICAL CONTRACTOR. ALL OTHER HVAC EQUIPMENT SHALL BE CONTROLLED BY THE DAINTREE BMS PROVIDED BY ELECTRICAL. REFER TO ELECTRICAL DRAWINGS AND SPECIFICATIONS FOR ALL REQUIREMENTS. VRF CONTROLS SHALL TIE INTO DAINTREE FRONT END JACE PANEL.
- DAINTREE DEVICES ARE SHOWN ON MECHANICAL PLANS FOR COORDINATION PURPOSES AND TO SHOW SUGGESTED LOCATIONS. REFER TO ELECTRICAL DRAWINGS AND SPECIFICATIONS FOR ALL REQUIREMENTS.
- PROVIDE DAINTREE SUPPLY DUCT TEMPERATURE SENSOR IN ALL SUPPLY MAINS.
- AT EACH HVAC FAN MOTOR, PROVIDE DAINTREE CURRENT SENSOR WIRED TO WGA100 ADAPTER.
- PROVIDE DAINTREE OUTDOOR AIR TEMPERATURE SENSOR MOUNTED ON WALL ABOVE ELECTRIC METER/MAIN PANELS, UNLESS SHOWN OTHERWISE.
- COORDINATE EXACT HVAC SENSOR ROUGH-IN LOCATIONS IN FIELD WITH ARCHITECT/OWNER.
- TOP OF TEMPERATURE CONTROLS SHALL BE 40" A.F.F. UNLESS NOTED OTHERWISE.
- ALL AIR FLOWS SHALL BE BALANCED TO WITHIN +/- 10% OF SCHEDULED VALUES.
- PROVIDE A DUCT DETECTOR IN ALL RETURN AIR MAINS PER NCMC SECTION 606.2

KEYNOTES

- 10"x10" WRAPPED EXHAUST DUCT UP TO FAN ON ROOF.
- INDOOR UNIT SUSPENDED FROM ROOF STRUCTURE ABOVE CEILING, RE: 4M2.05 FOR DETAIL. RE: 1M2.02 FOR CONDENSATE DRAIN ROUTE.
- INDOOR UNIT MOUNTED ON WALL. RE: 1M2.02 CONDENSATE DRAIN ROUTE.
- DUCT RISE TO RUN ABOVE TRANSACTION VESTIBULE CEILING.
- BACKUP EXHAUST FAN INSTALLED INTO DATA ROOM, SUSPENDED FROM STRUCTURE ABOVE. ROUTE 12" DIA. EXHAUST DUCT THROUGH DATA ROOM WALL TO CEILING PLENUM. INSTALL 12" x 8" LOUVERED TRANSFER GRILLE IN WALL ADJACENT TO INTAKE AS SHOWN. REFER TO BACK UP VENTILATION SYSTEM DETAIL, RE: 3M2.06.
- VRF BRANCH SELECTOR BOX, COORDINATE EXACT LOCATION IN FIELD TO MAINTAIN PROPER ACCESS.
- TRANSFER AIR DUCT TO PROVIDE RETURN AIR THROUGH UP TO DECK WALL. PROVIDE DUCTWORK IN CEILING SPACE.
- 16" x 16" WRAPPED OUTSIDE AIR DUCT UP TO INTAKE ON ROOF.
- PROVIDE REMOTE CABLE BALANCING CONTROL FOR THIS BRANCH DUCTWORK. DAMPER SHOWN FOR BRANCH SHALL BE YOUNG REGULATOR MODEL 5020CC2 OR EQUAL. PROVIDE YOUNG REGULATOR BOWDEN CABLE CONTROL SYSTEM MODEL 270-275-PH (PHILLIPS HEAD ADJUSTMENT TOOL) AND MOUNT OPERATOR ABOVE ACCESSIBLE CEILING AS SHOWN. SECURE OPERATOR TO WALL ABOVE CEILING AND PROVIDE PERMANENT LABEL FOR DAMPER DESCRIPTION.
- REMOTE CABLE CONTROL OPERATOR(S).
- OPEN END RA DUCT FOR PLENUM RETURN.
- DUCT TO RISE OVER ADJACENT HEAT PUMP UNIT.
- DUCT TO RISE AT A 45 DEGREE ANGLE.
- DUCT TO DROP AT A 45 DEGREE ANGLE.
- DUCT TO TURN AT A 90 DEGREE ANGLE TO AVOID BEAM.

1 HVAC FLOOR PLAN
1/4" = 1'-0"

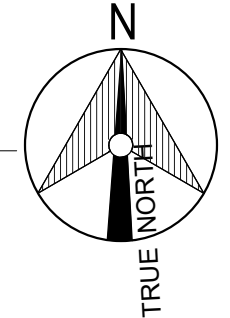
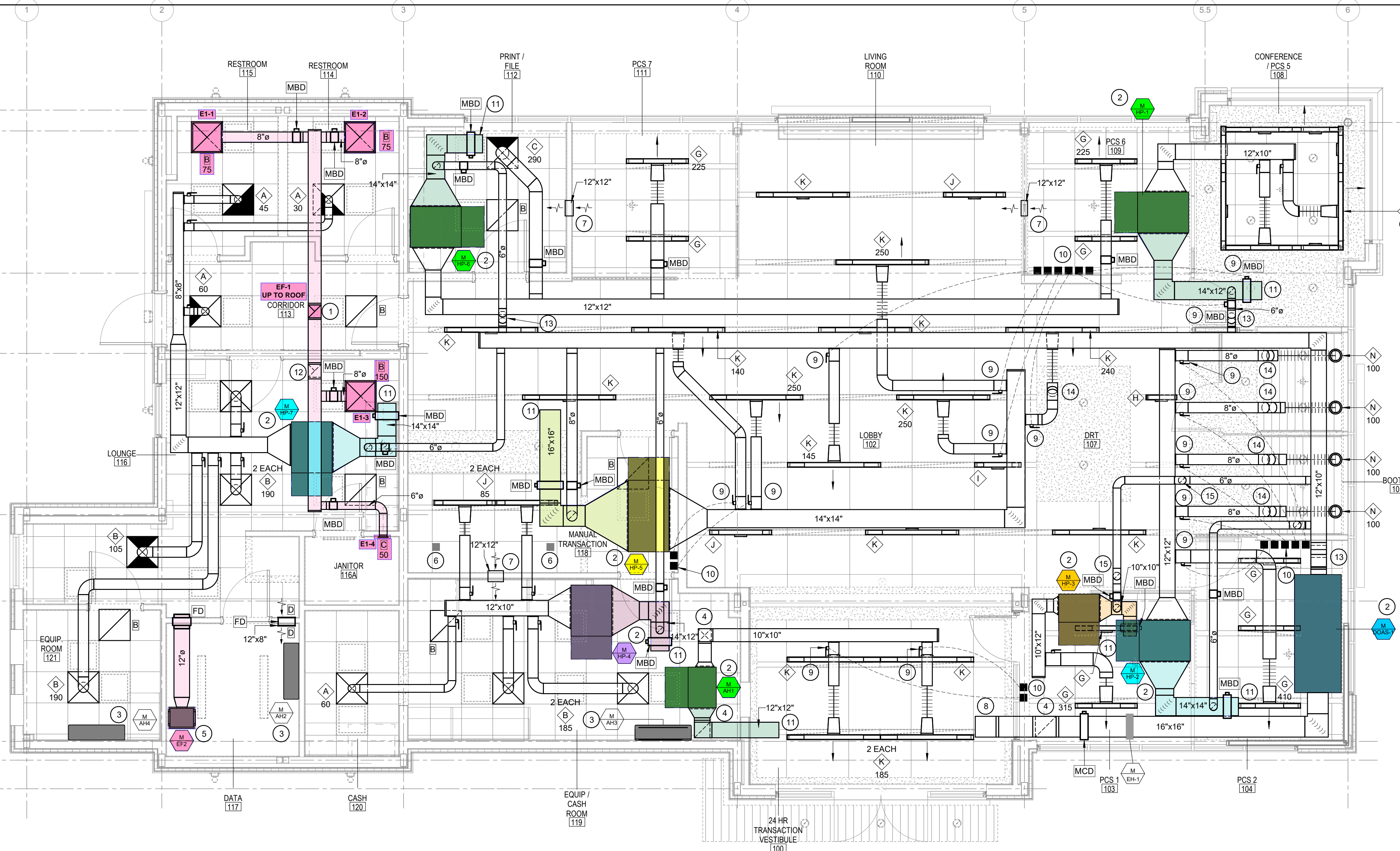

3 HVAC SYMBOL SCHEDULE

M AHU	MECHANICAL EQUIPMENT DESIGNATION AHU. REFER TO MECHANICAL EQUIPMENT TYPES SCHEDULE	T	WALL-MOUNTED THERMOSTAT	B 300	TYPE "B" EXH GR. BALANCE TO CFM INDICATED. SEE EQUIPMENT SCHEDULE, OTHERS SIMILAR	RS	REFRIGERANT SUCTION
K 200	LINEAR SLOT CEILING DIFFUSER TYPE "K". BALANCE TO 200 CFM. SLOT DIFFUSER TAGS WITHOUT A CFM LISTED INDICATE DIFFUSER IS BEING UTILIZED FOR RETURN. FURNISH WITH FBRI RETURN HOOD. REFER TO MECHANICAL SCHEDULES FOR SIZE AND CONFIGURATION	TS	WALL-MOUNTED REMOTE TEMPERATURE SENSOR	B 200	TYPE "B" CEILING DIFFUSER (4 WAY THROW UNLESS NOTED OTHERWISE BY SHADING.) BALANCE TO 200 CFM. SEE EQUIPMENT SCHEDULE, OTHERS SIMILAR.	VOJ	VERIFY ON JOB
RA	RETURN AIR	H	WALL-MOUNTED REMOTE HUMIDITY SENSOR	T	DUCT TURNING VANE	SP	DUCT STATIC PRESSURE SENSOR FOR VRF SYSTEM BY MECHANICAL.
SA	SUPPLY AIR	TIMER	DAINTREE WALL TIMER TO CONTROL EXHAUST FAN, RE: ELECTRICAL	6x6 OR 6x6	6"x6" RECTANGULAR DUCT	FD	FIRE DAMPER. COORDINATE RATING WITH WALL TYPE.
EXH	EXHAUST AIR	TEST	IN-DUCT SMOKE DETECTOR TEST KEY SWITCHES BY MECHANICAL, HARDWIRE TO DETECTOR	12" OR 12"	12" DIAMETER ROUND DUCT	CO	CLEANOUT
OA	OUTSIDE AIR	1	REFERENCE TO MECHANICAL KEYNOTE NUMBER 1.	MBD	MANUAL BALANCING DAMPER (MBD)		
		RE: 2M2.01	REFER TO DETAIL 2, SHEET M2.01	MCD	MOTORIZED CONTROL DAMPER (MCD)		
		B	RETURN AIR GRILLE IN CEILING. SEE EQUIPMENT SCHEDULE, OTHERS SIMILAR.	RL	REFRIGERANT LIQUID		



CHASE
PITTSBORO
NEW CONSTRUCTION

GENERAL NOTES

- ALL WORK SHALL COMPLY WITH 2018 NORTH CAROLINA MECHANICAL CODE WITH ALL LOCAL AMENDMENTS AND ORDINANCES; HENCEFORTH REFERRED TO AS THE NCMC.
- ALL SUPPLY, RETURN, OUTSIDE, AND EXHAUST AIR DUCTWORK INSIDE BUILDING SHALL BE WRAPPED WITH 2" INSULATION (MIN. R-6 INSTALLED). SIZES SHOWN ARE SHEET METAL DIMENSIONS.
- LAY-IN RETURN GRILLES SHALL BE EQUIPPED WITH PRICE MODEL RAC RETURN AIR CANOPY OR APPROVED EQUAL PRODUCT.
- PROVIDE PERMANENT PRINTED LABELS FOR THERMOSTATS INDICATING AREA(S) SERVED.
- CEILING SPACE IS BEING UTILIZED AS AN RA PLENUM. MATERIALS WITHIN PLENUM SPACE SHALL BE RATED FOR SUCH USE. NO PLASTIC PIPING PERMITTED IN CEILING PLENUM.
- CONTROLS FOR VRF SYSTEMS SHALL BE FURNISHED BY THE MECHANICAL CONTRACTOR. ALL OTHER HVAC EQUIPMENT SHALL BE CONTROLLED BY THE DAINTREE BMS PROVIDED BY ELECTRICAL. REFER TO ELECTRICAL DRAWINGS AND SPECIFICATIONS FOR ALL REQUIREMENTS. VRF CONTROLS SHALL TIE INTO DAINTREE FRONT END JACE PANEL.
- DAINTREE DEVICES ARE SHOWN ON MECHANICAL PLANS FOR COORDINATION PURPOSES AND TO SHOW SUGGESTED LOCATIONS. REFER TO ELECTRICAL DRAWINGS AND SPECIFICATIONS FOR ALL REQUIREMENTS.
- PROVIDE DAINTREE SUPPLY DUCT TEMPERATURE SENSOR IN ALL SUPPLY MAINS.
- AT EACH HVAC FAN MOTOR, PROVIDE DAINTREE CURRENT SENSOR WIRED TO WGA100 ADAPTER.
- PROVIDE DAINTREE OUTDOOR AIR TEMPERATURE SENSOR MOUNTED ON WALL ABOVE ELECTRIC METER/MAIN PANELS, UNLESS SHOWN OTHERWISE.
- COORDINATE EXACT HVAC SENSOR ROUGH-IN LOCATIONS IN FIELD WITH ARCHITECT/OWNER.
- TOP OF TEMPERATURE CONTROLS SHALL BE 40" A.F.F. UNLESS NOTED OTHERWISE.
- ALL AIR FLOWS SHALL BE BALANCED TO WITHIN +/- 10% OF SCHEDULED VALUES.
- PROVIDE A DUCT DETECTOR IN ALL RETURN AIR MAINS PER NCMC SECTION 606.2

KEYNOTES

- 10"x10" WRAPPED EXHAUST DUCT UP TO FAN ON ROOF.
- INDOOR UNIT SUSPENDED FROM ROOF STRUCTURE ABOVE CEILING, RE: 4M2.05 FOR DETAIL. RE: 1M2.02 FOR CONDENSATE DRAIN ROUTE.
- INDOOR UNIT MOUNTED ON WALL. RE: 1M2.02 CONDENSATE DRAIN ROUTE.
- DUCT RISE TO RUN ABOVE TRANSACTION VESTIBULE CEILING.
- BACKUP EXHAUST FAN INSTALLED INTO DATA ROOM, SUSPENDED FROM STRUCTURE ABOVE. ROUTE 12" DIA. EXHAUST DUCT THROUGH DATA ROOM WALL TO CEILING PLENUM. INSTALL 12" x 8" LOUVERED TRANSFER GRILLE IN WALL ADJACENT TO LOUNGE AS SHOWN. REFER TO BACK UP VENTILATION SYSTEM DETAIL, RE: 3M2.06.
- VRF BRANCH SELECTOR BOX, COORDINATE EXACT LOCATION IN FIELD TO MAINTAIN PROPER ACCESS.
- TRANSFER AIR DUCT TO PROVIDE RETURN AIR THROUGH UP TO DECK WALL. PROVIDE DUCTWORK IN CEILING SPACE.
- 16" x 16" WRAPPED OUTSIDE AIR DUCT UP TO INTAKE ON ROOF.
- PROVIDE REMOTE CABLE BALANCING CONTROL FOR THIS BRANCH DUCTWORK. DAMPER SHOWN FOR BRANCH SHALL BE YOUNG REGULATOR MODEL 5020CC2 OR EQUAL. PROVIDE YOUNG REGULATOR BOWDEN CABLE CONTROL SYSTEM MODEL 270-275-PH (PHILLIPS HEAD ADJUSTMENT TOOL) AND MOUNT OPERATOR ABOVE ACCESSIBLE CEILING AS SHOWN. SECURE OPERATOR TO WALL ABOVE CEILING AND PROVIDE PERMANENT LABEL FOR DAMPER DESCRIPTION.
- REMOTE CABLE CONTROL OPERATOR(S).
- OPEN END RA DUCT FOR PLENUM RETURN.
- DUCT TO RISE OVER ADJACENT HEAT PUMP UNIT.
- DUCT TO RISE AT A 45 DEGREE ANGLE.
- DUCT TO DROP AT A 45 DEGREE ANGLE.
- DUCT TO TURN AT A 90 DEGREE ANGLE TO AVOID BEAM.

1 HVAC FLOOR PLAN
1/4" = 1'-0"

3 HVAC SYMBOL SCHEDULE

	MECHANICAL EQUIPMENT DESIGNATION AHU, REFER TO MECHANICAL EQUIPMENT TYPES SCHEDULE		WALL-MOUNTED THERMOSTAT		TYPE "B" EXH GR. BALANCE TO CFM INDICATED, SEE EQUIPMENT SCHEDULE, OTHERS SIMILAR	RS	REFRIGERANT SUCTION
	LINEAR SLOT CEILING DIFFUSER TYPE "K", BALANCE TO 200 CFM. SLOT DIFFUSER TAGS WITHOUT A CFM LISTED INDICATE DIFFUSER IS BEING UTILIZED FOR RETURN. FURNISH WITH FBRI RETURN HOOD, REFER TO MECHANICAL SCHEDULES FOR SIZE AND CONFIGURATION		WALL-MOUNTED REMOTE TEMPERATURE SENSOR		TYPE "B" CEILING DIFFUSER (4 WAY THROW UNLESS NOTED OTHERWISE BY SHADING.) BALANCE TO 200 CFM, SEE EQUIPMENT SCHEDULE, OTHERS SIMILAR.	VOJ	VERIFY ON JOB
RA	RETURN AIR		WALL-MOUNTED REMOTE HUMIDITY SENSOR		DUCT TURNING VANE	SP	DUCT STATIC PRESSURE SENSOR FOR VRF SYSTEM BY MECHANICAL.
SA	SUPPLY AIR		DAINTREE WALL TIMER TO CONTROL EXHAUST FAN, RE: ELECTRICAL		6"x6" RECTANGULAR DUCT	FD	FIRE DAMPER. COORDINATE RATING WITH WALL TYPE.
EXH	EXHAUST AIR		IN-DUCT SMOKE DETECTOR TEST KEY SWITCHES BY MECHANICAL, HARDWIRE TO DETECTOR		12" DIAMETER ROUND DUCT	CO	CLEANOUT
OA	OUTSIDE AIR		REFERENCE TO MECHANICAL KEYNOTE NUMBER 1.		MANUAL BALANCING DAMPER (MBD)		
		RE: 2M2.01	REFER TO DETAIL 2, SHEET M2.01		MOTORIZED CONTROL DAMPER (MCD)		
			RETURN AIR GRILLE IN CEILING, SEE EQUIPMENT SCHEDULE, OTHERS SIMILAR.	RL	REFRIGERANT LIQUID		

5/20/2024 5:15:05 PM

5/20/2024 5:15:05 PM

National TAB

Project: JP Morgan Chase (Pittsboro,NC)
System/Unit: Heat Pump



Asset: DOAS-1

AREA:

Unit Data		
	Design	Actual
Unit MFG	LG	LG
Model Num	NA	ARND093DCR4
Serial Num	-	503UCSF00214
Type	-	DOAS
Configuration	-	HORIZONTAL
Num Filters Size 1	-	2
Filter Size 1	-	25X20X2

Test Data		
	Design	Actual
SA CFM	645	686
Motor Speed Setpt	-	47%
RL Voltage	208	213
RL Amperage	-	1.04
OA CFM	645	686

Performance Data		
	Design	Actual
Suction ESP	-	-0.067"
Discharge ESP	-	0.090"
Total ESP	-	0.157"

Motor Data		
	Design	Actual
Motor MFG	-	NL
Frame	-	NL
Horsepower	-	NL
Motor Rpm	-	NL
Phase	-	1
Voltage	-	208
Amperage	-	NL
Service Factor	-	NL

Completed By: Jearod Ferrette on 11/24/2025

National TAB

Project:JP Morgan Chase (Pittsboro,NC)

Heat Pump



Diffuser Supply (GRD)

DOAS-1/

Asset							
Asset Name	Location	Type	Size	DESIGN CFM	CFM(1)	FINAL CFM	% to design
D1-1	HP-2	DUCT	6	45	63	47	104.4
D1-2	HP-3	DUCT	6	25	77	23	92.0
D1-3	HP-1	DUCT	6	45	89	47	104.4
D1-4	102	K	8	145	278	155	106.9
D1-5	HP-4	DUCT	6	70	90	76	108.6
D1-6	HP-5	DUCT	8	160	301	173	108.1
D1-7	HP-6	DUCT	6	60	95	65	108.3
D1-8	HP-7	DUCT	6	95	120	100	105.3
Total				645	1113	686	106.36%

National TAB

Project: JP Morgan Chase (Pittsboro,NC)
System/Unit: Heat Pump



Asset: AH-1

AREA:100

Unit Data		
	Design	Actual
Unit MFG	LG	LG
Model Num	NA	KNUJB121A
Serial Num	-	501HAUJ5E558
Type	-	HEAT PUMP
Configuration	-	HORIZONTAL
Num Filters Size 1	-	2
Filter Size 1	-	(1)16X16X2/ (1) 16X20X2

Motor Data		
	Design	Actual
Motor MFG	-	NL
Frame	-	NL
Horsepower	-	NL
Motor Rpm	-	NL
Phase	-	1
Voltage	-	208
Amperage	-	NL
Service Factor	-	NL

Test Data		
	Design	Actual
SA CFM	370	377
Motor Speed Setpt	-	HIGH
RL Voltage	208	213
RL Amperage	-	0.63
RA CFM	370	377

Performance Data		
	Design	Actual
Suction ESP	-	-0.032"
Discharge ESP	-	0.022"
Total ESP	-	0.054"

Completed By: Jearod Ferrette on 11/20/2025

National TAB

Project:JP Morgan Chase (Pittsboro,NC)

Heat Pump



Diffuser Supply (GRD)

AH-1/100

Asset							
Asset Name	Location	Type	Size	DESIGN CFM	CFM(1)	FINAL CFM	% to design
A1-1	100	K	8	185	190	190	102.7
A1-2	100	K	8	185	187	187	101.1
Total				370	377	377	101.89%

National TAB

Project: JP Morgan Chase (Pittsboro,NC)
System/Unit: Heat Pump



Asset: HP-1

AREA:108

Unit Data		
	Design	Actual
Unit MFG	LG	LG
Model Num	NA	ARNU183MAA4
Serial Num	-	503HAFM03387
Type	-	HEAT PUMP
Configuration	-	HORIZONTAL
Num Filters Size 1	-	2
Filter Size 1	-	28X8.0625X0.1875

Test Data		
	Design	Actual
SA CFM	600	587
Motor Speed Setpt	-	HIGH
RL Voltage	208	213
RL Amperage	-	0.56
RA CFM	555	540
OA CFM	45	47

Motor Data		
	Design	Actual
Motor MFG	-	NL
Frame	-	NL
Horsepower	-	NL
Motor Rpm	-	NL
Phase	-	1
Voltage	-	208
Amperage	-	NL
Service Factor	-	NL

Performance Data		
	Design	Actual
Suction ESP	-	-0.015"
Discharge ESP	-	0.32"
Total ESP	-	0.335"

Completed By: Jearod Ferrette on 11/19/2025

National TAB

Project:JP Morgan Chase (Pittsboro,NC)

Heat Pump



Diffuser Supply (GRD)

HP-1/108

Asset							
Asset Name	Location	Type	Size	DESIGN CFM	CFM(1)	FINAL CFM	% to design
H1-1	108	L	8	300	115	289	96.3
H1-2	108	L	8	300	120	298	99.3
Total				600	235	587	97.83%

National TAB

Project: JP Morgan Chase (Pittsboro,NC)
System/Unit: Heat Pump



Asset: HP-2

AREA:105

Unit Data		
	Design	Actual
Unit MFG	LG	LG
Model Num	NA	ARNU243MAA4
Serial Num	-	502HAZX53141
Type	-	HEAT PUMP
Configuration	-	HORIZONTAL
Num Filters Size 1	-	2
Filter Size 1	-	28X8.0625X0.1875

Test Data		
	Design	Actual
SA CFM	810	749
Motor Speed Setpt	-	HIGH
RL Voltage	208	213
RL Amperage	-	0.91
RA CFM	765	702
OA CFM	45	47

Motor Data		
	Design	Actual
Motor MFG	-	NL
Frame	-	NL
Horsepower	-	NL
Motor Rpm	-	NL
Phase	-	1
Voltage	-	208
Amperage	-	NL
Service Factor	-	NL

Performance Data		
	Design	Actual
Suction ESP	-	-0.09"
Discharge ESP	-	0.11"
Total ESP	-	0.20"

Completed By: Jearod Ferrette on 11/19/2025

Notes:

CABLE DAMPERS 2-3 AND 2-4 ARE INACCESSIBLE FROM THE HARD CEILING. MECHANICAL WASN'T TO ADJUST THE CABLE ANYMORE. UNIT IS SET TO TOTAL FLOW.

Written By: Jearod Ferrette on 11/19/2025

National TAB

Project:JP Morgan Chase (Pittsboro,NC)

Heat Pump



Diffuser Supply (GRD)

HP-2/105

Asset							
Asset Name	Location	Type	Size	DESIGN CFM	CFM(1)	FINAL CFM	% to design
H2-1	104	G	10	410	170	206	50.2
H2-2	105	N	8	100	145	109	109.0
H2-3	105	N	8	100	134	114	114.0
H2-4	105	N	8	100	170	229	229.0
H2-5	105	N	8	100	136	91	91.0
Total				810	755	749	92.47%

National TAB

Project: JP Morgan Chase (Pittsboro,NC)
System/Unit: Heat Pump



Asset: HP-3

AREA:103

Unit Data		
	Design	Actual
Unit MFG	LG	LG
Model Num	NA	ARNU093MAA4
Type	-	HEAT PUMP
Configuration	-	HORIZONTAL
Num Filters Size 1	-	2
Filter Size 1	-	28X8.0625X0.1875

Test Data		
	Design	Actual
SA CFM	315	321
Motor Speed Setpt	-	HIGH
RL Voltage	208	214
RL Amperage	-	0.35
RA CFM	290	298
OA CFM	25	23

Motor Data		
	Design	Actual
Motor MFG	-	NL
Frame	-	NL
Horsepower	-	NL
Motor Rpm	-	NL
Phase	-	1
Voltage	-	208
Amperage	-	NL
Service Factor	-	NL

Performance Data		
	Design	Actual
Suction ESP	-	-0.15"
Discharge ESP	-	0.11"
Total ESP	-	0.26"

Completed By: Jearod Ferrette on 11/19/2025

National TAB

Project:JP Morgan Chase (Pittsboro,NC)

Heat Pump



Diffuser Supply (GRD)

HP-3/103

Asset							
Asset Name	Location	Type	Size	DESIGN CFM	CFM(1)	FINAL CFM	% to design
H3-1	103	G	10	315	321	321	101.9
Total				315	321	321	101.9%

National TAB

Project: JP Morgan Chase (Pittsboro,NC)
System/Unit: Heat Pump



Asset: HP-4

AREA:119

Unit Data		
	Design	Actual
Unit MFG	LG	LG
Model Num	NA	ARNU183MAA4
Serial Num	-	503HABZ03389
Type	-	HEAT PUMP
Configuration	-	HORIZONTAL
Num Filters Size 1	-	2
Filter Size 1	-	28X8.0625X0.1875

Test Data		
	Design	Actual
SA CFM	600	587
Motor Speed Setpt	-	HIGH
RL Voltage	208	214
RL Amperage	-	0.60
RA CFM	530	514
OA CFM	70	76

Motor Data		
	Design	Actual
Motor MFG	-	NL
Frame	-	NL
Horsepower	-	NL
Motor Rpm	-	NL
Phase	-	1
Voltage	-	208
Amperage	-	NL
Service Factor	-	NL

Performance Data		
	Design	Actual
Suction ESP	-	-0.048"
Discharge ESP	-	0.120"
Total ESP	-	0.168"

Completed By: Jearod Ferrette on 11/24/2025

National TAB

Project:JP Morgan Chase (Pittsboro,NC)

Heat Pump



Diffuser Supply (GRD)

HP-4/119

Asset							
Asset Name	Location	Type	Size	DESIGN CFM	CFM(1)	FINAL CFM	% to design
H4-1	119	B	8	185	132	173	93.5
H4-2	118	J	8	85	134	90	105.9
H4-3	119	B	8	185	121	174	94.1
H4-4	118	J	8	85	120	92	108.2
H4-5	120	A	6	60	72	58	96.7
Total				600	579	587	97.83%

National TAB

Project: JP Morgan Chase (Pittsboro,NC)
System/Unit: Heat Pump



Asset: HP-5

AREA:102

Unit Data		
	Design	Actual
Unit MFG	LG	LG
Model Num	NA	ARNU363M2A4
Serial Num	-	503KIAW01560
Type	-	HEAT PUMP
Configuration	-	HORIZONTAL
Num Filters Size 1	-	2
Filter Size 1	-	9.6875X23.9375X0.1875

Test Data		
	Design	Actual
SA CFM	1130	1149
Motor Speed Setpt	-	HIGH
RL Voltage	208	213
RL Amperage	-	0.73
RA CFM	970	981
OA CFM	160	173

Motor Data		
	Design	Actual
Motor MFG	-	NL
Frame	-	NL
Horsepower	-	NL
Motor Rpm	-	NL
Phase	-	1
Voltage	-	208
Amperage	-	NL
Service Factor	-	NL

Performance Data		
	Design	Actual
Suction ESP	-	-0.041
Discharge ESP	-	0.20"
Total ESP	-	0.241"

Completed By: Jearod Ferrette on 11/20/2025

National TAB

Project:JP Morgan Chase (Pittsboro,NC)

Heat Pump



Diffuser Supply (GRD)

HP-5/102

Asset							
Asset Name	Location	Type	Size	DESIGN CFM	CFM(1)	FINAL CFM	% to design
H5-1	102	K	8	140	180	150	107.1
H5-2	102	K	8	250	130	230	92.0
H5-3	102	K	8	250	30	261	104.4
H5-4	102	K	8	240	390	238	99.2
H5-5	110	K	8	250	411	270	108.0
Total				1130	1141	1149	101.68%

National TAB

Project: JP Morgan Chase (Pittsboro,NC)
System/Unit: Heat Pump



Asset: HP-6

AREA:112

Unit Data		
	Design	Actual
Unit MFG	LG	LG
Model Num	NA	ARNU243MAA4
Serial Num	-	502HASP53142
Type	-	HEAT PUMP
Configuration	-	HORIZONTAL
Num Filters Size 1	-	2
Filter Size 1	-	28X8.0625X0.1875

Test Data		
	Design	Actual
SA CFM	740	717
Motor Speed Setpt	-	HIGH
RL Voltage	208	213
RL Amperage	-	0.69
RA CFM	680	655
OA CFM	60	65

Motor Data		
	Design	Actual
Motor MFG	-	NL
Frame	-	NL
Horsepower	-	NL
Motor Rpm	-	NL
Phase	-	1
Voltage	-	208
Amperage	-	NL
Service Factor	-	NL

Performance Data		
	Design	Actual
Suction ESP	-	-0.081"
Discharge ESP	-	0.100"
Total ESP	-	0.181"

Completed By: Jearod Ferrette on 11/24/2025

National TAB
 Project:JP Morgan Chase (Pittsboro,NC)
Heat Pump



Diffuser Supply (GRD)

HP-6/112

Asset							
Asset Name	Location	Type	Size	DESIGN CFM	CFM(1)	FINAL CFM	% to design
H6-1	112	C	10	290	258	274	94.5
H6-2	111	G	10	225	291	213	94.7
H6-3	109	G	10	225	160	230	102.2
Total				740	709	717	96.89%

National TAB

Project: JP Morgan Chase (Pittsboro,NC)
System/Unit: Heat Pump



Asset: HP-7

AREA:116

Unit Data		
	Design	Actual
Unit MFG	LG	LG
Model Num	NA	ARNU243MAA4
Serial Num	-	502HALW53144
Type	-	HEAT PUMP
Configuration	-	HORIZONTAL
Num Filters Size 1	-	2
Filter Size 1	-	28X8.0625X0.1875

Test Data		
	Design	Actual
SA CFM	810	786
Motor Speed Setpt	-	HIGH
RL Voltage	208	213
RL Amperage	-	.56
RA CFM	715	686
OA CFM	95	100

Motor Data		
	Design	Actual
Motor MFG	-	NL
Frame	-	NL
Horsepower	-	NL
Motor Rpm	-	NL
Phase	-	1
Voltage	-	208
Amperage	-	NL
Service Factor	-	NL

Performance Data		
	Design	Actual
Suction ESP	-	-0.064"
Discharge ESP	-	0.165"
Total ESP	-	0.229"

Completed By: Alex Bauer on 11/24/2025

National TAB

Project:JP Morgan Chase (Pittsboro,NC)

Heat Pump



Diffuser Supply (GRD)

HP-7/116

Asset							
Asset Name	Location	Type	Size	DESIGN CFM	CFM(1)	FINAL CFM	% to design
H7-1	116	B	8	190	145	187	98.4
H7-2	116	B	8	190	135	175	92.1
H7-3	121	B	8	190	137	186	97.9
H7-4	116	B	8	105	94	100	95.2
H7-5	113	A	6	60	56	61	101.7
H7-6	114	A	6	30	67	32	106.7
H7-7	115	A	6	45	37	45	100.0
Total				810	671	786	97.04%

National TAB

Project: JP Morgan Chase (Pittsboro,NC)
System/Unit: FAN - Exhaust



Asset: EF-1

AREA:BUILDING EXHAUST

Unit Data		
	Design	Actual
MFG	NA	GREENHECK
Model Num	NA	G-090-D
Serial Num	-	301461
Type	-	CRE

Test Data		
	Design	Actual
CFM	350	578
System SetPt	-	SINGLE SPEED
RL Voltage	120	120
RL Amperage	-	1.29
Suction ESP	-	-0.21"
Total ESP	-	0.21"

Motor Data		
	Design	Actual
Motor MFG	-	McMillan electric
Frame	-	NA
Horsepower	-	0.06
Motor Rpm	-	1550
Phase	-	1
Voltage (rated)	-	120
Amperage (rated)	-	1.2
Service Factor	-	1

Completed By: Alex Bauer on 11/24/2025

Notes:
EF1 no speed controller installed.

Written By: Scott Springer on 11/25/2025

National TAB

Project:JP Morgan Chase (Pittsboro,NC)

FAN - Exhaust



Diffuser Ret/Exh (GRD)

EF-1/BUILDING EXHAUST

Asset								
Asset Name	Location	Type	Size	DESIGN CFM	AK	CFM(1)	FINAL CFM	% to design
E1-1	115	B	8	75	1	162	162	216.0
E1-2	114	B	8	75	1	163	163	217.3
E1-3	116	B	8	150	1	199	199	132.7
E1-4	116A	C	6	50	0.18	54	54	108.0
Total				350		578	578	165.14%

National TAB

Project: JP Morgan Chase (Pittsboro,NC)
System/Unit: FAN - Exhaust



Asset: EF-2

AREA:DATA ROOM

Unit Data		
	Design	Actual
MFG	NA	GREENHECK
Model Num	NA	SP-A510
Serial Num	-	27553932
Type	-	CEILING

Test Data		
	Design	Actual
CFM	500	407
System SetPt	-	HIGH
RL Voltage	120	120
RL Amperage	-	3.42
Suction ESP	-	-0.16"
Total ESP	-	0.16"

Motor Data		
	Design	Actual
Motor MFG	-	GREENHECK
Frame	-	NL
Horsepower	-	224W
Motor Rpm	-	1049
Phase	-	1
Voltage (rated)	-	115
Amperage (rated)	-	NL
Service Factor	-	NL

Completed By: Alex Bauer on 11/24/2025

Notes:
The fan is controlled using a thermostat dial set at one speed.

Written By: Scott Springer on 11/25/2025