



**HIPP
DESIGN +
CONSULTING**

SHOP DRAWING / SUBMITTAL ACTION TICKET

CLIENT NAME	Eli Lilly
CONSTRUCTION MANAGER	BE&K
PROJECT NAME	Project Concord DAP
PROJECT NUMBER	G22131

SUBMITTAL NUMBER: #073		SUBMITTAL TITLE: Fan Coils Units Bldg 2 Rev 1	
CONTRACTOR / VENDOR: Kirlin-Way Mechanical		DATE RECEIVED: 17APR2023	
RECEIVED BY: NR		DATE DUE: 26APR2023	
DISPOSITION: <input checked="" type="checkbox"/> NO EXCEPTION TAKEN <input type="checkbox"/> APPROVED AS NOTED <input type="checkbox"/> REVISE AND RESUBMIT <input type="checkbox"/> REJECTED, RESUBMIT <input type="checkbox"/> NOT REVIEWED		DISTRIBUTION: <input type="checkbox"/> CIVIL _____ <input type="checkbox"/> ARCHITECTURAL _____ <input type="checkbox"/> STRUCTURAL _____ <input checked="" type="checkbox"/> MECHANICAL <u>A. Anderson</u> <input type="checkbox"/> PROCESS _____ <input checked="" type="checkbox"/> ELECTRICAL <u>J. Millikin</u> <input checked="" type="checkbox"/> INST & CONT. <u>J. Caplan</u> <input type="checkbox"/> PROJ. LEADER _____ <input type="checkbox"/> OTHER _____	

Checking is only for general conformance with the design concept of the project and general compliance with the information given in the contract documents. Any action shown is subject to the requirements of the plans and specifications. Contractor is responsible for dimensions which shall be confirmed and correlated at the job site; fabrication processes and techniques of construction, coordination of his work with that of all other trades, and the satisfactory performance of his work.

REMARKS:

I&C Comments: No exception taken.

Electrical Comments: No comments.

HVAC Comments: No exception taken.

Adam J. Anderson, P.E.

 PRIMARY DISCIPLINE LEAD

Mechanical

 DISCIPLINE

24APR2023

 DATE



BE&K Building Group
 100 Capitola Drive
 Suite 301
 Durham, North Carolina 27713
 P: (919) 781-0054

Project: 306232 Lilly — DAP, Warehouse Interface, + Central Corridor Fit Out
 1420 Concord Parkway South
 Concord, North Carolina 28027

Submittal #238219-034.1 - Fan Coils Units Building 2 238219 - Fan Coil Units

Revision	1	Submittal Manager	Dylan Driscoll (BE&K Building Group - Raleigh)
Status	Open	Date Created	Mar 16, 2023
Issue Date	Mar 16, 2023	Spec Section	238219 - Fan Coil Units
Responsible Contractor	Kirlin-Way Mechanical, LLC	Received From	Jason Brindle (Kirlin-Way Mechanical, LLC)
Received Date	Mar 7, 2023	Submit By	
Final Due Date	May 4, 2023	Lead Time	
		Cost Code	
Location		Type	Product Data
Approvers	Natasha Rampersaud (Hipp Engineering & Consulting Inc), Alex Stone (Hipp Engineering & Consulting Inc), Dylan Driscoll (BE&K Building Group - Raleigh)		
Ball in Court	Natasha Rampersaud (Hipp Engineering & Consulting Inc), Alex Stone (Hipp Engineering & Consulting Inc)		
Distribution	Jason Brindle (Kirlin-Way Mechanical, LLC), Jonathon Ross (Kirlin-Way Mechanical, LLC), Brandon Walker (Kirlin-Way Mechanical, LLC), Natasha Rampersaud (Hipp Engineering & Consulting Inc), Alex Stone (Hipp Engineering & Consulting Inc), Dylan Driscoll (BE&K Building Group - Raleigh)		
Description	This is the revision for the FCU's for Building 2		

Submittal Workflow

Name	Sent Date	Due Date	Returned Date	Response	Attachments
General Information Attachments					SUBMITTAL - ELI LILLY Project Concord - Fan Coils BLDG 2 REV.1.pdf
Natasha Rampersaud	Apr 17, 2023	May 1, 2023		Pending	
Alex Stone	Apr 17, 2023	May 1, 2023		Pending	
Dylan Driscoll		May 4, 2023		Pending	



KIRLIN-WAY MECH PROJECT NAME: Eli Lilly Concord

KIRLIN WAY MECH
SUBMITTAL NO: 035

SUBMITTAL DATA

ARCHITECT: Hansbury
223 S. Wilmington Street, Suite 200
Raleigh, NC 27601

Submittal Date: 3/7/2023

ENGINEER: HIPP Design & Consulting
2301 Rexwoods Dr. #200
Raleigh, NC 27607

GENERAL CONTRACTOR: BE&K
SUBCONTRACTOR:

Specification Section: 40 97 00
Description: VFD's Building 2 Rev.1
Vendor / Supplier: Hoffman & Hoffman
Manufacturer: ABB

Clarifications:

Deviations:

Substitutions:

Submittal Prepared By: Jason Brindle
Phone: 704-785-6853
Email: Jbrindle@kirlinway.com

LOCATION: Raleigh, NC

DATE: 4/17/23

SALESMAN: Bennett Funderburk **ORDER #** 620.621.1XXX

PROJECT: *ELI LILLY Project Concord*

ENGINEER: *HIPP*

CONTRACTOR: *Kirlin Way Mechanical*

PRODUCT(S): *Fan Coils BLDG 2 Rev1*

MANUFACTURER(S): *Daikin*



SUBMITTAL DATA

APPROVAL REQUIRED

HOFFMAN • HOFFMAN, INC.

HVAC Manufacturers Representative

Website: www.hoffman-hoffman.com

Asheville, NC	(828) 296-0111	Charleston, SC	(843) 884-3201
Charlotte, NC	(704) 364-4700	Columbia, SC	(803) 765-9360
Raleigh, NC	(919) 781-8011	Greenville, SC	(864) 676-1888
Wilmington, NC	(910) 791-4775	Chesapeake, VA	(757) 548-1700
Chattanooga, TN	(423) 693-2890	Richmond, VA	(804) 272-1500
Knoxville, TN	(865) 540-9770	Roanoke, VA	(540) 725-8701

Corporate: Greensboro, NC (336) 292-8777

We have exercised care in the preparation of this submittal. We believe it satisfies our interpretation of the designer's intent and scope. It contains the list of materials, quantities, sizes, style and the finish as we propose to furnish for this job. Please examine and check carefully that all items are exactly as required and that our interpretation of the applicable plans and/or specifications are consistent with the design. Approval by the engineer and purchaser will be required before release of this equipment for production. If any discrepancies are discovered, please notify us as soon as possible.



SUBMITTAL DATA

Job Name

ELI LILLY

Table of Contents

Daikin Section Divider	3
Technical Data Sheet - FCU-5901A thru FCU-5901K	4
Fan Curve - Supply - FCU-5901A thru FCU-5901K	7
Drawings(Clearance View) - FCU-5901A thru FCU-5901K	8
Drawings(Front Bottom) - FCU-5901A thru FCU-5901K	9
Drawings(Top Back) - FCU-5901A thru FCU-5901K	10
PreciseLine Drawings - FCU-5901A thru FCU-5901K	11
Technical Data Sheet - FCU-5901L thru FCU-5901V	17
Fan Curve - Supply - FCU-5901L thru FCU-5901V	20
Drawings(Clearance View) - FCU-5901L thru FCU-5901V	21
Drawings(Front Bottom) - FCU-5901L thru FCU-5901V	22
Drawings(Top Back) - FCU-5901L thru FCU-5901V	23
PreciseLine Drawings - FCU-5901L thru FCU-5901V	24

Daikin Section Divider



Job Information		Technical Data Sheet
Job Name	ELI LILLY	
Date	4/17/2023	
Submitted By	Vijay Periannan	
Software Version	05.70	
Unit Tag	FCU-5901A , FCU-5901B, FCU-5901C, FCU-5901D, FCU-5901E, FCU-5901F, FCU-5901G, FCU-5901H, FCU-5901J, FCU-5901K	



Unit Overview				
Model Number	Voltage V/Hz/Phase	Airflow CFM	External Static Pressure inH ₂ O	Design Cooling Capacity Btu/hr
BCHE0301	460/60/3	2500	1.00	65060

Unit	
Model Number:	BCHE0301
Unit Arrangement:	Horizontal
Altitude:	705 ft

Physical			
Dimensions and Weight (wet)			
Length	Height	Width	Weight
40 in	26.0 in	49.0 in	567 lb
Construction			
Insulation and Liners:	1" Injected Foam, R-6, Galvanized Steel Liner		

Electrical			
Field Connection	M CA	M ROPD	SCCR
Toggle Disconnect Switch	7.0	15	5 kA

Filter					
Filter Access	Filter Depth		MERV Rating		(Quantity) Height x Width x Depth (each bank)
	1 st Filter	2 nd Filter	1 st Filter	2 nd Filter	
Bottom	2 in	2 in	MERV 13	MERV 15	(2) 25.38 x 21.88

Primary Hydronic Coil

Physical					
Fins per Inch	Rows	Casing Material	Face Area ft ²	Face Velocity ft/min	
12	4	Stainless Steel	6.0	414.3	
Connection					
Size	Type		Location		
1.38	F-SWT		Left Hand		
Drain Pan					
Material			Connection		
Stainless Steel			0.75 in		
Performance					
Capacity		Air Temperature			
Total Btu/hr	Sensible Btu/hr	Entering		Leaving	
		Dry Bulb °F	Wet Bulb °F	Dry Bulb °F	Wet Bulb °F
65060	56149	72.0	60.0	50.9	50.4
Fluid					
Type	Entering Temperature °F	Leaving Temperature °F	Flow Rate gpm	Pressure Drop ft H ₂ O	
Water	42.0	50.3	15.6	4.55	

Secondary Hydronic Coil

Physical					
Fins per Inch	Rows	Casing Material	Face Area ft ²	Face Velocity ft/min	
12	1	Stainless Steel	6.0	414.3	
Connection					
Size	Type		Location		
0.62	F-SWT		Left Hand		
Performance					
Total Btu/hr	Air Temperature				
	Dry Bulb °F		Dry Bulb °F		
66785	60.0		85.1		
Fluid					
Type	Entering Temperature °F	Leaving Temperature °F	Flow Rate gpm	Pressure Drop ft H ₂ O	
Water	130.0	114.1	8.5	8.59	

Supply Fan

Performance							
Airflow	Total Static Pressure	Fan Speed	Controller Input Signal	Brake Horsepower	Total Input Power	Fan Energy Index	Altitude
2500	3.52 inH ₂ O	2713 rpm	8.1 VDC	1.99 HP	2.23 HP	1.553	705 ft
Motor							
Type	Horsepower	Motor Control				FLA	
Premium Efficiency	4.42 Hp	0-10V Modulating				5.6 A	

Unit Discharge Conditions

Air Temperature			
Motor Heat Btu/hr	Unit Leaving Dry Bulb °F	Unit Leaving Wet Bulb °F	Unit Leaving Dewpoint °F
5830	53.1	51.1	49.6

Internal Pressure Drop Calculation

External Static Pressure:	1.00 inH ₂ O
Filter:	0.29 inH ₂ O
Second Filter:	0.29 inH ₂ O
Dirty Filter:	1.50 inH ₂ O
Chilled Water Coil:	0.35 inH ₂ O
Hot Water Heat:	0.08 inH ₂ O
Total Static Pressure:	3.52 inH ₂ O

Options

Controls	
Overflow Switch:	Factory mounted Overflow Switch

Warranty

Parts:	Standard warranty
--------	-------------------

AHRI Certification



All equipment is rated and certified in accordance with AHRI 430.

Notes

Daikin Air Handler Packaged Fan Selection

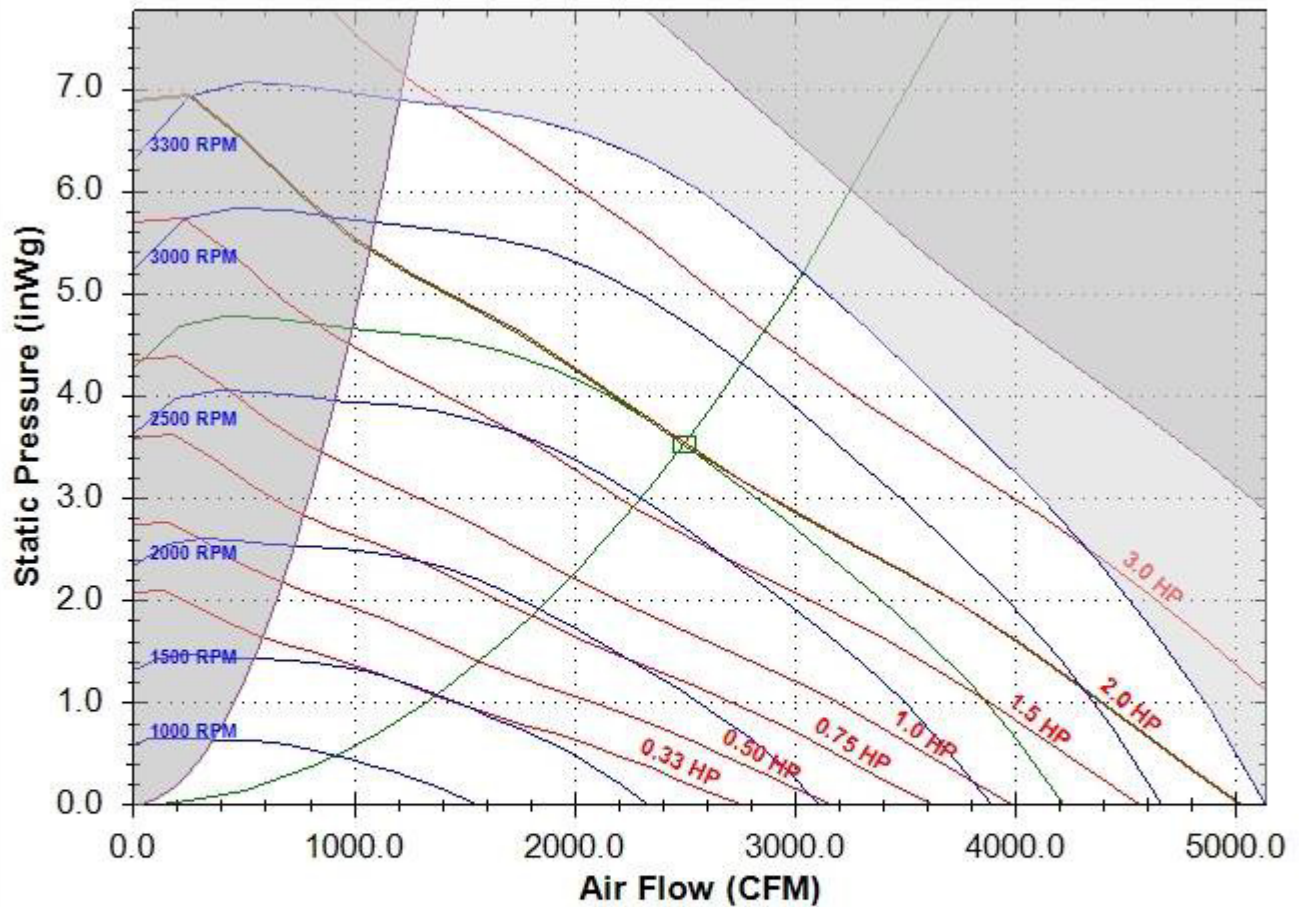

355.0 SWSI_AF Supply Fan at 705 ft Altitude				
Base Tag	FCU-5901A thru FCU-5901K		Date	Apr-17-2023
Job Name	ELI LILLY		Time	3:16 PM
Air Volume	2500	CFM	Fan Speed	2713 RPM
Total Static	3.52	inWg	Max Speed	3300 RPM
Brake Horsepower	1.99	HP	Efficiency	69.6 %



SFONUE

ELI LILLY

8

4/17/2023

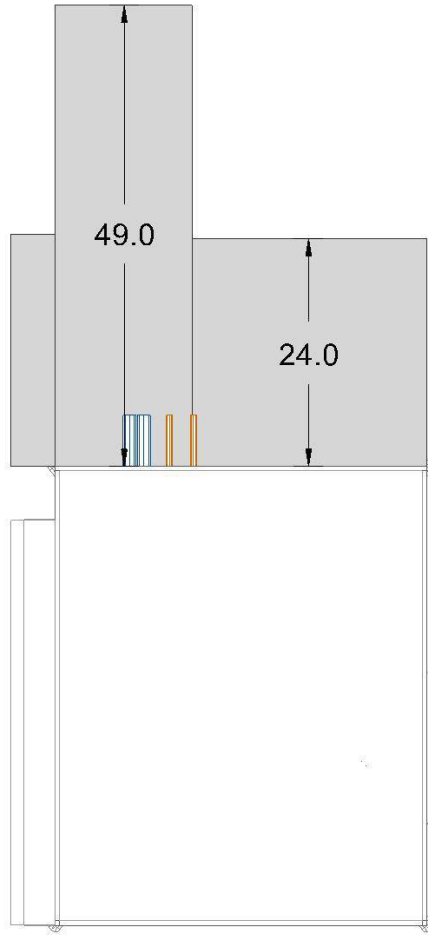

PLAN VIEW - SERVICE CLEARANCE

FCU-5901A thru FCU-5901K

Drawings(Clearance View)

Clearance View		Unit Tag: FCU-5901A thru FCU-5901K			Sales Office: Hoffman & Hoffman, Inc.			 13600 Industrial Park Blvd. Minneapolis, MN 55441 www.DaikinApplied.com Software Version: 05.61
Product: PreciseLine® Air Handler		Project Name: ELI LILLY			Sales Engineer:			
Model: BCHE0301		Mar. 06, 2023	Ver/Rev:	Sheet: 1 of 1	Scale: NTS	Tolerance: +/- 0.25"	Dwg Units: in [mm]	

No change to this drawing may be made unless approved in writing by Daikin Applied. Purchaser must determine that the equipment is fit and sufficient for the job specifications.

SFONUUE

ELI LILLY

9

4/17/2023

FCU-5901A thru FCU-5901K

Drawings(Front Bottom)

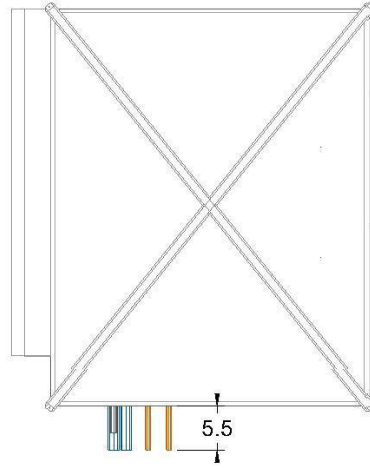

BOTTOM VIEW

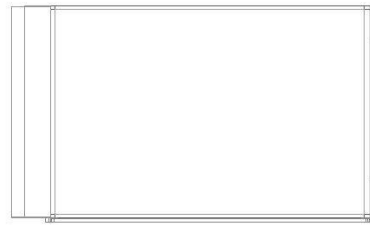

BACK VIEW

Front Bottom		Unit Tag: FCU-5901A thru FCU-5901K			Sales Office: Hoffman & Hoffman, Inc.			 13600 Industrial Park Blvd. Minneapolis, MN 55441 www.DaikinApplied.com Software Version: 05.61
Product: PreciseLine® Air Handler		Project Name: ELI LILLY			Sales Engineer:			
Model: BCHE0301	Mar. 06, 2023	Ver/Rev:	Sheet: 1 of 1	Scale: NTS	Tolerance: +/- 0.25"	Dwg Units: in [mm]		

No change to this drawing may be made unless approved in writing by Daikin Applied. Purchaser must determine that the equipment is fit and sufficient for the job specifications.

SFONUUE

ELI LILLY

10

4/17/2023

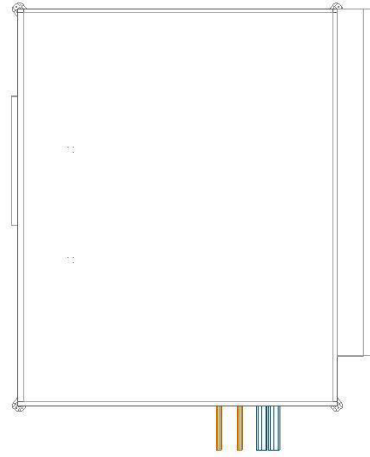

TOP VIEW

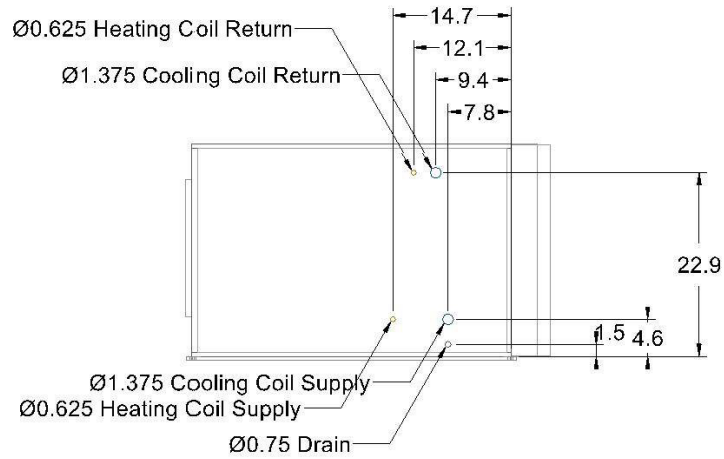

FRONT VIEW

FCU-5901A thru FCU-5901K

Drawings(Top Back)

Top Back		Unit Tag: FCU-5901A thru FCU-5901K			Sales Office: Hoffman & Hoffman, Inc.			 13600 Industrial Park Blvd. Minneapolis, MN 55441 www.DaikinApplied.com Software Version: 05.61
Product: PreciseLine® Air Handler		Project Name: ELI LILLY			Sales Engineer:			
Model: BCHE0301	Mar. 06, 2023	Ver/Rev:	Sheet: 1 of 1	Scale: NTS	Tolerance: +/- 0.25"	Dwg Units: in [mm]		

No change to this drawing may be made unless approved in writing by Daikin Applied. Purchaser must determine that the equipment is fit and sufficient for the job specifications.

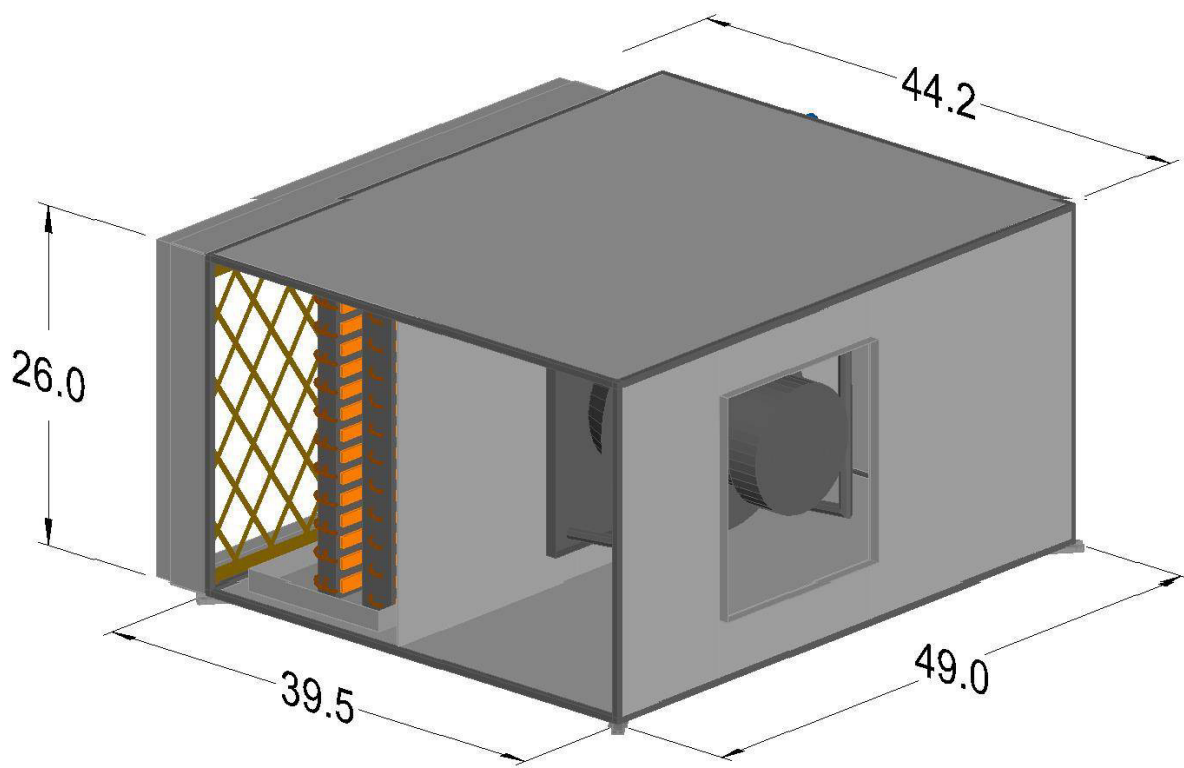

SFONUE

ELI LILLY

11

4/17/2023

FCU-5901A thru FCU-5901K

Preciseline Drawings

Unit Tag: FCU-5901A thru FCU-5901K		Sales Office: Hoffman & Hoffman, Inc.			 13600 Industrial Park Blvd. Minneapolis, MN 55441 www.DaikinApplied.com Software Version: 05.70			
Product: PreciseLine® Air Handler		Sales Engineer:						
Model: BCHE0301		Project Name: ELI LILLY	Apr. 17, 2023	Ver/Rev:	Sheet: 1 of 1	Scale: NTS	Tolerance: +/- 0.25"	Dwg Units: in [mm]

No change to this drawing may be made unless approved in writing by Daikin Applied. Purchaser must determine that the equipment is fit and sufficient for the job specifications.

SFONUUE

ELI LILLY

12

4/17/2023

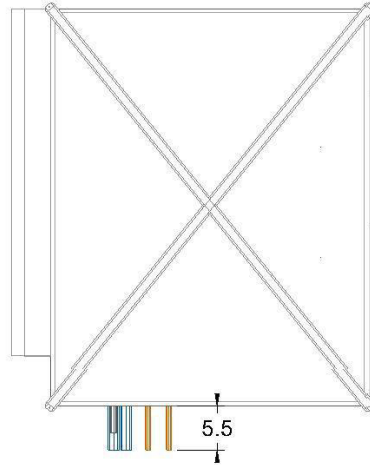

BOTTOM VIEW

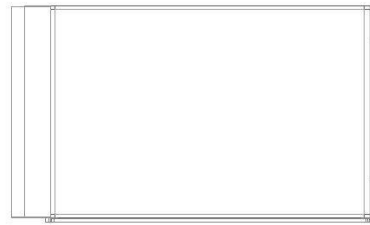

BACK VIEW

FCU-5901A thru FCU-5901K

Preciseline Drawings

Product: PreciseLine® Air Handler		Unit Tag: FCU-5901A thru FCU-5901K		Sales Office: Hoffman & Hoffman, Inc.			 13600 Industrial Park Blvd. Minneapolis, MN 55441 www.DaikinApplied.com Software Version: 05.70
Model: BCHE0301		Project Name: ELI LILLY		Sales Engineer:			
Apr. 17, 2023	Ver/Rev:	Sheet: 1 of 1	Scale: NTS	Tolerance: +/- 0.25"	Dwg Units: in [mm]		

No change to this drawing may be made unless approved in writing by Daikin Applied. Purchaser must determine that the equipment is fit and sufficient for the job specifications.

SF0NUUE

ELI LILLY

13

4/17/2023

FCU-5901A thru FCU-5901K

Preciseline Drawings

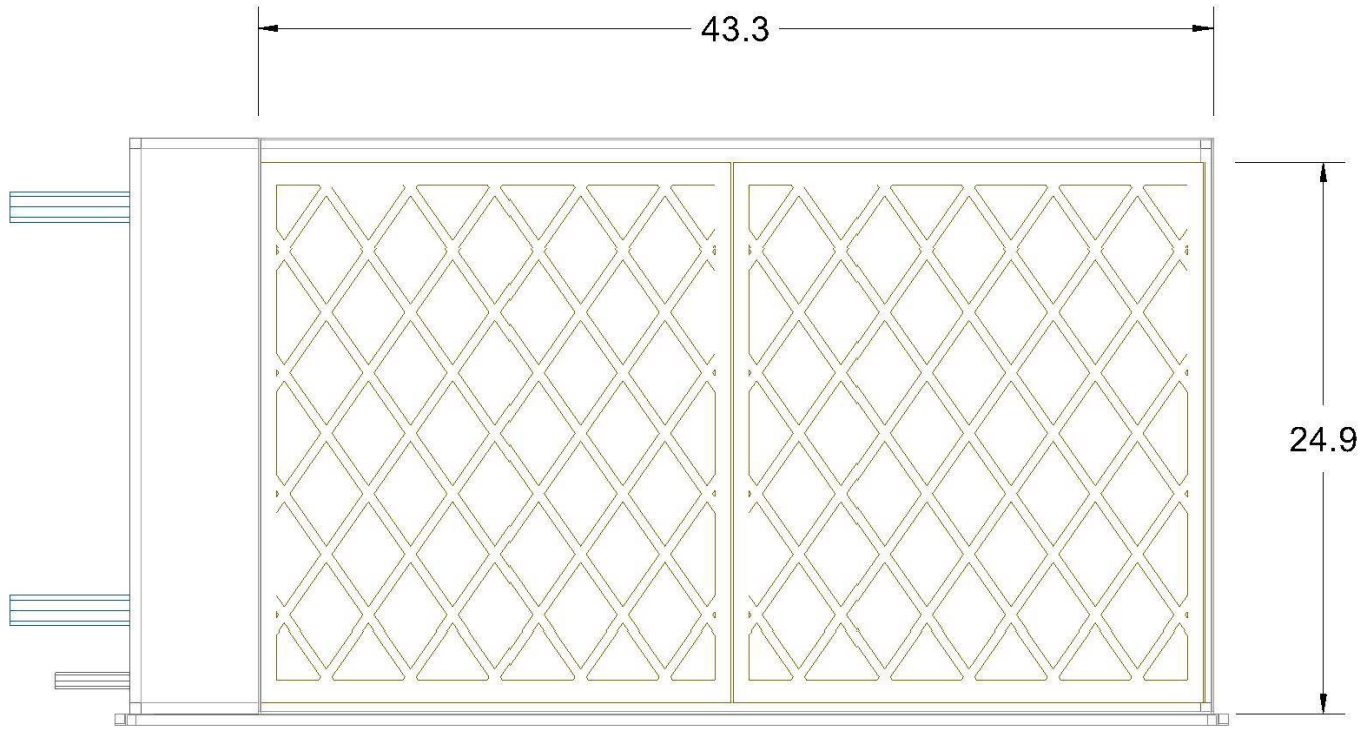

RIGHT VIEW

Product: PreciseLine® Air Handler		Unit Tag: FCU-5901A thru FCU-5901K			Sales Office: Hoffman & Hoffman, Inc.			 13600 Industrial Park Blvd. Minneapolis, MN 55441 www.DaikinApplied.com Software Version: 05.70
Model: BCHE0301		Project Name: ELI LILLY			Sales Engineer:			
Apr. 17, 2023	Ver/Rev:	Sheet: 1 of 1	Scale: NTS	Tolerance: +/- 0.25"	Dwg Units: in [mm]			

No change to this drawing may be made unless approved in writing by Daikin Applied. Purchaser must determine that the equipment is fit and sufficient for the job specifications.

SFONUE

ELI LILLY

14

4/17/2023



FCU-5901A thru FCU-5901K

Preciseline Drawings

Product: PreciseLine® Air Handler		Unit Tag: FCU-5901A thru FCU-5901K		Sales Office: Hoffman & Hoffman, Inc.			 13600 Industrial Park Blvd. Minneapolis, MN 55441 www.DaikinApplied.com Software Version: 05.70
Model: BCHE0301		Project Name: ELI LILLY		Sales Engineer:			
Apr. 17, 2023	Ver/Rev:	Sheet: 1 of 1	Scale: NTS	Tolerance: +/- 0.25"	Dwg Units: in [mm]		

No change to this drawing may be made unless approved in writing by Daikin Applied. Purchaser must determine that the equipment is fit and sufficient for the job specifications.

SFONUUE

ELI LILLY

15

4/17/2023

FCU-5901A thru FCU-5901K

Preciseline Drawings

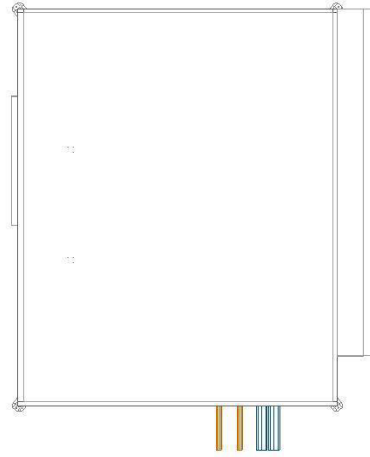

TOP VIEW

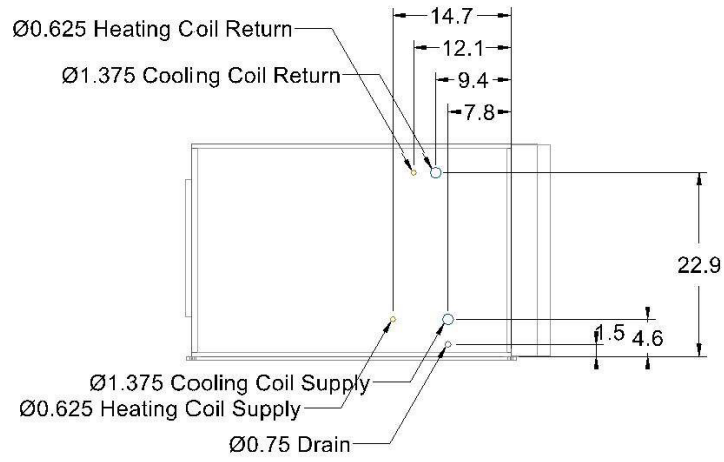

FRONT VIEW

Product: PreciseLine® Air Handler		Unit Tag: FCU-5901A thru FCU-5901K		Sales Office: Hoffman & Hoffman, Inc.			 13600 Industrial Park Blvd. Minneapolis, MN 55441 www.DaikinApplied.com Software Version: 05.70
Model: BCHE0301		Project Name: ELI LILLY		Sales Engineer:			
Apr. 17, 2023	Ver/Rev:	Sheet: 1 of 1	Scale: NTS	Tolerance: +/- 0.25"	Dwg Units: in [mm]		

No change to this drawing may be made unless approved in writing by Daikin Applied. Purchaser must determine that the equipment is fit and sufficient for the job specifications.

SFONUE

ELI LILLY

16

4/17/2023

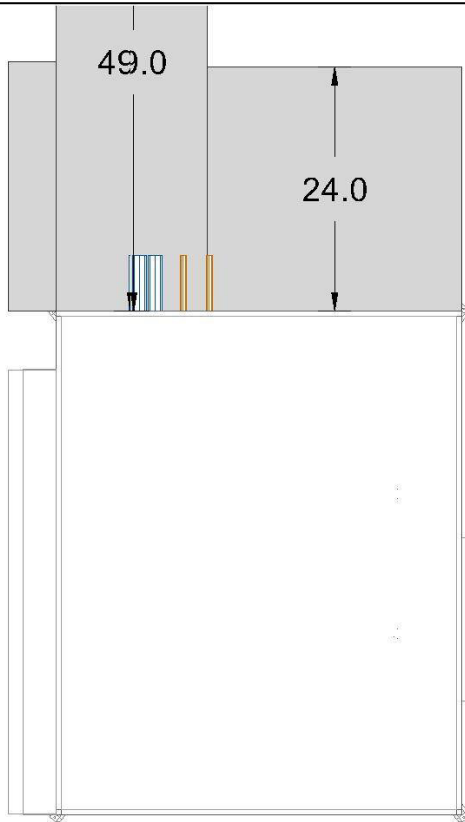

Plan View - Service Clearance

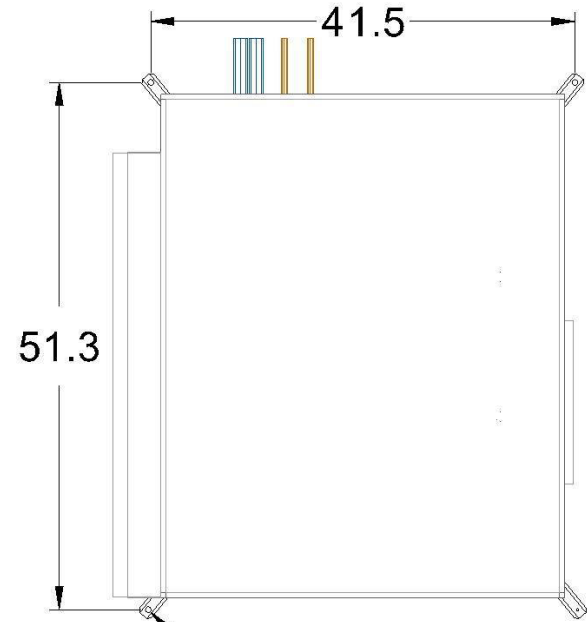

Plan View - Mounting

FCU-5901A thru FCU-5901K

Preciseline Drawings

Product: PreciseLine® Air Handler		Unit Tag: FCU-5901A thru FCU-5901K		Sales Office: Hoffman & Hoffman, Inc.			 13600 Industrial Park Blvd. Minneapolis, MN 55441 www.DaikinApplied.com Software Version: 05.70
Model: BCHE0301		Project Name: ELI LILLY		Sales Engineer:			
Apr. 17, 2023	Ver/Rev:	Sheet: 1 of 1	Scale: NTS	Tolerance: +/- 0.25"	Dwg Units: in [mm]		

No change to this drawing may be made unless approved in writing by Daikin Applied. Purchaser must determine that the equipment is fit and sufficient for the job specifications.

Job Information		Technical Data Sheet
Job Name	ELI LILLY	
Date	4/17/2023	
Submitted By	Vijay Periannan	
Software Version	05.70	
Unit Tag	FCU-5901L, FCU-5901M, FCU-5901N, FCU-5901P, FCU-5901Q, FCU-5901R, FCU-5901S, FCU-5901T, FCU-5901U, FCU-5901V	



Unit Overview				
Model Number	Voltage V/Hz/Phase	Airflow CFM	External Static Pressure inH ₂ O	Design Cooling Capacity Btu/hr
BCHE0301	460/60/3	1700	1.00	40416

Unit	
Model Number:	BCHE0301
Unit Arrangement:	Horizontal
Altitude:	705 ft

Physical			
Dimensions and Weight (wet)			
Length	Height	Width	Weight
40 in	26.0 in	49.0 in	543 lb
Construction			
Insulation and Liners:	1" Injected Foam, R-6, Galvanized Steel Liner		

Electrical			
Field Connection	M CA	M ROPD	SCCR
Toggle Disconnect Switch	7.0	15	5 kA

Filter			
Filter Access	Filter Depth	M ERV Rating	(Quantity) Height x Width x Depth
Bottom	2 in	MERV 13	(2) 25.38 x 21.88

Primary Hydronic Coil					
Physical					
Fins per Inch	Rows	Casing Material	Face Area ft ²	Face Velocity ft/min	
16	2	Stainless Steel	6.0	281.7	
Connection					
Size	Type		Location		
1.12	F-SWT		Left Hand		
Drain Pan					
Material		Connection			
Stainless Steel		0.75 in			
Performance					
Capacity		Air Temperature			
Total Btu/hr	Sensible Btu/hr	Entering		Leaving	
		Dry Bulb °F	Wet Bulb °F	Dry Bulb °F	Wet Bulb °F
40416	36032	72.0	60.0	52.1	51.3

Fluid				
Type	Entering Temperature °F	Leaving Temperature °F	Flow Rate gpm	Pressure Drop ft H ₂ O
Water	42.0	49.6	10.6	3.36

Secondary Hydronic Coil

Physical				
Fins per Inch	Rows	Casing Material	Face Area ft ²	Face Velocity ft/min
12	1	Stainless Steel	6.0	281.7
Connection				
Size	Type	Location		
0.62	F-SWT	Left Hand		
Performance				
Total Btu/hr	Air Temperature			
	Dry Bulb °F			Dry Bulb °F
45392	60.0			85.1
Fluid				
Type	Entering Temperature °F	Leaving Temperature °F	Flow Rate gpm	Pressure Drop ft H ₂ O
Water	130.0	102.1	3.3	1.35

Supply Fan

Performance							
Airflow	Total Static Pressure	Fan Speed	Controller Input Signal	Brake Horsepower	Total Input Power	Fan Energy Index	Altitude
1700	1.87 inH ₂ O	1933 rpm	6.1 VDC	0.72 HP	0.85 HP	1.793	705 ft
Motor							
Type	Horsepower	Motor Control				FLA	
Premium Efficiency	4.42 Hp	0-10V Modulating				5.6 A	

Unit Discharge Conditions

Air Temperature			
Motor Heat Btu/hr	Unit Leaving Dry Bulb °F	Unit Leaving Wet Bulb °F	Unit Leaving Dewpoint °F
2599	53.5	51.8	50.5

Internal Pressure Drop Calculation

External Static Pressure:	1.00 inH ₂ O
Filter:	0.19 inH ₂ O
Dirty Filter:	0.50 inH ₂ O
Chilled Water Coil:	0.14 inH ₂ O
Hot Water Heat:	0.05 inH ₂ O
Total Static Pressure:	1.87 inH₂O

Options

Controls	
Overflow Switch:	Factory mounted Overflow Switch

Warranty

Parts: Standard warranty

AHRI Certification



All equipment is rated and certified in accordance with AHRI 430.

Notes

Daikin Air Handler Packaged Fan Selection

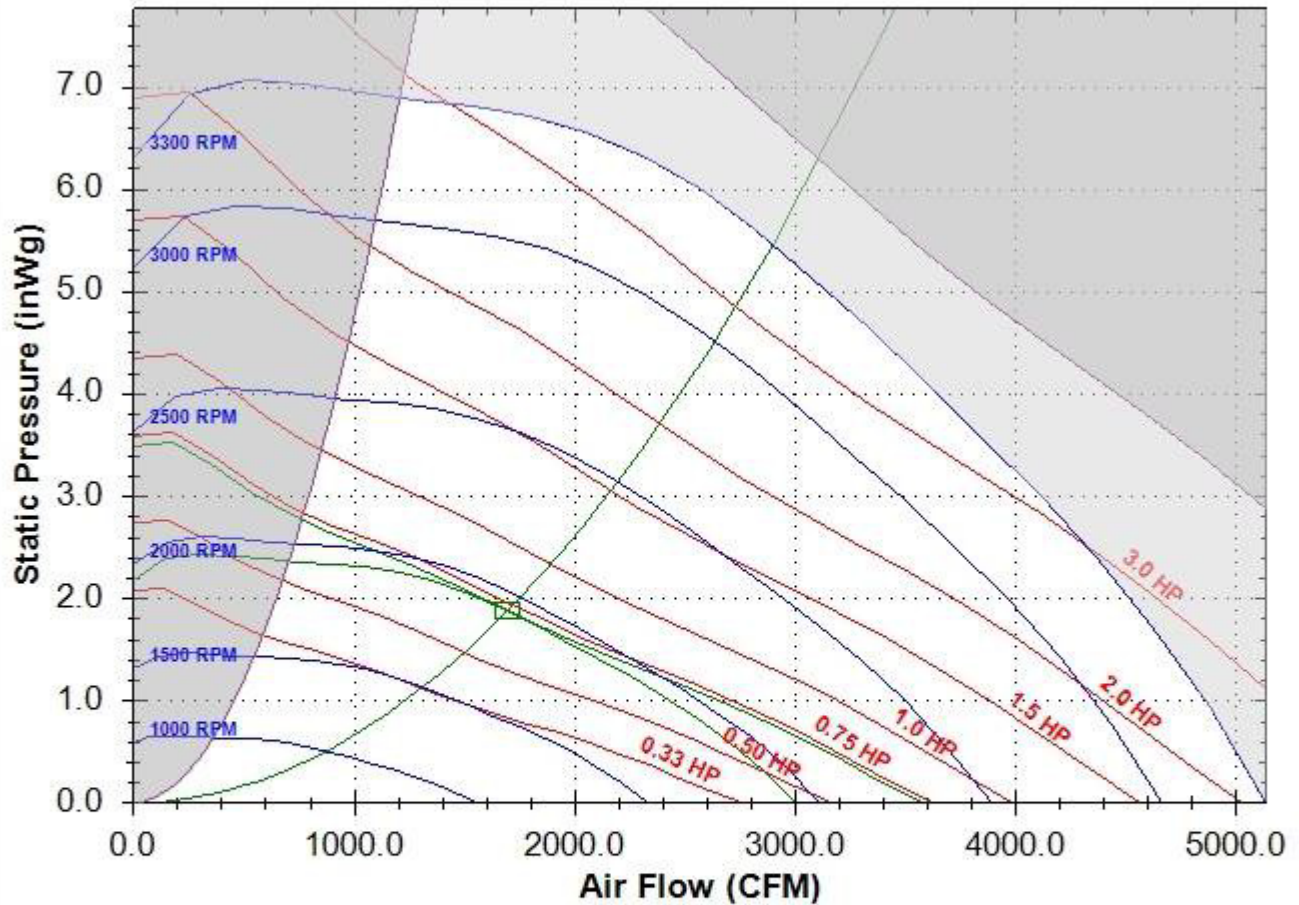

355.0 SWSI_AF Supply Fan at 705 ft Altitude

Base Tag	FCU-5901L thru FCU-5901V		Date	Apr-17-2023	
Job Name	ELI LILLY		Time	3:16 PM	
Air Volume	1700	CFM	Fan Speed	1933	RPM
Total Static	1.87	inWg	Max Speed	3300	RPM
Brake Horsepower	0.72	HP	Efficiency	69.5	%

SFONUE

ELI LILLY

21

4/17/2023

FCU-5901L thru FCU-5901V

Drawings(Clearance View)

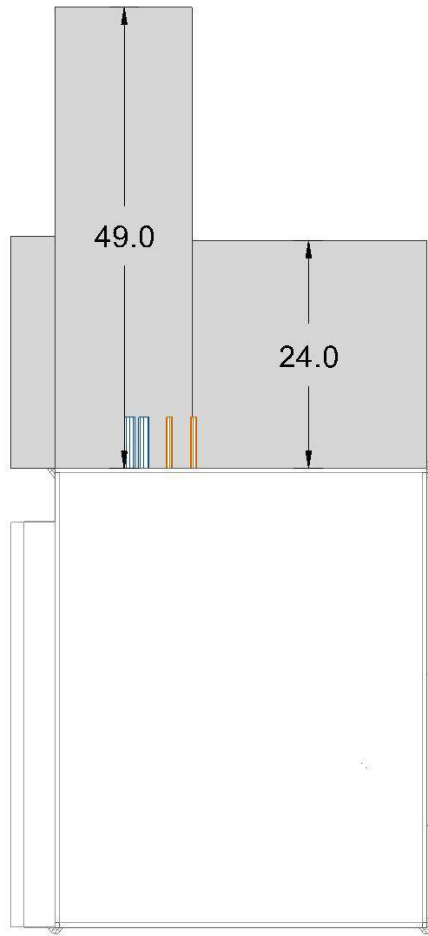

PLAN VIEW - SERVICE CLEARANCE

Clearance View		Unit Tag: FCU-5901L thru FCU-5901V			Sales Office: Hoffman & Hoffman, Inc.			 13600 Industrial Park Blvd. Minneapolis, MN 55441 www.DaikinApplied.com Software Version: 05.61
Product: PreciseLine® Air Handler		Project Name: ELI LILLY			Sales Engineer:			
Model: BCHE0301		Mar. 06, 2023	Ver/Rev:	Sheet: 1 of 1	Scale: NTS	Tolerance: +/- 0.25"	Dwg Units: in [mm]	

No change to this drawing may be made unless approved in writing by Daikin Applied. Purchaser must determine that the equipment is fit and sufficient for the job specifications.

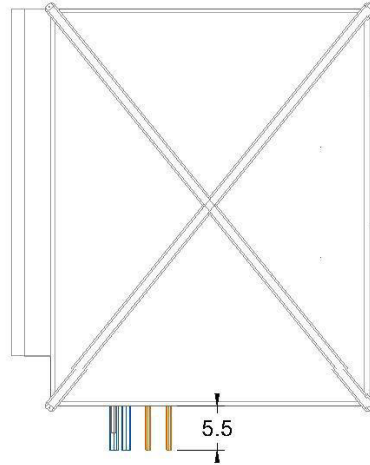

BOTTOM VIEW

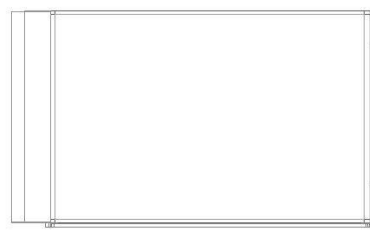

BACK VIEW

SFONUUE

ELI LILLY

22

4/17/2023

Front Bottom		Unit Tag: FCU-5901L thru FCU-5901V			Sales Office: Hoffman & Hoffman, Inc.			 13600 Industrial Park Blvd. Minneapolis, MN 55441 www.DaikinApplied.com Software Version: 05.61
Product: PreciseLine® Air Handler		Project Name: ELI LILLY			Sales Engineer:			
Model: BCHE0301	Mar. 06, 2023	Ver/Rev:	Sheet: 1 of 1	Scale: NTS	Tolerance: +/- 0.25"	Dwg Units: in [mm]		

No change to this drawing may be made unless approved in writing by Daikin Applied. Purchaser must determine that the equipment is fit and sufficient for the job specifications.

SFONUUE

ELI LILLY

23

4/17/2023

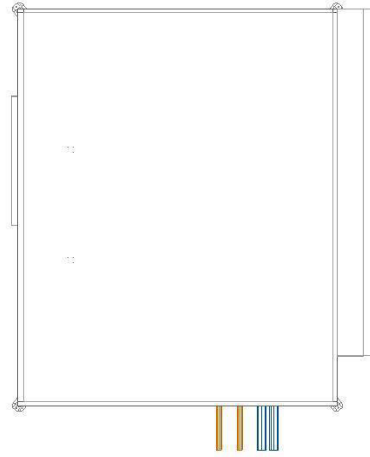

TOP VIEW

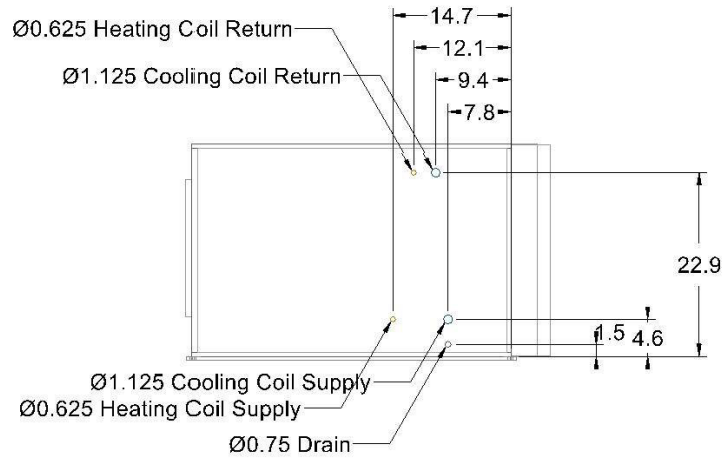

FRONT VIEW

FCU-5901L thru FCU-5901V

Drawings(Top Back)

Top Back		Unit Tag: FCU-5901L thru FCU-5901V			Sales Office: Hoffman & Hoffman, Inc.			 13600 Industrial Park Blvd. Minneapolis, MN 55441 www.DaikinApplied.com Software Version: 05.61
Product: PreciseLine® Air Handler		Project Name: ELI LILLY			Sales Engineer:			
Model: BCHE0301	Mar. 06, 2023	Ver/Rev:	Sheet: 1 of 1	Scale: NTS	Tolerance: +/- 0.25"	Dwg Units: in [mm]		

No change to this drawing may be made unless approved in writing by Daikin Applied. Purchaser must determine that the equipment is fit and sufficient for the job specifications.

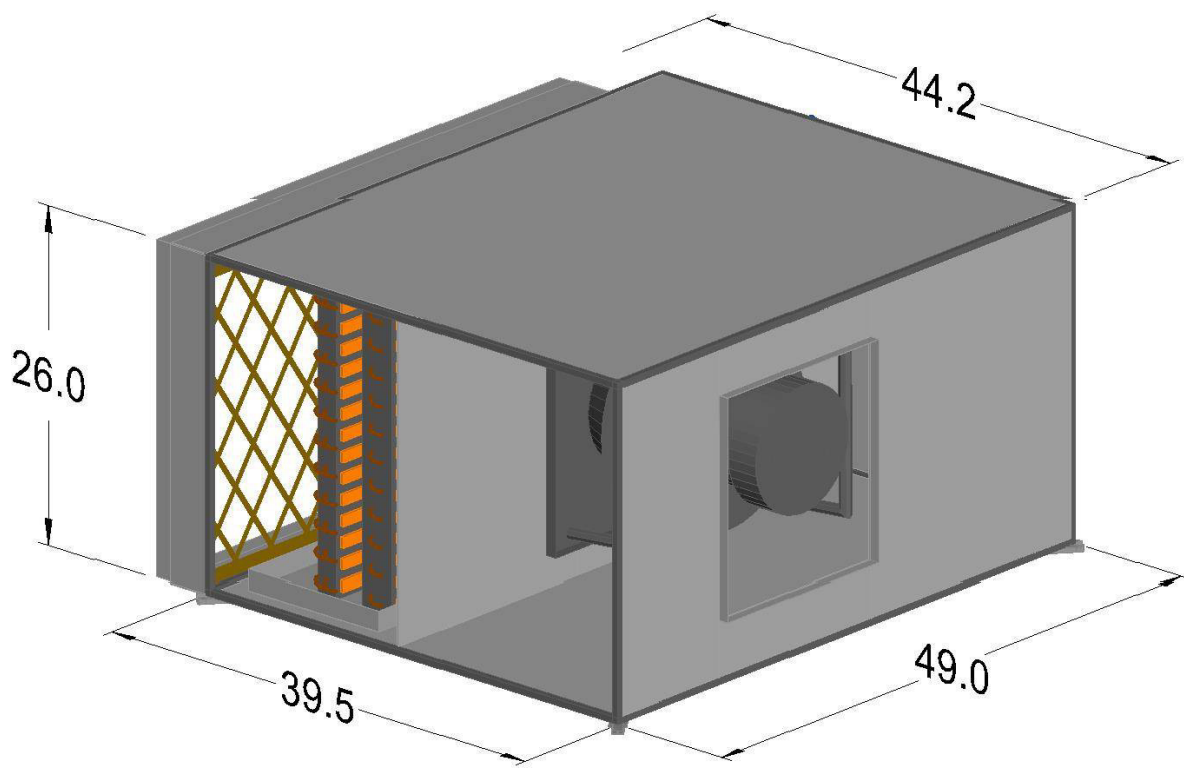

SFONUE

ELI LILLY

24

4/17/2023

FCU-5901L thru FCU-5901V

Preciseline Drawings

Product: PreciseLine® Air Handler		Unit Tag: FCU-5901L thru FCU-5901V		Sales Office: Hoffman & Hoffman, Inc.			 13600 Industrial Park Blvd. Minneapolis, MN 55441 www.DaikinApplied.com Software Version: 05.70
Model: BCHE0301		Project Name: ELI LILLY		Sales Engineer:			
Apr. 17, 2023	Ver/Rev:	Sheet: 1 of 1	Scale: NTS	Tolerance: +/- 0.25"	Dwg Units: in [mm]		

No change to this drawing may be made unless approved in writing by Daikin Applied. Purchaser must determine that the equipment is fit and sufficient for the job specifications.

SFONUE

ELI LILLY

25

4/17/2023

FCU-5901L thru FCU-5901V

Preciseline Drawings

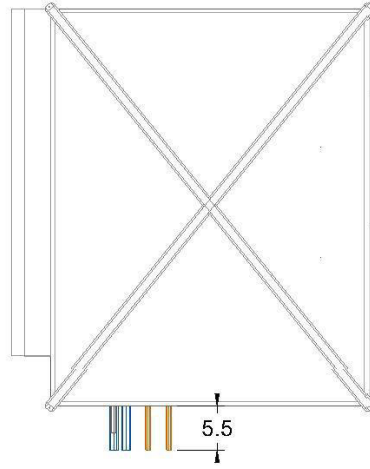

BOTTOM VIEW

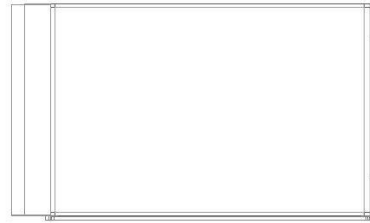

BACK VIEW

Product: PreciseLine® Air Handler		Unit Tag: FCU-5901L thru FCU-5901V		Sales Office: Hoffman & Hoffman, Inc.			 13600 Industrial Park Blvd. Minneapolis, MN 55441 www.DaikinApplied.com Software Version: 05.70
Model: BCHE0301		Project Name: ELI LILLY		Sales Engineer:			
Apr. 17, 2023	Ver/Rev:	Sheet: 1 of 1	Scale: NTS	Tolerance: +/- 0.25"	Dwg Units: in [mm]		

No change to this drawing may be made unless approved in writing by Daikin Applied. Purchaser must determine that the equipment is fit and sufficient for the job specifications.

SFONUE

ELI LILLY

26

4/17/2023

FCU-5901L thru FCU-5901V

Preciseline Drawings

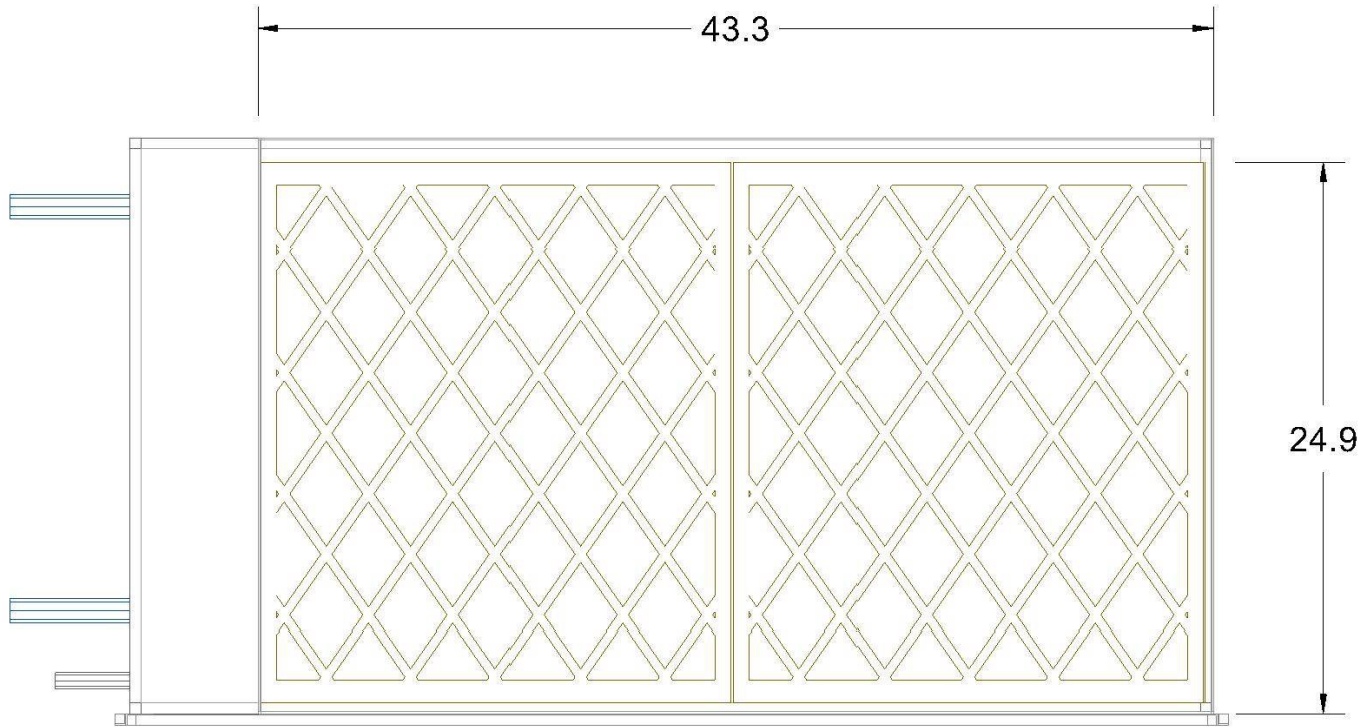

RIGHT VIEW

Product: PreciseLine® Air Handler		Unit Tag: FCU-5901L thru FCU-5901V		Sales Office: Hoffman & Hoffman, Inc.			 13600 Industrial Park Blvd. Minneapolis, MN 55441 www.DaikinApplied.com Software Version: 05.70
Model: BCHE0301		Project Name: ELI LILLY		Sales Engineer:			
Apr. 17, 2023	Ver/Rev:	Sheet: 1 of 1	Scale: NTS	Tolerance: +/- 0.25"	Dwg Units: in [mm]		

No change to this drawing may be made unless approved in writing by Daikin Applied. Purchaser must determine that the equipment is fit and sufficient for the job specifications.

SFONUE

ELI LILLY

27

4/17/2023



FCU-5901L thru FCU-5901V

Preciseline Drawings

Product: PreciseLine® Air Handler		Unit Tag: FCU-5901L thru FCU-5901V		Sales Office: Hoffman & Hoffman, Inc.			 13600 Industrial Park Blvd. Minneapolis, MN 55441 www.DaikinApplied.com Software Version: 05.70
Model: BCHE0301		Project Name: ELI LILLY		Sales Engineer:			
Apr. 17, 2023	Ver/Rev:	Sheet: 1 of 1	Scale: NTS	Tolerance: +/- 0.25"	Dwg Units: in [mm]		

No change to this drawing may be made unless approved in writing by Daikin Applied. Purchaser must determine that the equipment is fit and sufficient for the job specifications.

SFONUUE

ELI LILLY

28

4/17/2023

FCU-5901L thru FCU-5901V

Preciseline Drawings

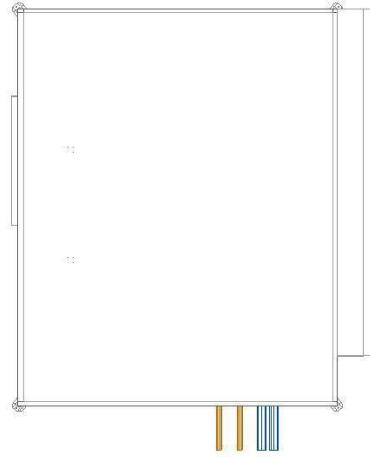

TOP VIEW

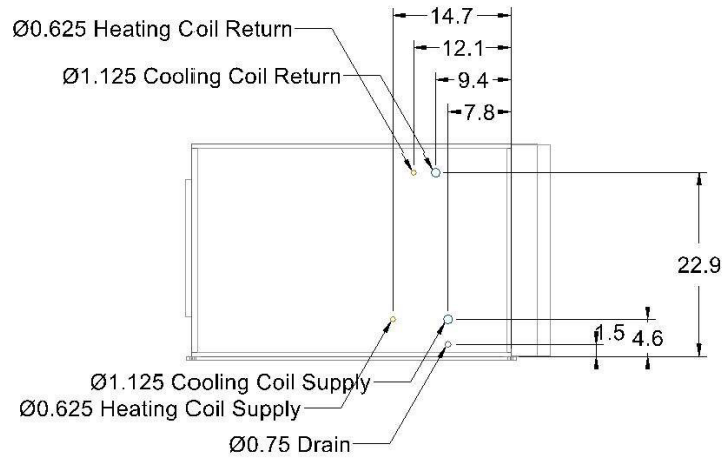

FRONT VIEW

Product: PreciseLine® Air Handler		Unit Tag: FCU-5901L thru FCU-5901V		Sales Office: Hoffman & Hoffman, Inc.			 13600 Industrial Park Blvd. Minneapolis, MN 55441 www.DaikinApplied.com Software Version: 05.70
Model: BCHE0301		Project Name: ELI LILLY		Sales Engineer:			
Apr. 17, 2023	Ver/Rev:	Sheet: 1 of 1	Scale: NTS	Tolerance: +/- 0.25"	Dwg Units: in [mm]		

No change to this drawing may be made unless approved in writing by Daikin Applied. Purchaser must determine that the equipment is fit and sufficient for the job specifications.

SFONUE

ELI LILLY

29

4/17/2023

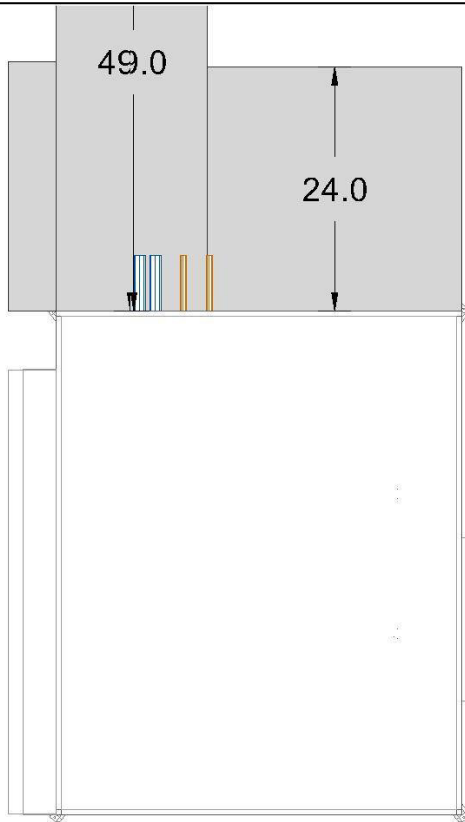

Plan View - Service Clearance

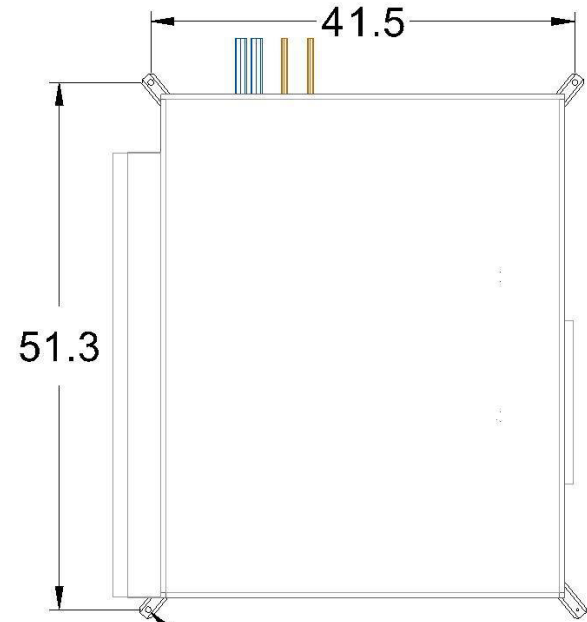

Plan View - Mounting

FCU-5901L thru FCU-5901V

Preciseline Drawings

Product: PreciseLine® Air Handler		Unit Tag: FCU-5901L thru FCU-5901V		Sales Office: Hoffman & Hoffman, Inc.			 13600 Industrial Park Blvd. Minneapolis, MN 55441 www.DaikinApplied.com Software Version: 05.70
Model: BCHE0301		Project Name: ELI LILLY		Sales Engineer:			
Apr. 17, 2023	Ver/Rev:	Sheet: 1 of 1	Scale: NTS	Tolerance: +/- 0.25"	Dwg Units: in [mm]		

No change to this drawing may be made unless approved in writing by Daikin Applied. Purchaser must determine that the equipment is fit and sufficient for the job specifications.