



**HIPP
DESIGN +
CONSULTING**

SHOP DRAWING / SUBMITTAL ACTION TICKET

CLIENT NAME	Eli Lilly
CONSTRUCTION MANAGER	BE&K
PROJECT NAME	Project Concord DAP
PROJECT NUMBER	G22131

SUBMITTAL NUMBER: #094		SUBMITTAL TITLE: Computer Room AC Units Rev 1	
CONTRACTOR / VENDOR: Kirlin-Way Mechanical		DATE RECEIVED: 12JUN2023	
RECEIVED BY: NR		DATE DUE: 28JUN2023	
DISPOSITION: <input checked="" type="checkbox"/> NO EXCEPTION TAKEN <input type="checkbox"/> APPROVED AS NOTED <input type="checkbox"/> REVISE AND RESUBMIT <input type="checkbox"/> REJECTED, RESUBMIT <input type="checkbox"/> NOT REVIEWED		DISTRIBUTION: <input type="checkbox"/> CIVIL _____ <input type="checkbox"/> ARCHITECTURAL _____ <input type="checkbox"/> STRUCTURAL _____ <input checked="" type="checkbox"/> MECHANICAL <u>AJA</u> <input type="checkbox"/> PROCESS _____ <input type="checkbox"/> ELECTRICAL _____ <input type="checkbox"/> INST & CONT. _____ <input type="checkbox"/> PROJ. LEADER _____ <input type="checkbox"/> OTHER _____	

Checking is only for general conformance with the design concept of the project and general compliance with the information given in the contract documents. Any action shown is subject to the requirements of the plans and specifications. Contractor is responsible for dimensions which shall be confirmed and correlated at the job site; fabrication processes and techniques of construction, coordination of his work with that of all other trades, and the satisfactory performance of his work.

REMARKS:

Adam Anderson PE

 PRIMARY DISCIPLINE LEAD

Mechanical

 DISCIPLINE

6/26/2023

 DATE



BE&K Building Group
 710 Slater Rd, Suite 400
 Morrisville, North Carolina 27560
 P: (919) 781-0054

**Project: 306232 Lilly — DAP, Warehouse Interface, + Central
 Corridor Fit Out**
 1420 Concord Parkway South
 Concord, North Carolina 28027

Submittal #238123-3.1 - Computer room AC Units 238123 - Computer-Room Air-Conditioners

Revision	1	Submittal Manager	Kevin Lloyd (BE&K Building Group - Raleigh)
Status	Open	Date Created	May 17, 2023
Issue Date	May 17, 2023	Spec Section	238123 - Computer-Room Air-Conditioners
Responsible Contractor	Kirlin-Way Mechanical, LLC	Received From	Allen Boyer (Kirlin-Way Mechanical, LLC)
Received Date	Nov 10, 2022	Submit By	Nov 10, 2022
Final Due Date	May 29, 2023	Lead Time	
		Cost Code	
Location		Type	Product Data
Approvers	Jason Brindle (Kirlin-Way Mechanical, LLC), Jarred Goldsmith (Kirlin-Way Mechanical, LLC), Jonathon Ross (Kirlin-Way Mechanical, LLC), Dylan Driscoll (BE&K Building Group - Raleigh)		
Ball in Court	Jason Brindle (Kirlin-Way Mechanical, LLC), Jonathon Ross (Kirlin-Way Mechanical, LLC)		
Distribution	Alex Stone (Hipp Engineering & Consulting Inc), Natasha R (Hipp Engineering & Consulting Inc), Jason Brindle (Kirlin-Way Mechanical, LLC), Jonathon Ross (Kirlin-Way Mechanical, LLC)		
Description	Please explain why this was never revised.		

Submittal Workflow

Name	Sent Date	Due Date	Returned Date	Response	Attachments
General Information Attachments					
Jason Brindle	May 17, 2023	May 24, 2023		Pending	
Jarred Goldsmith	Jun 12, 2023	May 24, 2023	Jun 13, 2023	For Record Only	For Record - Eli Lilly Concord CRAC Submittal REV2.pdf (Current)
Jonathon Ross	May 17, 2023	May 24, 2023		Pending	
Dylan Driscoll		May 29, 2023		Pending	



133 Southcenter Ct #1000
Morrisville, NC 27560
919-789-9750
InsightUSA.com

SUBMITTAL

Wednesday, March 8, 2023

Project: Eli Lilly Concord

Mechanical Contractor: Kirlin Way

Mechanical Engineer: Hipp

Equipment: Computer Room AC Units

Insight Partners Contact: John Beaird
Email: jbeaird@insightusa.com
Cell: 919-441-8100

CRAC Units

- (2) Above Air - 15 Ton Downflow Indoor Unit w/ Remote Condenser | **Tags: FCU-4941B & FCU-4941C**
Dual Cooling w/ Chilled Water & DX Backup
480V/3PH | Indoor Unit MOCP: 50A | Outdoor Unit MOCP: 15A
ECM Supply Air (Fixed Speed) & Condenser Fans
Unit Mounted HMI w/ BACnet Card
1 Year Parts Warranty | 4 Year Extended Compressor Warranty
4" MERV 13 Filters | Remote Probe/Spot Type Water Leak Detection
- (1) Above Air - 18 Ton Ducted Return Upflow Indoor Unit w/ Remote Condenser | **Tag: FCU-4941A**
Dual Cooling w/ Chilled Water & DX Backup
480V/3PH | Indoor Unit MOCP: 50A | Outdoor Unit MOCP: 15A
ECM Supply Air (Fixed Speed) & Condenser Fans
Unit Mounted HMI w/ BACnet Card
1 Year Parts Warranty | 4 Year Extended Compressor Warranty
4" MERV 13 Filters | Remote Probe/Spot Type Water Leak Detection

Comments to Remarks:

Comment: Confirm CRAC Units are suitable for use on an impedance grounded (HRG) system.

Response: The Manufacture is not familiar with this system but the electrician looked at our electrical drawings and felt we would have not issues with our unit as it relates to the impedance grounded system.

Comment: Computer Room Units must comply with Lilly Section 16910.

Response: This spec section appears to apply to custom build skid packages as opposed to non-custom catalogue systems built with standard manufacture practices. We must take exception to this spec for some of the below noted, not limited to, spec items:

Supplying Source Coding and Configurations

Each unit shall be pre-piped and pre-wired such that the Owner needs only to connect utilities to form a complete functional and integrated system.

Instrumentation and control devices associated with the Supplier's package shall comply with the Owner's approved instrument list as found in SECTION 16922, INSTRUMENT DATASHEETS

Automatic on-off valves shall be pneumatically operated and controlled by solenoids with manual override capability

A disconnecting means shall be provided at the control panel for each individual instrument

Cross AC and low-level DC signals only at right angles

In general, wiring shall be installed in hot-dipped galvanized rigid steel conduit.

Comment: Each unit will be provided with a set of terminals for UPS power.

Response: This is not available from Above Air

Comment: Up-Flow 18 ton unit is listed as both front and rear return.

Response: The unit is rear ducted return and the type-O has been corrected.

Unit Tag	CRAC-4941 B,C	Project	Eli Lilly Concord
Evap Model, Qty (2)	MCE-053D-4-00000-EC-DC-DFB-2B	Engineer	Hipp/Kirlin-Way
Cond Model, Qty (2)	XPX-4-AA-VF1-D1B0	Contractor	Kirlin-Way Mechanical
Unit Type	15.0 Ton (Dual Circuit) Nom. MC ACU w/ Split Condenser	AboveAir Rep	Insight (John Beard)
		Date	6-Feb-23

Electrical Data

Evap Section Power	460-480/3/60
Evap Nameplate	36.2 FLA 39.2 MCA 50 MOP
Cond Section Power	460-480/3/60
Cond Nameplate	2.0 FLA 2.5 MCA 15 MOP

Design Ambient Conditions

Summer	95.0°F DB / 78.0°F WB
Winter	0.0°F DB

Design Space/Return Conditions

Cooling	72.0°F DB / 60.0°F WB
Heating	75.0°F DB

Supply Air Fan Data

Total Airflow Rate	9,000 cfm
Outdoor Airflow Rate	00 cfm OA / 0.0%
ESP / TSP	1.00 in w.g. / 2.27 in w.g.
Fan Type, Qty (2)	ECM Direct Drive BI Impeller
Motor kW / FLA (Each)	4.5 kW / 5.9 FLA
Fan Speed Control	Constant Speed

Cooling Coil Data

Back Up DX Coil

Gross Capacity	182.9 TMBh / 175.0 SMBh
Net Capacity	164.7 TMBh / 156.9 SMBh
Mixed EAT	72.0°F DB / 60.0°F WB
Coil LAT	54.1°F DB / 52.6°F WB
Condensate Flow	9.8 lb/hr
Face Area / Rows / FPI	19.6 ft ² / 3 / 12
Construction	Aluminum Finned, Copper Tube

Hot Gas Reheat Coil Data

Capacity	N/A
LAT (@ Max Output)	N/A
Face Area / Rows / FPI	N/A
Construction	N/A
Control	N/A

Compressor Data

Comp 1 Type	Scroll w/ Hot Gas Bypass
Comp 1 LRA / RLA	100.0 LRA / 12.2 RLA
Comp 2 Type	Fixed Speed Scroll
Comp 2 LRA / RLA	100.0 LRA / 12.2 RLA
Location	Evaporator Section
Refrigerant Type	R-410a

Condenser Data

Total Heat of Rej.	226.7 MBh
Coil Construction	Aluminum Finned, Copper Tube
Airflow	13,000 cfm @ 0.00 in w.g. ESP
Fan Type, Qty (2)	Axial Fan
Low Ambient Control	Variable Speed Fan (-20°F)
Motor HP / FLA (each)	1/3 HP / 1.0 FLA

Chilled Water Coil Data

Gross Capacity	193.3 TMBh / 179.2 SMBh
Net Capacity	175.2 TMBh / 161.0 SMBh
EAT / LAT	72.0°F / 53.7°F
EWT / LWT	42.0°F / 53.4°F
GPM @ Ft Hd	34.0 gpm @ 12.1 ft w.g.
Fluid Type	Water
Face Area / Rows / FPI	19.6 ft ² / 3 / 12
Construction	Aluminum Finned, Copper Tube
Control Valve	2-Way, Modulating (300 psig)
Control Valve Cv	TBD

Unit Mounted Heat Data

Type	N/A
Capacity / FLA	N/A
Operation	N/A
EAT / LAT	N/A
EWT / LWT	N/A
GPM @ Ft Hd	N/A
Fluid	N/A
Face Area / Rows / FPI	N/A
Construction	N/A
Control Valve	N/A
Control Valve Cv	N/A

Humidification Data

Type	N/A
Steam Capacity / FLA	N/A
Operation	N/A

Unit Configuration & Airflow Patterns

- **Downflow: Free or Ducted Top Return/Bottom Discharge**
- Bottom Piping Connections
- Remote Free Discharge Split Condenser
- No Plenum Box
- **18" High (Adj. 17.2"-20") Field Installed Floor Stand**

Refrigerant Field Connections

Indoor Unit (Qty 2 ea.) 1/2"OD Liq & 7/8" OD Discharge
Indoor HG Reheat N/A
Outdoor Unit (Qty 2 ea.) 1/2"OD Liq & 7/8" OD Discharge
Outdoor HG Reheat N/A

Connection Data

Condensate Drain 1" FPT
Humidifier Supply N/A
Hot Water N/A
Dual Cool 1 5/8" OD IN/OUT

Air Filtration Data

Filter Qty (1) 20x20x4 &
Qty (2) 20x25x4 &
Qty (1) 16x20x4 &
Qty (2) 16x25x4 (Merv 13)

Physical Data

Dimensions See attached cut sheet
Evap / Cond Weight 1650 lbs / 1350 lbs

Coil Coatings

- Supply Air Coils - No Coatings
- Condenser Coil - No Coatings

Factory Installed Optional Accessories

- Through-Door Main Power Disconnect (Evap Section)
- Condensate Pump

Field Installed Optional Accessories

- Water Detector (Probe/Spot Type)
- Non-Fused Disconnect (Cond Section)

Control Type

- MC-Series Advanced Microprocessor w/ Alarms

Control Sequence

- MC-2000S RT Std DX Temperature Only Control

Sensors & Displays

- Unit Mtd Human Machine Interface (HMI)
- Wall Mounted Temperature Sensor

Control Options

- BMS Card (BACnet IP)
- Multi-Unit Sequencing

Factory Warranties (Labor Not Included)

- 1 Year Limited Parts Warranty
- 4 Year Extended Compressor Warranty

Select Standard Design Features

- Heavy Duty Gavanneal Steel Construction
- High Efficiency Scroll Compressor
- TXV with External Equilization
- High & Low Refrigerant Pressure Safety Switches
- Stainless Steel Drain Pan with Overflow Safety Switch
- Intertek (ETL) UL STD 1995 Listed/Labeled
- Factory installed and tested controls
- Each unit factory tested per UL 1995 Requirements

System Notes

1. System ships with a dry nitrogen charge.
2. Do not install refrigerant piping based upon connection sizes. Refrigerant piping runs must be sized according to piping requirements at www.aboveairioms.com.
3. Max total equivalent line length is 150 feet.

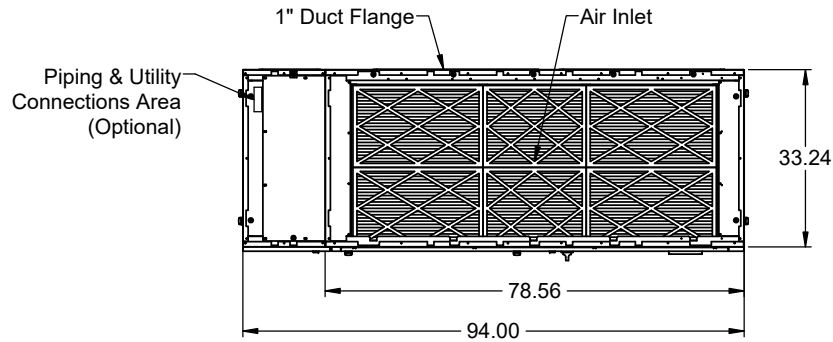

Top View

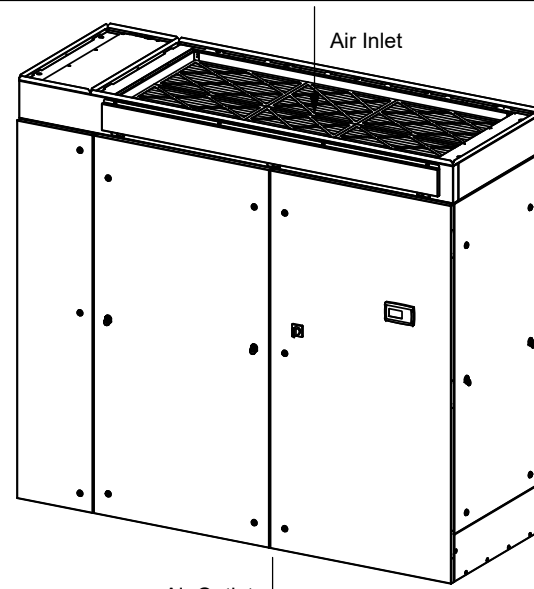

Air Outlet

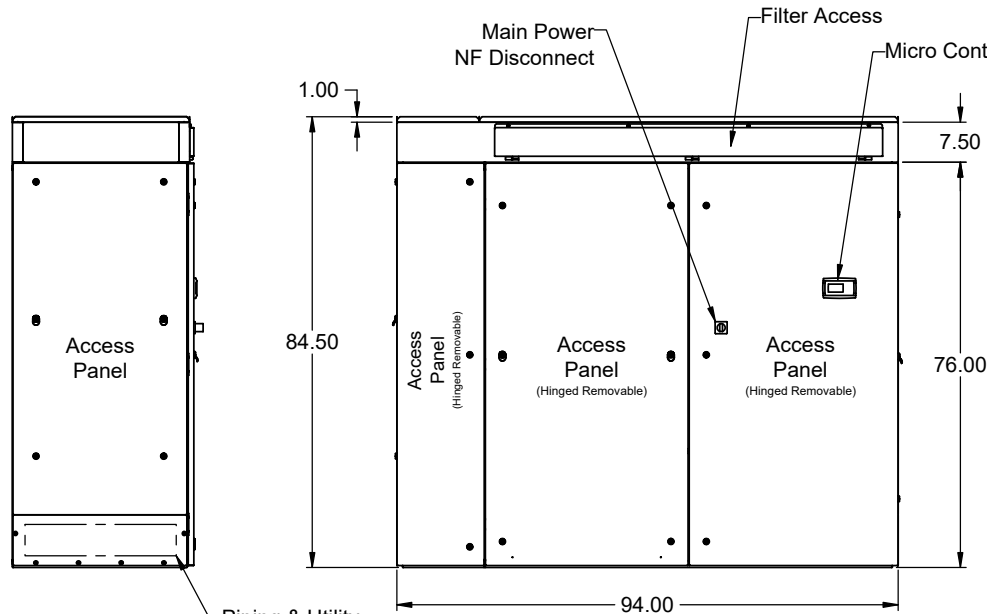

Front View

Left View

Piping & Utility Connections Area (Optional)

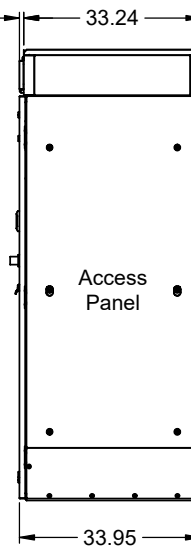

Right View

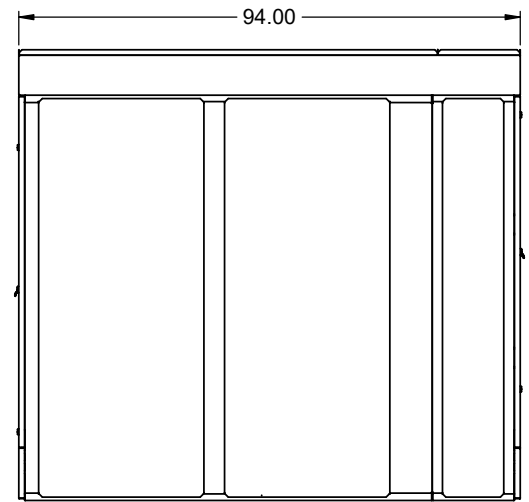

Rear View

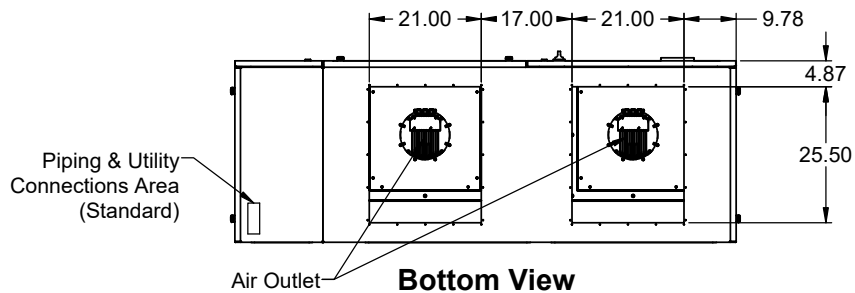

Bottom View

<p>Tel: (301) 874-1130</p>	Dwg No.	MD3410-2-V2-0001
	Date	12/6/22
Description		Rev
<p>MC2-DF-B Packaged BD V2</p>		B

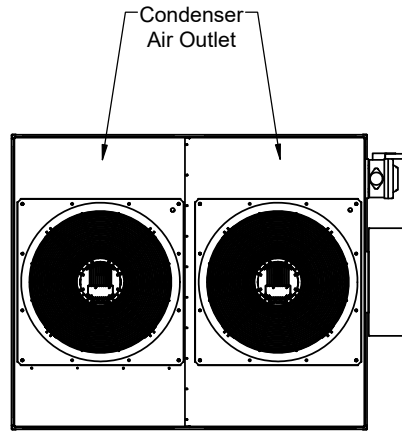

Top View

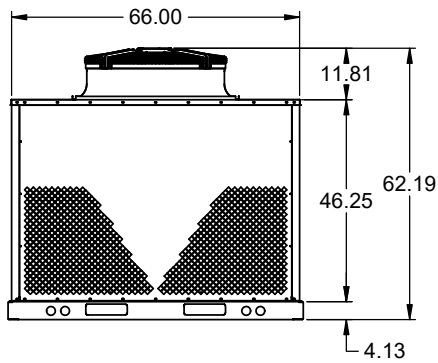
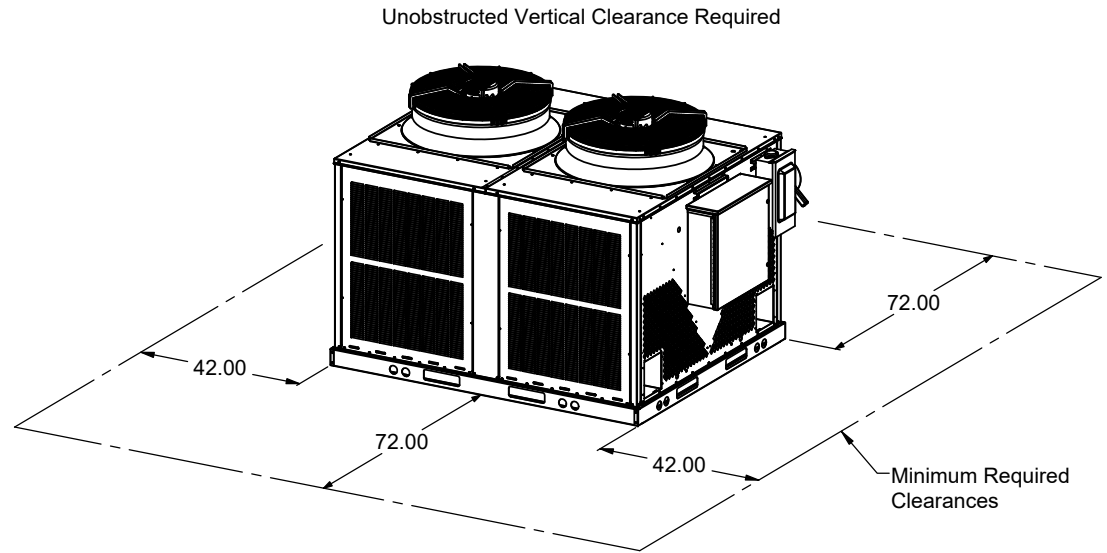

Left View

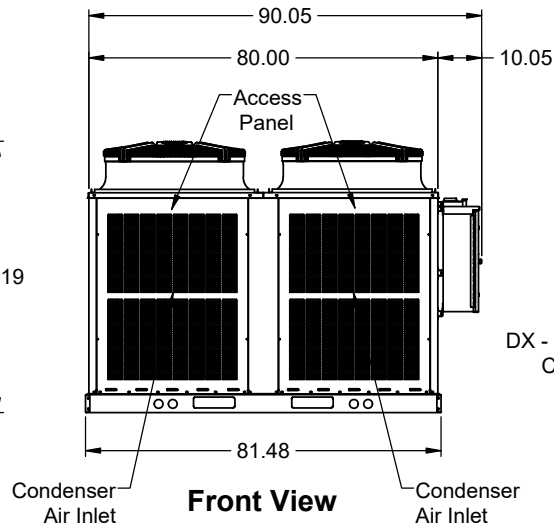

Front View

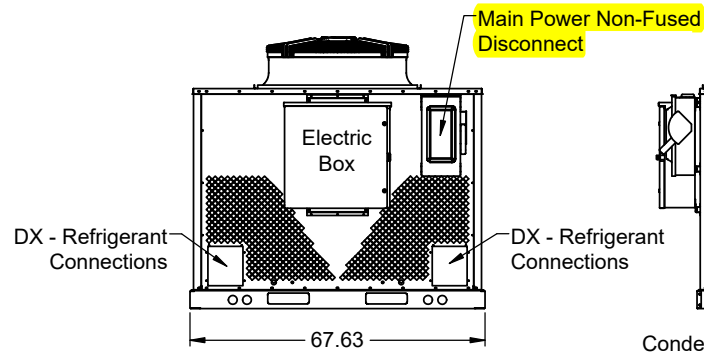

Right View

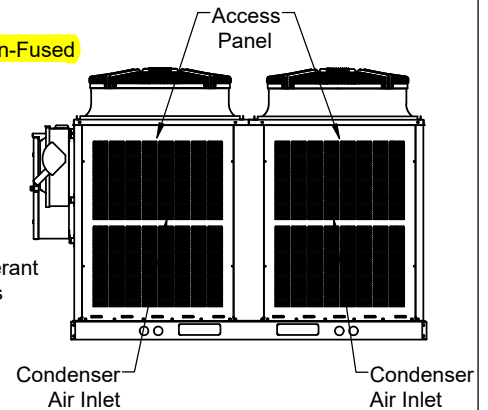

Rear View

<p>Tel: (301) 874-1130</p>	Dwg No.	MD3356-2-0001
	Date	11/1/22
Description		Rev
<p>XPU-XP2 12-20T (Dual Circuit) Twin EC Fans</p>		F

Unit Tag	FCU-4941A	Project	Eli Lilly Concord
Evap Model, Qty (1)	MCE-063D-4-0000-EC-DC-UFR-2C	Engineer	Hipp/Kirlin-Way
Cond Model, Qty (1)	XPX-4-AA-VF1-D1B0	Contractor	Kirlin-Way Mechanical
Unit Type	18.0 Ton (Dual Circuit) Nom. MC ACU w/ Split Condenser	AboveAir Rep	Insight (John Beard)
		Date	6-Feb-23

Electrical Data

Evap Section Power	460-480/3/60
Evap Nameplate	41.3 FLA 45.0 MCA 50 MOP
Cond Section Power	460-480/3/60
Cond Nameplate	2.0 FLA 2.5 MCA 15 MOP

Design Ambient Conditions

Summer	95.0°F DB / 78.0°F WB
Winter	0.0°F DB

Design Space/Return Conditions

Cooling	72.0°F DB / 60.0°F WB
Heating	75.0°F DB

Supply Air Fan Data

Total Airflow Rate	10,000 cfm
Outdoor Airflow Rate	00 cfm OA / 0.0%
ESP / TSP	0.75 in w.g. / 1.97 in w.g.
Fan Type, Qty (2)	ECM Direct Drive BI Impeller
Motor kW / FLA (Each)	4.5 kW / 5.9 FLA
Fan Speed Control	Constant Speed

Cooling Coil Data

Back Up DX Coil

Gross Capacity	225.9 TMBh / 207.8 SMBh
Net Capacity	208.3 TMBh / 190.3 SMBh
Mixed EAT	72.0°F DB / 60.0°F WB
Coil LAT	52.9°F DB / 51.7°F WB
Condensate Flow	19.6 lb/hr
Face Area / Rows / FPI	22.1 ft ² / 3 / 12
Construction	Aluminum Finned, Copper Tube

Hot Gas Reheat Coil Data

Capacity	N/A
LAT (@ Max Output)	N/A
Face Area / Rows / FPI	N/A
Construction	N/A
Control	N/A

Compressor Data

Comp 1 Type	Scroll w/ Hot Gas Bypass
Comp 1 LRA / RLA	130.0 LRA / 14.7 RLA
Comp 2 Type	Fixed Speed Scroll
Comp 2 LRA / RLA	130.0 LRA / 14.7 RLA
Location	Evaporator Section
Refrigerant Type	R-410a

Condenser Data

Total Heat of Rej.	282.4 MBh
Coil Construction	Aluminum Finned, Copper Tube
Airflow	13,000 cfm @ 0.00 in w.g. ESP
Fan Type, Qty (2)	Axial Fan
Low Ambient Control	Variable Speed Fan (-20°F)
Motor HP / FLA (each)	1/3 HP / 1.0 FLA

Chilled Water Coil Data

Gross Capacity	200.9 TMBh / 193.4 SMBh
Net Capacity	183.4 TMBh / 175.8 SMBh
EAT / LAT	72.0°F / 54.2°F
EWT / LWT	42.0°F / 55.6°F
GPM @ Ft Hd	29.6 gpm @ 9.7 ft w.g.
Fluid Type	Water
Face Area / Rows / FPI	22.1 ft ² / 3 / 12
Construction	Aluminum Finned, Copper Tube
Control Valve	2-Way, Modulating (300 psig)
Control Valve Cv	TBD

Unit Mounted Heat Data

Type	N/A
Capacity / FLA	N/A
Operation	N/A
EAT / LAT	N/A
EWT / LWT	N/A
GPM @ Ft Hd	N/A
Fluid	N/A
Face Area / Rows / FPI	N/A
Construction	N/A
Control Valve	N/A
Control Valve Cv	N/A

Humidification Data

Type	N/A
Steam Capacity / FLA	N/A
Operation	N/A

Unit Configuration & Airflow Patterns

- Upflow: **Rear Ducted Return**/Top Ducted Discharge
- Top Piping Connections
- Remote Free Discharge Split Condenser
- No Plenum Box
- No Floor Stand

Refrigerant Field Connections

Indoor Unit (Qty 2 ea.) 1/2"OD Liq & 1 3/8" OD Discharge
Indoor HG Reheat N/A
Outdoor Unit (Qty 2 ea.) 1/2"OD Liq & 1 3/8" OD Discharge
Outdoor HG Reheat N/A

Connection Data

Condensate Drain 1" FPT
Humidifier Supply N/A
Hot Water N/A
Dual Cool 1 5/8" OD IN/OUT

Air Filtration Data

Filter Qty (4) 20x20x4 &
Qty (4) 16x20x4 (Merv 13)

Physical Data

Dimensions See attached cut sheet
Evap / Cond Weight 1850 lbs / 1350 lbs

Coil Coatings

- Supply Air Coils - No Coatings
- Condenser Coil - No Coatings

Factory Installed Optional Accessories

- Through-Door Main Power Disconnect (Evap Section)
- Condensate Pump
- Non-Fused Disconnect (Cond Section)

Field Installed Optional Accessories

- Water Detector (Probe/Spot Type)

Control Type

- MC-Series Advanced Microprocessor w/ Alarms

Control Sequence

- MC-2000S RT Std DX Temperature Only Control

Sensors & Displays

- Unit Mtd Human Machine Interface (HMI)
- Wall Mounted Temperature Sensor

Control Options

- BMS Card (BACnet IP)
- Multi-Unit Sequencing

Factory Warranties (Labor Not Included)

- 1 Year Limited Parts Warranty
- 4 Year Extended Compressor Warranty

Select Standard Design Features

- Heavy Duty Gavanneal Steel Construction
- High Efficiency Scroll Compressor
- TXV with External Equilization
- High & Low Refrigerant Pressure Safety Switches
- Stainless Steel Drain Pan with Overflow Safety Switch
- Intertek (ETL) UL STD 1995 Listed/Labeled
- Factory installed and tested controls
- Each unit factory tested per UL 1995 Requirements

System Notes

1. System ships with a dry nitrogen charge.
2. Do not install refrigerant piping based upon connection sizes. Refrigerant piping runs must be sized according to piping requirements at www.aboveairioms.com.
3. Max total equivalent line length is 150 feet.

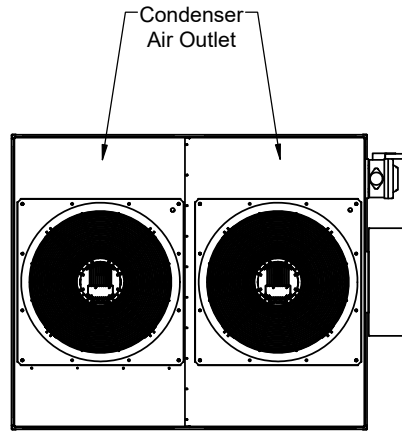

Top View

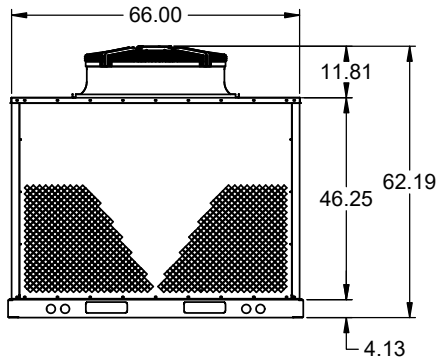
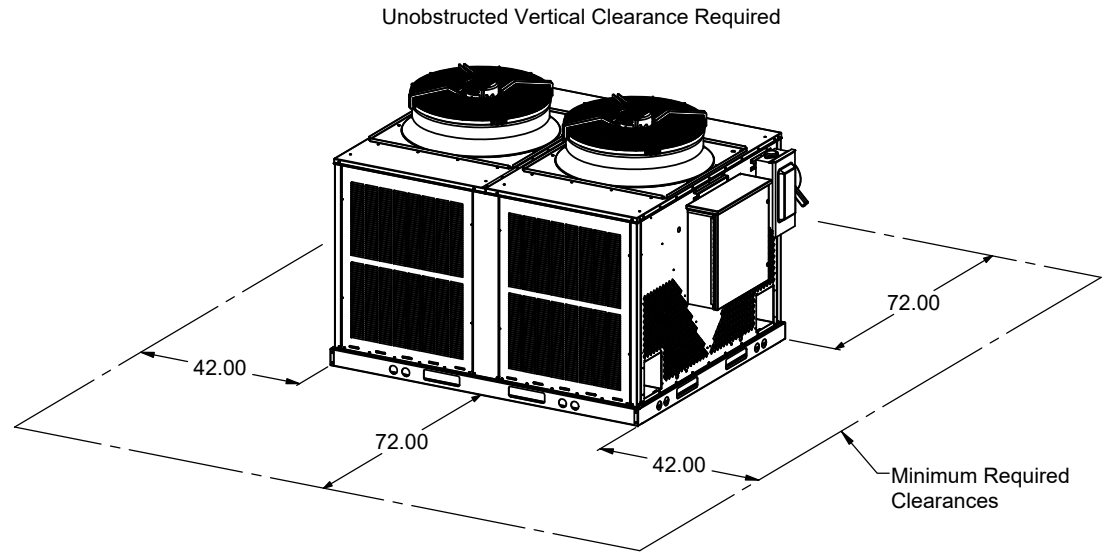

Left View

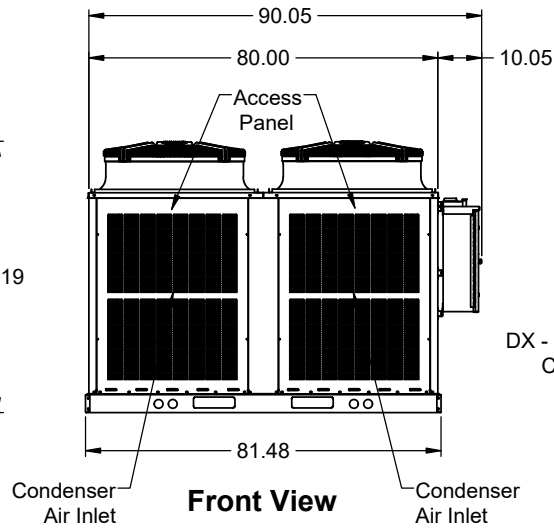

Front View

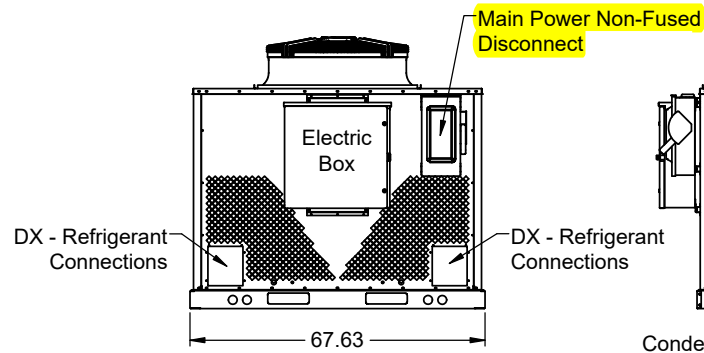

Right View

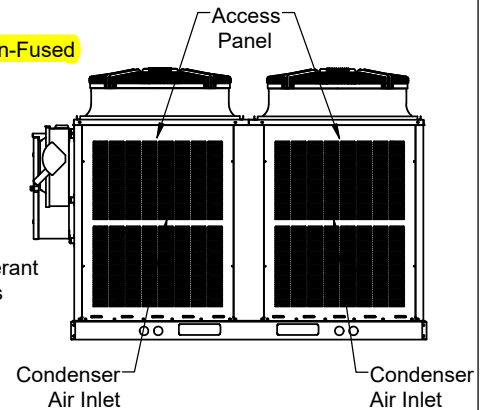

Rear View

<p>Tel: (301) 874-1130</p>	Dwg No.	MD3356-2-0001
	Date	11/1/22
Description		Rev
<p>XPU-XP2 12-20T (Dual Circuit) Twin EC Fans</p>		F

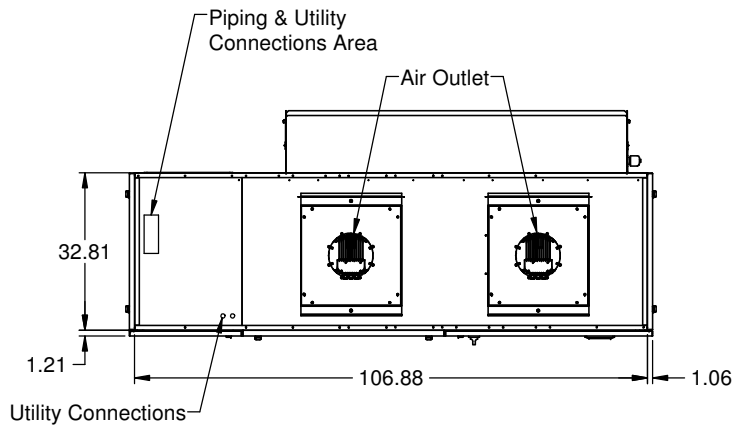

Top View

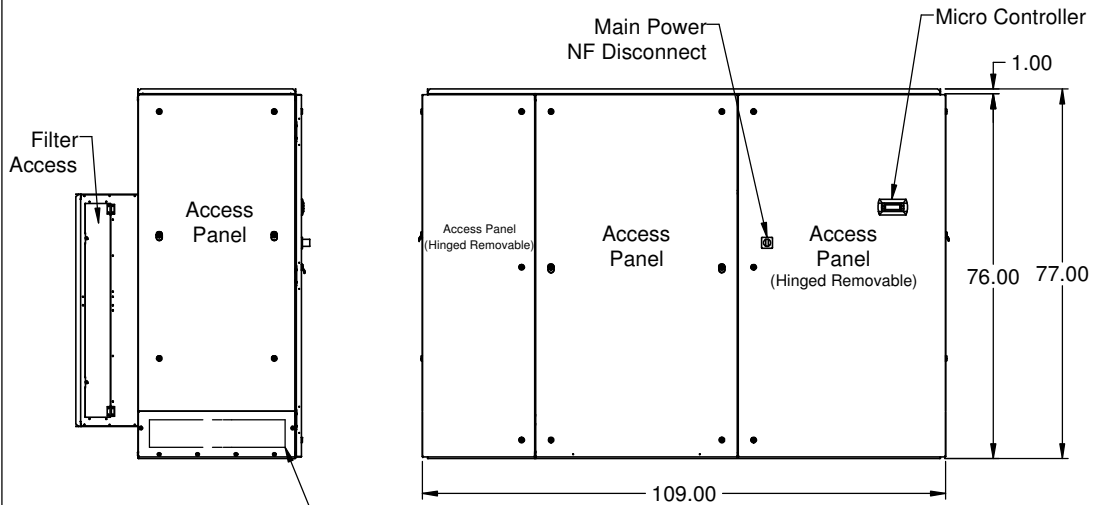
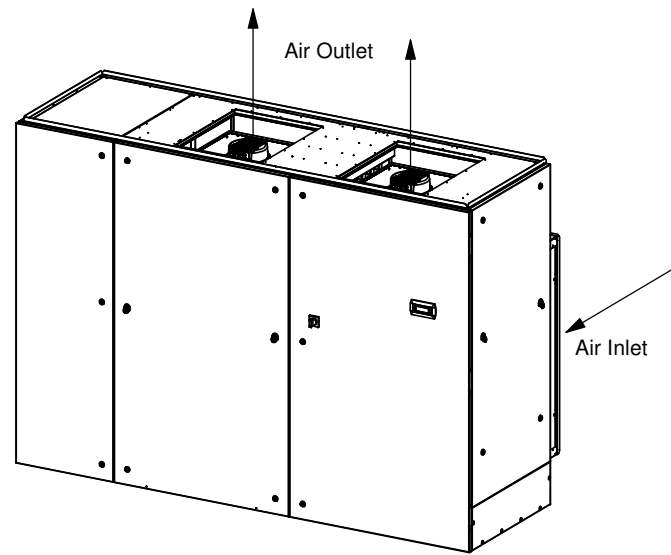

Left View

Front View

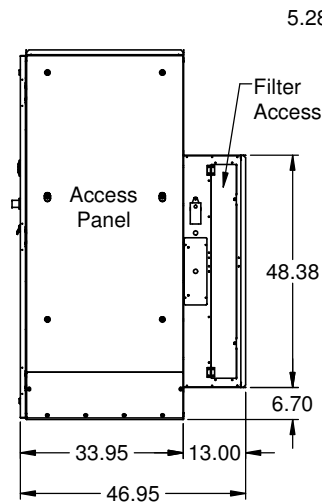

Right View

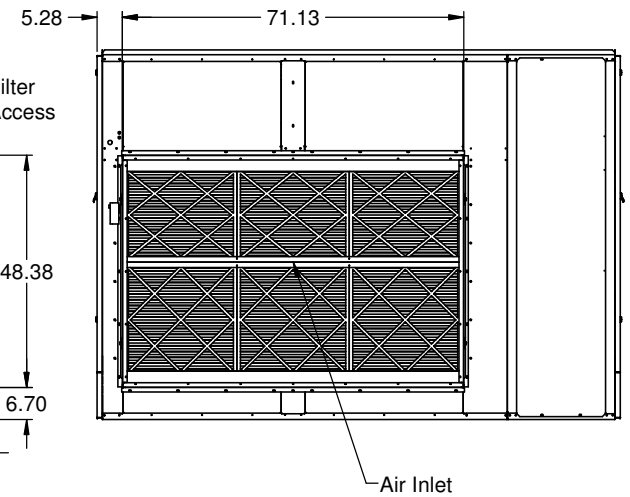

Rear View

	Dwg No.	MD3402-3-V2-0007
	Date	3/28/20
Tel: (301) 874-1130	Rev	-
Description		
MC2-UF-C Packaged Ducted RR V2_Flat		

General

Summary



These specifications describe the requirements for a vertical floor mounted packaged (or split) precision air conditioner. The system shall be designed to control space temperature and humidity.

The air conditioning manufacturer shall design and furnish all equipment in the quantities and configurations shown on the project plans and specifications.

The system shall be provided by AboveAir Technologies in Frederick, Maryland, USA. The system shall be listed by Intertek (ETL Semko), Inc. to conform with UL Std 1995 and be certified to CAN/CSA Std C22.2 No. 236 (Control No. 3091370). The system shall be NYC MEA229-06-E and Chicago Code Approved. The system model number shall be _____.

Design Requirements

The system shall be an AboveAir Technologies MissionCritical™ brand, factory assembled and tested. The system shall be designed for indoor installation.

The system shall have a total cooling capacity of _____ BTU/H, and a sensible cooling capacity of _____ BTU/H, based on an entering air condition of _____ °F DB, and _____ °F WB, _____ % RH.

The evaporator section shall be designed for _____ Volt, _____ Phase, _____ Hertz main power supply. The remote condensing unit section (if applicable) shall be designed for _____ Volt, _____ Phase, _____ Hertz main power supply.

Submittals

Submittals shall be provided after manufacturer's receipt of a written purchase order and shall include: Detailed Performance and Electrical Data; Guide Specifications; and Dimensional Drawings.

Quality Assurance

The system shall be factory run tested prior to shipment. Testing shall include, but shall not be limited to: "HiPot" Test (2 times rated voltage plus 1000 volts, per UL 1995 testing requirements). The system shall be designed and manufactured according to world class quality standards.

Products

Standard Features

Cabinet

The cabinet chassis and access panels shall be powder-coat painted heavy gauge galvanneal steel for decor matching and corrosion resistance. Cabinet access panels shall rest in recessed pockets designed for minimum air leakage. The cabinet and access panels shall be lined with 2 lb/ft² high density sound and thermal insulation and sealed with self-extinguishing gasketing conforming to NFPA 90A and 90B.

Component Access

The unit shall be serviceable through front and side (as required) access panels with quick-release quarter-turn fasteners.

Electrical System

General:

The electrical system shall conform to National Electric Code (NEC) requirements according to UL 1995. The control circuit shall be a 24 VAC low voltage circuit.

The electrical system shall include, but not be limited to the following factory installed items: main power distribution block; grounding lug; 24 VAC control transformer; terminal connections; and motor controllers with start protection and circuit breakers for blower motors, compressors and each electric heater stage (if applicable).

Packaged Systems: (single point power) Self-Contained systems shall be designed for single point main power connection.

Split DX Systems: (separate power) Split systems shall require separate main power supplies to the evaporator and condensing unit sections. The evaporator and condensing unit sections shall be electrically interlocked by a field wired 24 volt control signal.

Overflow Safety Float Switch:

The system shall be provided with a factory installed float type condensate overflow safety switch. The circuit shall be designed to shut down all system water producing operations in the event of an overflow condition.

Main Power, Disconnect

(MC_ Evap Section)



The indoor evaporator section shall be provided with a factory installed main power non-fused disconnect. The disconnect shall be NEMA rated for indoor or outdoor installation as required.

Air Distribution

Evap Blower/Motor



The evaporator blower assembly shall be a backward-inclined direct-drive centrifugal impeller with variable speed EC (electronically commutated) motor. The blower shall be designed for _____ CFM @ _____ inches external static pressure (e.s.p.)

Variety of Air Patterns



Up-Flow (UF) Down-Flow (DF)

Up-Flow Air Pattern:

UF*: Front-Free Return

The system shall be configured for up-flow evaporator air pattern with front-free return and top discharge. (Refer to Plenum Discharge Box Options.)

UR*: Rear-Ducted Return

The system shall be configured for up-flow evaporator air pattern with rear ducted return and top discharge.

Down-Flow Air Pattern:

DFFB: Bottom Disch Into Raised Floor

The system shall be configured for down-flow evaporator air pattern with top free or ducted return and bottom discharge into raised floor. (Refer to Floor Stand Options.)

DFF: Front Discharge Floor Level

The system shall be configured for down-flow evaporator air pattern with top free or ducted return and front free discharge to floor level.

Air Filtration



The return air filters shall be 4 inch thick pleated and Merv-8 efficiency rated (based on ASHRAE 52.2). The filters shall be serviceable without shutting down the system.

Piping Connection Location

- Top Piping Connections
- Lower-Side Piping Connections
- Bottom Piping Connections

Direct Expansion Systems

DX - Evaporator Coil



The DX evaporator coil shall be constructed of copper tubes and aluminum fins. The system shall be designed for a draw-through air pattern for maximum heat transfer. Coil end-plates shall be hot dipped galvanized. The evaporator coil shall be mounted in an insulated stainless steel condensate drain pan.

Dual Scroll Compressors



Each compressor shall be the high efficiency, low sound Scroll type mounted

on vibration isolators and located in a separate compartment out of the evaporator air stream to facilitate servicing while equipment is operating. Each compressor shall be complete with reversible positive oil pump, charging and service ports, internal spring isolation, and discharge gas vibration eliminator.

(Note: 2-Speed & Modulating Digital Scroll Compressors are optionally available!)

DX - Refrigeration Circuit



Each refrigeration circuit shall be pre-piped with type "L" refrigerant copper tubing. The refrigeration system shall include but not be limited to: expansion valve with external equalizer and rapid bleed-through capacity. Features shall include filter dryer, sight glass, pressure fittings and high pressure/low pressure safety cutouts.

Cooling Configurations

DX - Air Cooled Split

(Split Evap & Outdoor Remote Condenser) MCE-() & XPX-()



The system shall be a split configuration with compact indoor vertical floor mounted dx evaporator precision air conditioner with outdoor dx air cooled propeller fan remote condenser. The compressor shall be located in the indoor evaporator section. The condenser shall be sized for full heat of rejection at 95°F ambient and be capable of operation to ___ °F low ambient air temperature.

The system shall be refrigerant charged and run tested at the factory prior to shipment. The evaporator and condenser sections shall ship separately with a dry-nitrogen charge ready for field refrigerant charging.

DX - Water Cooled

(Self-Contained Systems) MCW-()

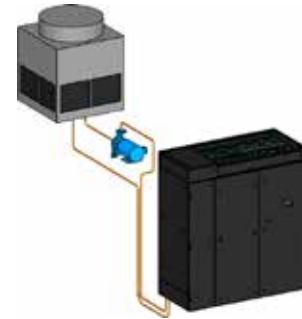

The system shall be a self-contained, compact indoor vertical floor mounted dx water cooled precision air conditioner. The system shall include a water cooled tube-in-tube coaxial condenser and factory installed head pressure controlling 2-way water regulating valve rated for 350 psi w.w.p. The water cooled condenser shall be designed to provide the total required system heat of rejection at 85°F entering water temperature and 95°F leaving water temperature. Source water shall be provided by a remote water source (by others).

The system shall require only single point main power supply and ship from the factory with a full operating refrigerant charge.

(Note: 3-Way and High Pressure valves are optionally available)

DX - Glycol Cooled

(Self-Contained Systems) MCG-()



The system shall be a self-contained, compact indoor vertical floor mounted dx glycol cooled precision air conditioner. The system shall include a glycol cooled tube-in-tube coaxial condenser and factory installed head pressure controlling 2-way glycol regulating valve rated for 350 psi w.w.p. The condenser shall be designed to provide the total required system heat of rejection at 110°F entering glycol temperature and 120°F leaving glycol temperature based on 40% ethylene glycol solution. Source glycol shall be provided by a remote glycol drycooler

source (see AboveAir Technologies' FluidCool™ drycoolers).

The system shall require only single point main power supply and shall ship from the factory with a full operating refrigerant charge.

(Note: 3-Way and High Pressure valves are optionally available)

(Note: See AboveAir Technologies' Fluid-Cool™ indoor & outdoor glycol drycooler and PumpAll™ glycol pump packages engineering manuals for more information.)

Free-Cooling w/ DX Water/Glycol Cooled - MCW & MCG-()-FE

The system shall include a factory installed water/glycol free cooling cycle complete with economizer cooling coil, 2 or 3-way modulating (0-10Vdc) control valve rated for 580 psig, aquastat sensor and automatic control logic. The FE coil shall be capable of providing rated sensible capacity without compressor operation when entering water/glycol fluid temperatures are 45°F or below (adjustable).

(Note: Free-Cool valve must match condenser water/glycol regulating valve 2 or 3-way.)

Dual-Cool, Chilled Water Coil & DX Cooling Cycle - MC_()-DC

The system shall be a Dual-Cool configuration with primary chilled water coil cooling cycle and back-up DX cooling cycle (DX Air, Water or Glycol Cooled as specified). Based on the available chilled water flow rate and temperature (45°F or below typical, adjustable), the unit's control system shall automatically select either chilled water or DX cooling modes. The system shall be provided with a factory installed 2 or 3-Way Modulating (0-10Vdc) chilled water control valve rated for 580 psig and field installed chilled water supply pipe temperature sensor.

Free-Cooling / Dual-Cool Coil Control Valves

Chilled Water Control Valves



Modulating Valves, 0-10Vdc:

- **2-Way, 580 psig (0-10Vdc, NC)**
- **3-Way, 580 psig (0-10Vdc, NC)**

A ___-way free-cooling (or dual cool) coil control valve shall be factory installed within the air conditioning unit. The valve shall provide precision space cooling and/or dehumidification control. The valve shall be the 24 VAC, ___-Way, Modulating (0-10Vdc), normally closed type.

Suction-Line Accumulators



Each refrigerant circuit shall be provided with a factory installed Suction-Line Accumulator to prevent liquid slugging of the compressor and excessive refrigerant dilution of the compressor oil during low load conditions. The accumulator shall return refrigerant and oil to the compressor at a sufficient rate to maintain both system operating efficiency and proper oil level. The accumulators shall be wrapped with 1/2" closed-cell neoprene insulation to prevent sweating.

CONTROL OPTIONS

MC-2000™, Advanced Temp/Humid Microprocessor Controller w/ Alarms & BMS Connection



The system shall be provided with a MC-2000™ advanced microprocessor based temperature and humidity controller with alarms.

Select Features/Benefits:

- 4x20 Character Liquid Crystal Alpha-numerical Display
- User Configurable
- Run-Time Hours
- Current Unit Mode Status
- Alarm Status
- Digital & Analog Inputs / Outputs
- Temperature Anticipation
- Remote Stop / Start Contact

- Summary Alarm Contact
- Automatic or Manual (selectable) Restart After Power Loss
- Sequential Load After Restart
- Recovery Delay
- Compressor Short Cycle Timers
- Cold Start Time Delay
- Security Password Access
- Self-Diagnostics
- Service Mode

Unit Status Display

The control system shall display current unit functions and room status (if applicable):

- Current Dry Bulb Temp Set Point
- Current Relative Humidity Set Point
- System ON/OFF
- Cooling
- Heating
- Humidifying
- Dehumidifying
- Reheating
- Actual Room DB Temperature
- Actual Room Relative Humidity

Alarm Conditions:

Alarm conditions activate an audible and visual indicator plus close a summary alarm dry contact connection. The control system shall alert to the following alarm conditions (if applicable):

- | | |
|--------------------|----------------------|
| • High Temperature | • High Head Press |
| • Low Temperature | • Smoke Detection |
| • High Humidity | • Firestat |
| • Low Humidity | • Leak Detection |
| • Sensor Failure | • Loss of Power |
| • Summary Failure | • Dirty Filter |
| • Loss of Air Flow | • Loss of Fluid Flow |

Digital & Analog Control Inputs / Outputs:

The control system shall be capable of both digital (ON/OFF) and analog (proportional integral, PI) input and output control.

Select MC-2000 Options:

- Multi-Unit N+1 Sequencing
- BMS Communications Interface:
 - BACnet over MS/TP (RS485 Serial)
 - BACnet Over IP (Ethernet / EIA485)
 - ModBus RS485 Serial Connection

Floor Stand



A ___ inch nominal high (___ in to ___ in adj. range) floor stand shall be factory provided for field installation. The floor stand shall have adjustable legs with vibration isolation.

(Note: Seismic Rated Floor Stands are optionally available.)

Turning Vanes

Turning vanes shall be factory provided with the floor stand to direct the discharge air either to the front or rear of the unit.

Condensate Pump

(Factory Installed - Both UF & DF!)



A condensate pump shall be factory provided and installed within the indoor evaporator section (Up-Flow & Down-

Flow Air Pattern Configurations). The condensate pump shall be provided with dual internal float switches: one for pump operation initiation and the other for pump reservoir overflow safety.

Main Power, Non-Fused Disconnect *(Remote Condenser Section)*



The remote condenser shall be factory provided with a main power non-fused disconnect for field installation. The disconnect shall be NEMA rated for indoor or outdoor installation as required.

Remote Water-Leak Detector



A remote water-leak detector shall be factory provided for field installation. The remote water-leak detector shall be wired to shut down all A/C unit water producing functions upon sensing a water leak.

(Note: Cable Type Remote Water Detectors are also optionally available.)

Floor Stand Options

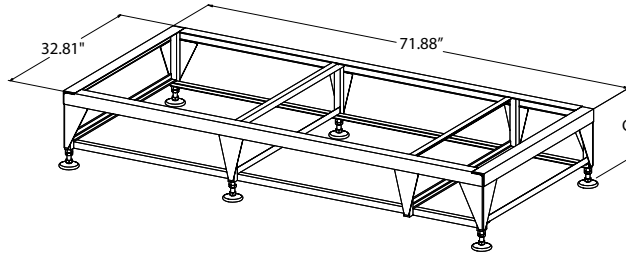

A-Cabinet ... 21-35kW (6-10 Tons)

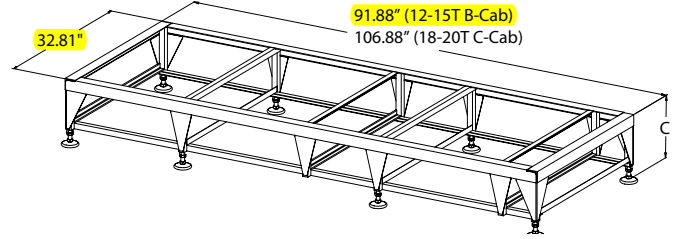

B & C-Cabinets ... 42-70kW (12-20 Tons)

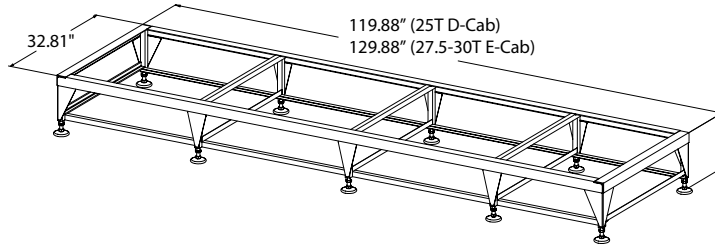

D & E-Cabinets ... 88-105kW (25-30 Tons)

Floor Stand Model (MC2-DX)	Nominal Height "C"	Nominal Weight (lbs) - (Shipping Skid Not Included)									
		A-Cabinet (21-35kW, 6-10T)		B-Cabinet (42-53kW, 12-15T)		C-Cabinet (63-70kW, 18-20T)		D-Cabinet (88kW, 25T)		E-Cabinet (97-105kW, 27.5-30T)	
		Floor Stand	Turning Vane	Floor Stand	Turning Vane	Floor Stand	Turning Vane	Floor Stand	Turning Vane	Floor Stand	Turning Vane
FS2P-04	4.0" (3.75"-4.75" Adj.)	53	N/A	67	N/A	73	N/A	79	N/A	83	N/A
FS2P-05	5.0" (4.25"-5.38" Adj.)	53	N/A	67	N/A	73	N/A	79	N/A	83	N/A
FS2P-06	6.0" (5.25"-8.25" Adj.)	53	N/A	67	N/A	74	N/A	80	N/A	84	N/A
FS2P-09	9.0" (8.25"-11.25" Adj.)	57	N/A	73	N/A	79	N/A	86	N/A	90	N/A
FS2P-12	12.0" (11.25"-14.25" Adj.)	81	18	107	29	115	30	117	40	123	40
FS2P-15	15.0" (14.25"-17.25" Adj.)	86	20	114	32	122	32	123	43	128	43
FS2P-18	18.0" (17.25"-20.25" Adj.)	90	23	120	37	128	38	128	49	134	49
FS2P-24	24.0" (23.25"-26.25" Adj.)	99	26	133	43	141	44	139	58	145	58

Outdoor, DX - Air Cooled Propeller Fan, Remote Condensers

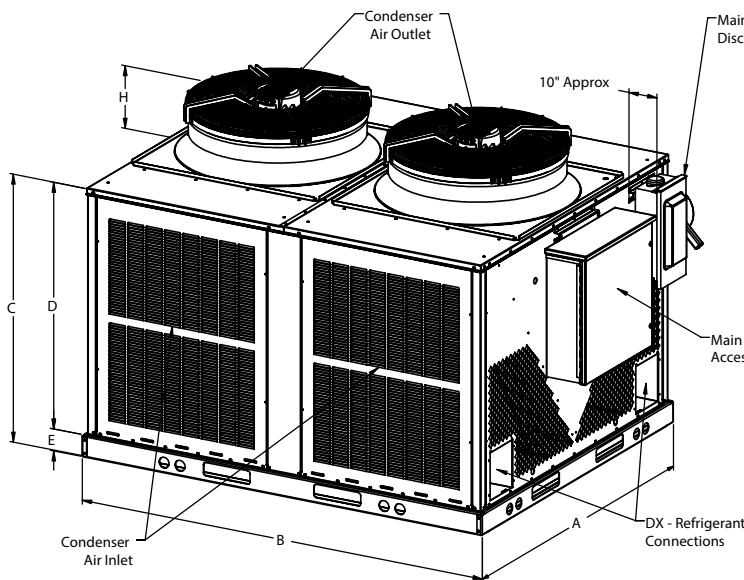

Front / Top / Right

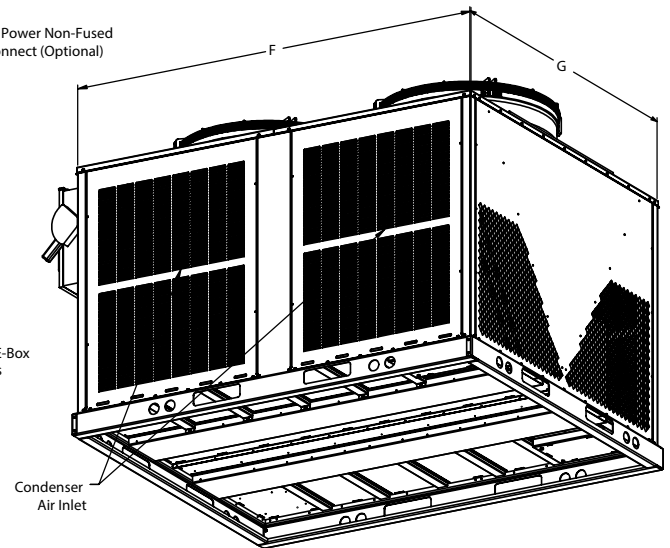

Rear / Left / Bottom

Unit Size	Model	A	B	C	D	E	F	G	H
6-35kW (6-10T)	XPX-021D/035D-*	63.69"	72.70"	48.38"	44.25"	4.13"	71.25"	62.00"	9.33"
42-70kW (12-20T)	XPX-042D/070D-*	67.69"	81.45"	50.38"	46.25"	4.13"	80.00"	66.00"	11.81"
88-105kW (25-30T)	XPX-088D/105D-*	67.69"	86.45"	50.38"	46.25"	4.13"	85.00"	66.00"	11.81"

Typical Wiring Schematic - MC2-DX (21-105kW, 6-30 Tons)

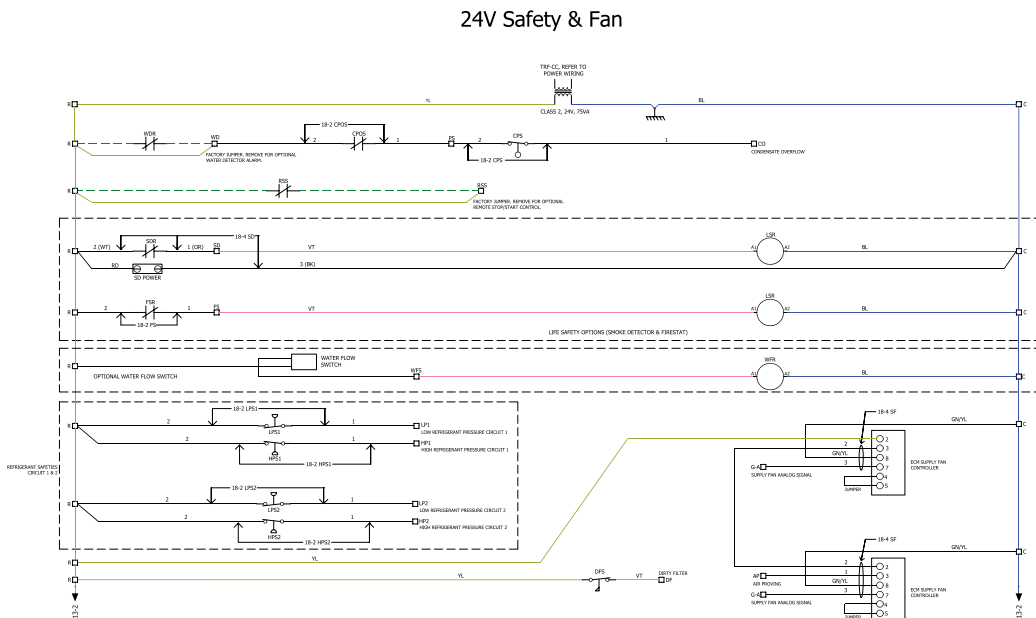
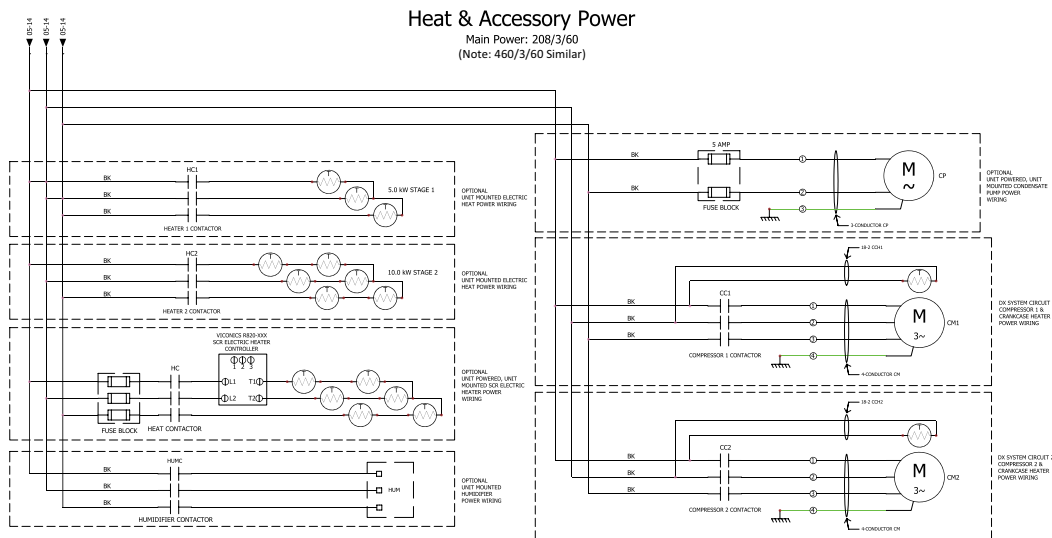
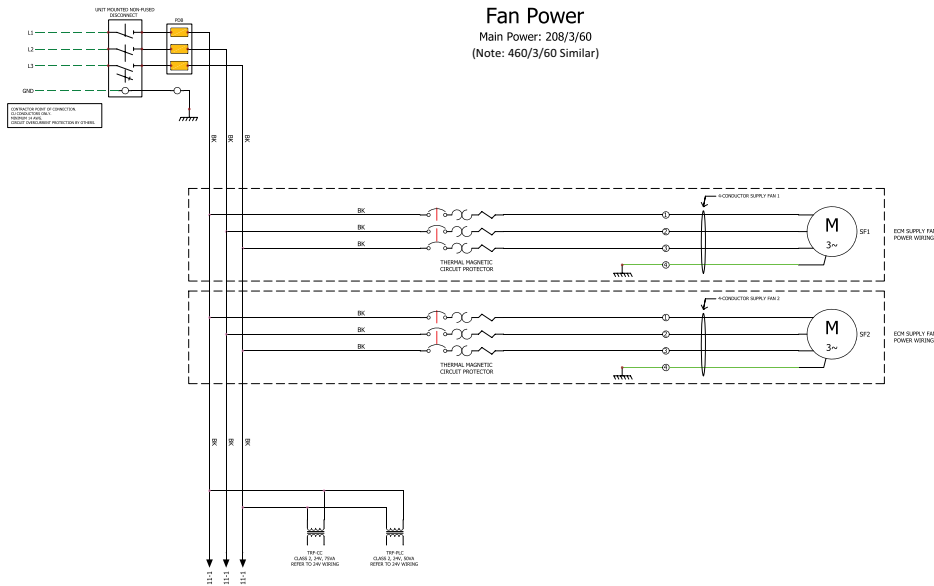

Typical Wiring Schematic - MC2-DX (21-105kW, 6-30 Tons)

24V Cooling

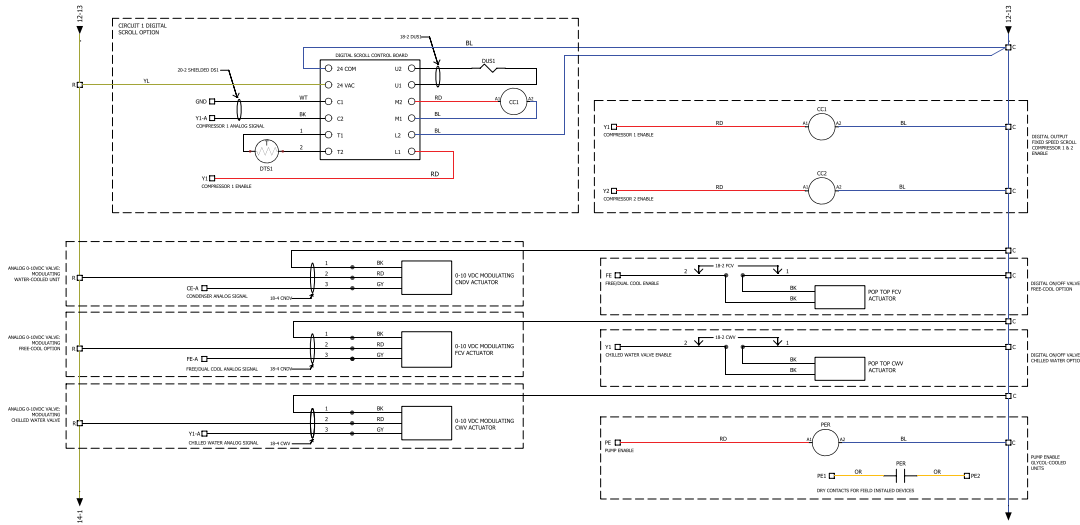

24V Heat & Humidification

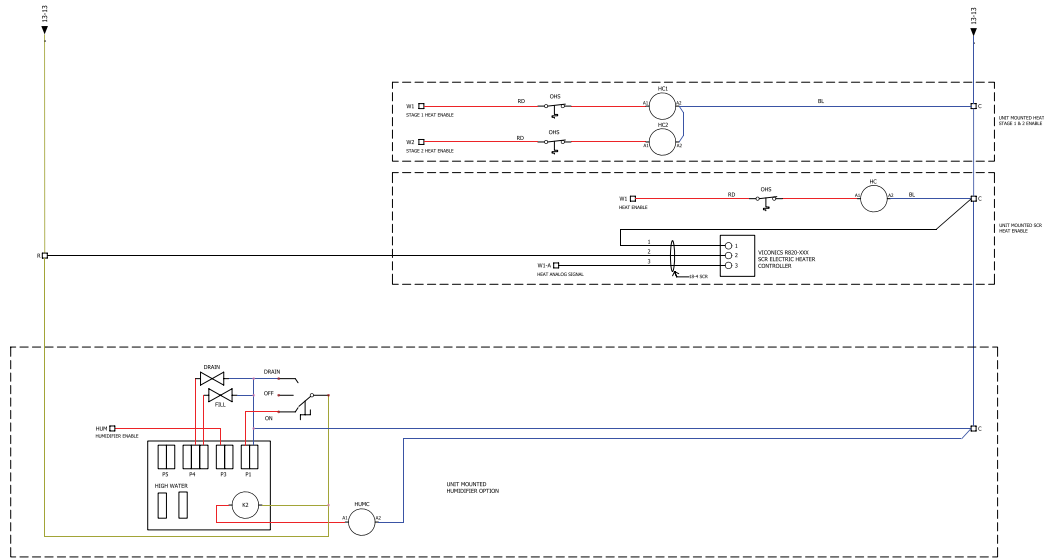

Sample Control Wiring

Control Sequence: MC-2000S UH

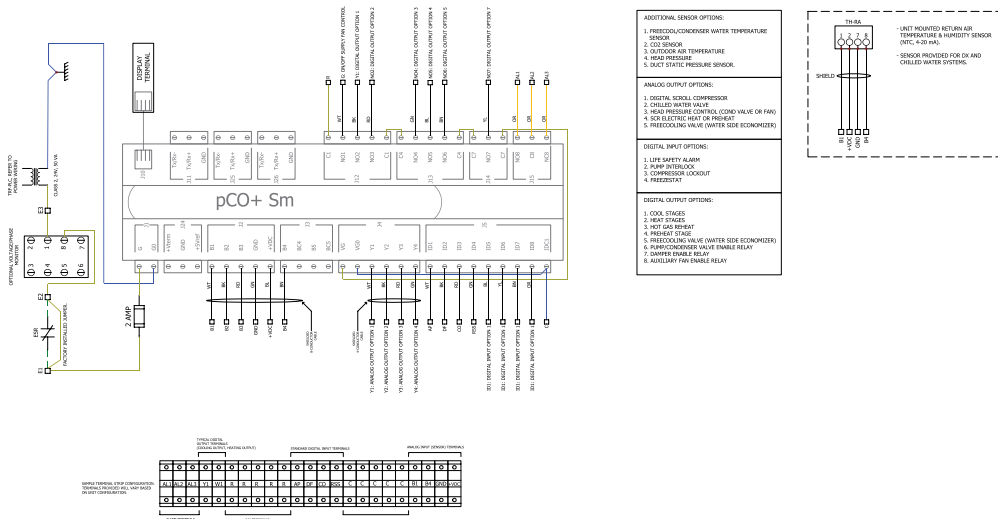

MC-2000S RT Temperature Only Control

The MC-2000S RT control sequence provides temperature control of a single zone. The outdoor air percentage should be no greater than 20%. This control sequence indicates all options; refer to your submittal and wiring diagram to verify which options apply to your unit.

Unit Operation

Unit operation is initiated when all points are in their run positions.

System Enable: The system enable is controlled at the unit's display terminal, within the system enable menu.

Remote Stop/Start: Remote stop/start NC contacts are provided on all units and ship from the factory jumpered for continuous operation.

BMS Control: The unit is provided with an optional point that may be written by a BMS to index unit operation.

Schedule Control: The unit is provided with a local schedule that may be set to operate the unit in Occupied or Unoccupied modes based on its time clock.

Fan Control

When the unit is indexed for operation and in its occupied mode, the supply fan shall be energized after a 30 second delay (adj.) to allow for optional control damper actuation. The fan shall run continuously. After an additional 15 second delay (adj.) to allow for air proving, the unit shall operate as described herein.

Set Point Control (Optional): The system is provided with direct-drive, backwards inclined ECM impellers for balancing only. Fan will maintain a constant speed setting (100% output, adj.).

System Mode

The unit provides automatic change-over between cooling and heating operation. The cooling and heating set points are separated by a dead band (5°F, adj.) to minimize unit cycling and prevent simultaneous cooling and heating.

Cooling Operation

On a rise in space temperature by 1°F above the cooling set point (75°F, adj.), the unit shall energize its first compressor stage. *The first compressor shall energize at 100% and modulate to meet the space set point (digital scrolls only).* For dual circuit units, on a rise in space temperature by an ad-

ditional 1°F, and a minimum delay of 3 minutes, the second compressor stage shall energize.

On a fall in space temperature, the second compressor stage (if applicable) shall de-energize. On a continued fall in space temperature, the first compressor stage shall be de-energized.

All compressors are subject to a minimum run time of 3 minutes and a minimum off time of 3 minutes to prevent short cycling.

Economizer (Air-Side Economizer, Optional)

If the outside air condition is below the economizer set point (69°F, adj.), the unit shall modulate the economizer dampers open. If the outdoor air temperature falls below 55°F (adj.), mechanical cooling shall be locked out and the dampers shall modulate to maintain 55°F into the unit.

On a fall in space temperature, the dampers shall return to their normal positions.

CO2 Damper Control (Optional): The economizer damper may also be set to respond to space CO2 level to provide demand control ventilation (<20% outdoor air). If the space CO2 level rises above the CO2 set point (700 ppm, adj.) by 50 ppm, the damper shall open to provide the unit's maximum outdoor air supply (<20%). On a fall in space CO2 level, the damper shall return to its minimum position. If both economizer and CO2 operation are required simultaneously, the damper shall open to satisfy the larger requirement.

Freecool (Water-Side Economizer, Water Cooled Only, Optional)

If the condenser water temperature is below the freecool set point (45°F, adj.), the unit shall energize its freecooling valve as its first stage of cooling in lieu of the first compressor stage. *The valve shall modulate to meet the space set point (modulating valves only).*

On a fall in space temperature, the freecool valve shall be de-energized.

On a continued rise in space temperature by 1°F and a minimum delay of 3 minutes, the freecool valve shall be de-energized and the unit shall sequence its mechanical cooling stages to meet the temperature requirement.

Heating Operation

On a fall in space temperature by 1°F below the heating set point (70°F, adj.), the unit shall energize its first heating stage. *The first heating stage shall modulate to meet the space set point (SCR or modulating valves only).* On a fall in space temperature by an additional 1°F, and a minimum delay of 3 minutes, the second heat stage shall energize.

On a rise in space temperature, the second heat stage (if applicable) shall de-energize. On a continued rise in space temperature, the first heat stage shall be de-energized.

Head Pressure Control (Fan Cycling)

Condenser fan operation shall be controlled by a fan cycling switch. On a rise in system pressure above 275 psig, the condenser fan shall be energized. On a fall in system pressure below 210 psig, the condenser fan shall be de-energized.

Note: not available with digital scroll compressor option.

Head Pressure Control (Air-Cooled Units, ECM or VFD)

The condenser fan motor shall ramp up gently and operate continuously while the compressors are operating. The fan shall vary its speed to maintain the head pressure set point (325 psig, adj.), as controlled by the adjustable head pressure control PID loop.

Head Pressure Control (Air-Cooled Units, p266)

The condenser fan motor shall ramp up gently and operate continuously while the compressors are operating. The p266 controller shall vary the fan speed to maintain the head pressure set point.

Head Pressure Control (Flooded Head Pressure)

The unit is provided with a flooded head pressure control valve. On a rise in condensing pressure above 275 psig, the head pressure control valve opens to allow liquid refrigerant to flow from the condenser into the receiver. On a fall in condensing pressure, the valve modulates to bypass discharge gas around the condenser; this bypass causes the pressure at the outlet of the condenser to increase and the condenser floods with liquid refrigerant.

Note: not available with digital scroll compressor option.

Head Pressure Control (Water-Cooled Units, modulating valve)

On a call for compressor operation, the compressor start shall be delayed for 60 seconds (adj.) to allow the valve to

fully open. After an initial modulation delay of 90 seconds (adj.), the valve shall modulate between its minimum and maximum operating positions based on the adjustable head pressure control PID loop and head pressure set point (325 psig, adj.).

Head Pressure Control (Water-Cooled Units, mechanical valve)

The unit is provided with a direct-acting pressure-actuated water control valve. On an increase in condenser pressure, the water control valve shall modulate towards its open position. On a decrease in condenser pressure, the valve shall modulate towards its closed position.

Note: not available with digital scroll compressor option.

Unoccupied Operation

If the unit utilizes the system schedule, then during unoccupied hours the fan shall be de-energized. If the space temperature falls below the unoccupied heat set point (60°F, adj.) by 1°F or rises above the unoccupied cooling set point (80°F, adj.) by 1°F, the fan shall energize and the unit shall operate as described herein. On satisfaction of unoccupied set point, the unit shall de-energize the fan.

System Alarms

Air Proving: A differential pressure switch or current sensing switch (optional) closes to confirm airflow prior to the activation of other mechanical components. If the switch doesn't close after an adjustable time delay or opens during unit operation, the unit shall lock-out operation and enunciate an alarm.

Dirty Filter: An adjustable differential pressure switch shall open when the pressure drop across the filter exceeds the desired pressure drop and enunciates an alarm.

Condensate Alarm: A condensate pan switch, condensate pump overflow switch (optional), and water leak detector (optional) are connected in a NC series to detect high condensate. On a high condensate condition, the circuit will open and shut down all mechanical cooling or lock-out unit operation (optional) and enunciate an alarm.

High Refrigerant Pressure: The high refrigerant pressure (>600 psig, auto-reset) switch shall open on a high pressure condition and shut down compressor operation. If the switch resets, the system will attempt to restart the compressor up to 3 times in 10 minutes. If the switch does not reset within 90 seconds or on 3 failed start attempts, the system

shall lock-out compressor operation, and enunciate an alarm.

Low Refrigerant Pressure: The low refrigerant pressure (<50 psig) shall open on a low pressure condition and after a time delay (90s, adjustable), shall lock-out compressor operation and enunciate an alarm.

Life Safety: A smoke detector (optional) and firestat (optional) or remote life safety system shall open a relay and break control power to the microprocessor. Unit operation shall cease. The Life Safety Alarm may optionally be routed through the controller to enunciate an alarm and signal the BMS.

Sensor Failure: If a sensor is reading out of range for 5 minutes, the unit shall enunciate an alarm to indicate an issue with the sensor.

High and Low Limit Alarms: Adjustable high and low limit alarms are user-adjustable for sensor points.

Waterflow Switch (Optional): A differential water pressure switch is factory installed on the water lines; if the differential pressure falls below the adjustable set point, compressor operation shall be locked out.