

SUBMITTAL DATA

Order #: **Date:** 07/16/2024
Project: Riverbank Community Center
Project #:

RTU-1 PAGE 3
RTU-2 PAGE 10

Date

07/16/2024

Project Name

Riverbank Community Center

Project Number

Client / Purchaser



Submittal Summary Page

| Qty | Tag # | Model # / Material # | Description |
|-----|----------|----------------------|--|
| 1 | RTU-1 | XYE04A1B1AA1A121A3 | 3 Ton, York Sun Core Single Packaged R-410A High Efficiency Heat Pump, 15.0 SEER / 12.5 EER, 208/230-1-60 <ul style="list-style-type: none"> • Medium Static Belt Drive Blower • Smart Equipment Controller including Discharge Air, Return Air, and Outdoor Air Temperature Sensors. • Non-fused Disconnect (60 Amp) • Copper tube/Aluminum fin Condenser Coil, Copper tube/Aluminum fin Evaporator Coil |
| 1 | RTU-1 | 2EK04510625 | 6.5 kW 208/230-3(1)-60 Electric Heat |
| 1 | RTU-1 | 1HG0419 | Hail Guard Kit (Small Footprint Short Cabinet) |
| 1 | RTU-1 | 1TB0403 | Small Footprint Thru The Base Electrical & Gas |
| 1 | RTU-2 | XYE05A1B1AA1A121A3 | 4 Ton, York Sun Core Single Packaged R-410A High Efficiency Heat Pump, 15.0 SEER / 12.5 EER, 208/230-1-60 <ul style="list-style-type: none"> • Medium Static Belt Drive Blower • Smart Equipment Controller including Discharge Air, Return Air, and Outdoor Air Temperature Sensors. • Non-fused Disconnect (60 Amp) • Copper tube/Aluminum fin Condenser Coil, Copper tube/Aluminum fin Evaporator Coil |
| 1 | RTU-2 | 2EK04510625 | 6.5 kW 208/230-3(1)-60 Electric Heat |
| 1 | RTU-2 | 1HG0420 | Hail Guard Kit (Small Footprint Tall Cabinet) |
| 1 | RTU-2 | 1TB0403 | Small Footprint Thru The Base Electrical & Gas |
| 2 | RTU-1, 2 | PEDCPRSDB06M | Modulating power exhaust/econo 230v 1ph |
| 2 | RTU-1, 2 | T4950SCH-IAQ | Commercial Explorer IAQ School Thermostat, Weekday/ Weekend Programmable, 4 HT/2 CL, Push to Start w/ Wi-Fi, Humidification-Dehumidification Controls, & 3-Security Levels |
| 2 | RTU-1, 2 | KDKITPRS | Small Sun Core Calculated Hold-Down Clip Kit for 8" to 14" Knock Down Roof Curbs. Conforms to CBC and IBC |
| 2 | RTU-1, 2 | CBKDPRS14 | Small Sun Core 14" Tall Knock Down Roof Curb |
| 2 | | ACC0625 | Lock Ring for Explorer Stats |
| 2 | | S1-C7233A1008 | CO2 DETECTOR WALL MOUNT |

Equipment start-up and commissioning by a factory trained technician is recommended.
 Contact your supplying distributor or sales representative for additional information & guidance.



WARNING: Cancer and Reproductive Harm - www.P65Warnings.ca.gov

Single Package R-410A Heat Pump

Project Name: **Riverbank Community Center**

Unit Model #: **XYE04A1B1AA1A121A3**

Quantity: 1 Tag #: **RTU-1**

System: **XYE04A1B1AA1A121A3**

Cooling Performance

| | |
|------------------------------|-------------|
| Total gross capacity | 39.0 MBH |
| Sensible gross capacity | 27.7 MBH |
| Total net capacity | 37.1 MBH |
| Sensible net capacity | 25.8 MBH |
| Seasonal Efficiency (at ARI) | 15.00 SEER |
| Seasonal Efficiency (at ARI) | 14.20 SEER2 |
| Efficiency (at ARI) | 12.50 EER |
| Efficiency (at ARI) | 12.00 EER2 |
| Ambient DB temp. | 95.0 °F |
| Entering DB temp. | 80.0 °F |
| Entering WB temp. | 67.0 °F |
| Evap Coil Leaving DB temp. | 58.6 °F |
| Evap Coil Leaving WB temp. | 56.7 °F |
| Unit Leaving DB temp. | 60.1 °F |
| Unit Leaving WB temp. | 57.3 °F |
| Leaving air temp dew point | 55.50 °F |
| Power input (w/o blower) | 2.60 kW |
| Sound power | 79 dB(a) |

Refrigerant

| | |
|------------------|--------|
| Refrigerant type | R-410A |
| Sys1 | 12 lb |

Heat Pump Performance

| | |
|-----------------------|-----------|
| Ambient DB temp. | 47 °F |
| Entering DB temp. | 60 °F |
| Leaving DB temp. | 86.8 °F |
| Air temp. rise | 26.8 °F |
| Design Gross Capacity | 34.7 MBH |
| Design Power Input | 2.8 kW |
| HSPF | 8 |
| HSPF2 | 7.1 |
| Capacity @ 47(°F) | 34.00 MBH |
| COP @ 47(°F) | 3.30 COP |
| Capacity @ 17(°F) | 20.40 MBH |
| COP @ 17(°F) | 2.00 COP |
| Applied electric heat | 4.9 kW |

Heating Performance

| | |
|-------------------------------|----------|
| Entering DB temp. | 60 °F |
| Heating output capacity (Max) | 16.7 MBH |
| Nominal electric heat | 6.5 kW |
| Applied electric heat | 4.9 kW |
| Installed | Field |
| Supply air | 1200 cfm |
| Leaving DB temp. | 72.9 °F |
| Air temp. rise | 12.9 °F |
| Stages | 1 |

Supply Air Blower Performance

| | |
|---|----------|
| Supply air | 1200 cfm |
| Ext. static pressure | 0.65 IWG |
| Addl. Unit Losses (Options/Accessories) | 0.01 IWG |
| Blower speed | 1033 rpm |
| Max BHP of Motor (including service factor) | 2.40 HP |
| Duct location | Bottom |
| Motor rating | 1.50 HP |
| Actual required BHP | 0.61 HP |
| Power input | 0.57 kW |
| Elevation | 0 ft |
| Drive type | BELT |

Outside/Mixed Air

| | |
|-----------------|---------|
| Outside Air cfm | 455 cfm |
|-----------------|---------|

Electrical Data

| | | |
|----------------------------------|----------|----------|
| Power supply | 208-1-60 | 230-1-60 |
| Unit min circuit ampacity | 58.4 A | 62.5 A |
| Unit min over-current protection | 60 A | 70 A |
| Unit max over-current protection | 60 A | 70 A |

Dimensions & Weight

| | | |
|---------------------------------------|-----------|-----------|
| Hgt 33 in | Len 74 in | Wth 49 in |
| Weight with factory installed options | | 545 lb |

Clearances

| | | | | | |
|-------|-------|-------|-------|------|-------|
| Right | 18 in | Front | 36 in | Rear | 18 in |
|-------|-------|-------|-------|------|-------|



3 Ton

- All units are manufactured at an ISO 9001 registered facility and each rooftop is completely computer-run tested prior to shipment.

Unit Features

- Unit Cabinet Constructed of Powder Painted Steel, Certified At 750 Hours Salt Spray Test (ASTM B-117 Standards)
- Either supply and/or return can be field converted from vertical to horizontal configuration without cutting panels.
- Full perimeter base rails with built in rigging capabilities
- Scroll Compressors
- Medium Static Belt Drive Blower
- Solid Core Liquid Line Filter Driers
- Unit Ships with 2" Throwaway Filters
- Replacement Filters: 2 - (16" x 25"). Unit accepts 2" or 4" wide filters.**
- Single Point Power Connection
- Short Circuit Current: 5kA RMS Symmetrical
- Non-fused Disconnect (60 Amp)
- Copper tube/Aluminum fin Condenser Coil, Copper tube/Aluminum fin Evaporator Coil

Standard Unit Controller

- Safety Monitoring - Monitors the high and low-pressure switches, the freezestats, the gas valve, if applicable, and the temperature limit switch on gas and electric heat units. The unit control board will alarm on ignition failures, safety lockouts and repeated limit switch trips.
- An Integrated Low-Ambient Control, Anti-Short Cycle Protection, Lead-Lag, Fan On and Fan off Delays, Low Voltage Protection, Allows all units to operate in the cooling mode down to 0 °F outdoor ambient without additional components or intervention.
- Smart Equipment Control Board
- On-Board Diagnostic and Fault Code display

BAS Controller

- Smart Equipment Controller including Discharge Air, Return Air, and Outdoor Air Temperature Sensors.

Warranty

- One (1) Year Limited Warranty on the Complete Unit
- Five (5) Year Warranty - Compressors



York® Sun™ Core 3-12.5 Ton Package

Single Package R-410A Heat Pump

Project Name: **Riverbank Community Center**

Unit Model #: **XYE04A1B1AA1A121A3**

Quantity: **1** Tag #: **RTU-1**

System: **XYE04A1B1AA1A121A3**

Top 72 in Bottom 1 in Left 12 in

Note: Please refer to the tech guide for listed maximum static pressures





York® Sun™ Core 3-12.5 Ton Package

Single Package R-410A Heat Pump

Project Name: Riverbank Community Center

Unit Model #: XYE04A1B1AA1A121A3

Quantity: 1 Tag #: RTU-1

System: XYE04A1B1AA1A121A3

Additional Electrical Data

| | |
|---------------------------------------|----------|
| Power supply | 208-1-60 |
| Unit min circuit ampacity | 58.4 A |
| Unit max over-current protection | 60 A |
| Min Voltage | 187 V |
| Max Voltage | 252 V |
| Comp #1 RLA | 15.4 |
| Comp #1 LRA | 83.9 |
| Indoor Mtr Voltage | 208-1-60 |
| Indoor Mtr FLA | 7.6 |
| Outdoor Mtr Qty | 1 |
| Outdoor Fan Voltage | 208-1-60 |
| OD Fan Mtr FLA (ea.) | 2.0 |
| Power Ex Mtr Qty (if applicable) | 1 |
| Powered Ex Voltage(if applicable) | 208-1-60 |
| Power Ex Mtr FLA (ea) (if applicable) | 1.5 |



York® Sun™ Core 3-12.5 Ton Package

Single Package R-410A Heat Pump

Project Name: Riverbank Community Center

Unit Model #: XYE04A1B1AA1A121A3

Quantity: 1 Tag #: RTU-1

System: XYE04A1B1AA1A121A3

Factory Installed Options

XYE04A1B1AA1A121A3

| Equipment Options | Option(s) Selected |
|---------------------------|---|
| Product Category: | XY York Sun Core Single Packaged R-410A High Efficiency Heat Pump |
| Heat Type: | E |
| Nominal Cooling Capacity: | 04 3 Ton 15.0 SEER / 12.5 EER |
| Heat Size: | A |
| Voltage: | 1 208/230-1-60 |
| Airflow: | B Medium Static Belt Drive Blower |
| Airflow Options: | 1 |
| Coil Options: | A Copper tube/Aluminum fin Condenser Coil, Copper tube/Aluminum fin Evaporator Coil |
| Controls: | A Smart Equipment Controller including Discharge Air, Return Air, and Outdoor Air Temperature Sensors. |
| Sensor Options: | 1 |
| Economizer / Damper: | A |
| Convenience Outlet: | 1 |
| Electrical Options: | 2 Non-fused Disconnect (60 Amp) |
| Cabinet Options: | 1 |
| Special Options: | A |
| Product Generation: | 3 |

Field Installed Accessories

- 1BD0409 - Burglar Bars (Small Footprint) (32.0 lbs)
- 1FA0415 - Manual O.A. Damper with Hood Kit- 0% to 25% Capability Small Footprint 2-position (25.0 lbs)
- 1FA0419 - Manual Fresh Air Damper installed on side-flow RA cover, 0-35%, Small Footprint (25.0 lbs)
- 1HG0419 - Hail Guard Kit (Small Footprint Short Cabinet) (19.0 lbs)
- 1RC0456 - Curb Rigid 14" (356 mm) Small Footprint (145.0 lbs)
- 1RC0458 - Curb Rigid 24" (610 mm) Small Footprint (135.0 lbs)
- 1TB0401 - Small Footprint Thru The Base Electrical & Thru The Curb Gas (1.0 lbs)
- 1TB0403 - Small Footprint Thru The Base Electrical & Gas (1.0 lbs)
- 2EC0401 - Kit, Single Enthalpy Field Installed (1.0 lbs)
- 2EE04706724 - Economizer, DB, Vertical Flow, Small Footprint (with Barometric Relief) (63.0 lbs)
- 2EK04510625 - 6.5 kW 208/230-3(1)-60 Electric Heat (9.6 lbs)
- 2EK04511125 - 10.5 kW 208/230-3(1)-60 Electric Heat (14.6 lbs)
- 2MD04704224 - Motorized O.A. Damper with Hood Kit- 0% to 100% Capability Small Footprint 0-100% 2-position (36.0 lbs)
- 2MD04704424 - Motorized Fresh Air Damper, 0-35% installed on side flow RA cover, Small Footprint (36.0 lbs)
- 2PM04700224 - Phase Monitor Kit (1.0 lbs)
- 2SD04701124 - Smoke Detector - Return (Downflow Only) (12.0 lbs)
- 2SD04701224 - Smoke Detector - Supply (12.0 lbs)
- 2SD04701324 - Smoke Detector - Supply (Horizontal/Downflow) and Return (Downflow Only) (12.0 lbs)



York® Sun™ Core 3-12.5 Ton Package

Single Package R-410A Heat Pump

Project Name: **Riverbank Community Center**Unit Model #: **XYE04A1B1AA1A121A3**Quantity: **1** Tag #: **RTU-1**System: **XYE04A1B1AA1A121A3**

- S1-03102529000 - Non-Networking Wall Sensor – Allows remote sensing and control from single or multiple zones. (0.2 lbs)
- S1-03102529004 - Non-Networking Wall Sensor with Over-ride button – Allows remote sensing and control from single or multiple zones. Override allows setpoint to be overridden for 2 hour time period. (0.2 lbs)
- S1-ADDWIRE - Add-a-Wire allows 5-wire thermostats to use only 4 wires. (0.3 lbs)
- S1-CTS DTS - CTS Wired Temperature Sensor for thermostat | Duct *Also works for LX Series (0.3 lbs)
- S1-CTS HTS - CTS Hardwired Temperature Sensor for CTS Thermostats *Works with LX series as well (0.2 lbs)
- S1-CTS PLATE - Wall Plate for CTS Thermostats *Also works for new platform LX series models below (0.0 lbs)
- S1-CTS WFTS - CTS Temperature Sensor with WiFi for CTS Thermostats *Also works with LX Series (0.1 lbs)
- S1-LX LOCK - Locking Ring For LX-Series Thermostats (0.4 lbs)
- S1-LX PLATE - Wall Plate For LX-Series Thermostats (0.0 lbs)
- S1-LX WFM - For LX Series Thermostats - WiFi Communication (0.1 lbs)
- S1-MP-PRTKIT-0P - MAP (Multiple Access Portal) Gateway Kit- Replacement MAP gateway protective case, lanyard and communication cable. Use only to replace worn or damaged components. (0.3 lbs)
- S1-MP-STAFBA-0 - Field Bus Adapter (Includes RJ-12 to 4-position Terminal Block Adapter. Used for interfacing directly to MS/TP Field Bus) (1.0 lbs)
- S1-MP-STAKIT-0 - Stationary Cradle Only (Includes mounting bracket and field bus adapter) (0.1 lbs)
- S1-MP-STAKIT-0H - Stationary Cradle Kit (Includes mounting bracket, field bus adapter, and 100-240 VAC line voltage power supply) (1.0 lbs)
- S1-NSB8BHN041-0 - Wall Temperature and 3% Relative Humidity Combined Sensor, No Display, WHITE, NO JCI LOGO, NS8000 Series (0.4 lbs)
- S1-NSB8BHN043-0 - Wall Temperature and 3% Relative Humidity Combined Sensor, No Display, BLACK, NO JCI LOGO, NS8000 Series (0.4 lbs)
- S1-NSB8BHN141-0 - Wall Temperature and 3% Relative Humidity Combined Sensor, Warmer/Cooler Display, WHITE, NO JCI LOGO, NS8000 Series (0.4 lbs)
- S1-NSB8BHN143-0 - Wall Temperature and 3% Relative Humidity Combined Sensor, Warmer/Cooler Display, BLACK, NO JCI LOGO, NS8000 Series (0.4 lbs)
- S1-NSB8BHN240-0 - Zone Temperature Sensor. +3% RH, LCD DISPLAY, LOCAL SETPOINT CONTROL , WHITE, WITH JCI LOGO (0.4 lbs)
- S1-NSB8BHN241-0 - Zone Temperature Sensor. +3% RH, LCD DISPLAY, LOCAL SETPOINT CONTROL , WHITE, NO LOGO (0.4 lbs)
- S1-NSB8BHN243-0 - Wall Temperature and 3% Relative Humidity Combined Sensor, Full Display, BLACK, NO JCI LOGO, NS8000 Series (0.4 lbs)
- S1-NSB8BPN240-0 - Wall Temperature and 2% Relative Humidity Combined Sensor, Full Display, WHITE, JCI LOGO, NS8000 Series (0.4 lbs)
- S1-NSB8BPN241-0 - Wall Temperature and 2% Relative Humidity Combined Sensor, Full Display, WHITE, NO JCI LOGO, NS8000 Series (0.4 lbs)
- S1-NSB8BPN243-0 - Wall Temperature and 2% Relative Humidity Combined Sensor, Full Display, BLACK, NO JCI LOGO, NS8000 Series (0.4 lbs)
- S1-NSB8BTN041-0 - Zone Temperature Sensor Only, NO DISPLAY, NO SETPOINT CONTROL , WHITE, NO LOGO (0.4 lbs)
- S1-NSB8BTN141-0 - Zone Temperature Sensor Only, NO DISPLAY, WARMER/COOLER TEMP. ADJUSTMENT , WHITE, NO LOGO (0.4 lbs)
- S1-NSB8BTN143-0 - Wall Temperature Sensor, Warmer/Cooler Display, BLACK, NO JCI LOGO, NS8000 Series (0.4 lbs)
- S1-NSB8BTN240-0 - Zone Temperature Sensor Only, LCD DISPLAY, LOCAL SETPOINT CONTROL , WHITE, WITH JCI LOGO (0.4 lbs)
- S1-NSB8BTN241-0 - Zone Temperature Sensor Only, LCD DISPLAY, LOCAL SETPOINT CONTROL , WHITE, NO LOGO (0.4 lbs)
- S1-NSB8BTN243-0 - Wall Temperature Sensor, Full Display, BLACK, NO JCI LOGO, NS8000 Series (0.4 lbs)
- S1-SE-COM1001-0 - Field Installed Communication Card for Simplicity SE control. Can be field configurable for BACnet, N2 or ModBUS MSTP (0.0 lbs)
- S1-TBSU305-Y - York Branded LX Series | 3" LCD Display | 3/4 Stage Heating | 2 Stage Cooling | (5+1+1) 7-day Programmable (1.0 lbs)
- S1-TEC3630-14-000 - 7 DAY PROGRAMMABLE THERMOSTAT, OPTIONAL MSTP OR N2 COMMUNICATION, RTU/HEAT PUMP WITH ECON, FULL COLOR, WHITE, NO LOGO (0.8 lbs)
- S1-TL-CWCVT-0 - CWCVT (Connected Workflow Converter) (1.0 lbs)
- S1-YK/AN-RSO-ACI - Non-Networking Wall Sensor with Setpoint Adjustment and Over-ride Button – Allows remote sensing and control from single or multiple zones. (1.0 lbs)
- S1-YK-MAP1810-0P - MAP (Multiple Access Portal) Gateway- For use with SimplicitySE Control. (0.2 lbs)



York® Sun™ Core 3-12.5 Ton Package

Single Package R-410A Heat Pump

Project Name: **Riverbank Community Center**

Unit Model #: **XYE04A1B1AA1A121A3**

Quantity: **1** Tag #: **RTU-1**

System: **XYE04A1B1AA1A121A3**

- S1-YK-MAP1810-0S - Stationary MAP Gateway (Includes MAP Gateway, Field Bus Adapter, Mounting Bracket and 100 to 240 VAC Power Supply). US-compatible counties. (1.9 lbs)
- YCCP050PK012LO - One Year Labor Only AC/HP PKG 1 to 5T
- YCCP050PK012PL - One Year Renewable Parts & Labor AC/HP PKG 1 to 5T
- YCCP050PK060PL - 5 Year Parts and Labor AC/HP PKG 1 to 5T
- YCCP050PK060PO - 5 Year Parts Only (No Compressor Coverage) AC/HP PKG 1 to 5T

Project Name: **Riverbank Community Center**

 Unit Model #: **XYE04A1B1AA1A121A3**

 Quantity: **1** Tag #: **RTU-1**
Consolidated Drawing

| TONNAGE | UNIT | OPERATING WEIGHT (LBS) (BASE UNIT) | CENTER OF GRAVITY LOCATION (BASE UNIT) | | 4 POINT CORNER LOADS (LBS) (BASE UNIT) | | | |
|---------|------|------------------------------------|--|--------------|--|------------|------------|------------|
| | | | X | Y | A | B | C | D |
| 3 | XYE | 535 [242.6] | 36.5 [927.1] | 25.1 [637.5] | 138 [62.5] | 135 [61.2] | 130 [58.9] | 133 [60.3] |

- NOTES:
- FOR OUTDOOR USE ONLY.
 - WEIGHTS SHOWN ARE FOR HEAT PUMP UNITS.
 - RECOMMENDED MIN. CLEARANCES:
 RIGHT SIDE: 18 [450] W/SIDE CONDENSATE DRAIN: 24 [600]
 LEFT SIDE: 12 [300] W/PIGTAIL: 18 [450]
 FRONT: 36 [900]
 REAR: 18 [450] W/ECONOMIZER/POWER EXHAUST: 36 [900]
 TOP: 72 [1800]
 BOTTOM: 1 [25]
 - FOR SMALLER SERVICE AND OPERATIONAL CLEARANCES CONTACT YOUR APPLICATION ENGINEERING DEPARTMENT.
 - DOWNFLOW DUCTS DESIGNED TO BE ATTACHED TO ACCESSORY ROOF CURB ONLY. IF UNIT IS MOUNTED SIDE SUPPLY, IT IS RECOMMENDED THAT THE DUCTS ARE SUPPORTED BY CROSS BRACES, AS DONE ON ACCESSORY ROOF CURBS.
 - MINIMUM CONDENSATION TRAP HEIGHT SHALL BE 1.5 TIMES THE LOWEST NEGATIVE STATIC.
 - DIMENSIONS IN [] ARE IN MILLIMETERS OR KILOGRAMS.
 - OPTIONAL COIL GUARDS, DISCONNECT SWITCH SHOWN.
 - TOP PANEL EMBOSSEMENTS NOT SHOWN FOR DIMENSION CLARITY.

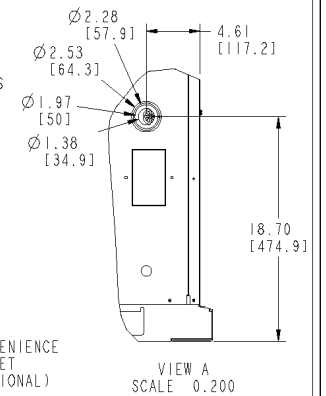
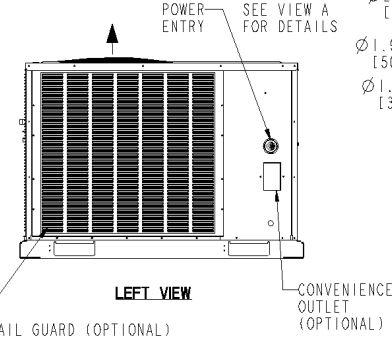
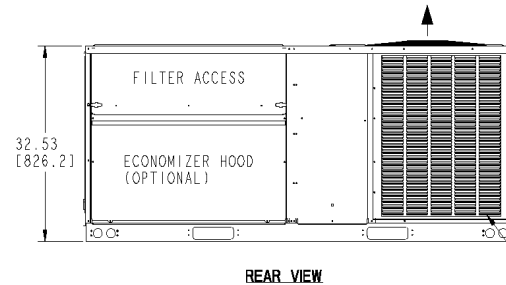
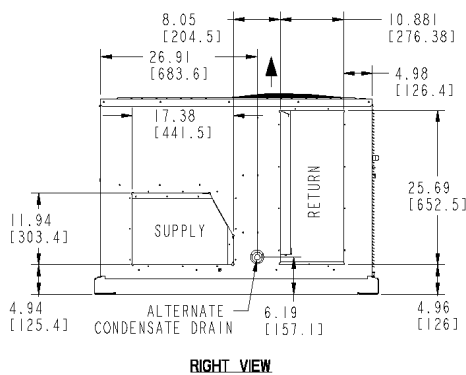
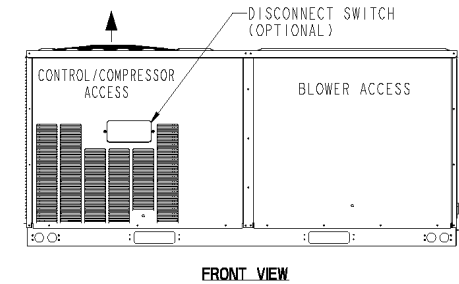
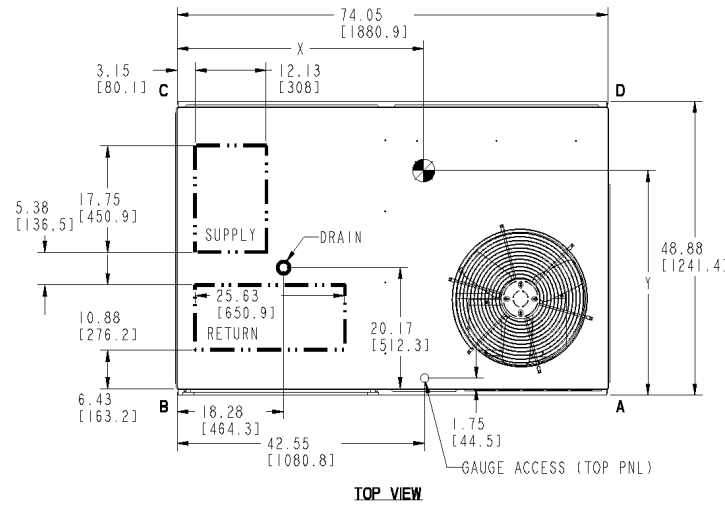

| REV | DATE | REVISION RECORD | EC NO | DR | CK | ENG | THIRD ANGLE PROJECTION | ALL PROPRIETARY RIGHTS IN THE SUBJECT MATTER HEREOF ARE RESERVED AND NO PERMISSION IS GRANTED TO REPRODUCE THIS PRINT IN WHOLE OR IN PART OR DISCLOSE ANY OF THE INFORMATION UPON IT TO OTHERS WITHOUT WRITTEN RELEASE BY JOHNSON CONTROLS DRAWING PER ASME Y14.5M-1994 TOLERANCES UNLESS OTHERWISE SPECIFIED: ONE PLACE DECIMAL = ± .1 TWO PLACE DECIMAL = ± .03 THREE PLACE DECIMAL = ± .010 ANGLES = ± 2° DIMENSIONS ARE IN INCHES DO NOT SCALE PRINT | SAFETY AND KEY CHARACTERISTICS PER BE-POP-STD-01 MATERIAL TYPE NOT APPLICABLE ENG SPEC NOT APPLICABLE SIZE |
|-----|----------|-----------------|-------|----|----|-----|---|--|--|
| A | 07-09-15 | NEW DRAWING | 41458 | HG | RG | AR | | | |
| | | | | | | | NAME DATE DRN H. GUAJALES 07-09-15 CHK R. GUJARDO 07-09-15 ENG A. REARDON 07-09-15 MFG SCALE 0.100 | JOHNSON CONTROLS UNITARY PRODUCTS GROUP NORMAN, OK 73069 | REV A |

Single Package R-410A Heat Pump

Project Name: **Riverbank Community Center**

Unit Model #: **XYE05A1B1AA1A121A3**

Quantity: 1 Tag #: **RTU-2**

System: **XYE05A1B1AA1A121A3**

Cooling Performance

| | |
|------------------------------|-------------|
| Total gross capacity | 50.4 MBH |
| Sensible gross capacity | 36.7 MBH |
| Total net capacity | 47.7 MBH |
| Sensible net capacity | 34.0 MBH |
| Seasonal Efficiency (at ARI) | 15.00 SEER |
| Seasonal Efficiency (at ARI) | 14.40 SEER2 |
| Efficiency (at ARI) | 12.50 EER |
| Efficiency (at ARI) | 12.00 EER2 |
| Ambient DB temp. | 95.0 °F |
| Entering DB temp. | 80.0 °F |
| Entering WB temp. | 67.0 °F |
| Evap Coil Leaving DB temp. | 58.8 °F |
| Evap Coil Leaving WB temp. | 57.0 °F |
| Unit Leaving DB temp. | 60.3 °F |
| Unit Leaving WB temp. | 57.6 °F |
| Leaving air temp dew point | 55.80 °F |
| Power input (w/o blower) | 3.50 kW |
| Sound power | 79 dB(a) |

Refrigerant

| | |
|------------------|--------|
| Refrigerant type | R-410A |
| Sys1 | 14 lb |

Heat Pump Performance

| | |
|-----------------------|-----------|
| Ambient DB temp. | 47 °F |
| Entering DB temp. | 60 °F |
| Leaving DB temp. | 88.2 °F |
| Air temp. rise | 28.2 °F |
| Design Gross Capacity | 48.8 MBH |
| Design Power Input | 3.54 kW |
| HSPF | 8.2 |
| HSPF2 | 7.3 |
| Capacity @ 47(°F) | 46.00 MBH |
| COP @ 47(°F) | 3.60 COP |
| Capacity @ 17(°F) | 27.40 MBH |
| COP @ 17(°F) | 2.30 COP |
| Applied electric heat | 4.9 kW |

Heating Performance

| | |
|-------------------------------|----------|
| Entering DB temp. | 60 °F |
| Heating output capacity (Max) | 16.7 MBH |
| Nominal electric heat | 6.5 kW |
| Applied electric heat | 4.9 kW |
| Installed | Field |
| Supply air | 1600 cfm |
| Leaving DB temp. | 69.7 °F |
| Air temp. rise | 9.7 °F |
| Stages | 1 |

Supply Air Blower Performance

| | |
|---|----------|
| Supply air | 1600 cfm |
| Ext. static pressure | 0.65 IWG |
| Addl. Unit Losses (Options/Accessories) | 0.02 IWG |
| Blower speed | 1120 rpm |
| Max BHP of Motor (including service factor) | 2.40 HP |
| Duct location | Bottom |
| Motor rating | 1.50 HP |
| Actual required BHP | 0.84 HP |
| Power input | 0.78 kW |
| Elevation | 0 ft |
| Drive type | BELT |

Outside/Mixed Air

| | |
|-----------------|---------|
| Outside Air cfm | 425 cfm |
|-----------------|---------|

Electrical Data

| | | |
|----------------------------------|----------|----------|
| Power supply | 208-1-60 | 230-1-60 |
| Unit min circuit ampacity | 63.6 A | 67.7 A |
| Unit min over-current protection | 70 A | 70 A |
| Unit max over-current protection | 70 A | 80 A |

Dimensions & Weight

| | | |
|---------------------------------------|-----------|-----------|
| Hgt 41 in | Len 74 in | Wth 49 in |
| Weight with factory installed options | | 624 lb |

Clearances

| | | | | | |
|-------|-------|-------|-------|------|-------|
| Right | 18 in | Front | 36 in | Rear | 18 in |
|-------|-------|-------|-------|------|-------|



4 Ton

- All units are manufactured at an ISO 9001 registered facility and each rooftop is completely computer-run tested prior to shipment.

Unit Features

- Unit Cabinet Constructed of Powder Painted Steel, Certified At 750 Hours Salt Spray Test (ASTM B-117 Standards)
- Either supply and/or return can be field converted from vertical to horizontal configuration without cutting panels.
- Full perimeter base rails with built in rigging capabilities
- Scroll Compressors
- Medium Static Belt Drive Blower
- Solid Core Liquid Line Filter Driers
- Unit Ships with 2" Throwaway Filters
- Replacement Filters: 4 - (16" x 16")**. Unit accepts 2" or 4" wide filters.
- Single Point Power Connection
- Short Circuit Current: 5kA RMS Symmetrical
- Non-fused Disconnect (60 Amp)
- Copper tube/Aluminum fin Condenser Coil, Copper tube/Aluminum fin Evaporator Coil

BAS Controller

- Smart Equipment Controller including Discharge Air, Return Air, and Outdoor Air Temperature Sensors.

Standard Unit Controller

- On-Board Diagnostic and Fault Code display
- An Integrated Low-Ambient Control, Anti-Short Cycle Protection, Lead-Lag, Fan On and Fan off Delays, Low Voltage Protection, Allows all units to operate in the cooling mode down to 0 °F outdoor ambient without additional components or intervention.
- Safety Monitoring - Monitors the high and low-pressure switches, the freezestats, the gas valve, if applicable, and the temperature limit switch on gas and electric heat units. The unit control board will alarm on ignition failures, safety lockouts and repeated limit switch trips.
- Smart Equipment Control Board

Warranty

- One (1) Year Limited Warranty on the Complete Unit
- Five (5) Year Warranty - Compressors



York® Sun™ Core 3-12.5 Ton Package

Single Package R-410A Heat Pump

Project Name: **Riverbank Community Center**

Unit Model #: **XYE05A1B1AA1A121A3**

Quantity: **1** Tag #: **RTU-2**

System: **XYE05A1B1AA1A121A3**

Top 72 in Bottom 1 in Left 12 in

Note: Please refer to the tech guide for listed maximum static pressures





York® Sun™ Core 3-12.5 Ton Package

Single Package R-410A Heat Pump

Project Name: Riverbank Community Center

Unit Model #: XYE05A1B1AA1A121A3

Quantity: 1 Tag #: RTU-2

System: XYE05A1B1AA1A121A3

Additional Electrical Data

| | |
|---------------------------------------|----------|
| Power supply | 208-1-60 |
| Unit min circuit ampacity | 63.6 A |
| Unit max over-current protection | 70 A |
| Min Voltage | 187 V |
| Max Voltage | 252 V |
| Comp #1 RLA | 19.6 |
| Comp #1 LRA | 130.0 |
| Indoor Mtr Voltage | 208-1-60 |
| Indoor Mtr FLA | 7.6 |
| Outdoor Mtr Qty | 1 |
| Outdoor Fan Voltage | 208-1-60 |
| OD Fan Mtr FLA (ea.) | 2.0 |
| Power Ex Mtr Qty (if applicable) | 1 |
| Powered Ex Voltage(if applicable) | 208-1-60 |
| Power Ex Mtr FLA (ea) (if applicable) | 1.5 |



York® Sun™ Core 3-12.5 Ton Package

Single Package R-410A Heat Pump

Project Name: Riverbank Community Center

Unit Model #: XYE05A1B1AA1A121A3

Quantity: 1 Tag #: RTU-2

System: XYE05A1B1AA1A121A3

Factory Installed Options

XYE05A1B1AA1A121A3

| Equipment Options | Option(s) Selected |
|---------------------------|---|
| Product Category: | XY York Sun Core Single Packaged R-410A High Efficiency Heat Pump |
| Heat Type: | E |
| Nominal Cooling Capacity: | 05 4 Ton 15.0 SEER / 12.5 EER |
| Heat Size: | A |
| Voltage: | 1 208/230-1-60 |
| Airflow: | B Medium Static Belt Drive Blower |
| Airflow Options: | 1 |
| Coil Options: | A Copper tube/Aluminum fin Condenser Coil, Copper tube/Aluminum fin Evaporator Coil |
| Controls: | A Smart Equipment Controller including Discharge Air, Return Air, and Outdoor Air Temperature Sensors. |
| Sensor Options: | 1 |
| Economizer / Damper: | A |
| Convenience Outlet: | 1 |
| Electrical Options: | 2 Non-fused Disconnect (60 Amp) |
| Cabinet Options: | 1 |
| Special Options: | A |
| Product Generation: | 3 |

Field Installed Accessories

- 1BD0409 - Burglar Bars (Small Footprint) (32.0 lbs)
- 1CV0402 - Concentric Diffuser, Flush Mount, 18RD
- 1CV0411 - Concentric Diffuser, Side Discharge, 18RD (55.0 lbs)
- 1CV0419 - Concentric Diffuser, Specialty, 18X18
- 1FA0415 - Manual O.A. Damper with Hood Kit- 0% to 25% Capability Small Footprint 2-position (25.0 lbs)
- 1FA0419 - Manual Fresh Air Damper installed on side-flow RA cover, 0-35%, Small Footprint (25.0 lbs)
- 1HG0420 - Hail Guard Kit (Small Footprint Tall Cabinet) (24.0 lbs)
- 1RC0456 - Curb Rigid 14" (356 mm) Small Footprint (145.0 lbs)
- 1RC0458 - Curb Rigid 24" (610 mm) Small Footprint (135.0 lbs)
- 1TB0401 - Small Footprint Thru The Base Electrical & Thru The Curb Gas (1.0 lbs)
- 1TB0403 - Small Footprint Thru The Base Electrical & Gas (1.0 lbs)
- 2EC0401 - Kit, Single Enthalpy Field Installed (1.0 lbs)
- 2EE04706724 - Economizer, DB, Vertical Flow, Small Footprint (with Barometric Relief) (63.0 lbs)
- 2EK04510625 - 6.5 kW 208/230-3(1)-60 Electric Heat (9.6 lbs)
- 2EK04511125 - 10.5 kW 208/230-3(1)-60 Electric Heat (14.6 lbs)
- 2MD04704224 - Motorized O.A. Damper with Hood Kit- 0% to 100% Capability Small Footprint 0-100% 2-position (36.0 lbs)
- 2MD04704424 - Motorized Fresh Air Damper, 0-35% installed on side flow RA cover, Small Footprint (36.0 lbs)
- 2PM04700224 - Phase Monitor Kit (1.0 lbs)
- 2SD04701124 - Smoke Detector - Return (Downflow Only) (12.0 lbs)



York® Sun™ Core 3-12.5 Ton Package

Single Package R-410A Heat Pump

Project Name: **Riverbank Community Center**

Unit Model #: **XYE05A1B1AA1A121A3**

Quantity: **1** Tag #: **RTU-2**

System: **XYE05A1B1AA1A121A3**

- 2SD04701224 - Smoke Detector - Supply (12.0 lbs)
- 2SD04701324 - Smoke Detector - Supply (Horizontal/Downflow) and Return (Downflow Only) (12.0 lbs)
- S1-03102529000 - Non-Networking Wall Sensor – Allows remote sensing and control from single or multiple zones. (0.2 lbs)
- S1-03102529004 - Non-Networking Wall Sensor with Over-ride button – Allows remote sensing and control from single or multiple zones. Override allows setpoint to be overridden for 2 hour time period. (0.2 lbs)
- S1-ADDWIRE - Add-a-Wire allows 5-wire thermostats to use only 4 wires. (0.3 lbs)
- S1-CTS DTS - CTS Wired Temperature Sensor for thermostat | Duct *Also works for LX Series (0.3 lbs)
- S1-CTS HTS - CTS Hardwired Temperature Sensor for CTS Thermostats *Works with LX series as well (0.2 lbs)
- S1-CTS PLATE - Wall Plate for CTS Thermostats *Also works for new platform LX series models below (0.0 lbs)
- S1-CTS WFTS - CTS Temperature Sensor with WiFi for CTS Thermostats *Also works with LX Series (0.1 lbs)
- S1-LX LOCK - Locking Ring For LX-Series Thermostats (0.4 lbs)
- S1-LX PLATE - Wall Plate For LX-Series Thermostats (0.0 lbs)
- S1-LX WFM - For LX Series Thermostats - WiFi Communication (0.1 lbs)
- S1-MP-PRTKIT-0P - MAP (Multiple Access Portal) Gateway Kit- Replacement MAP gateway protective case, lanyard and communication cable. Use only to replace worn or damaged components. (0.3 lbs)
- S1-MP-STAFBA-0 - Field Bus Adapter (Includes RJ-12 to 4-position Terminal Block Adapter. Used for interfacing directly to MS/TP Field Bus) (1.0 lbs)
- S1-MP-STAKIT-0 - Stationary Cradle Only (Includes mounting bracket and field bus adapter) (0.1 lbs)
- S1-MP-STAKIT-0H - Stationary Cradle Kit (Includes mounting bracket, field bus adapter, and 100-240 VAC line voltage power supply) (1.0 lbs)
- S1-NSB8BHN041-0 - Wall Temperature and 3% Relative Humidity Combined Sensor, No Display, WHITE, NO JCI LOGO, NS8000 Series (0.4 lbs)
- S1-NSB8BHN043-0 - Wall Temperature and 3% Relative Humidity Combined Sensor, No Display, BLACK, NO JCI LOGO, NS8000 Series (0.4 lbs)
- S1-NSB8BHN141-0 - Wall Temperature and 3% Relative Humidity Combined Sensor, Warmer/Cooler Display, WHITE, NO JCI LOGO, NS8000 Series (0.4 lbs)
- S1-NSB8BHN143-0 - Wall Temperature and 3% Relative Humidity Combined Sensor, Warmer/Cooler Display, BLACK, NO JCI LOGO, NS8000 Series (0.4 lbs)
- S1-NSB8BHN240-0 - Zone Temperature Sensor. +3% RH, LCD DISPLAY, LOCAL SETPOINT CONTROL , WHITE, WITH JCI LOGO (0.4 lbs)
- S1-NSB8BHN241-0 - Zone Temperature Sensor. +3% RH, LCD DISPLAY, LOCAL SETPOINT CONTROL , WHITE, NO LOGO (0.4 lbs)
- S1-NSB8BHN243-0 - Wall Temperature and 3% Relative Humidity Combined Sensor, Full Display, BLACK, NO JCI LOGO, NS8000 Series (0.4 lbs)
- S1-NSB8BPN240-0 - Wall Temperature and 2% Relative Humidity Combined Sensor, Full Display, WHITE, JCI LOGO, NS8000 Series (0.4 lbs)
- S1-NSB8BPN241-0 - Wall Temperature and 2% Relative Humidity Combined Sensor, Full Display, WHITE, NO JCI LOGO, NS8000 Series (0.4 lbs)
- S1-NSB8BPN243-0 - Wall Temperature and 2% Relative Humidity Combined Sensor, Full Display, BLACK, NO JCI LOGO, NS8000 Series (0.4 lbs)
- S1-NSB8BTN041-0 - Zone Temperature Sensor Only, NO DISPLAY, NO SETPOINT CONTROL , WHITE, NO LOGO (0.4 lbs)
- S1-NSB8BTN141-0 - Zone Temperature Sensor Only, NO DISPLAY, WARMER/COOLER TEMP. ADJUSTMENT , WHITE, NO LOGO (0.4 lbs)
- S1-NSB8BTN143-0 - Wall Temperature Sensor, Warmer/Cooler Display, BLACK, NO JCI LOGO, NS8000 Series (0.4 lbs)
- S1-NSB8BTN240-0 - Zone Temperature Sensor Only, LCD DISPLAY, LOCAL SETPOINT CONTROL , WHITE, WITH JCI LOGO (0.4 lbs)
- S1-NSB8BTN241-0 - Zone Temperature Sensor Only, LCD DISPLAY, LOCAL SETPOINT CONTROL , WHITE, NO LOGO (0.4 lbs)
- S1-NSB8BTN243-0 - Wall Temperature Sensor, Full Display, BLACK, NO JCI LOGO, NS8000 Series (0.4 lbs)
- S1-SE-COM1001-0 - Field Installed Communication Card for Simplicity SE control. Can be field configurable for BACnet, N2 or ModBUS MSTP (0.0 lbs)
- S1-TBSU305-Y - York Branded LX Series | 3" LCD Display | 3/4 Stage Heating | 2 Stage Cooling | (5+1+1) 7-day Programmable (1.0 lbs)
- S1-TEC3630-14-000 - 7 DAY PROGRAMMABLE THERMOSTAT, OPTIONAL MSTP OR N2 COMMUNICATION, RTU/HEAT PUMP WITH ECON, FULL COLOR, WHITE, NO LOGO (0.8 lbs)
- S1-TL-CWCVT-0 - CWCVT (Connected Workflow Converter) (1.0 lbs)
- S1-YK/AN-RSO-ACI - Non-Networking Wall Sensor with Setpoint Adjustment and Over-ride Button – Allows remote sensing and control from single or multiple zones. (1.0 lbs)



York® Sun™ Core 3-12.5 Ton Package

Single Package R-410A Heat Pump

Project Name: **Riverbank Community Center**

Unit Model #: **XYE05A1B1AA1A121A3**

Quantity: **1** Tag #: **RTU-2**

System: **XYE05A1B1AA1A121A3**

- S1-YK-MAP1810-0P - MAP (Multiple Access Portal) Gateway- For use with SimplicitySE Control. (0.2 lbs)
- S1-YK-MAP1810-0S - Stationary MAP Gateway (Includes MAP Gateway, Field Bus Adapter, Mounting Bracket and 100 to 240 VAC Power Supply). US-compatible counties. (1.9 lbs)
- YCCP050PK012LO - One Year Labor Only AC/HP PKG 1 to 5T
- YCCP050PK012PL - One Year Renewable Parts & Labor AC/HP PKG 1 to 5T
- YCCP050PK060PL - 5 Year Parts and Labor AC/HP PKG 1 to 5T
- YCCP050PK060PO - 5 Year Parts Only (No Compressor Coverage) AC/HP PKG 1 to 5T

Project Name: **Riverbank Community Center**

 Unit Model #: **XYE05A1B1AA1A121A3**

 Quantity: **1** Tag #: **RTU-2**
Consolidated Drawing

- NOTES:
- FOR OUTDOOR USE ONLY.
 - WEIGHTS SHOWN ARE FOR HEAT PUMP UNITS.
 - RECOMMENDED MIN. CLEARANCES:
 RIGHT SIDE: 18 [450] W/SIDE CONDENSATE DRAIN: 24 [600]
 LEFT SIDE: 12 [300] W/P/TAIL: 18 [450]
 FRONT: 36 [900]
 REAR: 18 [450] W/ECONOMIZER/POWER EXHAUST: 36 [900]
 TOP: 72 [1800]
 BOTTOM: 1 [25]
 - FOR SMALLER SERVICE AND OPERATIONAL CLEARANCES CONTACT YOUR APPLICATION ENGINEERING DEPARTMENT.
 - DOWNFLOW DUCTS DESIGNED TO BE ATTACHED TO ACCESSORY ROOF CURB ONLY. IF UNIT IS MOUNTED SIDE SUPPLY, IT IS RECOMMENDED THAT THE DUCTS ARE SUPPORTED BY CROSS BRACES, AS DONE ON ACCESSORY ROOF CURBS.
 - MINIMUM CONDENSATION TRAP HEIGHT SHALL BE 1.5 TIMES THE LOWEST NEGATIVE STATIC.
 - DIMENSIONS IN [] ARE IN MILLIMETERS OR KILOGRAMS.
 - OPTIONAL COIL GUARDS, DISCONNECT SWITCH SHOWN.
 - TOP PANEL EMBOSSEMENTS NOT SHOWN FOR DIMENSION CLARITY.

| TONNAGE | UNIT | OPERATING WEIGHT (LBS) (BASE UNIT) | CENTER OF GRAVITY LOCATION (BASE UNIT) | | 4 POINT CORNER LOADS (LBS) (BASE UNIT) | | | |
|---------|------|------------------------------------|--|--------------|--|------------|------------|----------|
| | | | X | Y | A | B | C | D |
| 4 | XYE | 614 [278.5] | 35.8 [909.3] | 24.2 [614.6] | 155 [70.3] | 146 [66.2] | 151 [68.4] | 161 [73] |
| 5 | XYE | 634 [287.5] | 36.5 [927.1] | 26.2 [665.4] | 171 [77.5] | 166 [75.2] | 147 [66.6] | 150 [68] |

DIRECTION OF AIRFLOW
 CENTER OF GRAVITY

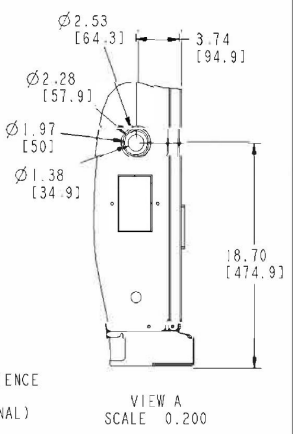
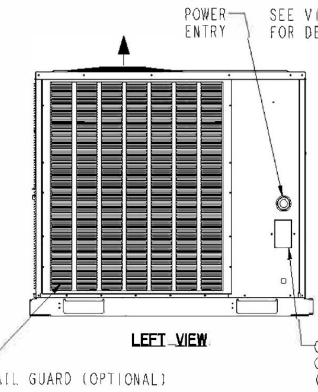
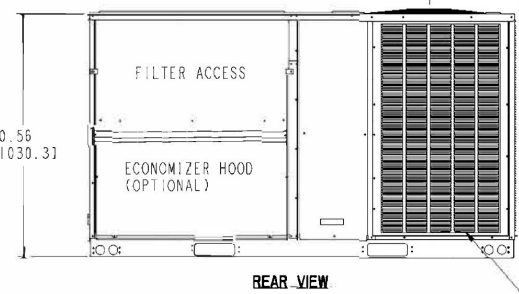
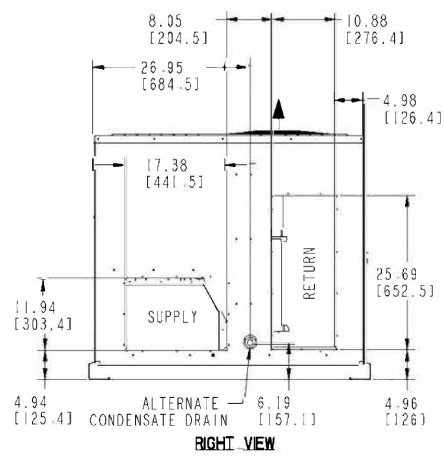
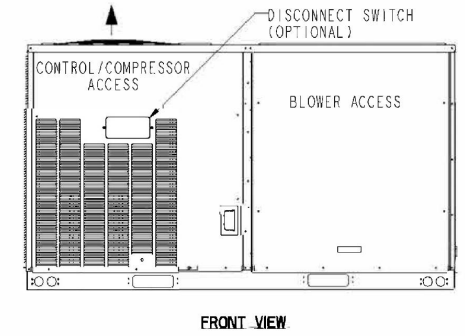
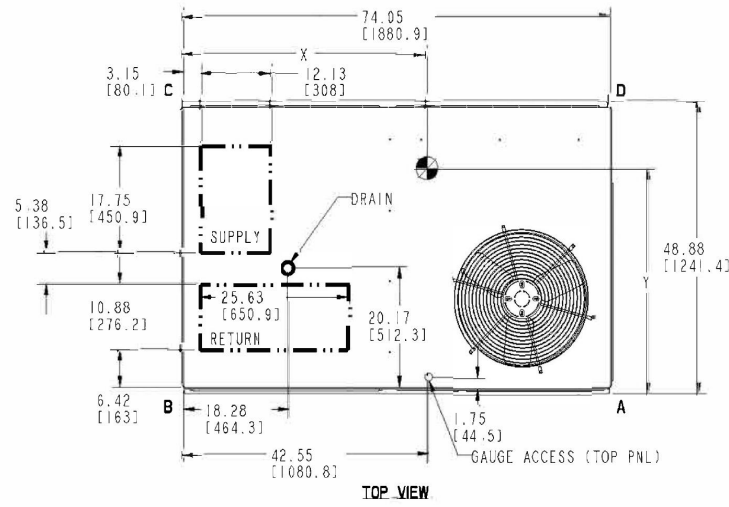

| REV | DATE | REVISION RECORD | EC NO | DR | CK | ENG | THIRD ANGLE PROJECTION | ALL PROPRIETARY RIGHTS IN THE SUBJECT MATTER HEREOF ARE RESERVED AND NO PERMISSION IS GRANTED TO REPRODUCE THIS PRINT IN WHOLE OR IN PART OR DISCLOSE ANY OF THE INFORMATION UPON IT TO OTHERS WITHOUT WRITTEN RELEASE BY JOHNSON CONTROLS | SAFETY AND KEY CHARACTERISTICS PER RE-FDP-STD-01 |
|--|----------|-----------------|-------|----|----|-----|------------------------|--|---|
| A | 07-09-15 | NEW DRAWING | 41458 | HG | RG | AR | | DRAWINGS PER ASME Y14.5M-1994 TOLERANCES UNLESS OTHERWISE SPECIFIED: ONE PLACE DECIMAL = ±.1 TWO PLACE DECIMAL = ±.03 THREE PLACE DECIMAL = ±.010 ANGLES = ±2° DIMENSIONS ARE IN INCHES DO NOT SCALE PRINT | MATERIAL TYPE NOT APPLICABLE ENG SPEC NOT APPLICABLE |
| SUBMITTAL DWG, CDR, I ODF, 40.5" CAB (HP) | | | | | | | | DWS NO: JUST-CDR-IODFSTHP | PART NO. SHT 01 OF 1 |
| JOHNSON CONTROLS UNITARY PRODUCTS GROUP NORMAN, OK 73069 | | | | | | | | SCALE 0.100 | REV A |

DIVISION 23 – HEATING, VENTILATING, AND AIR-CONDITIONING(HVAC)

Number Title

23 00 00 HEATING VENTILATING, AND AIR-CONDITIONING(HVAC)

23 06 00 Schedules for HVAC

23 06 80 Schedules for Decentralized HVAC Equipment

23 06 80. 13 Decentralized Unitary HVAC Equipment Schedule

23 06 80. 13.A Rooftop unit schedule

23 07 00 HVAC Insulation

23 07 16 HVAC Equipment Insulation

23 07 16. 13 Decentralized, Rooftop Units

23 07 16. 13.A Evaporator fan compartment

1. Interior cabinet surfaces shall be insulated with a minimum 1/2- in. thick, minimum 1 1/2 lb density, flexible fiberglass insulation coated on the air side.
2. Insulation and adhesive shall meet NFPA 90A requirements for flame spread and smoke generation.

23 07 16. 13.B Gas heat compartment

1. Aluminum foil-faced fiberglass insulation shall be used.
2. Insulation and adhesive shall meet NFPA 90A requirements for flame spread and smoke generation.

23 09 00 Instrumentation and Control for HVAC

23 09 13 Instrumentation and Control Devices for HVAC

23 09 13. 23 Sensors and Transmitters

23 09 13. 23.A Thermostats

1. Thermostat must:
 - a. energize “G” when calling for fan only or continuous fan.
 - b. have capability to energize 2 different stages of cooling, and 2 different stages of heating.
 - c. include capability for occupancy scheduling.

23 09 23 Direct-digital Control system for HVAC

23 09 23. 13 Decentralized, Rooftop Units

23 09 23. 13.A Smart Equipment (Unit based microprocessor control)

1. Shall be ASHRAE 62-2001 compliant.
2. Shall include an integrated economizer controller to support an economizer with 2 to 10 v DC actuator input.
3. Controller shall accept the following inputs: space temperature, setpoint adjustment, outdoor air temperature, indoor air quality, outdoor air quality, indoor relative humidity, compressor lockout, fire shutdown, enthalpy, fan status, remote time clock/door switch.
4. Shall accept a CO₂ sensor in the conditioned space, and be Demand Control Ventilation ready.
5. Unit shall provide surge protection for the controller through a circuit breaker.
6. Shall have an LED display independently showing the status of activity on the communication bus, and processor operation.
7. Software upgrades will be accomplished by local download. Software upgrades through chip replacements are not allowed.

- A. Unit shall be complete with self-contained low-voltage control circuit protected by a resettable circuit breaker on the 24-volt transformer side.
- B. Unit shall incorporate a lockout circuit which provides reset capability at the space thermostat or base unit should any of the following standard safety devices trip and shut off compressor:
 - C. Loss-of-charge/Low-pressureswitch.
 - D. High-pressure switch.
 - E. Freeze-protection thermostat, evaporator coil. If any of the above safety devices trip, an LED (light-emitting diode) indicator shall flash a diagnostic code that indicates which safety switch has tripped.
- F. Unit shall incorporate "AUTO RESET" compressor over temperature, over current protection.
- G. Unit shall operate with conventional thermostat designs and have a low voltage terminal strip for easy hook-up.
- H. Unit control board shall have on-board diagnostics and fault code display.
- I. Standard controls shall include anti-short cycle and low voltage protection, and permit cooling operation down to 0 °F.
- J. Control board shall monitor each refrigerant safety switch independently.
- K. Control board shall retain last 5 fault codes in non-volatile memory, which will not be lost in the event of a power loss.

23 09 23. 13.B RTU Open-multi-protocol, direct digital controller

- 1. Shall be ASHRAE 62-2001 compliant.
- 2. Shall include built-in protocol for BACNET , Modbus , and Johnson N2.
- 3. Shall allow access of up to 62 network variables (SNVT). Shall be compatible with all open controllers
- 4. Baud rate Controller shall be selectable using a dip switch.
- 5. Shall have an LED display independently showing the status of serial communication,running, errors, power, all digital outputs, and all analog inputs.
- 6. Shall accept the following inputs: space temperature, setpoint adjustment, outdoor air temperature, indoor air quality, outdoor air quality, compressor lock- out, fire shutdown, enthalpy switch, and fan status/filter status/ humidity/ remote occupancy.
- 7. Software upgrades will be accomplished by either local or remote download. No software upgrades through chip replacements are allowed.

23 09 33 Electric and Electronic Control System for HVAC

23 09 33. 13 Decentralized, Rooftop Units

23 09 33. 13.A General

- 1. Shall be complete with self- contained low- voltage control circuit protected by a resettable circuit breaker on the 24-v transformer side. Transformer shall have 75VA capability.
- 2. Shall utilize color-coded wiring.
- 3. Shall include a central control terminal board to conveniently and safely provide connection points for vital control functions such as: smoke detectors, phase monitor, gas controller, economizer, thermostat, DDC control options, and low and high pressure switches.
- 4. The heat exchanger shall be controlled by an integrated gas controller (IGC) microprocessor. See heat exchanger section of this specification.

23 09 33. 23.B Safeties

- 1. Compressor over-temperature, over-current. High internal pressure differential.
- 2. Low-pressure switch.
 - a. Units with 2 compressors shall have different sized connectors for the circuit 1 and circuit 2 **low and high** pressure switches. They shall physically prevent the cross- wiring of the safety switches between circuits 1 and 2.
 - b. Low pressure switch shall use different color wire than the high pressure switch. The purpose is to assist the installer and service technician to correctly wire and or troubleshoot the rooftop unit.
- 3. High pressure switch.
 - a. Units with 2 compressors shall have different sized connectors for the circuit 1 and circuit 2 **low and high** pressure switches. They shall physically prevent the cross-wiring of the safety switches between circuits 1 and 2.

- b. High pressure switch shall use different color wire than the low pressure switch. The purpose is to assist the installer and service technician to correctly wire and or troubleshoot the rooftop unit.

- 4. Automatic reset,/motor thermal overload protector.

23 09 93 Sequence of Operations for HVAC Controls

23 09 93. 13 Decentralized, Rooftop Units

23 09 93. 13 INSERT SEQUENCE OF OPERATION

23 40 13 Panel Air Filters

23 40 13. 13 Decentralized, Rooftop Units

23 40 13. 13.A Standard filter section

- 1. Shall consist of factory-installed, low velocity, disposable 2" or 4" thick fiberglass filters of commercially available sizes.
- 2. Units can accept 2" or 4" filters and have a field convertible toolless
- 3. Filters shall be accessible through an access panel with toolless removal as described in the unit cabinet section of this specification (23 81 19.13.H).

23 81 19 Self-Contained Air Conditioners

23 81 19. 13 Small-Capacity Self-Contained Air Conditioners

23 81 19. 13.A General

- 1. Outdoor, rooftop mounted, electrically controlled, heating and cooling unit utilizing a fully hermetic scroll compressor(s) for cooling duty
- 2. Factory assembled, single-piece heating and cooling rooftop unit. Contained within the unit enclosure shall be all factory wiring, piping, controls, and special features required prior to field start-up.
- 3. Unit shall be installed in accordance with the manufacturer's instructions.
- 4. Unit must be selected and installed in compliance with local, state, and federal codes.

23 81 19. 13.B Quality Assurance

- 1. Unit meets ASHRAE 90.1 minimum efficiency requirements.
- 3. Unit shall be rated in accordance with AHRI Standards 210/240 and 340/360.
- 4. Unit shall be designed to conform to ASHRAE 15, 2001.
- 5. Unit shall be UL- tested and certified in accordance with ANSI Z21.47 -2012/CSA 2.3-2012, CSA C22.2 No. 236-11 (UL 1995) 4th edition and CSA C22.2 No. 3 - M 1988
- 6. Insulation and adhesive shall meet NFPA 90A requirements for flame spread and smoke generation.
- 7. Unit casing shall be capable of withstanding 750-hour salt spray exposure per ASTM B117 (scribed specimen).
- 8. Unit shall be designed in accordance with ISO 9001, and shall be manufactured in a facility registered by; ISO 9001.
- 9. Roof curb shall be designed to conform to NRCA Standards.
- 10. Unit shall be subjected to a completely automated run test on the assembly line. The data for each unit; will be stored at the factory, and must be available upon request.
- 11. Unit shall be designed in accordance with UL Standard 1995, including tested to withstand rain.
- 12. Unit shake tested to assurance level 1, ASTM D4169 to ensure shipping reliability.
- 13. High Efficient Motors listed shall meet section 313 of the Energy Independence and Security Act of 2007; (EISA 2007).

23 81 19. 13.B Delivery, Storage, and Handling

- 1. Unit shall be stored and handled per manufacturer's recommendations.

23 81 19. 13.E Project Conditions

- 1. As specified in the contract.

23 81 19. 13.F Operating Characteristics

- 1. Unit shall be capable of starting and running at 125°F (52°C) ambient outdoor temperature, meeting maximum load criteria of AHRI Standard 210/240 or 340/360 at ± 10% voltage.

2. Compressor with standard controls shall be capable of operation down to 0°F (2°C), ambient outdoor temperatures. See below for head pressure control package or winter start kit.
 3. Unit shall discharge supply air vertically or horizontally as shown on contract drawings.
 4. Unit shall be factory configured for vertical supply & return configurations.
 5. Unit shall be field convertible from vertical to horizontal airflow on all models.
 6. Unit shall be capable of mixed operation: vertical supply with horizontal return or horizontal supply with vertical return.
- 23 81 19. 13.G Electrical Requirements
1. Main power supply voltage, phase, and frequency must match those required by the manufacturer.
- 23 81 19. 13.H Unit Cabinet
1. **Unit cabinet shall be constructed of galvanized steel with exterior surfaces coated with a non-chalking, powder paint finish, certified at 750 hour salt spray test per ASTM-B117 standards.**
 2. Evaporator fan compartment interior cabinet insulation shall conform to AHRI Standards 210/240 or 340/360 minimum exterior sweat criteria. Interior surfaces shall be insulated with a minimum 1/2- in. thick, 1 1/2 lb density, flexible fiberglass insulation, neoprene coated on the air side. Aluminum foil- faced fiberglass insulation shall be used in the gas heat compartment. Fan shall be a belt drive assembly and include an adjustable pitch motor pulley. Job site selected brake horsepower shall not exceed the motors nameplate horsepower rating plus the service factor (Only premium efficiency motors have hp rating on the nameplate). Units shall be designed to operate within the service factor. Fan wheel shall be double inlet type with forward curve blades, dynamically balanced to operate smoothly throughout the entire range of operation. Airflow design shall be constant volume. Bearings shall be sealed and permanently lubricated for longer life and no maintenance.

Condenser Fan Assembly: The outdoor fans shall be of the direct drive type, discharge air vertically, have aluminum blades riveted to corrosion resistant steel spider brackets and shall be dynamically balanced for smooth operation. The outdoor fan motors shall have permanently lubricated bearings internally protected against overload conditions and staged independently.
 3. Base of unit shall have a minimum of four locations for thru-the-base gas and electrical connections (factory installed or field installed), standard.
 4. Base Rail
 - a. Unit shall have base rails on a minimum of 4 sides.
 - b. Holes shall be provided in the base rails for rigging shackles to facilitate maneuvering and overhead rigging.
 - c. Holes shall be provided in the base rail for moving the rooftop by fork truck..
 - d. Base rail shall be a minimum of 16 gauge thickness.
 5. Condensate pan and connections
 - a. Shall be an internally sloped condensate drain pan made of a non-corrosive material.
 - b. Shall comply with ASHRAE Standard 62.
 - c. Shall use a 3/4" - 14 NPT drain connection, possible either through the bottom or side of the drain pan. Connection shall be made per manufacturer's recommendations.
 6. Top panel
 - a. Shall be a single piece top panel.
 8. Electrical Connections
 - a. All unit power wiring shall enter unit cabinet at a single, factory-prepared, knockout location.
 - b. Thru-the-base capability.
 - (1.) Standard unit shall have a thru-the-base electrical location(s) using a raised, embossed portion of the unit basepan.
 - (2.) Optional, factory- approved, water-tight connection method must be used for thru-the-base electrical connections.
 - (3.) No basepan penetration, other than those authorized by the manufacturer, is permitted.
 9. Component access panels (standard)
 - a. Cabinet panels shall be easily removable for servicing.
 - b. Unit shall have one factory installed, toolless, removable, filter access panel.
 - c. Panels covering control box, indoor fan, indoor fan motor, gas components(where applicable), and compressors shall have a molded composite handles.
 - d. Handles shall be UV modified, composite. They shall be permanently attached, and recessed into the panel.

- e. Screws on the vertical portion of all removable access panel shall engage into heat resistant, molded composite collars.
 - f. Collars shall be removable and easily replaceable using manufacturer recommended parts.
- 23 81 19. 13.J Coils
- 1. Standard Aluminum Fin/Copper Tube Coils
 - a. Standard evaporator and condenser coils shall have aluminum lanced plate fins mechanically bonded to seamless internally grooved copper tubes with all joints brazed.
 - b. Evaporator coils shall be leak tested to 150 psig, pressure tested to 450 psig, and qualified to CSA C22.2 No. 236-11 (UL 1995) 4th edition burst test at 1775 psig.
 - c. Condenser coils shall be leak tested to 150 psig, pressure tested to 650 psig, and qualified to CSA C22.2 No. 236-11 (UL 1995) 4th edition burst test at 1980 psig.
- 23 81 19. 13.K Refrigerant Components
- 1. Refrigerant circuit shall include the following control, safety, and maintenance features
 - a. Thermostatic Expansion Valve (TXV) shall help provide optimum performance across the entire operating range. Shall contain removable power element to allow change out of power element and bulb without removing the valve body.(Orifice on ZX08, ZX09, ZX12, ZQ04, ZQ05 & ZQ06)
 - b. Refrigerant filter drier - Solid core design.
 - c. Service gauge connections on suction and discharge lines.
 - d. Pressure gauge access through a specially designed access port in the top panel of the unit.
 - 2. There shall be gauge line access port in the skin of the rooftop, covered by a black, removable plug.
 - a. The plug shall be easy to remove and replace.
 - b. When the plug is removed, the gauge access port shall enable maintenance personnel to route their pressure gauge lines.
 - c. This gauge access port shall facilitate correct and accurate condenser pressure readings by enabling the reading with the compressor access panel on.
 - d. The plug shall be made of a leak proof, UV- resistant, composite material.
 - 3. Compressors
 - a. Unit shall use fully hermetic, scroll compressor for each independent refrigeration circuit.
 - b. Compressor motors shall be cooled by refrigerant gas passing through motor windings.
 - c. Compressors shall be internally protected from high discharge temperature conditions.
 - d. Compressors shall be protected from an over-temperature and over-amperage conditions by an internal, motor overload device.
 - e. Compressor shall be factory mounted on rubber grommets.
 - f. Compressor motors shall have internal line break thermal, current overload and high pressure differential protection.
 - g. Crankcase heaters shall not be required for normal operating range, unless provided by the factory.
- 23 81 19. 13.L Filter Section
- 1. Filters access is specified in the unit cabinet section of this specification.
 - 2. Shall consist of factory-installed, low velocity, throw-away 2" or 4" thick fiberglass filters.
 - 3. Units can accept 2" or 4" filters and have a field convertible toolless
- 23 81 19. 13.M Evaporator Fan and Motor
- 1. Evaporator fan motor
 - a. Shall have permanently lubricated bearings.
 - b. Shall have inherent automatic reset thermal protection (Only on single-phase, belt-drive motors, three - phase, belt-drive motors have internal thermostat used for external line-break control.).
 - 3. Belt-driven Evaporator Fan
 - a. Belt drive shall include an adjustable-pitch motor pulley.
 - b. Shall use sealed, permanently lubricated ball-bearing type.
 - c. Blower fan shall be double-inlet type with forward-curved blades.
 - d. Shall be constructed from steel with a corrosion resistant finish and dynamically balanced.

23 81 19. 13.N Condenser Fans and Motors

The outdoor fans shall be of the direct drive type, discharge air vertically, have aluminum blades riveted to corrosion resistant steel spider brackets and shall be dynamically balanced for smooth operation. The outdoor fan motors shall have permanently lubricated 60°C ball bearings internally protected against overload conditions and staged independently. A cleaning window shall be provided on two sides of the units for coil cleaning.

1. Condenser fan motors
 - a. Shall be a totally enclosed motor.
 - b. Shall use permanently lubricated bearings.
 - c. Shall have inherent thermal overload protection with an automatic reset feature.
 - d. All models shall use a shaft-down design except shaft-up on ZX14 & ZY12 size with rain shield.
2. Condenser Fans
 - a. Shall be a direct-driven propeller type fan.
 - b. Shall have aluminum blades riveted to corrosion-resistant steel spiders and shall be dynamically balanced.

23 81 19. 13.O Special Features Options and Accessories

7. Condenser Coil Hail Guard Assembly (Factory installed option on 3-phase models. Field installed on all 3 and 1 phase models):
 - a. Shall protect against damage from hail.
 - b. Shall be of louvered style.
8. Unit- Mounted, Non-Fused Disconnect Switch: (Verify on the unit nameplate that the disconnect is properly sized for the application. Units with field installed electric heat may exceed the factory installed disconnect amperage rating.)
 - a. Switch shall be factory- installed, internally mounted.
 - b. National Electric Code (NEC) and UL approved non- fused switch shall provide unit power shutoff.
 - c. Shall be accessible from outside the unit.
 - d. Shall provide local shutdown and lockout capability.

Date

07/16/2024

Project Name

Riverbank Community Center

Project Number

Client / Purchaser



Control Summary Page

| Control | Models and Unit Tags | |
|-----------------------------|----------------------|-------|
| Standard Simplicity Control | XYE04A1B1AA1A121A3 | RTU-1 |
| | XYE05A1B1AA1A121A3 | RTU-2 |

23 09 23 Direct- digital Control system for HVAC23 09 23. 13 Decentralized, Rooftop Units:23 09 23. 13.A. Unit Control Board

1. ASHRAE 62- 2001 compliant. BTL certified.
2. Shall accept 20-30 VAC input power, 50/60Hz. 24 VAC nominal.
3. Operating temperature range from -40F to 158F; 10-90% RH (non-condensing UI), and -4F to 158F; 10-90% Rh (non-condensing), with a storage temperature range from -40F to 194F; 5-95% RH (non-condensing).
4. Shall include an option of and Economizer microprocessor controller which communicates directly with the Unit Control Board and has 8 Analog outputs, 2 Analog inputs, 2 Binary outputs, 3 Binary outputs.
5. Controller shall accept the following inputs: space temperature, return air temperature sensor, setpoint adjustment, outdoor air temperature, indoor air quality, outdoor air quality, indoor relative humidity, compressor lock- out, fire/smoke shutdown, single and dual enthalpy, fan status, remote time clock, SA Bus communicated temperature/humidity/CO2 values from Network sensors, FC Bus Network Overrides for space temperature, outdoor air temperature, space humidity, outdoor air quality, Indoor air quality, System purge.
6. Shall accept a single CO₂ sensor or multiple CO₂ sensors networked together via communication bus in the conditioned space, and be Demand Control Ventilation (DCV) ready.
7. Shall provide the following outputs: economizer, fan, cooling stage 1, cooling stage 2, heat stage 1, heat stage 2, heat stage 3/ exhaust/ reversing valve/ dehumidify/occupied.
8. Unit shall provide surge protection for the controller through a circuit breaker.
9. Shall be Internet capable, and communicate at a Baud rate of 38.4K or faster.
10. Shall have an LED display independently showing the status of activity on the communication bus, and processor operation.
11. Unit shall incorporate a lockout circuit which provides reset capability at the space thermostat or base unit should any of the following standard safety devices trip and shut off compressor. If any of these safety devices trip, the LCD screen will display alarm message indicating the specific safety device that caused the lockout.
 - a. Loss of charge/Low-pressure switch.
 - b. High-pressure switch.
 - c. Freeze condition sensor on evaporator coil.
12. Unit control board must support each usage case:
 - a. Conventional thermostat with low voltage input terminals for easy installation
 - b. Communicating network sensors in the occupied space to provide feedback on space conditions for unit control board to compare with associated setpoints
 - c. Communication via BACnet MS/TP, Modbus RTU, N2 protocols for integration into a building automation/management system
13. Anti-short cycle and low voltage protection features included.
14. Internal occupied/unoccupied scheduling
15. Unit control board shall permit cooling operation down to a selectable value as low as 0 degrees F.
16. Shall allow for start-up, commissioning, troubleshooting, parameter adjustment, setpoint adjustment via onboard display and navigable menu with no additional interface tool or controls technician required.
17. The unit control board shall run a self-test diagnostics algorithm at startup that operated the cooling cycle, heating cycle, fan operation. A status report shall be provided upon completion of the diagnostic self-test.
18. Utilize any wi-fi enabled smart device to access the HVAC or multiple HVAC units if communication wiring between them is present (FC Bus or SA Bus). Remote access shall allow complete ability to perform start-up, commissioning, troubleshooting, parameter adjustment, setpoint adjustment.
19. Local embedded trending and scheduling. Trending data and occupancy scheduling predefined from the factory. Occupancy schedule to be modified via control board joystick menu navigation and remotely using a smart device (cellular phone, laptop, tablet)
20. A menu on the onboard screen shall display the unit status and allow changing parameters where applicable. These include but are not limited to:
 - a. Demand Ventilation Mode – enable or disable
 - b. Operational Setpoint – display current value
 - c. Supply Air Temperature (SAT) – display current value
 - d. Return Air Temperature (RAT) – display current value

- e. Operational Supply Humidity (OprSH) – display current value as provided by a 0-10VDS input, SA Bus Network Sensor, or FC Bus communicated value
 - f. Return Air Humidity (RAH) – display current value
 - g. Operational outdoor Air Temperature (OprOAT) – enthalpy calculated from OAH 0-10VDC input to Economizer board and OprOAT only if economizer is present
 - h. Operational Outdoor Air Humidity (OprOAH) – the buffered outdoor air humidity. May be from economizer boards OAH 0-10VDC input or FC Bus communicated value
 - i. Operational outdoor Air Quality (OprOAQ) – the buffered outdoor air quality in use. May be from economizer boards OAQ 0-10VDC input or FC Bus communicated value
 - j. Operational Indoor Air Quality (OprIAQ) – the buffered indoor air quality in use. May be from economizer board IAQ 0-10VDC input, SA Bus Network Sensor, or FC Bus communicated value
21. A menu shall display and allow modification to the following operations and settings:
- a. HVAC Zone Fan
 - b. Cooling
 - c. Heating
 - d. Economizer
 - e. Demand Ventilation
 - f. Power Exhaust
 - g. Sensors
 - h. Network
22. A menu shall display and allow modification to the following operations and settings:
- a. HVAC Zone – Occupied status
 - b. Indoor Fan status
 - c. Cooling status
 - d. Heating status
 - e. Economizer indication whether free-cooling is available or not
 - f. Enabling or disabling of Demand Ventilation
 - g. Power Exhaust
 - 1) Enable/disable hot-gas reheat if available
 - 2) Warmup/Cooldown
 - 3) Title 24 Load Shed
 - 4) Defrost
23. A menu shall display and allow modification to the following operations and settings:
- a. Firmware version (of UCB, Economizer, other peripheral boards)
 - b. Setting time zone
 - c. Network information
 - 1) Device name that will appear on the FC Bus
 - 2) Selection of communication protocol
 - 3) Operational Baud Rate
 - 4) Device ID
24. A menu shall display and allow modification to the following operations and settings:
- a. Version of firmware
 - b. Ability to Load new firmware
 - c. Create a backup file of the firmware and parameter setting via USB port
 - d. Restore factory default parameter values and setup
 - e. Full and Partial Cloning of parameter setpoints from or to other units
 - f. Data trend exporting
25. A menu shall display and allow modification to the following operations and settings:

- a. Unit serial number, model number and name
- b. Ability to reset Lockouts
- c. Controller name
- d. Displays the current values of all setpoints in use
- e. Displays all current values for the indoor and outdoor zones
- f. Displays current values related to:
 - 1) Indoor Fan
 - 2) Cooling
 - 3) Heating
 - 4) Heat Pump operation
 - 5) Economizer operation
 - 6) Power Exhaust
 - 7) Demand Ventilation
 - 8) Air monitoring station
 - 9) Hot Gas Reheat
 - 10) Smoke Control
- g. Current information for inputs; including
 - 1) Sensors
 - 2) Coil Sensors
 - 3) Thermostat
 - 4) Binary Inputs
 - 5) Unit Protection
 - 6) Network Inputs
 - 7) All outputs (relay and binary)
- h. Self-Test
 - 1) A patented self-test system that runs through a series of algorithms to provide a report of all functioning characteristics of the system at time of startup and commissioning.

23 09 23. 13.B. Auxiliary Control Boards

1. ASHRAE 62- 2001 compliant. BTL certified.
2. Economizer controller CEC Title 24 Compliant
 - a. Display alarms if the following occur
 - 1) Economizer is economizing when conditions do not support
 - 2) Economizer is not economizing when conditions do support
 - 3) Damper Stuck
 - 4) Excess Outdoor Air
 - 5) Failed Sensor
3. Refrigeration Fault Detection & Diagnostics
 - a. There is insufficient refrigerant in any circuit
 - b. There is excessive refrigerant in any circuit
 - c. There is excessive refrigerant flow
 - d. There is insufficient refrigerant flow (restriction)
 - e. Inefficient compressor
 - f. Insufficient High-side heat transfer
 - g. Excessive High-side heat transfer (low ambient control problem, low ΔP)
 - h. Insufficient Low-side heat transfer
 - i. Excessive Low-side heat transfer

- j. Sensor fault- The liquid temperature is greater than the condenser temperature (Could also be triggered if refrigerant level is very low in the system)
- k. Sensor fault- Sensor data is not available
- l. The unit is off
- m. The ambient temperature is too low
- n. The ambient temperature is too high
- o. The return air wet-bulb temperature is too low
- p. The return air wet-bulb temperature is too high
- q. Sensor fault- The condensing temperature is lower than the ambient temperature (Could also be triggered when the condenser is wet)
- r. The suction line temperature is less than the evaporator temperature
- s. The evaporator temperature is greater than the ambient temperature
- t. The liquid temperature is lower than the ambient temperature
- u. Sensor fault- Suction temperature or ambient temperature is invalid
- v. Sensor fault- The return air dry-bulb or wet-bulb temperature is invalid
- w. Sensor fault- The liquid pressure or suction pressure is invalid
- x. Sensor fault- The suction line temperature is invalid
- y. The return air dry-bulb temperature is too low
- z. The return air dry-bulb temperature is too high
- aa. The Efficiency Index is below 75% of ideal
- bb. The Capacity Index is below 75% of ideal

23 09 23. 13.C Remote Accessibility:

1. ASHRAE 62- 2001 compliant. BTL certified.
2. Provide the ability to adjust parameter values, setpoints, limits remotely
3. Connectivity to an Ethernet network via static IP address or Dynamic Name Server (DNS)
4. Allow a maximum of 100 devices on the same FC bus trunk and accessed by one remote device

Start-up sheet

START-UP & SERVICE DATA INSTRUCTION**COMMERCIAL PACKAGE UNITS****3.0 To 50.0 TONS****START-UP CHECKLIST**

Date: _____

Job Name: _____

Customer Name: _____

Address: _____

City: _____ State: _____ Zip: _____

Model Number: _____ Serial Number: _____

Qualified Start-up Technician: _____ Signature: _____

HVAC Contractor: _____ Phone: _____

Address: _____

Contractor's E-mail Address: _____

Electrical Contractor: _____ Phone: _____

Distributor Name: _____ Phone: _____

WARRANTY STATEMENT

Johnson Controls/Ducted Systems is confident that this equipment will operate to the owner's satisfaction if the proper procedures are followed and checks are made at initial start-up. This confidence is supported by the 30 day dealer protection coverage portion of our standard warranty policy which states that Johnson Controls/Ducted Systems will cover parts and labor on new equipment start-up failures that are caused by a defect in factory workmanship or material, for a period of 30 days from installation. Refer to the current standard warranty policy and warranty manual for details.

In the event that communication with Johnson Controls/Ducted Systems is required regarding technical and/or warranty concerns, all parties to the discussion should have a copy of the equipment start-up sheet for reference. A copy of the original start-up sheet should be filed with the Technical Services Department.

The packaged unit is available in constant or variable air volume versions with a large variety of custom options and accessories available. Therefore, some variation in the startup procedure will exist depending upon the products capacity, control system, options and accessories installed.

This start-up sheet covers all startup check points common to all package equipment. In addition it covers essential startup check points for a number of common installation options. Depending upon the particular unit being started not all sections of this startup sheet will apply. Complete those sections applicable and use the notes section to record any additional information pertinent to your particular installation.

Warranty claims are to be made through the distributor from whom the equipment was purchased.

EQUIPMENT STARTUP

Use the local LCD or Mobile Access Portal (MAP) Gateway to complete the start-up.

A copy of the completed start-up sheet should be kept on file by the distributor providing the equipment and a copy sent to:

Johnson Controls/Ducted Systems
 Technical Services Department
 5005 York Drive
 Norman, OK 73069

SAFETY WARNINGS

The inspections and recording of data outlined in this procedure are required for start-up of Johnson Controls/Ducted Systems' packaged products. Industry recognized safety standards and practices must be observed at all times. General industry knowledge and experience are required to assure technician safety. It is the responsibility of the technician to assess all potential dangers and take all steps warranted to perform the work in a safe manner. By addressing those potential dangers, prior to beginning any work, the technician can perform the work in a safe manner with minimal risk of injury.

| |
|---|
| ⚠ WARNING |
| Lethal voltages are present during some start-up checks. Extreme caution must be used at all times. |

| |
|--|
| ⚠ WARNING |
| Moving parts may be exposed during some startup checks. Extreme caution must be used at all times. |

NOTE: Read and review this entire document before beginning any of the startup procedures.

DESIGN APPLICATION INFORMATION

This information will be available from the specifying engineer who selected the equipment. If the system is a VAV system the CFM will be the airflow when the remote VAV boxes are in the

full open position and the frequency drive is operating at 60 HZ. **Do not proceed with the equipment start-up without the design CFM information.**

Design Supply Air CFM: _____ Design Return Air CFM: _____

Design Outdoor Air CFM At Minimum Position: _____

Total External Static Pressure: _____

Supply Static Pressure: _____

Return Static Pressure: _____

Design Building Static Pressure: _____

Outside Air Dilution: Economizer Position Percentage: _____ CFM: _____

Supply Gas Pressure After Regulator W/o Heat Active _____ Inches _____

ADDITIONAL APPLICATION NOTES FROM SPECIFYING ENGINEER:

REFERENCE

| General Inspection | Completed | See Notes |
|---|--------------------------|--------------------------|
| Unit inspected for shipping, storage, or rigging damage | <input type="checkbox"/> | <input type="checkbox"/> |
| Unit installed with proper clearances | <input type="checkbox"/> | <input type="checkbox"/> |
| Unit installed within slope limitations | <input type="checkbox"/> | <input type="checkbox"/> |
| Refrigeration system checked for gross leaks (presence of oil) | <input type="checkbox"/> | <input type="checkbox"/> |
| Terminal screws and wiring connections checked for tightness | <input type="checkbox"/> | <input type="checkbox"/> |
| Filters installed correctly and clean | <input type="checkbox"/> | <input type="checkbox"/> |
| Economizer hoods installed in operating position | <input type="checkbox"/> | <input type="checkbox"/> |
| Condensate drain trapped properly, refer to Installation Manual | <input type="checkbox"/> | <input type="checkbox"/> |
| Economizer damper linkage tight | <input type="checkbox"/> | <input type="checkbox"/> |
| Gas Heat vent hood installed | <input type="checkbox"/> | <input type="checkbox"/> |
| All field wiring (power and control) complete | <input type="checkbox"/> | <input type="checkbox"/> |

| Air Moving Inspection | Completed | See Notes |
|---|--------------------------|--------------------------|
| Alignment of drive components | <input type="checkbox"/> | <input type="checkbox"/> |
| Belt tension adjusted properly | <input type="checkbox"/> | <input type="checkbox"/> |
| Blower pulleys tight on shaft, bearing set screws tight, wheel tight to shaft | <input type="checkbox"/> | <input type="checkbox"/> |
| Pressure switch or transducer tubing installed properly | <input type="checkbox"/> | <input type="checkbox"/> |

| Exhaust Inspection Powered <input type="checkbox"/> Barometric Relief <input type="checkbox"/> | Completed | See Notes |
|--|--------------------------|--------------------------|
| Check hub for tightness | <input type="checkbox"/> | <input type="checkbox"/> |
| Check fan blade for clearance | <input type="checkbox"/> | <input type="checkbox"/> |
| Check for proper rotation | <input type="checkbox"/> | <input type="checkbox"/> |
| Check for proper mounting (screen faces towards unit) | <input type="checkbox"/> | <input type="checkbox"/> |
| Prove operation by increasing minimum setting on economizer | <input type="checkbox"/> | <input type="checkbox"/> |

| Economizer Inspection Standard <input type="checkbox"/> BAS <input type="checkbox"/> | Completed | See Notes |
|---|--------------------------|--------------------------|
| CO ₂ sensor installed Yes <input type="checkbox"/> No <input type="checkbox"/> | <input type="checkbox"/> | <input type="checkbox"/> |
| Check economizer setting (Reference Smart Equipment™ Control Board LCD menu location) | <input type="checkbox"/> | <input type="checkbox"/> |
| Prove economizer open/close through Smart Equipment™ Board Setting | <input type="checkbox"/> | <input type="checkbox"/> |

| Reheat Mode Normal <input type="checkbox"/> or Alternate <input type="checkbox"/> Not Applicable <input type="checkbox"/> |
|---|
| Humidity Sensor (2SH0401) _____ |

Operating Measurements - Air Flow

Fan operates with proper rotation (All VFD equipped units with the optional Manual Bypass must be phased for correct blower rotation with the Bypass switch set in the LINE position) ID Fans Exh. Fans Cond. Fans

| | |
|---|-----|
| Pressure drop across dry evaporator coil (At maximum design CFM) ¹ | IWC |
| External Static Pressure | IWC |
| Return Static Pressure | IWC |
| Supply Static Pressure | IWC |
| Supply Air CFM Using Dry Coil Chart | CFM |
| Final Adjusted Supply Air CFM ² | CFM |

1. Consult the proper airflow to pressure drop table to obtain the actual airflow at the measured pressure differential.
2. Was a motor pulley adjustment or change required to obtain the correct airflow?
 Was it necessary to increase or decrease the airflow to meet the design conditions?
 If the motor pulley size was changed, measure the outside diameters of the motor and blower pulleys and record those diameters here:
 Blower Motor HP _____ FLA _____ RPM _____
 Pulley Pitch Diameter _____ Turns Out _____ Final Turns Out _____
 Blower Pulley Pitch Diameter _____ Fixed Sheave _____

ELECTRICAL DATA

T1 - T2 _____ Volts T2 - T3 _____ Volts
 Control Voltage _____ Volts T1 - T3 _____ Volts

| Device | Nameplate | Measured List All Three Amperages |
|---------------------------------|-----------|--------------------------------------|
| Supply Fan Motor ^{1,2} | AMPS | AMPS |
| Exhaust Motor (Dampers 100%) | AMPS | AMPS |
| Condenser Fan #1 | AMPS | AMPS |
| Condenser Fan #2 (if equipped) | AMPS | AMPS |
| Condenser Fan #3 (if equipped) | AMPS | AMPS |
| Condenser Fan #4 (if equipped) | AMPS | AMPS |
| Compressor #1 | AMPS | AMPS |
| Compressor #2 (if equipped) | AMPS | AMPS |
| Compressor #3 (if equipped) | AMPS | AMPS |
| Compressor #4 (if equipped) | AMPS | AMPS |

1. VAV units with heat section - simulate heat call to drive VAV boxes and VFD/IGV to maximum design airflow position.
2. VAV units without heat section - VAV boxes must be set to maximum design airflow position.

