

---

# SUBMITTAL DATA

**Order #:**

**Date:** 01/06/2022

**Project:** 3507 - Port Neches, TX

**Project #:**

**Submitter:** Ted Spring  
UPG National Accounts-York  
5005 York Dr.,  
Norman, Oklahoma 73069

**Date**

01/06/2022

**Project Name**

3507 - Port Neches, TX

**Project Number****Client / Purchaser**

## Submittal Summary Page

Qty	Tag #	Model # / Material #	Description
1	RTU-1	ZT180N30R4B5GCB2C1	<p>15 Ton, York Large Sunline Single Packaged R-410A Air Conditioner, Three Stage Cooling, 12.0 EER, 300 MBH Input Aluminized Steel, Two Stage Gas Heat, 460-3-60, Single Wall Construction</p> <ul style="list-style-type: none"> <li>• IntelliSpeed control of the VFD based on stages of cooling. Provides Single Zone VAV Fan Operation as defined by ASHRAE 90.1 section 6.4.3.10.</li> <li>• Dry Bulb Low Leak Economizer w/Barometric Relief and Hoods (Bottom Return Only) with Economizer Fault Detection &amp; Diagnostic (Meets ASHRAE 90.1-2013, IECC 2015, California Title 24, AMCA 511)</li> <li>• 7.5 HP High Static Belt Drive Blower</li> <li>• 2" Pleated Filters (MERV 8)</li> <li>• Smart Equipment Controller including Discharge Air, Return Air, and Outdoor Air Temperature Sensors. BACNet MS/TP, Modbus and N2 Communication Card.</li> <li>• Non Powered Convenience Outlet (110 VAC)</li> <li>• HACR Circuit Breaker/Disconnect</li> <li>• Supply Air Smoke Detector</li> <li>• Phase Monitor</li> <li>• Electrofin Condenser Coil</li> <li>• Standard Evaporator Coil</li> <li>• Hinged &amp; Tool Free Filter, Blower, Motor and Electrical Access Panels</li> <li>• Galvanized Steel Drain Pan</li> </ul>
1	RTU-1	2AQ04700524	CO <sup>2</sup> Space Sensor - Wall Mount Accessory
1	RTU-1	2EC0402	Kit, Dual Enthalpy Field Installed (Includes two humidity sensors)
1	RTU-2	ZT120N18R4B5GCL2R1	<p>10 Ton, Single Packaged R-410A Ultra High Efficiency Air Conditioner, Three Stage Cooling, 13.1 EER, 180 MBH Input Aluminized Steel, Two Stage Gas Heat, 460-3-60</p> <ul style="list-style-type: none"> <li>• Dry Bulb Low Leak Economizer w/Barometric Relief and Hoods (Bottom or Horizontal End Return Only) with Economizer Fault Detection &amp; Diagnostic (Meets ASHRAE 90.1-2013, IECC 2015, California Title 24, AMCA 511).</li> <li>• VFD Standard</li> <li>• 3 HP High Static Belt Drive Blower</li> <li>• 2" Pleated Filters (MERV 8)</li> <li>• IntelliSpeed control of the VFD based on stages of cooling (Provides Single Zone VAV Fan Operation as defined by ASHRAE 90.1 section 6.4.3.10)</li> <li>• Smart Equipment Controller including Discharge Air, Return Air,</li> </ul>

Qty	Tag #	Model # / Material #	Description
			and Outdoor Air Temperature Sensors. BACNet MS/TP, Modbus and N2 Communication Card. <ul style="list-style-type: none"> <li>• Non-Powered Convenience Outlet</li> <li>• HACR Circuit Breaker/Disconnect</li> <li>• Supply Air Smoke Detector</li> <li>• Phase Monitor</li> <li>• E-Coat Condenser Coil</li> <li>• Micro-Channel "all-aluminum" condenser coil, Copper tube/aluminum fin evaporator coil</li> <li>• MagnaDry Reheat</li> <li>• Composite Drain Pan - Back Connection</li> </ul>
1	RTU-2	2EC0402	Kit, Dual Enthalpy Field Installed (Includes two humidity sensors)
1	RTU-3	ZJ061N08D4B5GCB2R3	5 Ton, Single Packaged R-410A Air Conditioner, High Efficiency, Single Stage Cooling, 14.5 SEER / 12.2 EER, 80 MBH Input Aluminized Steel, Two Stage Gas Heat, 460-3-60 <ul style="list-style-type: none"> <li>• Dry Bulb Low Leak Economizer w/Barometric Relief and Hoods (Bottom or Horizontal End Return Only) with Economizer Fault Detection &amp; Diagnostic (Meets ASHRAE 90.1-2013, IECC 2015, California Title 24, AMCA 511).</li> <li>• 2 HP High Static Belt Drive Blower</li> <li>• 2" Pleated Filters (MERV 8)</li> <li>• Smart Equipment Controller including Discharge Air, Return Air, and Outdoor Air Temperature Sensors. BACNet MS/TP, Modbus and N2 Communication Card.</li> <li>• Non-Powered Convenience Outlet</li> <li>• HACR Circuit Breaker/Disconnect</li> <li>• Supply Air Smoke Detector</li> <li>• Phase Monitor</li> <li>• E-Coat Condenser Coil</li> <li>• Micro-Channel "all-aluminum" condenser coil, Copper tube/aluminum fin evaporator coil</li> <li>• Composite Drain Pan - Back Connection</li> </ul>
1	RTU-3	2AQ04700524	CO <sup>2</sup> Space Sensor - Wall Mount Accessory
1	RTU-3	2EC0402	Kit, Dual Enthalpy Field Installed (Includes two humidity sensors)
1		ADAPTER PACKAGE	AES CURB ADAPTER PACKAGE

Equipment start-up and commissioning by a factory trained technician is recommended.  
Contact your supplying distributor or sales representative for additional information & guidance.



WARNING: Cancer and Reproductive Harm - [www.P65Warnings.ca.gov](http://www.P65Warnings.ca.gov)

Project Name: **3507 - Port Neches, TX**

Unit Model #: **ZT180N30R4B5GCB2C1**

Quantity: **1** Tag #: **RTU-1**

System: **ZT180N30R4B5GCB2C1**

### Cooling Performance

Total gross capacity	172.1 MBH
Sensible gross capacity	121.7 MBH
Total net capacity	161.9 MBH
Sensible net capacity	111.5 MBH
Efficiency (at ARI)	12.00 EER
Integrated eff. (at ARI)	18.00 IEER
Ambient DB temp.	95.0 °F
Entering DB temp.	78.0 °F
Entering WB temp.	64.8 °F
Leaving DB temp.	54.9 °F
Leaving WB temp.	52.9 °F
Leaving air temp dew point	51.40 °F
Power input (w/o blower)	12.03 kW
Sound power	79 dB(A)

### Refrigerant

Refrigerant type	R-410A
Sys1	23 lbs 8 oz
Sys2	24 lbs

### Gas Heating Performance

Entering DB temp.	60 °F
Heating output capacity (Max)	240 MBH
Supply air	4875 CFM
Heating input capacity (Max)	300 MBH
Leaving DB temp.	105.6 °F
Air temp. rise	45.6 °F
SSE	80.0 %
Stages	2

### Supply Air Blower Performance

Supply air	4875 CFM
Ext. static pressure	1.5 IWG
Addl. Unit Losses (Options/Accessories)	0.1 IWG
Blower speed	912 RPM
Max BHP of Motor (including service factor)	8.63 HP
Duct location	Bottom
Motor rating	7.50 HP
Actual required BHP	3.22 HP
Power input	3.00 kW
Elevation	0 ft.
Drive type	BELT

### Outside/Mixed Air

Outside Air Cfm	725 CFM
Outside Air DB temp.	95 °F
Outsided Air WB temp.	78 °F
Outside Air RH	47.3 %
Return Air CFM	4150 CFM
Return Air DB temp.	75 °F
Return Air WB temp.	62 °F
Return Air RH	48.1 %

### Electrical Data

Power supply	460-3-60
Unit min circuit ampacity	37.7 Amps
Unit max over-current protection	45 Amps

### Dimensions & Weight

Hgt	53 in.	Len	181 in.	Wth	92 in.
Weight with factory installed options	2999 lbs.				

### Clearances

Right	36 in.	Front	36 in.	Rear	49 in.
Top	72 in.	Bottom	0 in.	Left	24 in.

Note: Please refer to the tech guide for listed maximum static pressures



### 15 Ton

- York Sunline Units are Manufactured at an ISO 9001 Registered Facility and Each Rooftop is Completely Computer-Run Tested Prior to Shipment.

### Unit Features

- Three Stage Cooling
- 300 MBH Input Aluminized Steel, Two Stage Gas Heat
- Unit Cabinet Constructed of Powder Painted Steel, Certified At 750 Hours Salt Spray Test (ASTM B-117 Standards).
- Either Supply and/or Return can be Field Converted from Vertical to Horizontal Configuration without Cutting Panels
- Full Perimeter Base Rails with Built in Rigging Capabilities
- Dry Bulb Low Leak Economizer w/Barometric Relief and Hoods (Bottom Return Only) with Economizer Fault Detection & Diagnostic (Meets ASHRAE 90.1-2013, IECC 2015, California Title 24, AMCA 511)
- 7.5 HP High Static Belt Drive Blower
- 2" Pleated Filters (MERV 8)
- Solid Core Liquid Line Filter Driers
- Replacement Filters: For 2" filters 12 - (12" x 24" x 2") OR For 4" filters 2 - (20" X 24" x 4") AND 4 - (24" X 24" x 4")
- Non Powered Convenience Outlet (110 VAC)
- Single Point Power Connection
- Through-the-Curb and Through-The-Base Utility Connections
- HACR Circuit Breaker/Disconnect
- Short Circuit Current: 5kA RMS Symmetrical
- Supply Air Smoke Detector
- Phase Monitor
- Electrofin Condenser Coil
- Standard Evaporator Coil
- Crane Required to Unload Unit
- Galvanized Steel Drain Pan
- Hinged & Tool Free Filter, Blower, Motor and Electrical Access Panels

### BAS Controller

- IntelliSpeed control of the VFD based on stages of cooling. Provides Single Zone VAV Fan Operation as defined by ASHRAE 90.1 section 6.4.3.10.
- Smart Equipment Controller including Discharge Air, Return Air, and Outdoor Air Temperature Sensors. BACNet MS/TP, Modbus and N2 communication card.

### Standard Unit Controller: Smart Equipment Control Board

- An Integrated Low-Ambient Control, Anti-Short Cycle Protection, Lead-Lag, Fan On and Fan off Delays, Low Voltage Protection, On-Board Diagnostic and Fault Code Display. Allows all units to operate in the cooling mode down to 0 °F outdoor ambient without additional components or intervention.
- Safety Monitoring - Monitors the High and Low-Pressure Switches, the Freezestats, the Gas Valve, if Applicable, and the Temperature Limit Switch on Gas and Electric Heat Units. The Unit Control Board will Alarm on Ignition Failures, Safety Lockouts and Repeated Limit Switch Trips.

### Warranty

- One (1) Year Limited Warranty on the Complete Unit





# 15-25 Sunline Magnum

Project Name: **3507 - Port Neches, TX**

Unit Model #: **ZT180N30R4B5GCB2C1**

Quantity: **1** Tag #: **RTU-1**

System: **ZT180N30R4B5GCB2C1**

- Three (3) Year Warranty – ElectroFin Condenser Coil
- Five (5) Year Warranty - Compressors and Electric Heater Elements
- Ten (10) Year Warranty - Aluminized Steel Tubular Heat Exchangers



Project Name: 3507 - Port Neches, TX

Unit Model #: ZT180N30R4B5GCB2C1

Quantity: 1 Tag #: RTU-1

System: ZT180N30R4B5GCB2C1

**Additional Electrical Data**

Power supply	460-3-60
Unit min circuit ampacity	37.7 Amps
Unit max over-current protection	45 Amps
Min Voltage	432 V
Max Voltage	504 V
Comp #1 RLA	9.6
Comp #1 LRA	84
Comp #2 RLA	9.6
Comp #2 LRA	84
Indoor Mtr Voltage	460-3-60
Indoor Mtr FLA	9.7
Outdoor Mtr Qty	4
Outdoor Fan Voltage	460-1-60
OD Fan Mtr FLA (ea.)	1.6
Power Ex Mtr Qty	1
Powered Ex Voltage	460-1-60
Power Ex Mtr FLA (ea)	2.2
Combustion Mtr Qty	1
Combustion Motor Voltage	460-1-60
Combustion Mtr FLA (ea)	0.3

Project Name: 3507 - Port Neches, TX

Unit Model #: ZT180N30R4B5GCB2C1

Quantity: 1 Tag #: RTU-1

System: ZT180N30R4B5GCB2C1

## Factory Installed Options

### ZT180N30R4B5GCB2C1

Equipment Options	Option(s) Selected
Product Category:	<b>ZT</b> York Large Sunline Single Packaged R-410A Air Conditioner 12.0 EER
Nominal Cooling Capacity:	<b>180</b> 15 Ton Three Stage Cooling
Heat Type and Nominal Heat Capacity:	<b>N30</b> 300 MBH Input Aluminized Steel, Two Stage Gas Heat
Blower Option:	<b>R</b> IntelliSpeed control of the VFD based on stages of cooling. Provides Single Zone VAV Fan Operation as defined by ASHRAE 90.1 section 6.4.3.10. 7.5 HP High Static Belt Drive Blower
Voltage:	<b>4</b> 460-3-60
Outside Air Option:	<b>B</b> Dry Bulb Low Leak Economizer w/Barometric Relief and Hoods (Bottom Return Only) with Economizer Fault Detection & Diagnostic (Meets ASHRAE 90.1-2013, IECC 2015, California Title 24, AMCA 511)
Service Options:	<b>5</b> Non Powered Convenience Outlet (110 VAC) HACR Circuit Breaker/Disconnect
Sensor Options:	<b>G</b> Supply Air Smoke Detector Phase Monitor
Controls:	<b>C</b> Smart Equipment Controller including Discharge Air, Return Air, and Outdoor Air Temperature Sensors. BACNet MS/TP, Modbus and N2 Communication Card.
Refrigeration:	<b>B</b> Electrofin Condenser Coil Standard Evaporator Coil
Additional Options:	<b>2</b> 2" Pleated Filters (MERV 8)
Cabinet Options:	<b>C</b> Single Wall Construction Hinged & Tool Free Filter, Blower, Motor and Electrical Access Panels Galvanized Steel Drain Pan
Product Generation:	<b>1</b>

### Field Installed Accessories

- |   |  |   |
|---|--|---|
| <input type="radio"/> 1BD0404 - Burglar Bars (51.0 lbs)                 | <input type="radio"/> 1CV0415 - Concentric Diffuser, Side Discharge, 18X36 | <input type="radio"/> 1CV0422 - Concentric Diffuser, Specialty, 30X30 |
| <input type="radio"/> 1CG0421 - Coil Guard (15.0 lbs)                   | <input type="radio"/> 1CV0416 - Concentric Diffuser, Side Discharge, 24X48 | <input type="radio"/> 1CV0423 - Concentric Diffuser, Specialty, 36X36 |
| <input type="radio"/> 1CV0406 - Concentric Diffuser, Flush Mount, 18X36 | <input type="radio"/> 1CV0421 - Concentric Diffuser, Specialty, 28X28      | <input type="radio"/> 1CV0427 - Concentric Diffuser, Specialty, 28X28 |
| <input type="radio"/> 1CV0407 - Concentric Diffuser, Flush Mount, 24X28 |  |   |

Project Name: **3507 - Port Neches, TX**

Unit Model #: **ZT180N30R4B5GCB2C1**

Quantity: **1** Tag #: **RTU-1**

System: **ZT180N30R4B5GCB2C1**

- 1FE0410 - Flue Extension Kit (37.0 lbs)
- 1GP0403 - Gas Piping Kit (11.0 lbs)
- 1HG0412 - Hail Guard Kit (48.0 lbs)
- 1LD0413 - High Speed Drive - Includes blower pulley and belt for higher CFM and/or static pressure requirements. (9.0 lbs)
- 1NP0418 - Natural Gas to Propane Conversion Kit (2-Stage) (1.0 lbs)
- 1RC0437 - Roof Curb - 14" High, Flat, Uninsulated, Full Perimeter (Shipped Knocked Down) (185.0 lbs)
- 1RC0497 - Roof Curb 14" High Full Perimeter Transition Curb with wood nailer. Allow replacement of ZF180 / J15ZF / ZS-15 / ZST15 with other Large Sunline product. (135.0 lbs)
- 1WS0404 - Wood Skid - Allows unit to be handled with 90 inch forks (210.0 lbs)
- 2AP0402 - Air Proving Switch (1.0 lbs)
- 2AQ04700524 - CO<sup>2</sup> Space Sensor - Wall Mount Accessory (5.0 lbs)
- 2AQ04700624 - CO<sup>2</sup> Unit Mount Accessory (4.6 lbs)
- 2EC0401 - Kit, Single Enthalpy Field Installed (1.0 lbs)
- 2EC0402 - Kit, Dual Enthalpy Field Installed (Includes two humidity sensors) (1.0 lbs)
- 2PE04703446 - Power Exhaust Kit- 460-3-60 with Barometric Relief and Exhaust Hood (Downflow Unit or Horizontal Duct Mounted) (245.0 lbs)
- 2SD04700724 - Smoke Detector Kit w/ Mounting Hardware for Supply or Return Air (Horizontal/Downflow) (17.0 lbs)
- S1-03102529000 - Non-Networking Wall Sensor – Allows remote sensing and control from single or multiple zones. (0.2 lbs)
- S1-03102529004 - Non-Networking Wall Sensor with Over-ride button – Allows remote sensing and control from single or multiple zones. Override allows setpoint to be overridden for 2 hour time period. (0.2 lbs)
- S1-03102529006 - Non-Networking Wall Sensor with Setpoint Adjustment and Over-ride Button – Allows remote sensing and control from single or multiple zones. Allows setpoint to be adjusted ± 5° F. Override allows setpoint to be overridden for 2 hour time period. (0.2 lbs)
- S1-ADDWIRE - Add-a-Wire allows 5-wire thermostats to use only 4 wires. (0.3 lbs)
- S1-CTS DTS - CTS Wired Temperature Sensor for thermostat | Duct \*Also works for LX Series (0.3 lbs)
- S1-CTS HTS - CTS Hardwired Temperature Sensor for CTS Thermostats \*Works with LX series as well (0.2 lbs)
- S1-CTS PLATE - Wall Plate for CTS Thermostats \*Also works for new platform LX series models below (0.0 lbs)
- S1-CTS WFTS - CTS Temperature Sensor with WiFi for CTS Thermostats \*Also works with LX Series (0.1 lbs)
- S1-LX LOCK - Locking Ring For LX-Series Thermostats (0.4 lbs)
- S1-LX PLATE - Wall Plate For LX-Series Thermostats (0.0 lbs)
- S1-LX WFM - For LX Series Thermostats - WiFi Communication (1.0 lbs)
- S1-MP-PRTKIT-0P - MAP (Multiple Access Portal) Gateway Kit- Replacement MAP gateway protective case, lanyard and communication cable. Use only to replace worn or damaged components. (0.3 lbs)
- S1-NSB8BHN041-0 - Wall Temperature and 3% Relative Humidity Combined Sensor, No Display, WHITE, NO JCI LOGO, NS8000 Series (0.4 lbs)
- S1-NSB8BHN043-0 - Wall Temperature and 3% Relative Humidity Combined Sensor, No Display, BLACK, NO JCI LOGO, NS8000 Series (0.4 lbs)
- S1-NSB8BHN141-0 - Wall Temperature and 3% Relative Humidity Combined Sensor, Warmer/Cooler Display, WHITE, NO JCI LOGO, NS8000 Series (0.4 lbs)
- S1-NSB8BHN143-0 - Wall Temperature and 3% Relative Humidity Combined Sensor, Warmer/Cooler Display, BLACK, NO JCI LOGO, NS8000 Series (0.4 lbs)
- S1-NSB8BHN240-0 - Wall Temperature and 3% Relative Humidity Combined Sensor, Full Display, WHITE, JCI LOGO, NS8000 Series (0.4 lbs)
- S1-NSB8BHN241-0 - Wall Temperature and 3% Relative Humidity Combined Sensor, Full Display, BLACK, NO JCI LOGO, NS8000 Series (0.4 lbs)
- S1-NSB8BHN243-0 - Wall Temperature and 3% Relative Humidity Combined Sensor, Full Display, WHITE, JCI LOGO, NS8000 Series (0.4 lbs)
- S1-NSB8BPN240-0 - Wall Temperature and 2% Relative Humidity Combined Sensor, Full Display, WHITE, JCI LOGO, NS8000 Series (0.4 lbs)
- S1-NSB8BPN241-0 - Wall Temperature and 2% Relative Humidity Combined Sensor, Full Display, WHITE, NO JCI LOGO, NS8000 Series (0.4 lbs)
- S1-NSB8BPN243-0 - Wall Temperature and 2% Relative Humidity Combined Sensor, Full Display, BLACK, NO JCI LOGO, NS8000 Series (0.4 lbs)
- S1-NSB8BTN041-0 - Wall Temperature Sensor, No Display, WHITE, NO JCI LOGO, NS8000 Series (0.4 lbs)
- S1-NSB8BTN043-0 - Wall Temperature Sensor, No Display, BLACK, NO JCI LOGO, NS8000 Series (0.4 lbs)
- S1-NSB8BTN141-0 - Wall Temperature Sensor, Warmer/Cooler Display, WHITE, NO JCI LOGO, NS8000 Series (0.4 lbs)
- S1-NSB8BTN143-0 - Wall Temperature Sensor, Warmer/Cooler Display, BLACK, NO JCI LOGO, NS8000 Series (0.4 lbs)
- S1-NSB8BTN240-0 - Wall Temperature Sensor, Full Display, WHITE, JCI LOGO, NS8000 Series (0.4 lbs)

Project Name: 3507 - Port Neches, TX

Unit Model #: ZT180N30R4B5GCB2C1

Quantity: 1 Tag #: RTU-1

System: ZT180N30R4B5GCB2C1

- S1-NSB8BTN241-0 - Wall Temperature Sensor, Full Display, WHITE, NO JCI LOGO, NS8000 Series (0.4 lbs)
- S1-NSB8BTN243-0 - Wall Temperature Sensor, Full Display, BLACK, NO JCI LOGO, NS8000 Series (0.4 lbs)
- S1-TEC3030-14-000 - 7 DAY PROGRAMMABLE THERMOSTAT, ZIGBEE PRO WIRELESS COMMUNICATION, RTU/HEAT PUMP WITH ECON, FULL COLOR, WHITE, JCI LOGO (0.8 lbs)
- S1-TEC3030-16-000 - 7 DAY PROGRAMMABLE THERMOSTAT, ZIGBEE PRO WIRELESS COMMUNICATION, RTU/HEAT PUMP WITH ECON, AND FULL COLOR, WHITE, NO LOGO (0.8 lbs)
- S1-TEC3031-14-000 - 7 DAY PROGRAMMABLE THERMOSTAT, ZIGBEE PRO WIRELESS COMMUNICATION, RTU/HEAT PUMP WITH ECON, OCC SENSOR, FULL COLOR, WHITE, JCI LOGO (0.8 lbs)
- S1-TEC3031-16-000 - 7 DAY PROGRAMMABLE THERMOSTAT, ZIGBEE PRO WIRELESS COMMUNICATION, RTU/HEAT PUMP WITH ECON, OCC SENSOR, FULL COLOR, WHITE, NO LOGO (0.8 lbs)
- S1-TEC3630-14-000 - 7 DAY PROGRAMMABLE THERMOSTAT, OPTIONAL MSTP OR N2 COMMUNICATION, RTU/HEAT PUMP WITH ECON, FULL COLOR, WHITE, JCI LOGO (0.8 lbs)
- S1-TEC3630-16-000 - 7 DAY PROGRAMMABLE THERMOSTAT, OPTIONAL MSTP OR N2 COMMUNICATION, RTU/HEAT PUMP WITH ECON, FULL COLOR, WHITE, NO LOGO (0.8 lbs)
- S1-TEC3631-14-000 - 7 DAY PROGRAMMABLE THERMOSTAT, OPTIONAL MSTP OR N2 COMMUNICATION, RTU/HEAT PUMP WITH ECON, OCC SENSOR, FULL COLOR, WHITE, JCI LOGO (0.8 lbs)
- S1-TEC3631-16-000 - 7 DAY PROGRAMMABLE THERMOSTAT, OPTIONAL MSTP OR N2 COMMUNICATION, RTU/HEAT PUMP WITH ECON, OCC SENSOR, FULL COLOR, WHITE, NO LOGO (0.8 lbs)
- S1-YK-MAP1810-0P - MAP (Multiple Access Portal) Gateway- For use with SimplicitySE Control. (0.2 lbs)
- S1-YK-MAP1810-0S - Stationary MAP Gateway (Includes MAP Gateway, Field Bus Adapter, Mounting Bracket and 100 to 240 VAC Power Supply). US-compatible counties. (1.9 lbs)

Project Name: 3507 - Port Neches, TX

Unit Model #: ZT180N30R4B5GCB2C1

Quantity: 1 Tag #: RTU-1

### Consolidated Drawing

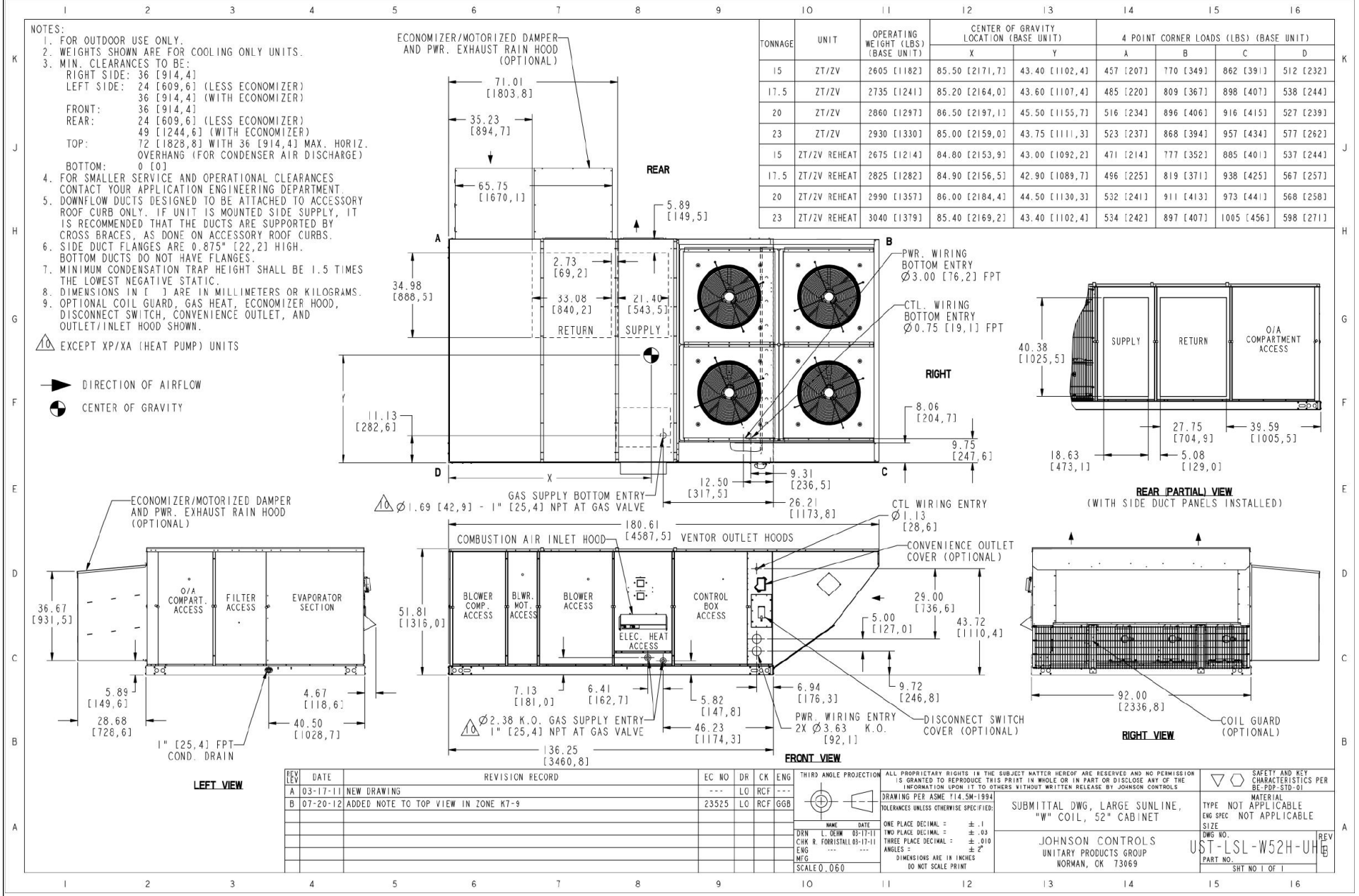

Project Name: 3507 - Port Neches, TX

Unit Model #: ZT180N30R4B5GCB2C1

Quantity: 1 Tag #: RTU-1

**Typical Application**

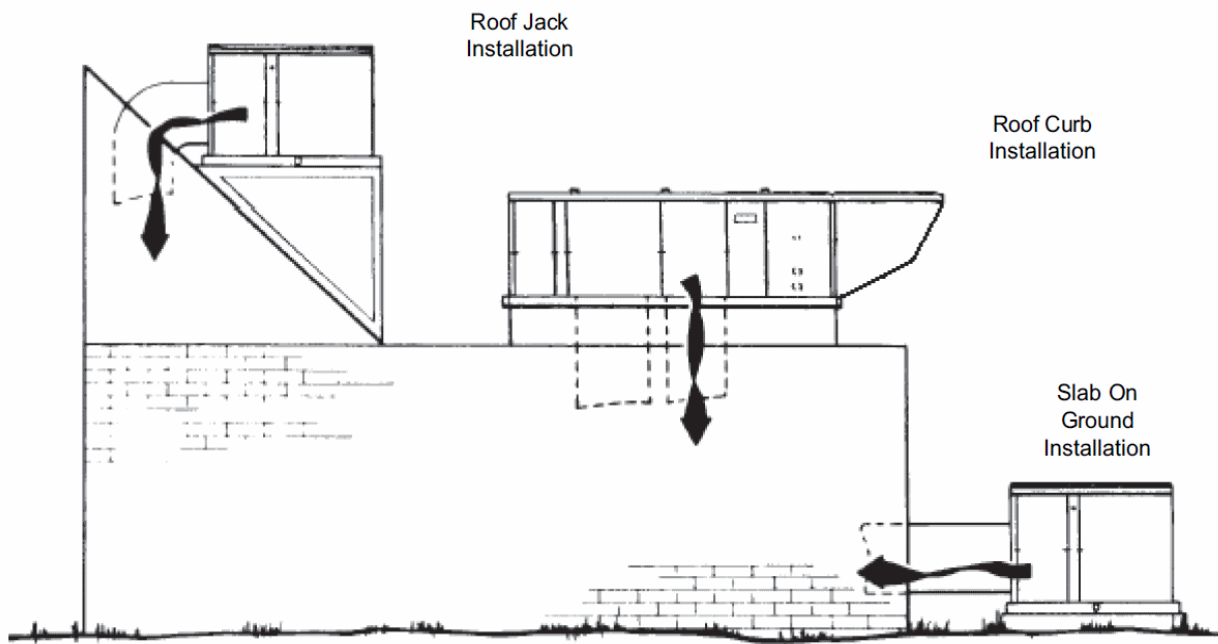

## Single Package R-410A Air Conditioner

Project Name: 3507 - Port Neches, TX

Unit Model #: ZT120N18R4B5GCL2R1

Quantity: 1 Tag #: RTU-2

System: ZT120N18R4B5GCL2R1

### Cooling Performance

Total gross capacity	118.3 MBH
Sensible gross capacity	85.1 MBH
Total net capacity	111.7 MBH
Sensible net capacity	78.5 MBH
Efficiency (at ARI)	13.10 EER
Integrated eff. (at ARI)	21.20 IEER
Ambient DB temp.	95.0 °F
Entering DB temp.	79.0 °F
Entering WB temp.	65.7 °F
Leaving DB temp.	54.8 °F
Leaving WB temp.	53.6 °F
Leaving air temp dew point	52.70 °F
Power input (w/o blower)	7.19 kW
Sound power	82 dB(A)

### Refrigerant

Refrigerant type	R-410A
Sys1	8 lbs 8 oz
Sys2	7 lbs 12 oz

### Reheat Performance

Total capacity	43.5 MBH
Sensible capacity	16 MBH
Ambient DB temp.	85 °F
Entering DB temp.	75 °F
Entering WB temp.	67 °F
Leaving DB temp.	70.4 °F
Leaving WB temp.	63.0 °F
Power input (w/o blower)	4.10 kW
Gallons of water per hour	3.14 gal/hr

### Gas Heating Performance

Entering DB temp.	60 °F
Heating output capacity (Max)	144 MBH
Supply air	3250 CFM
Heating input capacity (Max)	180 MBH
Leaving DB temp.	101.0 °F
Air temp. rise	41.0 °F
SSE	80.0 %
Stages	2

### Supply Air Blower Performance

Supply air	3250 CFM
Ext. static pressure	0.6 IWG
Addl. Unit Losses (Options/Accessories)	0.43 IWG
Blower speed	1018 RPM
Max BHP of Motor (including service factor)	3.45 HP
Duct location	Bottom
Motor rating	3.00 HP
Actual required BHP	2.09 HP
Power input	1.95 kW
Elevation	0 ft.
Drive type	BELT

### Outside/Mixed Air

Outside Air Cfm	650 CFM
Outside Air DB temp.	95 °F
Outsided Air WB temp.	78 °F
Outside Air RH	47.3 %
Return Air CFM	2600 CFM
Return Air DB temp.	75 °F
Return Air WB temp.	62 °F
Return Air RH	48.1 %

### Electrical Data

Power supply	460-3-60
Unit min circuit ampacity	28.2 Amps
Unit max over-current protection	35 Amps

### Dimensions & Weight

Hgt	51 in.	Len	120 in.	Wth	59 in.
Weight with factory installed options	1676 lbs.				

### Clearances

Right	12 in.	Front	36 in.	Rear	36 in.
Top	72 in.	Bottom	0 in.	Left	36 in.

Note: Please refer to the tech guide for listed maximum static pressures



### 10 Ton

- York Sun Pro units are manufactured at an ISO 9001 registered facility and each rooftop is completely computer-run tested prior to shipment.

### Unit Features

- Three Stage Cooling
- 180 MBH Input Aluminized Steel, Two Stage Gas Heat
- Unit Cabinet Constructed of Powder Painted Steel, Certified At 750 Hours Salt Spray Test (ASTM B-117 Standards)
- Full perimeter base rails with built in rigging capabilities
- Scroll Compressor[s]
- Dry Bulb Low Leak Economizer w/Barometric Relief and Hoods (Bottom or Horizontal End Return Only) with Economizer Fault Detection & Diagnostic (Meets ASHRAE 90.1-2013, IECC 2015, California Title 24, AMCA 511).
- VFD Standard
- Slide-out Blower/3 HP Belt Drive Motor Assembly
- Unit Ships with 2" Pleated Filters (MERV 8)
- Solid Core Liquid Line Filter Driers
- Replacement Filters: 4 - (24" x 20"). Unit accepts 2" or 4" wide filters.
- Non-Powered Convenience Outlet
- Short Circuit Current: 5kA RMS Symmetrical
- Single Point Power Connection
- Through-the-Curb and Through-the-Base Utility Connections
- HACR Circuit Breaker/Disconnect
- Supply Air Smoke Detector
- E-Coat Condenser Coil
- Micro-Channel "all-aluminum" condenser coil, Copper tube/aluminum fin evaporator coil
- Crankcase heaters standard
- MagnaDry Reheat
- Composite Drain Pan - Back Connection
- Tool-free maintenance with features like hinged doors for all-access panels, slide-out blower and blower motor tray

### BAS Controller

- IntelliSpeed control of the VFD based on stages of cooling. Provides Single Zone VAV Fan Operation as defined by ASHRAE 90.1 section 6.4.3.10.
- Smart Equipment Controller including Discharge Air, Return Air, and Outdoor Air Temperature Sensors. BACNet MS/TP, Modbus and N2 communication card.

### Standard Unit Controller: Smart Equipment Control Board

- Safety Monitoring - Monitors the High and Low-Pressure Switches, the Freezestats, the Gas Valve, if Applicable, and the Temperature Limit Switch on Gas and Electric Heat Units. The Unit Control Board will Alarm on Ignition Failures, Safety Lockouts and Repeated Limit Switch Trips.

### Warranty

- One (1) Year Limited Warranty on the Complete Unit
- Three (3) Year Warranty - ElectroFin Condenser Coil
- Five (5) Year Warranty - Compressors and Electric Heater Elements



# York® Sun™ Pro 3-12.5 Ton Package

Single Package R-410A Air Conditioner

Project Name: 3507 - Port Neches, TX

Unit Model #: ZT120N18R4B5GCL2R1

Quantity: 1 Tag #: RTU-2

System: ZT120N18R4B5GCL2R1

- Ten (10) Year Limited Warranty - Aluminized Steel Heat Exchanger





# York® Sun™ Pro 3-12.5 Ton Package

Single Package R-410A Air Conditioner

Project Name: 3507 - Port Neches, TX

Unit Model #: ZT120N18R4B5GCL2R1

Quantity: 1 Tag #: RTU-2

System: ZT120N18R4B5GCL2R1

### Additional Electrical Data

Power supply	460-3-60
Unit min circuit ampacity	28.2 Amps
Unit max over-current protection	35 Amps
Min Voltage	432 V
Max Voltage	504 V
Comp #1 RLA	7.6
Comp #1 LRA	52
Comp #2 RLA	7.6
Comp #2 LRA	52
Indoor Mtr Voltage	460-3-60
Indoor Mtr FLA	4.7
Outdoor Mtr Qty	4
Outdoor Fan Voltage	460-1-60
OD Fan Mtr FLA (ea.)	1.6
Power Ex Mtr Qty	1
Powered Ex Voltage	460-1-60
Power Ex Mtr FLA (ea)	2.2
Combustion Mtr Qty	1
Combustion Motor Voltage	208/230-1-60
Combustion Mtr FLA (ea)	0.5



# York® Sun™ Pro 3-12.5 Ton Package

Single Package R-410A Air Conditioner

Project Name: 3507 - Port Neches, TX

Unit Model #: ZT120N18R4B5GCL2R1

Quantity: 1 Tag #: RTU-2

System: ZT120N18R4B5GCL2R1

## Factory Installed Options

### ZT120N18R4B5GCL2R1

Equipment Options	Option(s) Selected
Product Category:	<b>ZT</b> Single Packaged R-410A Ultra High Efficiency Air Conditioner 13.1 EER
Nominal Cooling Capacity:	<b>120</b> 10 Ton Three Stage Cooling
Heat Type and Nominal Heat Capacity:	<b>N18</b> 180 MBH Input Aluminized Steel, Two Stage Gas Heat
Blower Option:	<b>R</b> VFD Standard 3 HP High Static Belt Drive Blower IntelliSpeed control of the VFD based on stages of cooling (Provides Single Zone VAV Fan Operation as defined by ASHRAE 90.1 section 6.4.3.10)
Voltage:	<b>4</b> 460-3-60
Outside Air Option:	<b>B</b> Dry Bulb Low Leak Economizer w/Barometric Relief and Hoods (Bottom or Horizontal End Return Only) with Economizer Fault Detection & Diagnostic (Meets ASHRAE 90.1-2013, IECC 2015, California Title 24, AMCA 511).
Service Options:	<b>5</b> Non-Powered Convenience Outlet HACR Circuit Breaker/Disconnect
Sensor Options:	<b>G</b> Supply Air Smoke Detector
Controls:	<b>C</b> Smart Equipment Controller including Discharge Air, Return Air, and Outdoor Air Temperature Sensors. BACNet MS/TP, Modbus and N2 Communication Card.
Refrigeration:	<b>L</b> E-Coat Condenser Coil Micro-Channel "all-aluminum" condenser coil, Copper tube/aluminum fin evaporator coil MagnaDry Reheat
Additional Options:	<b>2</b> 2" Pleated Filters (MERV 8) Phase Monitor
Cabinet Options:	<b>R</b> Composite Drain Pan - Back Connection
Product Generation:	<b>1</b>

## Field Installed Accessories

1BD0408 - Burglar Bars (32.0 lbs)

1CV0403 - Concentric Diffuser, Flush Mount, 20RD

1CV0404 - Concentric Diffuser, Flush Mount, 18X28



# York® Sun™ Pro 3-12.5 Ton Package

## Single Package R-410A Air Conditioner

Project Name: 3507 - Port Neches, TX

Unit Model #: ZT120N18R4B5GCL2R1

Quantity: 1 Tag #: RTU-2

System: ZT120N18R4B5GCL2R1

- 1CV0405 - Concentric Diffuser, Flush Mount, 18X32
- 1CV0412 - Concentric Diffuser, Side Discharge, 20RD
- 1CV0413 - Concentric Diffuser, Side Discharge, 18X28
- 1CV0414 - Concentric Diffuser, Side Discharge, 18X32
- 1CV0420 - Concentric Diffuser, Specialty, 24X24
- 1CV0426 - Concentric Diffuser, Specialty, 24X24
- 1FE0412 - Flue Exhaust Extension Kit (14.0 lbs)
- 1FF0414 - 2" Only Metal Filter Frame Kit (16.0 lbs)
- 1GP0405 - Gas Piping Kit for Bottom Gas Supply Connection with External Shut-Off (includes: Internal gas pipe, fittings, gas cock & panel gaskets) (10.0 lbs)
- 1HA0442 - High Altitude Kit for Natural Gas - For applications between 2000 and 6000 feet altitude (1.0 lbs)
- 1HA0443 - High Altitude Kit for Propane - For applications between 2000 and 6000 feet altitude (1.0 lbs)
- 1HG0434 - Hail Guard Kit-Provent Style (30.0 lbs)
- 1HG0441 - Hail Guard Kit-Diamond Pattern (44.0 lbs)
- 1NP0459 - Natural Gas to Propane Conversion Kit (2-Stage) (2.0 lbs)
- 1RC0470 - Roof Curb - 8" High, Flat, Uninsulated, Full Perimeter (Shipped Knocked Down) (135.0 lbs)
- 1RC0471 - Roof Curb - 14" High, Flat, Uninsulated, Full Perimeter (Shipped Knocked Down) (135.0 lbs)
- 1RC0472 - Roof Curb, Transition-Sunline 7.5T thru 12.5T to Pro 3.0T thru 12.5T (Shipped Assembled) (200.0 lbs)
- 1RC0476 - Roof Curb - 24" High, Flat, Uninsulated, Full Perimeter (Shipped Knocked Down) (135.0 lbs)
- 1WC0412 - Wooden Crate (445.0 lbs)
- 2AP0402 - Air Proving Switch (1.0 lbs)
- 2AQ04700524 - CO<sup>2</sup> Space Sensor - Wall Mount Accessory (5.0 lbs)
- 2AQ04700624 - CO<sup>2</sup> Unit Mount Accessory (4.6 lbs)
- 2EC0401 - Kit, Single Enthalpy Field Installed (1.0 lbs)
- 2EC0402 - Kit, Dual Enthalpy Field Installed (Includes two humidity sensors) (1.0 lbs)
- 2ET077001124 - Honeywell T7350, 2 Heat / 4 Cool, Auto/Man Changeover, Electronic 7 Day Programmable (2.0 lbs)
- 2PE04704746 - Power Exhaust 460V without Baro Relief Downflow or Horizontal (19.0 lbs)
- 2SD04700924 - Smoke Detector Kit w/ Mounting Hardware for Return Air (Downflow Only) Only (10.0 lbs)
- S1-02815208000 - Blower Sheave for 8.5 and 10 Ton High Static Field Installed Drive (2.8 lbs)
- S1-03102529000 - Non-Networking Wall Sensor – Allows remote sensing and control from single or multiple zones. (0.2 lbs)
- S1-03102529004 - Non-Networking Wall Sensor with Over-ride button – Allows remote sensing and control from single or multiple zones. Override allows setpoint to be overridden for 2 hour time period. (0.2 lbs)
- S1-03102529006 - Non-Networking Wall Sensor with Setpoint Adjustment and Over-ride Button – Allows remote sensing and control from single or multiple zones. Allows setpoint to be adjusted  $\pm 5^\circ$  F. Override allows setpoint to be overridden for 2 hour time period. (0.2 lbs)
- S1-ADDWIRE - Add-a-Wire allows 5-wire thermostats to use only 4 wires. (0.3 lbs)
- S1-CTS DTS - CTS Wired Temperature Sensor for thermostat | Duct \*Also works for LX Series (0.3 lbs)
- S1-CTS HTS - CTS Hardwired Temperature Sensor for CTS Thermostats \*Works with LX series as well (0.2 lbs)
- S1-CTS PLATE - Wall Plate for CTS Thermostats \*Also works for new platform LX series models below (0.0 lbs)
- S1-CTS WFTS - CTS Temperature Sensor with WiFi for CTS Thermostats \*Also works with LX Series (0.1 lbs)
- S1-LX LOCK - Locking Ring For LX-Series Thermostats (0.4 lbs)
- S1-LX PLATE - Wall Plate For LX-Series Thermostats (0.0 lbs)
- S1-LX WFM - For LX Series Thermostats - WiFi Communication (1.0 lbs)
- S1-MP-PRTKIT-0P - MAP (Multiple Access Portal) Gateway Kit- Replacement MAP gateway protective case, lanyard and communication cable. Use only to replace worn or damaged components. (0.3 lbs)
- S1-NSB8BHN041-0 - Wall Temperature and 3% Relative Humidity Combined Sensor, No Display, WHITE, NO JCI LOGO, NS8000 Series (0.4 lbs)
- S1-NSB8BHN043-0 - Wall Temperature and 3% Relative Humidity Combined Sensor, No Display, BLACK, NO JCI LOGO, NS8000 Series (0.4 lbs)
- S1-NSB8BHN141-0 - Wall Temperature and 3% Relative Humidity Combined Sensor, Warmer/Cooler Display, WHITE, NO JCI LOGO, NS8000 Series (0.4 lbs)
- S1-NSB8BHN143-0 - Wall Temperature and 3% Relative Humidity Combined Sensor, Warmer/Cooler Display, BLACK, NO JCI LOGO, NS8000 Series (0.4 lbs)
- S1-NSB8BHN240-0 - Wall Temperature and 3% Relative Humidity Combined Sensor, Full Display, WHITE, JCI LOGO, NS8000 Series (0.4 lbs)
- S1-NSB8BHN241-0 - Wall Temperature and 3% Relative Humidity Combined Sensor, Full Display, WHITE, NO JCI LOGO, NS8000 Series (0.4 lbs)



# York® Sun™ Pro 3-12.5 Ton Package

## Single Package R-410A Air Conditioner

Project Name: **3507 - Port Neches, TX**

Unit Model #: **ZT120N18R4B5GCL2R1**

Quantity: **1** Tag #: **RTU-2**

System: **ZT120N18R4B5GCL2R1**

- S1-NSB8BHN243-0 - Wall Temperature and 3% Relative Humidity Combined Sensor, Full Display, BLACK, NO JCI LOGO, NS8000 Series (0.4 lbs)
- S1-NSB8BPN240-0 - Wall Temperature and 2% Relative Humidity Combined Sensor, Full Display, WHITE, JCI LOGO, NS8000 Series (0.4 lbs)
- S1-NSB8BPN241-0 - Wall Temperature and 2% Relative Humidity Combined Sensor, Full Display, WHITE, NO JCI LOGO, NS8000 Series (0.4 lbs)
- S1-NSB8BPN243-0 - Wall Temperature and 2% Relative Humidity Combined Sensor, Full Display, BLACK, NO JCI LOGO, NS8000 Series (0.4 lbs)
- S1-NSB8BTN041-0 - Wall Temperature Sensor, No Display, WHITE, NO JCI LOGO, NS8000 Series (0.4 lbs)
- S1-NSB8BTN043-0 - Wall Temperature Sensor, No Display, BLACK, NO JCI LOGO, NS8000 Series (0.4 lbs)
- S1-NSB8BTN141-0 - Wall Temperature Sensor, Warmer/Cooler Display, WHITE, NO JCI LOGO, NS8000 Series (0.4 lbs)
- S1-NSB8BTN143-0 - Wall Temperature Sensor, Warmer/Cooler Display, BLACK, NO JCI LOGO, NS8000 Series (0.4 lbs)
- S1-NSB8BTN240-0 - Wall Temperature Sensor, Full Display, WHITE, JCI LOGO, NS8000 Series (0.4 lbs)
- S1-NSB8BTN241-0 - Wall Temperature Sensor, Full Display, WHITE, NO JCI LOGO, NS8000 Series (0.4 lbs)
- S1-NSB8BTN243-0 - Wall Temperature Sensor, Full Display, BLACK, NO JCI LOGO, NS8000 Series (0.4 lbs)
- S1-TEC3030-14-000 - 7 DAY PROGRAMMABLE THERMOSTAT, ZIGBEE PRO WIRELESS COMMUNICATION, RTU/HEAT PUMP WITH ECON, FULL COLOR, WHITE, JCI LOGO (0.8 lbs)
- S1-TEC3030-16-000 - 7 DAY PROGRAMMABLE THERMOSTAT, ZIGBEE PRO WIRELESS COMMUNICATION, RTU/HEAT PUMP WITH ECON, AND FULL COLOR, WHITE, NO LOGO (0.8 lbs)
- S1-TEC3031-14-000 - 7 DAY PROGRAMMABLE THERMOSTAT, ZIGBEE PRO WIRELESS COMMUNICATION, RTU/HEAT PUMP WITH ECON, OCC SENSOR, FULL COLOR, WHITE, JCI LOGO (0.8 lbs)
- S1-TEC3031-16-000 - 7 DAY PROGRAMMABLE THERMOSTAT, ZIGBEE PRO WIRELESS COMMUNICATION, RTU/HEAT PUMP WITH ECON, OCC SENSOR, FULL COLOR, WHITE, NO LOGO (0.8 lbs)
- S1-TEC3630-14-000 - 7 DAY PROGRAMMABLE THERMOSTAT, OPTIONAL MSTP OR N2 COMMUNICATION, RTU/HEAT PUMP WITH ECON, FULL COLOR, WHITE, JCI LOGO (0.8 lbs)
- S1-TEC3631-14-000 - 7 DAY PROGRAMMABLE THERMOSTAT, OPTIONAL MSTP OR N2 COMMUNICATION, RTU/HEAT PUMP WITH ECON, OCC SENSOR, FULL COLOR, WHITE, JCI LOGO (0.8 lbs)
- S1-TEC3631-16-000 - 7 DAY PROGRAMMABLE THERMOSTAT, OPTIONAL MSTP OR N2 COMMUNICATION, RTU/HEAT PUMP WITH ECON, OCC SENSOR, FULL COLOR, WHITE, NO LOGO (0.8 lbs)
- S1-YK-MAP1810-0P - MAP (Multiple Access Portal) Gateway- For use with SimplicitySE Control. (0.2 lbs)
- S1-YK-MAP1810-0S - Stationary MAP Gateway (Includes MAP Gateway, Field Bus Adapter, Mounting Bracket and 100 to 240 VAC Power Supply). US-compatible counties. (1.9 lbs)

Project Name: 3507 - Port Neches, TX

Unit Model #: ZT120N18R4B5GCL2R1

Quantity: 1 Tag #: RTU-2

### Consolidated Drawing

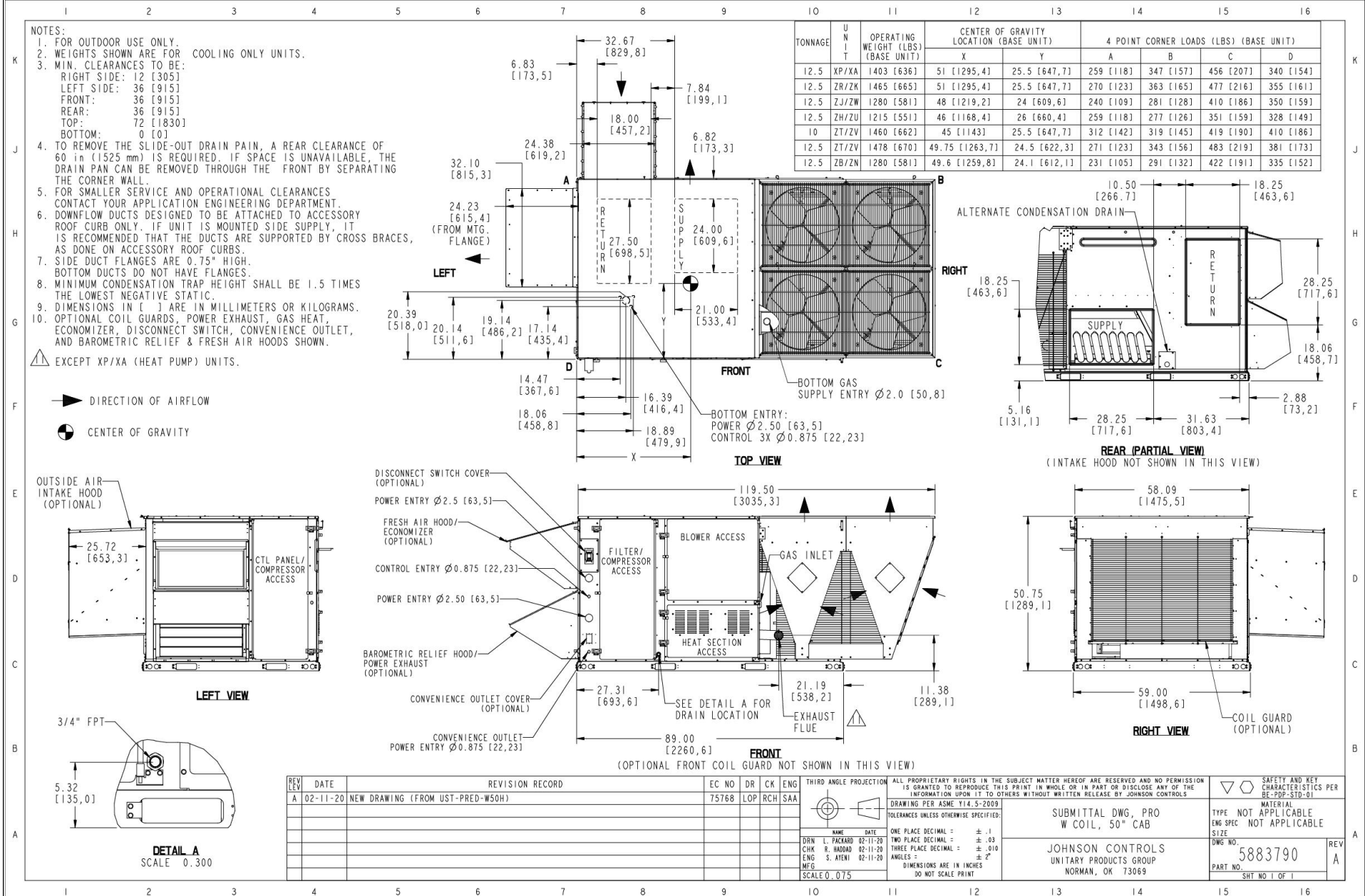

### Low Leak Downflow Economizer

### Low Leak Downflow Economizer (shown with optional Power Exhaust)

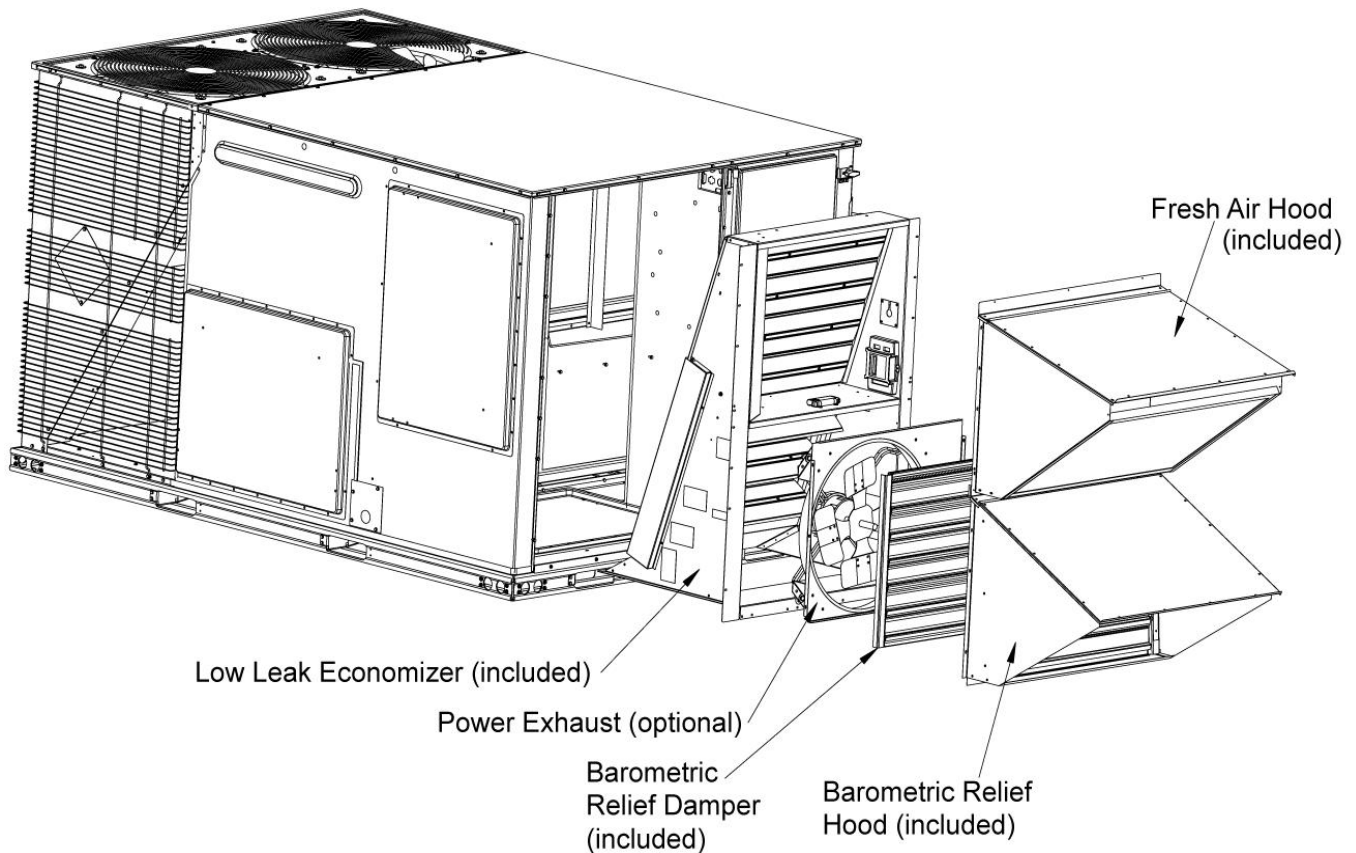

Low leak economizers are capable achieving low leakage rates of 3 cfm/sq. ft at 1" of static pressure, meeting or exceeding the following standards:

- ASHRAE 90.1-2010
- ASHRAE 62
- AMCA 511 (licensed as Class 1A damper)
- International Energy Conservation Code (IECC)
- California Title 24

The outdoor intake opening shall be covered with a rain hood that matches the exterior of the unit. Water eliminator/filters shall be provided.

Simultaneous economizer/compressor operation is also possible. Dampers shall fully close on power loss.

## Single Package R-410A Air Conditioner

Project Name: 3507 - Port Neches, TX

Unit Model #: ZT120N18R4B5GCL2R1

Quantity: 1 Tag #: RTU-2

### Seismic Certification



OFFICE OF STATEWIDE HEALTH PLANNING AND DEVELOPMENT  
FACILITIES DEVELOPMENT DIVISION

### APPLICATION FOR OSHPD SPECIAL SEISMIC CERTIFICATION PREAPPROVAL (OSP)

OFFICE USE ONLY

APPLICATION #: OSP - 0213

### OSHPD Special Seismic Certification Preapproval (OSP)

Type:  New  Renewal

### Manufacturer Information

Manufacturer: Johnson Controls Inc. (JCI)

Manufacturer's Technical Representative: Cameron Boyce, Engineer II

Mailing Address: 5005 Interstate Drive, Norman, OK, 73069

Telephone: (405) 419-6830

Email: [cameron.w.boyce@jci.com](mailto:cameron.w.boyce@jci.com)

### Product Information

Product Name: Predator Rooftop Air Conditioning Units

Product Type: Packaged Air Conditioning Units OSP-0213

Product Model Number: See attached

(List all unique product identification numbers and/or part numbers)

The units are enclosures with the following subcomponents: refrigerant compressors, outdoor fan motors, indoor coils, outdoor coils, reversing valve with coil, thermostatic expansion valves, standard indoor blower motor, Variable frequency drive indoor blower motor, exhaust fan motor, variable frequency drive, economizer, electric heater, heat cells, filters, and other miscellaneous items included in the subcomponent tables.

Mounting Description: Units are rigid curb and isolated curb base mounted

### Applicant Information

Applicant Company Name: The VMC Group

Contact Person: John Giuliano

Mailing Address: 113 Main Street, Bloomingdale, NJ 07403

Telephone: (973) 838-1780

Email: [john.giuliano@thevmcgroup.com](mailto:john.giuliano@thevmcgroup.com)

I hereby agree to reimburse the Office of Statewide Health Planning and Development review fees in accordance with the California Administrative Code, 2016.

Signature of Applicant: 

Date: 8/28/19

Title: President

Company Name: The VMC Group

"Access to Safe, Quality Healthcare Environments that Meet California's Diverse

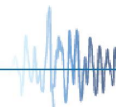
STATE OF CALIFORNIA - HEALTH AND HUMAN SERVICES AGENCY  
OSH-FD-759 (REV 12/16/15)

Page 1 of 3

## Single Package R-410A Air Conditioner

Project Name: 3507 - Port Neches, TX

Unit Model #: ZT120N18R4B5GCL2R1

Quantity: 1 Tag #: RTU-2

### Seismic Certification



#### OFFICE OF STATEWIDE HEALTH PLANNING AND DEVELOPMENT FACILITIES DEVELOPMENT DIVISION

#### California Licensed Structural Engineer Responsible for the Engineering and Test Report(s)

Company Name: The VMC GroupName: Kenneth TarlowCalifornia License Number: SE-2851Mailing Address: 113 Main Street, Bloomingdale, NJ 07403Telephone: (973) 838-1780Email: [ken.tarlow@thevmcgroup.com](mailto:ken.tarlow@thevmcgroup.com)

#### Supports and Attachments Preapproval

- Supports and attachments are preapproved under OPM- \_\_\_\_\_  
(Separate application for OSHPD Preapproval of Manufacturer's Certification (OPM) of Supports and attachments is required)
- Supports and attachments are not preapproved

#### Certification Method

- Testing in accordance with:  ICC-ES AC156
- Other (Please Specify): \_\_\_\_\_

#### Testing Laboratory

Company Name: DCL LabsContact Name: Josh Sailer, Laboratory ManagerMailing Address: 1315 Greg Street, Suite 109, Sparks, NV 89431Telephone: (775) 358-5085Email: [josh@shaketest.com](mailto:josh@shaketest.com)

"Access to Safe, Quality Healthcare Environments that Meet California's Diverse

STATE OF CALIFORNIA – HEALTH AND HUMAN SERVICES AGENCY  
OSH-FD-759 (REV 12/16/15)



Page 2 of 3

## Single Package R-410A Air Conditioner

Project Name: 3507 - Port Neches, TX

Unit Model #: ZT120N18R4B5GCL2R1

Quantity: 1 Tag #: RTU-2

### Seismic Certification



## OFFICE OF STATEWIDE HEALTH PLANNING AND DEVELOPMENT FACILITIES DEVELOPMENT DIVISION

### Seismic Parameters

Design in accordance with ASCE 7-16 Chapter 13:  Yes  NoDesign Basis of Equipment or Components ( $F_p/W_p$ ) = Rigid Curb = 1.5; Spring Isolated Curb = 4.5 $S_{DS}$  (Design spectral response acceleration at short period, g) = 2.00 $a_p$  (In-structure equipment or component amplification factor) = 2.5 $R_p$  (Equipment or component response modification factor) = Rigid Curb = 6.0; Spring Isolated Curb = 2.0 $\Omega_0$  (System overstrength factor) = 2.0 $I_p$  (Importance factor) = 1.5 $z/h$  (Height factor ratio) = 1

Equipment or Component Natural Frequencies (Hz) = See attachment

Overall dimensions and weight (or range thereof) = See attachment

Equipment or Components @ grade designed in accordance with ASCE 7-16 Chapter 15:  Yes  NoDesign Basis of Equipment or Components ( $V/W$ ) = $S_{DS}$  (Design spectral response acceleration at short period, g) = $S_{D1}$  (Design spectral response acceleration at 1 second period, g) = $R$  (Response modification coefficient) = $\Omega_0$  (System overstrength factor) = $C_d$  (Deflection amplification factor) = $I_p$  (Importance factor) = 1.5

Height to Center of Gravity above base =

Equipment or Component Natural Frequencies (Hz) =

Overall dimensions and weight (or range thereof) =

Tank(s) designed in accordance with ASME BPVC, 2015:  Yes  No

### List of Attachments Supporting Special Seismic Certification

 Test Report(s)  Drawings  Calculations  Manufacturer's Catalog Other(s) (Please Specify):

### OSHPD Approval (For Office Use Only) – Approval Expires on December 31, 2025

Signature:  Date: March 8, 2021

Print Name: Timothy J. Piland Title: SSE

Special Seismic Certification Valid Up to:  $S_{DS}$  (g) = 2.00  $z/h$  = 1

Condition of Approval (if applicable):

"Access to Safe, Quality Healthcare Environments that Meet California's Diverse

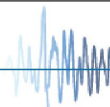
STATE OF CALIFORNIA – HEALTH AND HUMAN SERVICES AGENCY  
OSH-FD-759 (REV 12/16/15)

Page 3 of 3

## Single Package R-410A Air Conditioner

Project Name: **3507 - Port Neches, TX**

Unit Model #: **ZT120N18R4B5GCL2R1**

Quantity: **1** Tag #: **RTU-2**

### Seismic Certification

**Table 1 - Certified Components**

Manufacturer: Johnson Controls and other Unitary Product Group brands (York, Coleman, Luxaire, Evcon, Fraser-Johnston and Ready Ship)

Product Line: JCI Packaged Rooftop Units

Product Construction: Cabinets constructed of G90 galvanized 1,000 hour salt spray (per ASTM-B117) rated powder-coated 20 gage carbon steel wrapper and duct panel with integral corner posts, all attached at the base to four (4) full perimeter 14 gage base rails with #10 sheet metal screws.

Options: 230-575 V, economizer, power exhaust, electric or gas heater, variable frequency drive

Mounting Description: Rigid or Flexible Curb Mounting

Product Line	Model Number <sup>2</sup>	Dimensions (inches)			Operating Weight (lb)	Nominal Cooling Capacity (Tons)	Sds (g), z/h=1	Unit
		Depth	Width	Height				
Predator Air Handling Units (Short)	ZH/ZU/JA3 037	89	59	42	860 <sup>1</sup>	3	2.0	3
	ZJ/ZW/JA3 037	89	59	42	740	3		Interpolated
	ZR/ZK/JA3 037	89	59	42	980 <sup>1</sup>	3		1
	ZT/ZV/JA3 037	89	59	42	922	3		Interpolated
	ZH/ZU/JA4 049	89	59	42	763	4		Interpolated
	ZJ/ZW/JA4 049	89	59	42	762	4		Interpolated
	ZR/ZK/JA4 049	89	59	42	880	4		Interpolated
	ZT/ZV/JA4 049	89	59	42	960	4		Interpolated
	ZH/ZU/JA5 061	89	59	42	772	5		Interpolated
	ZJ/ZW/JA5 061	89	59	42	1,070 <sup>1</sup>	5		4
	ZR/ZK/JA5 061	89	59	42	1,070 <sup>1</sup>	5		2
	ZT/ZV/JA5 061	89	59	42	968	5		Extrapolated
Predator Air Handling Units (Standard)	XP/XA/J06 078	89	59	42	970 <sup>1</sup>	6.5	2.0	7
	ZF/ZS/J06 078	89	59	42	1,090 <sup>1</sup>	6.5		10
	ZH/ZU/J06 078	89	59	42	910	6.5		Interpolated
	ZJ/ZW/J06 078	89	59	51	1030	6.5		Interpolated
	ZR/ZK/J06 078	89	59	51	1,060 <sup>1</sup>	6.5		5
	ZF/ZS/J07 090	89	59	42	860	7.5		Interpolated
	ZH/ZU/J07 090	89	59	42	910	7.5		Interpolated
	ZJ/ZW/J07 090	89	59	51	1,081	7.5		Interpolated
	XP/XA/J07 090	89	59	42	920	7.5		Interpolated
	ZR/ZK/J07 090	89	59	42	965	7.5		Interpolated
	ZF/ZS/J08 102	89	59	51	1,020	8.5		Interpolated
	ZH/ZU/J08 102	89	59	51	1,030	8.5		Interpolated
	ZJ/ZW/J08 102	89	59	51	1,060	8.5		Interpolated
	XP/XA/J08 102	89	59	51	1,135	8.5		Interpolated
	ZR/ZK/J08 102	89	59	51	1,200	8.5		Interpolated
	ZF/ZS/J10 120	89	59	51	1,060	10		Interpolated
	ZH/ZU/J10 120	89	59	51	1,090	10		Interpolated
	ZJ/ZW/J10 120	89	59	51	1,070	10		Interpolated
	XP/XA/J10 120	89	59	51	1,135	10		Interpolated
	ZR/ZK/J10 120	89	59	51	1,200	10		Interpolated
	ZF/ZS/J12 150	119.5	59	51	1,253	12.5		Interpolated
	ZH/ZU/J12 150	119.5	59	51	1,250 <sup>1</sup>	12.5		11
	XP/XA/J12 150	119.5	59	51	1,510 <sup>1</sup>	12.5		8
	ZJ/ZW/J12 150	119.5	59	51	1,570 <sup>1</sup>	12.5		9
ZR/ZK/J12 150	119.5	59	51	1,600 <sup>1</sup>	12.5	6		
Predator Air Handling Units (Ultra High Efficiency)	ZT/ZV 120	119.5	59	51	1,470 <sup>1</sup>	10	2.0	12
	ZT/ZV 078	119.5	59	51	1,550	6.5		Interpolated
	ZT/ZV 090	119.5	59	51	1,550	7.5		Interpolated
	ZT/ZV 102	119.5	59	51	1,575	8.5		Interpolated
	ZT/ZV 150	119.5	59	51	1,680 <sup>1</sup>	12.5		13

1. Weights listed for tested units are actual, not approximate weights. The weights listed for interpolated units are maximum weights, assuming all optional features are included. Optional features are summarized in the table below.

2. Model numbers are generalized for each type of unit and the associated BTU tonnage that the unit can output.

Unit Accessory	Operating Weight (lbs.)
Economizer	85
Power Exhaust	35
Electric Heat	49
Gas Heat	110
Variable Frequency Drive	30

1. Weight given is for the maximum electric heater size available.

2. Weight given for the gas heater is for the maximum number of tube heat exchangers available (8 tube).

3. Weight includes mounting hardware, controls and manual bypass option.

## Single Package R-410A Air Conditioner

 Project Name: **3507 - Port Neches, TX**

 Unit Model #: **ZJ061N08D4B5GCB2R3**

 Quantity: **1** Tag #: **RTU-3**

 System: **ZJ061N08D4B5GCB2R3**

### Cooling Performance

Total gross capacity	59.1 MBH
Sensible gross capacity	39.7 MBH
Total net capacity	55.6 MBH
Sensible net capacity	36.2 MBH
Seasonal Efficiency (at ARI)	14.50 SEER
Efficiency (at ARI)	12.20 EER
Ambient DB temp.	95.0 °F
Entering DB temp.	76.2 °F
Entering WB temp.	63.2 °F
Leaving DB temp.	53.6 °F
Leaving WB temp.	50.4 °F
Leaving air temp dew point	47.80 °F
Power input (w/o blower)	4.00 kW
Sound power	77 dB(A)

### Refrigerant

Refrigerant type	R-410A
Sys1	7 lbs 8 oz

### Gas Heating Performance

Entering DB temp.	60 °F
Heating output capacity (Max)	65 MBH
Supply air	1625 CFM
Heating input capacity (Max)	80 MBH
Leaving DB temp.	97.0 °F
Air temp. rise	37.0 °F
SSE	81.0 %
Stages	2

### Supply Air Blower Performance

Supply air	1625 CFM
Ext. static pressure	1.3 IWG
Addl. Unit Losses (Options/Accessories)	0.14 IWG
Blower speed	1051 RPM
Max BHP of Motor (including service factor)	2.30 HP
Duct location	Bottom
Motor rating	2.00 HP
Actual required BHP	1.09 HP
Power input	1.02 kW
Elevation	0 ft.
Drive type	BELT

### Outside/Mixed Air

Outside Air Cfm	100 CFM
Outside Air DB temp.	95 °F
Outsided Air WB temp.	78 °F
Outside Air RH	47.3 %
Return Air CFM	1525 CFM
Return Air DB temp.	75 °F
Return Air WB temp.	62 °F
Return Air RH	48.1 %

### Electrical Data

Power supply	460-3-60
Unit min circuit ampacity	13.1 Amps
Unit max over-current protection	15 Amps

### Dimensions & Weight

Hgt	42 in.	Len	89 in.	Wth	59 in.
Weight with factory installed options	955 lbs.				

### Clearances

Right	12 in.	Front	36 in.	Rear	36 in.
Top	72 in.	Bottom	0 in.	Left	36 in.

Note: Please refer to the tech guide for listed maximum static pressures



### 5 Ton

- York Sun Pro units are manufactured at an ISO 9001 registered facility and each rooftop is completely computer-run tested prior to shipment.

### Unit Features

- Single Stage Cooling
- 80 MBH Input Aluminized Steel, Two Stage Gas Heat
- Unit Cabinet Constructed of Powder Painted Steel, Certified At 750 Hours Salt Spray Test (ASTM B-117 Standards)
- Full perimeter base rails with built in rigging capabilities
- Dry Bulb Low Leak Economizer w/Barometric Relief and Hoods (Bottom or Horizontal End Return Only) with Economizer Fault Detection & Diagnostic (Meets ASHRAE 90.1-2013, IECC 2015, California Title 24, AMCA 511).
- 2 HP High Static Belt Drive Blower
- Unit Ships with 2" Pleated Filters (MERV 8)
- Solid Core Liquid Line Filter Driers
- Replacement Filters: 4 - (24" x 16"). Unit accepts 2" or 4" wide filters.
- Non-Powered Convenience Outlet
- Through-the-Curb and Through-the-Base Utility Connections
- Single Point Power Connection
- HACR Circuit Breaker/Disconnect
- Short Circuit Current: 5kA RMS Symmetrical
- Supply Air Smoke Detector
- Micro-Channel "all-aluminum" condenser coil, Copper tube/aluminum fin evaporator coil
- E-Coat Condenser Coil
- Composite Drain Pan - Back Connection
- Tool-free maintenance with features like hinged doors for all-access panels, slide-out blower and blower motor tray

### Standard Unit Controller: Smart Equipment Control Board

- Safety Monitoring - Monitors the High and Low-Pressure Switches, the Freezestats, the Gas Valve, if Applicable, and the Temperature Limit Switch on Gas and Electric Heat Units. The Unit Control Board will Alarm on Ignition Failures, Safety Lockouts and Repeated Limit Switch Trips.

### Warranty

- One (1) Year Limited Warranty on the Complete Unit
- Three (3) Year Warranty - ElectroFin Condenser Coil
- Five (5) Year Warranty - Compressors and Electric Heater Elements
- Ten (10) Year Limited Warranty - Aluminized Steel Heat Exchanger





# York® Sun™ Pro 3-12.5 Ton Package

Single Package R-410A Air Conditioner

Project Name: 3507 - Port Neches, TX

Unit Model #: ZJ061N08D4B5GCB2R3

Quantity: 1 Tag #: RTU-3

System: ZJ061N08D4B5GCB2R3

### Additional Electrical Data

Power supply	460-3-60
Unit min circuit ampacity	13.1 Amps
Unit max over-current protection	15 Amps
Min Voltage	432 V
Max Voltage	504 V
Comp #1 RLA	6.0
Comp #1 LRA	60.0
Indoor Mtr Voltage	460-3-60
Indoor Mtr FLA	3.4
Outdoor Mtr Qty	2
Outdoor Fan Voltage	460-1-60
OD Fan Mtr FLA (ea.)	1.1
Power Ex Mtr Qty	1
Powered Ex Voltage	460-1-60
Power Ex Mtr FLA (ea)	2.2



# York® Sun™ Pro 3-12.5 Ton Package

Single Package R-410A Air Conditioner

Project Name: 3507 - Port Neches, TX

Unit Model #: ZJ061N08D4B5GCB2R3

Quantity: 1 Tag #: RTU-3

System: ZJ061N08D4B5GCB2R3

## Factory Installed Options

### ZJ061N08D4B5GCB2R3

Equipment Options	Option(s) Selected
Product Category:	<b>ZJ</b> Single Packaged R-410A Air Conditioner, High Efficiency 14.5 SEER / 12.2 EER
Nominal Cooling Capacity:	<b>061</b> 5 Ton Single Stage Cooling
Heat Type and Nominal Heat Capacity:	<b>N08</b> 80 MBH Input Aluminized Steel, Two Stage Gas Heat
Blower Option:	<b>D</b> 2 HP High Static Belt Drive Blower
Voltage:	<b>4</b> 460-3-60
Outside Air Option:	<b>B</b> Dry Bulb Low Leak Economizer w/Barometric Relief and Hoods (Bottom or Horizontal End Return Only) with Economizer Fault Detection & Diagnostic (Meets ASHRAE 90.1-2013, IECC 2015, California Title 24, AMCA 511).
Service Options:	<b>5</b> Non-Powered Convenience Outlet HACR Circuit Breaker/Disconnect
Sensor Options:	<b>G</b> Supply Air Smoke Detector
Controls:	<b>C</b> Smart Equipment Controller including Discharge Air, Return Air, and Outdoor Air Temperature Sensors. BACNet MS/TP, Modbus and N2 Communication Card.
Refrigeration:	<b>B</b> E-Coat Condenser Coil Micro-Channel "all-aluminum" condenser coil, Copper tube/aluminum fin evaporator coil
Additional Options:	<b>2</b> 2" Pleated Filters (MERV 8) Phase Monitor
Cabinet Options:	<b>R</b> Composite Drain Pan - Back Connection
Product Generation:	<b>3</b>

## Field Installed Accessories

- |  |   |  |
|--|---|--|
| <input type="radio"/> 1BD0408 - Burglar Bars (32.0 lbs)                              | <input type="radio"/> 1FE0412 - Flue Exhaust Extension Kit (14.0 lbs)   | <input type="radio"/> 1HA0450 - High Altitude Kit for Natural Gas - For applications between 2000 and 6000 feet altitude (1.0 lbs) |
| <input type="radio"/> 1CG0428 - Coil Guard (20.0 lbs)                                | <input type="radio"/> 1FF0415 - 2" Only metal Filter Frame Kit (16.0 lbs)   | <input type="radio"/> 1HA0452 - High Altitude Kit for Propane - For applications between 2000 and 6000 feet altitude (1.0 lbs)     |
| <input type="radio"/> 1CV0402 - Concentric Diffuser, Flush Mount, 18RD               | <input type="radio"/> 1GP0405 - Gas Piping Kit for Bottom Gas Supply Connection with External Shut-Off (includes: Internal gas pipe, fittings, gas cock & panel gaskets) (10.0 lbs) |  |
| <input type="radio"/> 1CV0411 - Concentric Diffuser, Side Discharge, 18RD (55.0 lbs) |   |  |
| <input type="radio"/> 1CV0419 - Concentric Diffuser, Specialty, 18X18                |   |  |



# York® Sun™ Pro 3-12.5 Ton Package

## Single Package R-410A Air Conditioner

Project Name: 3507 - Port Neches, TX

Unit Model #: ZJ061N08D4B5GCB2R3

Quantity: 1 Tag #: RTU-3

System: ZJ061N08D4B5GCB2R3

- 1HG0415 - Hail Guard Kit-Diamond Pattern (50.0 lbs)
- 1HG0431 - Hail Guard Kit-Provent Style (20.0 lbs)
- 1LN0407 - Low NOx Kit
- 1NP0460 - Natural Gas to Propane Conversion Kit (2.0 lbs)
- 1RC0470 - Roof Curb - 8" High, Flat, Uninsulated, Full Perimeter (Shipped Knocked Down) (135.0 lbs)
- 1RC0471 - Roof Curb - 14" High, Flat, Uninsulated, Full Perimeter (Shipped Knocked Down) (135.0 lbs)
- 1RC0476 - Roof Curb - 24" High, Flat, Uninsulated, Full Perimeter (Shipped Knocked Down) (135.0 lbs)
- 1WC0412 - Wooden Crate (445.0 lbs)
- 2AP0402 - Air Proving Switch (1.0 lbs)
- 2AQ04700524 - CO<sup>2</sup> Space Sensor - Wall Mount Accessory (5.0 lbs)
- 2AQ04700624 - CO<sup>2</sup> Unit Mount Accessory (4.6 lbs)
- 2EC0401 - Kit, Single Enthalpy Field Installed (1.0 lbs)
- 2EC0402 - Kit, Dual Enthalpy Field Installed (Includes two humidity sensors) (1.0 lbs)
- 2LA04702412 - Low Ambient Kit - ICM 333 (2.2 lbs)
- 2PE04704746 - Power Exhaust 460V without Baro Relief Downflow or Horizontal (19.0 lbs)
- 2SD04700924 - Smoke Detector Kit w/ Mounting Hardware for Return Air (Downflow Only) Only (10.0 lbs)
- S1-02812496000 - Blower Sheave AK79 Field Installed Drive (4.0 lbs)
- S1-03102529000 - Non-Networking Wall Sensor – Allows remote sensing and control from single or multiple zones. (0.2 lbs)
- S1-03102529004 - Non-Networking Wall Sensor with Over-ride button – Allows remote sensing and control from single or multiple zones. Override allows setpoint to be overridden for 2 hour time period. (0.2 lbs)
- S1-03102529006 - Non-Networking Wall Sensor with Setpoint Adjustment and Over-ride Button – Allows remote sensing and control from single or multiple zones. Allows setpoint to be adjusted ± 5° F. Override allows setpoint to be overridden for 2 hour time period. (0.2 lbs)
- S1-ADDWIRE - Add-a-Wire allows 5-wire thermostats to use only 4 wires. (0.3 lbs)
- S1-CTS DTS - CTS Wired Temperature Sensor for thermostat | Duct \*Also works for LX Series (0.3 lbs)
- S1-CTS HTS - CTS Hardwired Temperature Sensor for CTS Thermostats \*Works with LX series as well (0.2 lbs)
- S1-CTS PLATE - Wall Plate for CTS Thermostats \*Also works for new platform LX series models below (0.0 lbs)
- S1-CTS WFTS - CTS Temperature Sensor with WiFi for CTS Thermostats \*Also works with LX Series (0.1 lbs)
- S1-LX LOCK - Locking Ring For LX-Series Thermostats (0.4 lbs)
- S1-LX PLATE - Wall Plate For LX-Series Thermostats (0.0 lbs)
- S1-LX WFM - For LX Series Thermostats - WiFi Communication (1.0 lbs)
- S1-MP-PRTKIT-0P - MAP (Multiple Access Portal) Gateway Kit- Replacement MAP gateway protective case, lanyard and communication cable. Use only to replace worn or damaged components. (0.3 lbs)
- S1-NSB8BHN041-0 - Wall Temperature and 3% Relative Humidity Combined Sensor, No Display, WHITE, NO JCI LOGO, NS8000 Series (0.4 lbs)
- S1-NSB8BHN043-0 - Wall Temperature and 3% Relative Humidity Combined Sensor, No Display, BLACK, NO JCI LOGO, NS8000 Series (0.4 lbs)
- S1-NSB8BHN141-0 - Wall Temperature and 3% Relative Humidity Combined Sensor, Warmer/Cooler Display, WHITE, NO JCI LOGO, NS8000 Series (0.4 lbs)
- S1-NSB8BHN143-0 - Wall Temperature and 3% Relative Humidity Combined Sensor, Warmer/Cooler Display, BLACK, NO JCI LOGO, NS8000 Series (0.4 lbs)
- S1-NSB8BHN240-0 - Wall Temperature and 3% Relative Humidity Combined Sensor, Full Display, WHITE, JCI LOGO, NS8000 Series (0.4 lbs)
- S1-NSB8BHN241-0 - Wall Temperature and 3% Relative Humidity Combined Sensor, Full Display, WHITE, NO JCI LOGO, NS8000 Series (0.4 lbs)
- S1-NSB8BHN243-0 - Wall Temperature and 3% Relative Humidity Combined Sensor, Full Display, BLACK, NO JCI LOGO, NS8000 Series (0.4 lbs)
- S1-NSB8BPN240-0 - Wall Temperature and 2% Relative Humidity Combined Sensor, Full Display, WHITE, JCI LOGO, NS8000 Series (0.4 lbs)
- S1-NSB8BPN241-0 - Wall Temperature and 2% Relative Humidity Combined Sensor, Full Display, WHITE, NO JCI LOGO, NS8000 Series (0.4 lbs)
- S1-NSB8BPN243-0 - Wall Temperature and 2% Relative Humidity Combined Sensor, Full Display, BLACK, NO JCI LOGO, NS8000 Series (0.4 lbs)
- S1-NSB8BTN041-0 - Wall Temperature Sensor, No Display, WHITE, NO JCI LOGO, NS8000 Series (0.4 lbs)
- S1-NSB8BTN043-0 - Wall Temperature Sensor, No Display, BLACK, NO JCI LOGO, NS8000 Series (0.4 lbs)
- S1-NSB8BTN141-0 - Wall Temperature Sensor, Warmer/Cooler Display, WHITE, NO JCI LOGO, NS8000 Series (0.4 lbs)
- S1-NSB8BTN143-0 - Wall Temperature Sensor, Warmer/Cooler Display, BLACK, NO JCI LOGO, NS8000 Series (0.4 lbs)
- S1-NSB8BTN240-0 - Wall Temperature Sensor, Full Display, WHITE, JCI LOGO, NS8000 Series (0.4 lbs)



# York® Sun™ Pro 3-12.5 Ton Package

## Single Package R-410A Air Conditioner

Project Name: 3507 - Port Neches, TX

Unit Model #: ZJ061N08D4B5GCB2R3

Quantity: 1 Tag #: RTU-3

System: ZJ061N08D4B5GCB2R3

- S1-NSB8BTN241-0 - Wall Temperature Sensor, Full Display, WHITE, NO JCI LOGO, NS8000 Series (0.4 lbs)
- S1-NSB8BTN243-0 - Wall Temperature Sensor, Full Display, BLACK, NO JCI LOGO, NS8000 Series (0.4 lbs)
- S1-TEC3030-14-000 - 7 DAY PROGRAMMABLE THERMOSTAT, ZIGBEE PRO WIRELESS COMMUNICATION, RTU/HEAT PUMP WITH ECON, FULL COLOR, WHITE, JCI LOGO (0.8 lbs)
- S1-TEC3030-16-000 - 7 DAY PROGRAMMABLE THERMOSTAT, ZIGBEE PRO WIRELESS COMMUNICATION, RTU/HEAT PUMP WITH ECON, AND FULL COLOR, WHITE, NO LOGO (0.8 lbs)
- S1-TEC3031-14-000 - 7 DAY PROGRAMMABLE THERMOSTAT, ZIGBEE PRO WIRELESS COMMUNICATION, RTU/HEAT PUMP WITH ECON, OCC SENSOR, FULL COLOR, WHITE, JCI LOGO (0.8 lbs)
- S1-TEC3031-16-000 - 7 DAY PROGRAMMABLE THERMOSTAT, ZIGBEE PRO WIRELESS COMMUNICATION, RTU/HEAT PUMP WITH ECON, OCC SENSOR, FULL COLOR, WHITE, NO LOGO (0.8 lbs)
- S1-TEC3630-14-000 - 7 DAY PROGRAMMABLE THERMOSTAT, OPTIONAL MSTP OR N2 COMMUNICATION, RTU/HEAT PUMP WITH ECON, FULL COLOR, WHITE, JCI LOGO (0.8 lbs)
- S1-TEC3630-16-000 - 7 DAY PROGRAMMABLE THERMOSTAT, OPTIONAL MSTP OR N2 COMMUNICATION, RTU/HEAT PUMP WITH ECON, FULL COLOR, WHITE, NO LOGO (0.8 lbs)
- S1-TEC3631-14-000 - 7 DAY PROGRAMMABLE THERMOSTAT, OPTIONAL MSTP OR N2 COMMUNICATION, RTU/HEAT PUMP WITH ECON, OCC SENSOR, FULL COLOR, WHITE, JCI LOGO (0.8 lbs)
- S1-TEC3631-16-000 - 7 DAY PROGRAMMABLE THERMOSTAT, OPTIONAL MSTP OR N2 COMMUNICATION, RTU/HEAT PUMP WITH ECON, OCC SENSOR, FULL COLOR, WHITE, NO LOGO (0.8 lbs)
- S1-YK-MAP1810-0P - MAP (Multiple Access Portal) Gateway- For use with SimplicitySE Control. (0.2 lbs)
- S1-YK-MAP1810-0S - Stationary MAP Gateway (Includes MAP Gateway, Field Bus Adapter, Mounting Bracket and 100 to 240 VAC Power Supply). US-compatible counties. (1.9 lbs)

Project Name: 3507 - Port Neches, TX

Unit Model #: ZJ061N08D4B5GCB2R3

Quantity: 1 Tag #: RTU-3

**Consolidated Drawing**

- NOTES:**
- FOR OUTDOOR USE ONLY.
  - WEIGHTS SHOWN ARE FOR COOLING ONLY UNITS.
  - MIN. CLEARANCES TO BE:  
 RIGHT SIDE: 12 [305]  
 LEFT SIDE: 36 [915]  
 FRONT: 36 [915]  
 REAR: 36 [915]  
 TOP: 72 [1830]  
 BOTTOM: 0 [0]
  - TO REMOVE THE SLIDE-OUT DRAIN PAN, A REAR CLEARANCE OF 60 in (1525 mm) IS REQUIRED. IF SPACE IS UNAVAILABLE, THE DRAIN PAN CAN BE REMOVED THROUGH THE FRONT BY SEPARATING THE CORNER WALL.
  - FOR SMALLER SERVICE AND OPERATIONAL CLEARANCES CONTACT YOUR APPLICATION ENGINEERING DEPARTMENT.
  - DOWNFLOW DUCTS DESIGNED TO BE ATTACHED TO ACCESSORY ROOF CURB ONLY. IF UNIT IS MOUNTED SIDE SUPPLY, IT IS RECOMMENDED THAT THE DUCTS ARE SUPPORTED BY CROSS BRACES, AS DONE ON ACCESSORY ROOF CURBS.
  - SIDE DUCT FLANGES ARE 0.75" HIGH. BOTTOM DUCTS DO NOT HAVE FLANGES.
  - MINIMUM CONDENSATION TRAP HEIGHT SHALL BE 1.5 TIMES THE LOWEST NEGATIVE STATIC.
  - DIMENSIONS IN [ ] ARE IN MILLIMETERS OR KILOGRAMS.
  - OPTIONAL COIL GUARDS, POWER EXHAUST, GAS HEAT, ECONOMIZER, DISCONNECT SWITCH, CONVENIENCE OUTLET, AND BAROMETRIC RELIEF & FRESH AIR HOODS SHOWN.
  - DELETED
  - 8 TUBE HEAT EXCHANGER IS NOT AVAILABLE FOR 3 & 4 TON UNITS.

TONNAGE	UNIT	OPERATING WEIGHT (LBS) (BASE UNIT)	CENTER OF GRAVITY LOCATION (BASE UNIT)		4 POINT CORNER LOADS (LBS) (BASE UNIT)			
			X	Y	A	B	C	D
6.5	ZF/ZS	860 [390]	38 [965,2]	24 [609,6]	200 [91]	149 [68]	218 [99]	292 [133]
7.5	ZF/ZS	880 [399]	38 [965,2]	24 [609,6]	205 [93]	153 [69]	223 [101]	299 [136]
5	ZH/ZU	864 [393]	40 [1016]	26 [660,4]	210 [95]	171 [78]	217 [99]	266 [121]
6.5 & 7.5	ZH/ZU	910 [413]	38 [965,2]	24 [609,6]	212 [96]	158 [72]	230 [104]	309 [140]
5	ZJ/ZW	770 [349]	40 [1016]	24 [609,6]	172 [78]	141 [64]	205 [93]	251 [114]
4	ZR/ZK	880 [399]	40 [1016]	26 [660,4]	214 [97]	174 [79]	221 [100]	271 [123]
5	ZR/ZK	868 [394]	40 [1016]	26 [660,4]	211 [96]	172 [78]	218 [99]	267 [121]
6.5	ZR/ZK	957 [435]	38 [965,2]	23 [584,2]	214 [97]	161 [73]	249 [113]	333 [151]
7.5	ZR/ZK	965 [438]	38 [965,2]	23 [584,2]	216 [98]	161 [73]	251 [114]	337 [153]
3	ZT/ZV	922 [418]	42.4 [1077]	24.7 [627,4]	202 [92]	184 [84]	255 [116]	281 [128]
4	ZT/ZV	960 [436]	42.5 [1079,5]	25.5 [647,7]	217 [98]	198 [90]	260 [118]	285 [129]
5	ZT/ZV	968 [439]	41.6 [1056,6]	25.5 [647,7]	223 [101]	196 [89]	257 [117]	293 [133]

- DIRECTION OF AIRFLOW
- CENTER OF GRAVITY

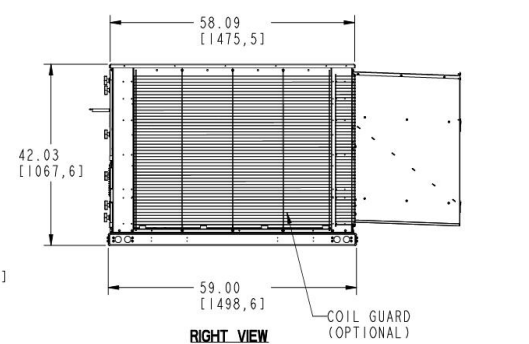
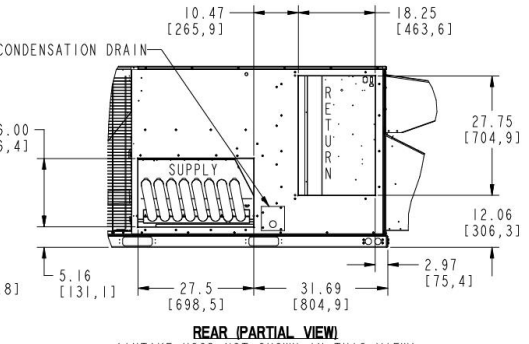
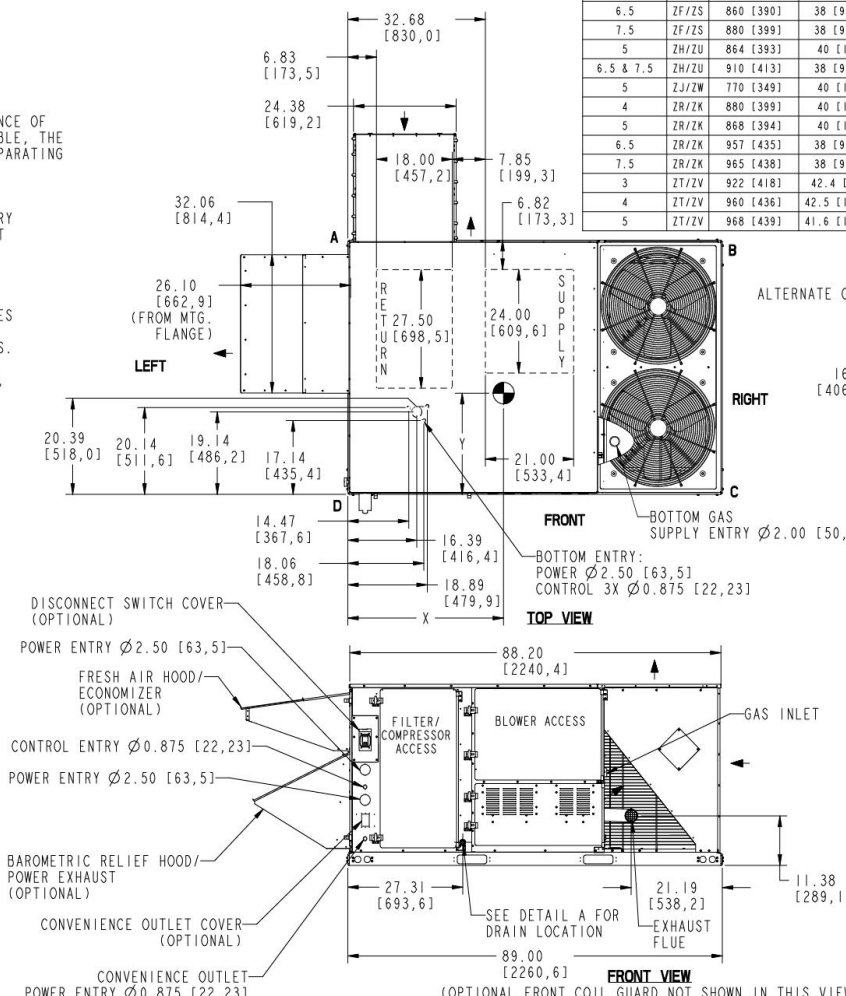
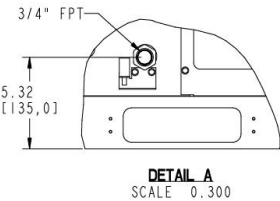
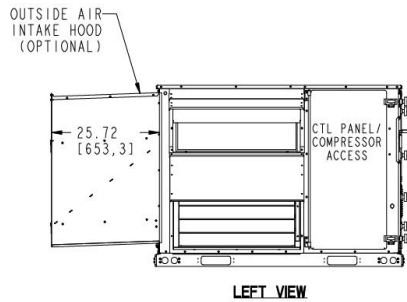

REV	DATE	REVISION RECORD	EC NO	DR	CK	ENG	THIRD ANGLE PROJECTION	ALL PROPRIETARY RIGHTS IN THE SUBJECT MATTER HEREOF ARE RESERVED AND NO PERMISSION IS GRANTED TO REPRODUCE THIS PRINT IN WHOLE OR IN PART OR DISCLOSE ANY OF THE INFORMATION UPON IT TO OTHERS WITHOUT WRITTEN RELEASE BY JOHNSON CONTROLS	SAFETY AND KEY CHARACTERISTICS PER BE-20P-STD-01
A	02-11-20	NEW DRAWING (FROM UST-PRED-20DF42H)	75768	LOP	RCH	SAA		DRAWING PER ASME Y14.5-2009	MATERIAL TYPE NOT APPLICABLE
TOLERANCES UNLESS OTHERWISE SPECIFIED: ONE PLACE DECIMAL = ± .1 TWO PLACE DECIMAL = ± .03 THREE PLACE DECIMAL = ± .010 ANGLES = ± 2° DIMENSIONS ARE IN INCHES DO NOT SCALE PRINT								SUBMITTAL DWG, PRO STD FLAT COIL, 2 ODF, 42" CAB JOHNSON CONTROLS UNITARY PRODUCTS GROUP NORMAN, OK 73069	ENG SPEC NOT APPLICABLE SIZE NOT APPLICABLE DWG NO. 5883783 PART NO. SHT NO. 1 OF 1

Project Name: 3507 - Port Neches, TX

Unit Model #: ZJ061N08D4B5GCB2R3

Quantity: 1 Tag #: RTU-3

### Component Locations

#### Component Location

##### Cooling With Gas Heat (3 Through 5 Ton)

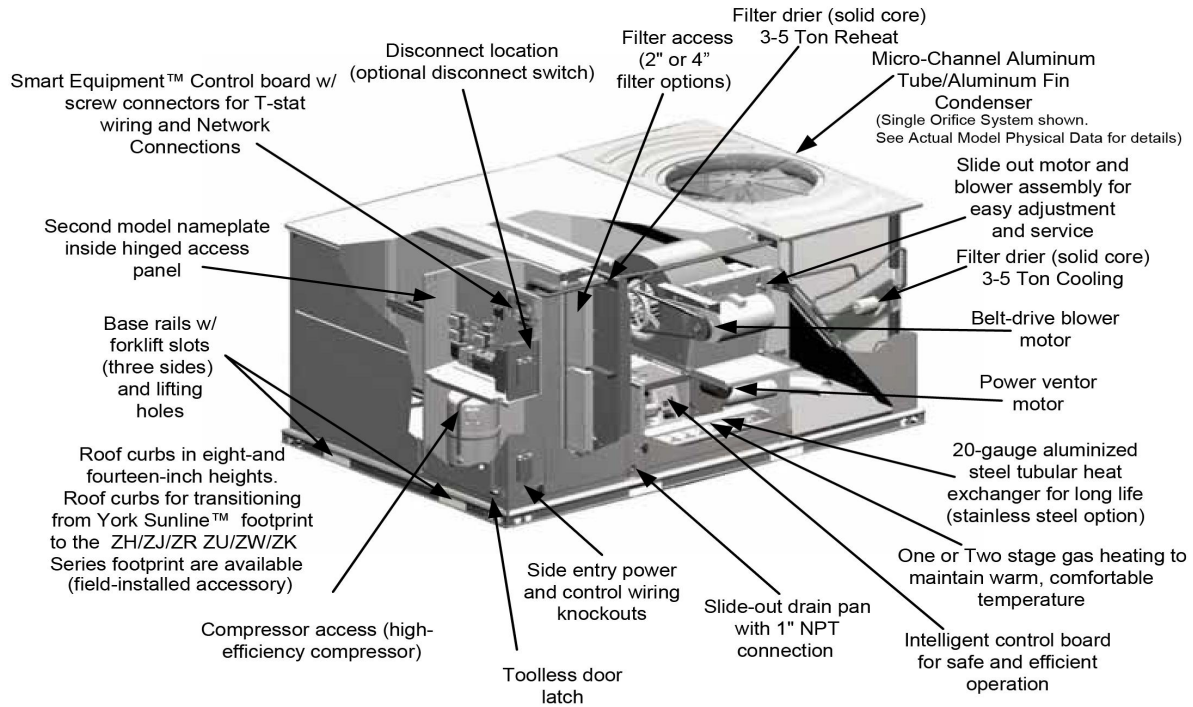

### Low Leak Downflow Economizer

### Low Leak Downflow Economizer (shown with optional Power Exhaust)

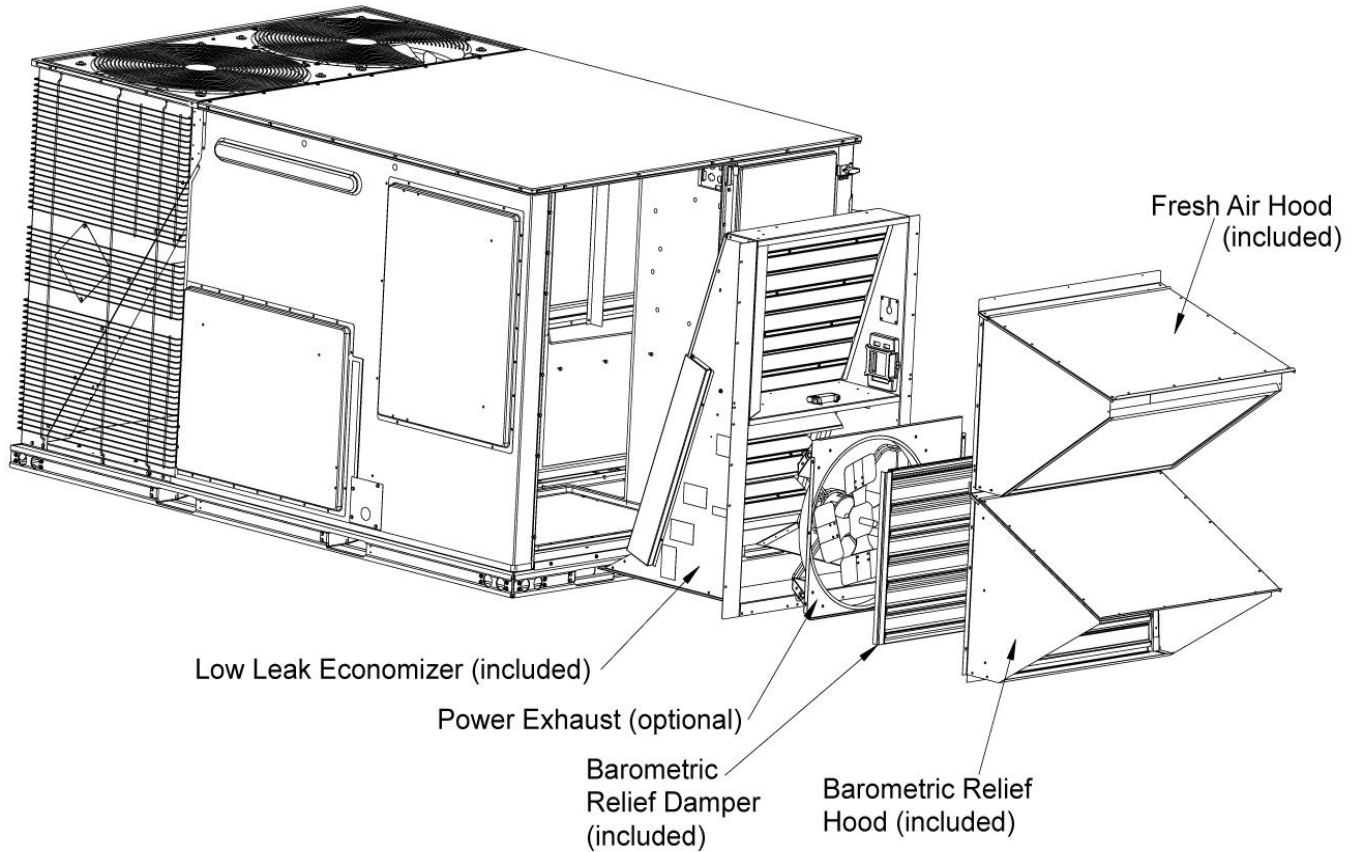

Low leak economizers are capable achieving low leakage rates of 3 cfm/sq. ft at 1" of static pressure, meeting or exceeding the following standards:

- ASHRAE 90.1-2010
- ASHRAE 62
- AMCA 511 (licensed as Class 1A damper)
- International Energy Conservation Code (IECC)
- California Title 24

The outdoor intake opening shall be covered with a rain hood that matches the exterior of the unit. Water eliminator/filters shall be provided.

Simultaneous economizer/compressor operation is also possible. Dampers shall fully close on power loss.

## Single Package R-410A Air Conditioner

Project Name: **3507 - Port Neches, TX**Unit Model #: **ZJ061N08D4B5GCB2R3**Quantity: **1** Tag #: **RTU-3**

### Seismic Certification



## OFFICE OF STATEWIDE HEALTH PLANNING AND DEVELOPMENT FACILITIES DEVELOPMENT DIVISION

### APPLICATION FOR OSHPD SPECIAL SEISMIC CERTIFICATION PREAPPROVAL (OSP)

OFFICE USE ONLY

APPLICATION #: **OSP - 0213**

### OSHPD Special Seismic Certification Preapproval (OSP)

Type:  New  Renewal

### Manufacturer Information

Manufacturer: Johnson Controls Inc. (JCI)Manufacturer's Technical Representative: Cameron Boyce, Engineer IIMailing Address: 5005 Interstate Drive, Norman, OK, 73069Telephone: (405) 419-6830 Email: cameron.w.boyce@jci.com

### Product Information

Product Name: Predator Rooftop Air Conditioning UnitsProduct Type: Packaged Air Conditioning Units **OSP-0213**Product Model Number: See attached

(List all unique product identification numbers and/or part numbers)

The units are enclosures with the following subcomponents: refrigerant compressors, outdoor fan motors, indoor coils, outdoor coils, reversing valve with coil, thermostatic expansion valves, standard indoor blower motor, Variable frequency drive indoor blower motor, exhaust fan motor, variable frequency drive, economizer, electric heater, heat cells, filters, and other miscellaneous items included in the subcomponent tables.

Mounting Description: Units are rigid curb and isolated curb base mounted

### Applicant Information

Applicant Company Name: The VMC GroupContact Person: John GiulianoMailing Address: 113 Main Street, Bloomingdale, NJ 07403Telephone: (973) 838-1780 Email: john.giuliano@thevmcgroup.com

I hereby agree to reimburse the Office of Statewide Health Planning and Development review fees in accordance with the California Administrative Code, 2016.

Signature of Applicant:  Date: 8/28/19Title: President Company Name: The VMC Group

"Access to Safe, Quality Healthcare Environments that Meet California's Diverse

STATE OF CALIFORNIA – HEALTH AND HUMAN SERVICES AGENCY  
OSH-FD-759 (REV 12/16/15)

Page 1 of 3

## Single Package R-410A Air Conditioner

Project Name: **3507 - Port Neches, TX**Unit Model #: **ZJ061N08D4B5GCB2R3**Quantity: **1** Tag #: **RTU-3**

### Seismic Certification



## OFFICE OF STATEWIDE HEALTH PLANNING AND DEVELOPMENT FACILITIES DEVELOPMENT DIVISION

### California Licensed Structural Engineer Responsible for the Engineering and Test Report(s)

Company Name: The VMC GroupName: Kenneth Tarlow California License Number: SE-2851Mailing Address: 113 Main Street, Bloomingdale, NJ 07403Telephone: (973) 838-1780 Email: [ken.tarlow@thevmcgroup.com](mailto:ken.tarlow@thevmcgroup.com)

### Supports and Attachments Preapproval

- Supports and attachments are preapproved under OPM- \_\_\_\_\_  
(Separate application for OSHPD Preapproval of Manufacturer's Certification (OPM) of Supports and attachments is required)
- Supports and attachments are not preapproved

### Certification Method

- Testing in accordance with:  ICC-ES AC156
- Other (Please Specify): \_\_\_\_\_

### Testing Laboratory

Company Name: DCL LabsContact Name: Josh Sailer, Laboratory ManagerMailing Address: 1315 Greg Street, Suite 109, Sparks, NV 89431Telephone: (775) 358-5085 Email: [josh@shaketest.com](mailto:josh@shaketest.com)

"Access to Safe, Quality Healthcare Environments that Meet California's Diverse

STATE OF CALIFORNIA – HEALTH AND HUMAN SERVICES AGENCY  
OSH-FD-759 (REV 12/16/15)



Page 2 of 3

## Single Package R-410A Air Conditioner

Project Name: **3507 - Port Neches, TX**

Unit Model #: **ZJ061N08D4B5GCB2R3**

Quantity: **1** Tag #: **RTU-3**

### Seismic Certification



## OFFICE OF STATEWIDE HEALTH PLANNING AND DEVELOPMENT FACILITIES DEVELOPMENT DIVISION

### Seismic Parameters

Design in accordance with ASCE 7-16 Chapter 13:  Yes  No

Design Basis of Equipment or Components ( $F_p/W_p$ ) = Rigid Curb = 1.5; Spring Isolated Curb = 4.5

$S_{DS}$  (Design spectral response acceleration at short period, g) = 2.00

$a_p$  (In-structure equipment or component amplification factor) = 2.5

$R_p$  (Equipment or component response modification factor) = Rigid Curb = 6.0; Spring Isolated Curb = 2.0

$\Omega_0$  (System overstrength factor) = 2.0

$I_p$  (Importance factor) = 1.5

$z/h$  (Height factor ratio) = 1

Equipment or Component Natural Frequencies (Hz) = See attachment

Overall dimensions and weight (or range thereof) = See attachment

Equipment or Components @ grade designed in accordance with ASCE 7-16 Chapter 15:  Yes  No

Design Basis of Equipment or Components ( $V/W$ ) = \_\_\_\_\_

$S_{DS}$  (Design spectral response acceleration at short period, g) = \_\_\_\_\_

$S_{D1}$  (Design spectral response acceleration at 1 second period, g) = \_\_\_\_\_

$R$  (Response modification coefficient) = \_\_\_\_\_

$\Omega_0$  (System overstrength factor) = By: Timothy J Piland

$C_d$  (Deflection amplification factor) = \_\_\_\_\_

$I_p$  (Importance factor) = 1.5

Height to Center of Gravity above base = \_\_\_\_\_

Equipment or Component Natural Frequencies (Hz) = \_\_\_\_\_

Overall dimensions and weight (or range thereof) = \_\_\_\_\_

Tank(s) designed in accordance with ASME BPVC, 2015:  Yes  No

### List of Attachments Supporting Special Seismic Certification

Test Report(s)  Drawings  Calculations  Manufacturer's Catalog

Other(s) (Please Specify): \_\_\_\_\_

### OSHPD Approval (For Office Use Only) – Approval Expires on December 31, 2025

Signature:  Date: March 8, 2021

Print Name: Timothy J. Piland Title: SSE

Special Seismic Certification Valid Up to:  $S_{DS}$  (g) = 2.00  $z/h$  = 1

Condition of Approval (if applicable): \_\_\_\_\_

"Access to Safe, Quality Healthcare Environments that Meet California's Diverse

STATE OF CALIFORNIA – HEALTH AND HUMAN SERVICES AGENCY  
OSH-FD-759 (REV 12/16/15)

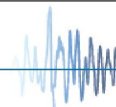

## Single Package R-410A Air Conditioner

Project Name: **3507 - Port Neches, TX**

Unit Model #: **ZJ061N08D4B5GCB2R3**

Quantity: **1** Tag #: **RTU-3**

### Seismic Certification

**Table 1 - Certified Components**

Manufacturer: Johnson Controls and other Unitary Product Group brands (York, Coleman, Luxaire, Evcon, Fraser-Johnston and Ready Ship)

Product Line: JCI Packaged Rooftop Units

Product Construction: Cabinets constructed of G90 galvanized 1,000 hour salt spray (per ASTM-B117) rated powder-coated 20 gage carbon steel wrapper and duct panel with integral corner posts, all attached at the base to four (4) full perimeter 14 gage base rails with #10 sheet metal screws.

Options: 230-575 V, economizer, power exhaust, electric or gas heater, variable frequency drive

Mounting Description: Rigid or Flexible Curb Mounting

Product Line	Model Number <sup>2</sup>	Dimensions (inches)			Operating Weight (lb)	Nominal Cooling Capacity (Tons)	Sds (g), z/h=1	Unit
		Depth	Width	Height				
Predator Air Handling Units (Short)	ZH/ZU/JA3 037	89	59	42	860 <sup>1</sup>	3	2.0	3
	ZJ/ZW/JA3 037	89	59	42	740	3		Interpolated
	ZR/ZK/JA3 037	89	59	42	980 <sup>1</sup>	3		1
	ZT/ZV/JA3 037	89	59	42	922	3		Interpolated
	ZH/ZU/JA4 049	89	59	42	763	4		Interpolated
	ZJ/ZW/JA4 049	89	59	42	762	4		Interpolated
	ZR/ZK/JA4 049	89	59	42	880	4		Interpolated
	ZT/ZV/JA4 049	89	59	42	960	4		Interpolated
	ZH/ZU/JA5 061	89	59	42	772	5		Interpolated
	ZJ/ZW/JA5 061	89	59	42	1,070 <sup>1</sup>	5		4
	ZR/ZK/JA5 061	89	59	42	1,070 <sup>1</sup>	5		2
	ZT/ZV/JA5 061	89	59	42	968	5		Extrapolated
Predator Air Handling Units (Standard)	XP/XA/J06 078	89	59	42	970 <sup>1</sup>	6.5	2.0	7
	ZF/ZS/J06 078	89	59	42	1,090 <sup>1</sup>	6.5		10
	ZH/ZU/J06 078	89	59	42	910	6.5		Interpolated
	ZJ/ZW/J06 078	89	59	51	1030	6.5		Interpolated
	ZR/ZK/J06 078	89	59	51	1,060 <sup>1</sup>	6.5		5
	ZF/ZS/J07 090	89	59	42	860	7.5		Interpolated
	ZH/ZU/J07 090	89	59	42	910	7.5		Interpolated
	ZJ/ZW/J07 090	89	59	51	1,081	7.5		Interpolated
	XP/XA/J07 090	89	59	42	920	7.5		Interpolated
	ZR/ZK/J07 090	89	59	42	965	7.5		Interpolated
	ZF/ZS/J08 102	89	59	51	1,020	8.5		Interpolated
	ZH/ZU/J08 102	89	59	51	1,030	8.5		Interpolated
	ZJ/ZW/J08 102	89	59	51	1,060	8.5		Interpolated
	XP/XA/J08 102	89	59	51	1,135	8.5		Interpolated
	ZR/ZK/J08 102	89	59	51	1,200	8.5		Interpolated
	ZF/ZS/J10 120	89	59	51	1,060	10		Interpolated
	ZH/ZU/J10 120	89	59	51	1,090	10		Interpolated
	ZJ/ZW/J10 120	89	59	51	1,070	10		Interpolated
	XP/XA/J10 120	89	59	51	1,135	10		Interpolated
	ZR/ZK/J10 120	89	59	51	1,200	10		Interpolated
	ZF/ZS/J12 150	119.5	59	51	1,253	12.5		Interpolated
	ZH/ZU/J12 150	119.5	59	51	1,250 <sup>1</sup>	12.5		11
	XP/XA/J12 150	119.5	59	51	1,510 <sup>1</sup>	12.5		8
	ZJ/ZW/J12 150	119.5	59	51	1,570 <sup>1</sup>	12.5		9
ZR/ZK/J12 150	119.5	59	51	1,600 <sup>1</sup>	12.5	6		
Predator Air Handling Units (Ultra High Efficiency)	ZT/ZV 120	119.5	59	51	1,470 <sup>1</sup>	10	2.0	12
	ZT/ZV 078	119.5	59	51	1,550	6.5		Interpolated
	ZT/ZV 090	119.5	59	51	1,550	7.5		Interpolated
	ZT/ZV 102	119.5	59	51	1,575	8.5		Interpolated
	ZT/ZV 150	119.5	59	51	1,680 <sup>1</sup>	12.5		13

1. Weights listed for tested units are actual, not approximate weights. The weights listed for interpolated units are maximum weights, assuming all optional features are included. Optional features are summarized in the table below.

2. Model numbers are generalized for each type of unit and the associated BTU tonnage that the unit can output.

Unit Accessory	Operating Weight (lbs.)
Economizer	85
Power Exhaust	35
Electric Heat	49
Gas Heat	110
Variable Frequency Drive	30

1. Weight given is for the maximum electric heater size available.

2. Weight given for the gas heater is for the maximum number of tube heat exchangers available (8 tube).

3. Weight includes mounting hardware, controls and manual bypass option.

**Date**

01/06/2022

**Project Name**

3507 - Port Neches, TX

**Project Number**

**Client / Purchaser**

### Guide Specification Summary Page

---

<b>Product Series</b>	<b>Models and Unit Tags</b>	
15-25 Sunline Magnum	ZT180N30R4B5GCB2C1	RTU-1
York® Sun™ Pro 3-12.5 Ton Package	ZT120N18R4B5GCL2R1	RTU-2
	ZJ061N08D4B5GCB2R3	RTU-3

---

## GENERAL

York Sunline Magnum units are convertible single package units. for efficient part load operation and maximum comfort control. Although the units are primarily designed for curb mounting on a roof, they can also be slab-mounted at ground level or set on steel beams above a finished roof. Cooling only, cooling with gas heat and cooling with electric heat models are available with a wide variety of factory-mounted options and field-installed accessories to make them suitable for almost every application. All units are self-contained and assembled on full perimeter base rails with holes in the four corners for overhead rigging. Every unit is completely piped, wired, charged and tested at the factory to simplify the field installation and to provide years of dependable operation. All models (including those with an economizer) are suitable for either bottom or horizontal duct connections. Models with power exhaust are suitable for bottom duct connections only. For bottom duct, remove the sheet metal panels from the supply and return air openings through the base of the unit. or horizontal duct, replace the supply and return air panels on the rear of the unit with a side duct flange accessory. All supply air blowers are equipped with a belt drive that can be adjusted to meet exact requirements of the job. A high static drive option is available for applications with a higher CFM and/or static pressure requirement.

All compressors include crankcase heat and internal pressure relief. Every refrigerant circuit includes an expansion valve, a liquid line filter-drier, a discharge line high pressure switch and a suction line with a freestart and low pressure/loss of charge switch. The unit control circuit includes a 75 VA transformer, a 24-volt circuit breaker and a relay board with two compressor lockout circuits, a terminal strip for thermostat wiring, plus an additional set of pin connectors to simplify the interface of additional field controls. All units have long lasting powder paint cabinets with 750 hour salt spray test approval under ASTM-B117 procedures. All models are CSA approved. All models include a 1-year limited warranty on the complete unit. Compressors and electric heater elements carry an additional 4-year warranty. Aluminumized steel tubular heat exchangers carry an additional 9-year warranty.

## DESCRIPTION

They shall have built-in field convertible duct connections for down discharge supply/return or horizontal discharge supply/ return, and be available with factory installed options or field installed accessories. The units shall be factory wired, piped, charged with R-410A refrigerant and factory tested prior to shipment. All unit wiring shall be both numbered and color coded. All units shall be manufactured in a facility certified to ISO 9001 standards and the cooling performance shall be rated in accordance with DOE and AHRI test procedures. Units shall be CSA

listed, classified to ANSIZ21.47 standards, UL 1995/ CAN/CSA No. 236-M90 conditions.

## UNIT CABINET

Unit cabinet shall be constructed of galvanized steel, with exterior surfaces coated with a non-chalking, powdered paint finish, certified at 750 hours salt spray test per ASTM-B117 standards. Indoor blower section shall be insulated with a minimum 1/2" thick insulation, coated on the airside. Aluminum foil faced insulation shall be used in the furnace compartment and be fastened with ridged fasteners to prevent insulation from entering the air stream. Cabinet panels shall be "large" size, easily removable for servicing and maintenance. Full perimeter base rails shall be provided to assure reliable transit of equipment, overhead rigging and proper sealing on roof curb applications. Disposable 2" filters shall be furnished and be accessible through a removable access door, sealed airtight. Units filter track shall be designed to accommodate either 2" or 4" filters. Fan performance measuring ports shall be provided on the outside of the cabinet to allow accurate air measurements of evaporator fan performance without removing panels or creating air by-pass of the coils. Condensate pan shall be internally sloped and conform to ASHRAE 62-89 selfdraining standards. Condensate connection shall be a minimum of 1" I.D. female and be a ridged mount connection. Unit shall incorporate a fixed outdoor air damper with an outdoor air intake opening covered with a bird screen and a rain hood painted to match the exterior of the unit.

## INDOOR (EVAPORATOR) FAN ASSEMBLY

Fan shall be a belt drive assembly and include an adjustable- pitch motor pulley. Job site selected (B.H.P.) brake horsepower shall not exceed the motors nameplate horsepower rating, plus the service factor. Units shall be designed not to operate above service factor. Fan wheel shall be double-inlet type with forward-curved blades, dynamically balanced to operate smoothly throughout the entire range of operation. Airflow design shall be constant air volume.

**IntelliSpeed™ Supply Fan Control Option (ASHRAE 90.1 compliant, section 6.4.3.10)** – Units configured with the IntelliSpeed™ Supply Fan Option will contain a VFD for variable volume supply fan operation. This option allows the supply fan RPM to vary based on the number of compressors or heating stages energized. The economizer's minimum position will also be configurable to vary based on the supply fan VFD frequency output.

## OUTDOOR (CONDENSER) FAN ASSEMBLY

The outdoor fans shall be of the direct-driven propeller type, discharge air vertically, have aluminum blades riveted to corrosion resistant steel spider brackets and shall be dynamically balanced for smooth operation. The 4 outdoor fan motors shall be totally enclosed with

permanently lubricated bearings, internally protected against overload conditions and staged independently.

## REFRIGERANT COMPONENTS

### Compressors:

- a. Shall be Scroll compressors internally protected with internal high-pressure relief and over temperature protection.
- b. Shall have internal spring isolation and sound muffling to minimize vibration and noise, and be externally isolated on a dedicated, independent mounting.

### Coils:

- a. Evaporator and condenser coils shall have aluminum plate fins mechanically bonded to seamless internally enhanced copper tubes with all joints brazed. Special Phenolic coating shall be available as a factory option
- b. Evaporator and Condenser coils shall be of the direct expansion, draw-thru, design

### Refrigerant Circuit and Refrigerant Safety Components shall include:

- Balance-port thermostatic expansion valve with independent circuit feed system.
- Filter drier/strainer to eliminate any moisture or foreign matter.
- Accessible service gage connections on both suction and discharge lines to charge, evacuate, and measure refrigerant pressure during any necessary servicing or troubleshooting, without losing charge.
- The refrigeration system shall provide at least 15° F of sub-cooling at design conditions.

### Unit Controls:

- a. Unit shall be complete with self-contained low-voltage control circuit protected by a resettable circuit breaker on the 24-volt transformer side
- b. Unit shall incorporate a lockout circuit which provides reset capability at the space thermostat or base unit, should any of the following standard safety devices trip and shut off compressor
- c. Loss-of-charge/Low-pressure switch. (1) High-pressure switch, (2) Freeze-protection thermostat, evaporator coil. If any of the above safety devices trip, a LED (light-emitting diode) indicator shall flash a diagnostic code that indicates which safety switch has tripped

- d. Unit shall incorporate "AUTO RESET" compressor over temperature, over current protection
- e. Unit shall operate with conventional thermostat designs and have a low voltage terminal strip for easy hook-up
- f. Unit control board shall have on-board diagnostics and fault code display
- g. Standard controls shall include anti-short cycle and low voltage protection, and permit cooling operation down to 0 °F
- h. Control board shall monitor each refrigerant safety switch independently
- i. Control board shall retain last 5 fault codes in non volatile memory, which will not be lost in the event of a power loss

## GAS HEATING SECTION

Shall be designed with induced draft combustion with post purge logic and energy saving direct spark ignition, redundant main gas valve. Ventor wheel shall be constructed of stainless steel for corrosion resistance. The heat exchanger shall be of the tubular type, constructed of T1-40 aluminized steel for corrosion resistance and allowing minimum mixed air entering temperature of 25 °F. Burners shall be of the in-shot type, constructed of aluminum coated steel and contain air mixture adjustments. All gas piping shall enter the unit cabinet at a single location through either the side or curb, without any field modifications. An integrated control board shall provide timed control of evaporator fan functioning and burner ignition. Heating section shall be provided with the following minimum protection:

- a. Primary and auxiliary high-temperature limit switches.
- b. Induced draft motor speed sensor.
- c. Flame roll out switch (automatic reset).
- d. Flame proving controls. Unit shall have two independent stages of capacity.

## UNIT OPERATING CHARACTERISTICS

Unit shall be capable of starting and running at 125° F outdoor temperature, exceeding maximum load criteria of AHRI Standard 340/360. The compressor, with standard controls, shall be capable of operation down to 25° F outdoor temperature. Accessory low ambient kit shall be available for operation to 0° F. Unit shall be provided with fan time delay to prevent cold air delivery before heat exchanger warms up.

## ELECTRICAL REQUIREMENTS

All unit power wiring shall enter unit cabinet at a single factory provided location and be capable of side or bottom entry, to minimize roof penetrations and avoid unit field

modifications. Separate side and bottom openings shall be provided for the control wiring.

### STANDARD LIMITED WARRANTIES

- Compressor 5 Years
- Heat Exchanger 10 Years
- Other Parts 1 Year

### OPTIONAL OUTDOOR AIR

Shall be made available by either/or:

- **Dry Bulb Economizer** – Outdoor and return air dampers that are interlocked and positioned by a fully-modulating, spring-return damper actuator. The maximum leakage rate for the outdoor air intake dampers shall be designed to meet ASHRAE 90.1-2010, AMCA 511 Class 1A damper, and the International Energy Conservation Code (IECC) certification requirements by achieving leakage rates of 3 cfm/sq. ft. at 1" of static pressure. During economizer operation, a mixed-air temperature control shall modulate the outdoor and return air damper assembly to prevent the supply air temperature from dropping below 55°F. Changeover from compressor to economizer operation shall be provided by an integral electronic enthalpy control that feeds input into the basic module. The outdoor intake opening shall be covered with a rain hood that matches the exterior of the unit. Water eliminator/filters shall be provided. Simultaneous economizer/compressor operation is also possible. Dampers shall fully close on power loss.

### OTHER FACTORY INSTALLED OPTIONS

- **ElectroFin® E-coat Epoxy Polymer Coated Condenser Coil** - The condenser coils are coated with an epoxy polymer coating to protect against corrosion.
- **Phase Monitor** - Designed to prevent unit damage. The phase monitor will shut the unit down in an out-of phase condition.
- **Non-powered GFI Convenience Outlet**
- **Hinged/"Tool Free" Blower, Blower Motor, Filter And Electric Access Panels** - This option allows for complete hinged and tool free access to the unit's blower, blower motor, filters and electrical panel sections. NOTE: Knobs are shipped separately within the unit to prevent shipping damage. These must be field installed for tool free operation.
- **High Static Drive**
- **2" Pleated Filters, MERV 8**
- **Disconnect Switch** - For gas heat units and cooling units with electric heat, a HACR breaker sized to the unit is provided.

### FIELD INSTALLED OPTIONS

## GENERAL

York® Sun™ Pro units are convertible single packages with a common footprint cabinet and common roof curb for all 3 through 12-1/2 ton models. All 6-1/2 through 12-1/2 ton have two compressors with independent R-410A refrigeration circuits to provide 2 stages of cooling. The units were designed for light commercial applications and can be easily installed on a roof curb, slab, or frame. All units are self contained and assembled on rigid full perimeter base rails allowing for 3-way forklift access and overhead rigging. Every unit is completely charged with R-410A, wired, piped, and tested at the factory to provide a quick and easy field installation. All units are convertible between side and down airflow. Independent economizer designs are used on side and down discharge applications, as well as all tonnage sizes. Predator® units are available in the following configurations: cooling only, cooling with electric heat, cooling with gas heat, reheat only, reheat with electric heat and reheat with gas heat. Electric heaters are available as factory-installed options or field-installed accessories.

## DESCRIPTION

Units shall be factory assembled, single package, (Elec/Elec, Gas/ Elec), designed for outdoor installation. They shall have built in field convertible duct connections for down discharge supply/return or horizontal discharge supply/return and be available with factory installed options or field installed accessories. The units shall be factory wired, piped and charged with R-410A refrigerant and factory tested prior to shipment. All unit wiring shall be both numbered and color coded. The cooling performance shall be rated in accordance with DOE and AHRI test procedures. Units shall be CSA certified to ANSI Z21.47 and UL 1995/CAN/CSA No. 236-M90 standards.

## UNIT CABINET

Unit cabinet shall be constructed of galvanized steel with exterior surfaces coated with a non-chalking, powder paint finish, certified at a 750-hour salt spray test per ASTM-B117 standards. Indoor blower sections shall be insulated with up to 1" thick insulation coated on the airside. Either aluminum foil faced or elastometric rubber insulation shall be used in the unit's compartments and be fastened to prevent insulation from entering the air stream. Cabinet doors shall be hinged with toolless access for easy servicing and maintenance. Full perimeter base rails shall be provided to assure reliable transit of equipment, overhead rigging, fork truck access and proper sealing on roof curb applications. Disposable 2" filters shall be furnished as standard and be accessible through hinged access door. Fan performance measuring ports shall be provided on the outside of the cabinet to allow accurate air measurements of evaporator fan performance without

removing panels or creating bypass of the coils. Condensate pan shall be slide out design, constructed of a non corrosive material, internally sloped and conforming to ASHRAE 62-B9 standards. Condensate connection shall be a minimum of 3/4" I.D. female and be rigid mount connection.

## INDOOR (EVAPORATOR) FAN ASSEMBLY

Fan shall be a belt drive assembly and include an adjustable pitch motor pulley. Job site selected brake horsepower shall not exceed the motors nameplate horsepower rating plus the service factor. Units shall be designed to operate within the service factor. Fan wheel shall be double inlet type with forward curve blades, dynamically balanced to operate smoothly throughout the entire range of operation. Airflow design shall be constant volume. Bearings shall be sealed and permanently lubricated for longer life and no maintenance. Entire blower assembly and motor shall be slide out design.

## OUTDOOR (CONDENSER) FAN ASSEMBLY

The outdoor fans shall be of the direct drive type, discharge air vertically, have aluminum blades riveted to corrosion resistant steel spider brackets and shall be dynamically balanced for smooth operation. The outdoor fan motors shall have permanently lubricated bearings internally protected against overload conditions and staged independently. A cleaning window shall be provided on two sides of the units for coil cleaning.

## REFRIGERANT COMPONENTS

### Compressors:

- a. Shall be fully hermetic type, direct drive, internally protected with internal high-pressure relief and over temperature protection. The hermetic motor shall be suction gas cooled and have a voltage range of + or - 10% of the unit nameplate voltage.
- b. Shall have internal spring isolation and sound muffling to minimize vibration and noise, and be externally isolated on a dedicated, independent mounting.

### Coils:

- a. Evaporator coils shall have aluminum plate fins mechanically bonded to seamless internally enhanced copper tubes with all joints brazed. Special Phenolic coating shall be available as a factory option.
- b. Evaporator coils shall be of the direct expansion, draw-thru design.
- c. Condenser coils shall have aluminum plate fins mechanically bonded to seamless internally enhanced copper tubes with all joints brazed or Micro-Channel aluminum tube, aluminum fins.
- d. Condenser coils shall be of the draw-thru design.

Refrigerant Circuit and Refrigerant Safety Components shall include:

- a. Independent fixed-orifice or thermally operated expansion devices.
- b. Solid core filter drier/strainer to eliminate any moisture or foreign matter.
- c. Accessible service gage connections on both suction and discharge lines to charge, evacuate, and measure refrigerant pressure during any necessary servicing or troubleshooting, without losing charge.
- d. The 6-1/2 through 12-1/2 ton unit shall have two independent refrigerant circuits, equally split in 50% capacity increments.

Unit Controls:

- a. Unit shall be complete with self-contained low-voltage control circuit protected by a resettable circuit breaker on the 24-volt transformer side.
- b. Unit shall incorporate a lockout circuit which provides reset capability at the space thermostat or base unit should any of the following standard safety devices trip and shut off compressor:
  - Loss-of-charge/Low-pressure switch.
  - High-pressure switch.
  - Freeze condition sensor on evaporator coil. If any of these safety devices trip, the LCD screen will display the alarm message.
- c. Unit shall incorporate "AUTO RESET" compressor over temperature, over current protection.
- d. Unit shall operate with conventional thermostat designs and have a low voltage terminal strip for easy hook-up.
- e. Unit control board shall have on-board diagnostics and fault message display.
- f. Standard controls shall include anti-short cycle and low voltage protection, and permit cooling operation down to a selectable value as low as 0 °F.
- g. Control board shall monitor each refrigerant safety switch independently.

**GAS HEATING SECTION**

Heat exchanger and exhaust system shall be constructed of aluminized steel, and be designed with induced draft combustion with post purge logic, energy saving direct spark ignition, and redundant main gas valve. The heat exchanger shall be of the tubular type, constructed of T1-40 aluminized steel for corrosion resistance and allowing minimum mixed air entering temperature of 40 °F. Burners shall be of the in-shot type, constructed of aluminum-coated steel. All gas piping shall enter the unit cabinet at a single location, through either the side or bottom, without any field modifications. An integrated control board shall provide timed control of evaporator fan functioning and burner ignition. Heating section shall be provided with the following minimum protection:

- a. Primary and auxiliary high-temperature limit switches.
- b. Induced draft pressure sensor.
- c. Flame roll out switch (manual reset).
- d. Flame proving controls.
- e. All two stage gas units shall have two independent stages of capacity (70% or 75% 1st stage, 100% 2nd stage) 3 through 5 ton and (60% 1st stage, 100% 2nd stage) 6-1/2 through 12-1/2 ton.

**UNIT OPERATING CHARACTERISTICS**

Unit shall be capable of starting and running at 125 °F outdoor temperature, exceeding maximum load criteria of AHRI Standard 340/360. The compressor, with standard controls, shall be capable of operation down to 0 °F outdoor temperature. Unit shall be provided with fan time delay to prevent cold air delivery before heat exchanger warms up. (Gas heat only)

**ELECTRICAL REQUIREMENTS** - All unit power wiring shall enter unit cabinet at a single factory provided location and be capable of side or bottom entry to minimize roof penetrations and avoid unit field modifications. Separate side and bottom openings shall be provided for the control wiring.

**STANDARD LIMITED WARRANTIES** - Compressor – 5 Years, Heat Exchanger – 10 Years, Elect. Heat Elem. – 5 Years, Parts – 1 Year.

**FACTORY INSTALLED OPTIONAL OUTDOOR AIR**  
(Shall be made available by either/or):

- **DRY BULB AUTOMATIC ECONOMIZER** – Outdoor and return air dampers that are interlocked and positioned by a fully-modulating, spring-return damper actuator. The maximum leakage rate for the outdoor air intake dampers shall be designed to meet ASHRAE 90.1, AMCA 511 Class 1A damper, and the International Energy Conservation Code (IECC) certification requirements by achieving leakage rates of 3 CFM/sq. ft. at 1" of static pressure. Changeover from compressor to economizer operation shall be provided by an integral electronic enthalpy control that feeds input into the basic module. The outdoor intake opening shall be covered with a rain hood that matches the exterior of the unit. Water eliminator/filters shall be provided. Simultaneous economizer/compressor operation is also possible. Dampers shall fully close on power loss.

#### **ADDITIONAL FACTORY INSTALLED OPTIONS**

- **Alternate Indoor Blower Motor** – For applications with high restrictions, units are available with optional indoor blower motors that provide higher static output and/or higher airflow.
- **IntelliSpeed™ Supply Fan Control Option (ASHRAE 90.1 compliant, section 6.4.3.10)** – Units configured with the IntelliSpeed™ Supply Fan Option will contain a VFD for variable volume supply fan operation. This option allows the supply fan RPM to vary based on the number of compressors or heating stages energized. The economizer's minimum position will also be configurable to vary based on the supply fan VFD frequency output.
- **Non-Powered Convenience Outlet** – Unit is provided with a non-powered 120VAC GFCI outlet with cover on the corner of the unit housing the compressors.
- **BAS Controls** – Include supply air sensor, return air sensor, dirty filter indicator and air proving switch.
- **Smoke Detector** – A smoke detector can be factory mounted and wired in the supply and/or return air compartments.
- **ElectroFin® E-coat Epoxy Polymer Coated Condenser Coil** – The condenser coils are coated with an epoxy polymer coating to protect against corrosion.

#### **FIELD INSTALLED OPTIONS**

**Date**

01/06/2022

**Project Name**

3507 - Port Neches, TX

**Project Number**

**Client / Purchaser**

### Control Summary Page

Control	Models and Unit Tags	
BACnet MSTP,MdbS,N2 COM Card	ZT180N30R4B5GCB2C1	RTU-1
	ZT120N18R4B5GCL2R1	RTU-2
	ZJ061N08D4B5GCB2R3	RTU-3

**23 09 23 Direct- digital Control system for HVAC**23 09 23. 13 Decentralized, Rooftop Units:23 09 23. 13.A. Unit Control Board

1. ASHRAE 62- 2001 compliant. BTL certified.
2. Shall accept 20-30 VAC input power, 50/60Hz. 24 VAC nominal.
3. Operating temperature range from -40F to 158F; 10-90% RH (non-condensing UI), and -4F to 158F; 10-90% Rh (non-condensing), with a storage temperature range from -40F to 194F; 5-95% RH (non-condensing).
4. Shall include an option of and Economizer microprocessor controller which communicates directly with the Unit Control Board and has 8 Analog outputs, 2 Analog inputs, 2 Binary outputs, 3 Binary outputs.
5. Controller shall accept the following inputs: space temperature, return air temperature sensor, setpoint adjustment, outdoor air temperature, indoor air quality, outdoor air quality, indoor relative humidity, compressor lock- out, fire/smoke shutdown, single and dual enthalpy, fan status, remote time clock, SA Bus communicated temperature/humidity/CO2 values from Network sensors, FC Bus Network Overrides for space temperature, outdoor air temperature, space humidity, outdoor air quality, Indoor air quality, System purge.
6. Shall accept a single CO2 sensor or multiple CO2 sensors networked together via communication bus in the conditioned space, and be Demand Control Ventilation (DCV) ready.
7. Shall provide the following outputs: economizer, fan, cooling stage 1, cooling stage 2, heat stage 1, heat stage 2, heat stage 3/ exhaust/ reversing valve/ dehumidify/occupied.
8. Unit shall provide surge protection for the controller through a circuit breaker.
9. Shall be Internet capable, and communicate at a Baud rate of 38.4K or faster.
10. Shall have an LED display independently showing the status of activity on the communication bus, and processor operation.
11. Unit shall incorporate a lockout circuit which provides reset capability at the space thermostat or base unit should any of the following standard safety devices trip and shut off compressor. If any of these safety devices trip, the LCD screen will display alarm message indicating the specific safety device that caused the lockout.
  - a. Loss of charge/Low-pressure switch.
  - b. High-pressure switch.
  - c. Freeze condition sensor on evaporator coil.
12. Unit control board must support each usage case:
  - a. Conventional thermostat with low voltage input terminals for easy installation
  - b. Communicating network sensors in the occupied space to provide feedback on space conditions for unit control board to compare with associated setpoints
  - c. Communication via BACnet MS/TP, Modbus RTU, N2 protocols for integration into a building automation/management system
13. Anti-short cycle and low voltage protection features included.
14. Internal occupied/unoccupied scheduling
15. Unit control board shall permit cooling operation down to a selectable value as low as 0 degrees F.
16. Shall allow for start-up, commissioning, troubleshooting, parameter adjustment, setpoint adjustment via onboard display and navigable menu with no additional interface tool or controls technician required.
17. The unit control board shall run a self-test diagnostics algorithm at startup that operated the cooling cycle, heating cycle, fan operation. A status report shall be provided upon completion of the diagnostic self-test.
18. Utilize any wi-fi enabled smart device to access the HVAC or multiple HVAC units if communication wiring between them is present (FC Bus or SA Bus). Remote access shall allow complete ability to perform start-up, commissioning, troubleshooting, parameter adjustment, setpoint adjustment.
19. Local embedded trending and scheduling. Trending data and occupancy scheduling predefined from the factory. Occupancy schedule to be modified via control board joystick menu navigation and remotely using a smart device (cellular phone, laptop, tablet)
20. A menu on the onboard screen shall display the unit status and allow changing parameters where applicable. These include but are not limited to:
  - a. Demand Ventilation Mode – enable or disable
  - b. Operational Setpoint – display current value
  - c. Supply Air Temperature (SAT) – display current value
  - d. Return Air Temperature (RAT) – display current value

- e. Operational Supply Humidity (OprSH) – display current value as provided by a 0-10VDS input, SA Bus Network Sensor, or FC Bus communicated value
  - f. Return Air Humidity (RAH) – display current value
  - g. Operational outdoor Air Temperature (OprOAT) – enthalpy calculated from OAH 0-10VDC input to Economizer board and OprOAT only if economizer is present
  - h. Operational Outdoor Air Humidity (OprOAH) – the buffered outdoor air humidity. May be from economizer boards OAH 0-10VDC input or FC Bus communicated value
  - i. Operational outdoor Air Quality (OprOAQ) – the buffered outdoor air quality in use. May be from economizer boards OAH 0-10VDC input or FC Bus communicated value
  - j. Operational Indoor Air Quality (OprIAQ) – the buffered indoor air quality in use. May be from economizer board IAQ 0-10VDC input, SA Bus Network Sensor, or FC Bus communicated value
21. A menu shall display and allow modification to the following operations and settings:
- a. HVAC Zone Fan
  - b. Cooling
  - c. Heating
  - d. Economizer
  - e. Demand Ventilation
  - f. Power Exhaust
  - g. Sensors
  - h. Network
22. A menu shall display and allow modification to the following operations and settings:
- a. HVAC Zone – Occupied status
  - b. Indoor Fan status
  - c. Cooling status
  - d. Heating status
  - e. Economizer indication whether free-cooling is available or not
  - f. Enabling or disabling of Demand Ventilation
  - g. Power Exhaust
    - 1) Enable/disable hot-gas reheat if available
    - 2) Warmup/Cooldown
    - 3) Title 24 Load Shed
    - 4) Defrost
23. A menu shall display and allow modification to the following operations and settings:
- a. Firmware version (of UCB, Economizer, other peripheral boards)
  - b. Setting time zone
  - c. Network information
    - 1) Device name that will appear on the FC Bus
    - 2) Selection of communication protocol
    - 3) Operational Baud Rate
    - 4) Device ID
24. A menu shall display and allow modification to the following operations and settings:
- a. Version of firmware
  - b. Ability to Load new firmware
  - c. Create a backup file of the firmware and parameter setting via USB port
  - d. Restore factory default parameter values and setup
  - e. Full and Partial Cloning of parameter setpoints from or to other units
  - f. Data trend exporting
25. A menu shall display and allow modification to the following operations and settings:

- a. Unit serial number, model number and name
- b. Ability to reset Lockouts
- c. Controller name
- d. Displays the current values of all setpoints in use
- e. Displays all current values for the indoor and outdoor zones
- f. Displays current values related to:
  - 1) Indoor Fan
  - 2) Cooling
  - 3) Heating
  - 4) Heat Pump operation
  - 5) Economizer operation
  - 6) Power Exhaust
  - 7) Demand Ventilation
  - 8) Air monitoring station
  - 9) Hot Gas Reheat
  - 10) Smoke Control
- g. Current information for inputs; including
  - 1) Sensors
  - 2) Coil Sensors
  - 3) Thermostat
  - 4) Binary Inputs
  - 5) Unit Protection
  - 6) Network Inputs
  - 7) All outputs (relay and binary)
- h. Self-Test
  - 1) A patented self-test system that runs through a series of algorithms to provide a report of all functioning characteristics of the system at time of startup and commissioning.

23 09 23. 13.B. Auxiliary Control Boards

- 1. ASHRAE 62- 2001 compliant. BTL certified.
- 2. Economizer controller CEC Title 24 Compliant
  - a. Display alarms if the following occur
    - 1) Economizer is economizing when conditions do not support
    - 2) Economizer is not economizing when conditions do support
    - 3) Damper Stuck
    - 4) Excess Outdoor Air
    - 5) Failed Sensor
- 3. Refrigeration Fault Detection & Diagnostics
  - a. There is insufficient refrigerant in any circuit
  - b. There is excessive refrigerant in any circuit
  - c. There is excessive refrigerant flow
  - d. There is insufficient refrigerant flow (restriction)
  - e. Inefficient compressor
  - f. Insufficient High-side heat transfer
  - g. Excessive High-side heat transfer (low ambient control problem, low  $\Delta P$ )
  - h. Insufficient Low-side heat transfer
  - i. Excessive Low-side heat transfer

- j. Sensor fault- The liquid temperature is greater than the condenser temperature (Could also be triggered if refrigerant level is very low in the system)
- k. Sensor fault- Sensor data is not available
- l. The unit is off
- m. The ambient temperature is too low
- n. The ambient temperature is too high
- o. The return air wet-bulb temperature is too low
- p. The return air wet-bulb temperature is too high
- q. Sensor fault- The condensing temperature is lower than the ambient temperature (Could also be triggered when the condenser is wet)
- r. The suction line temperature is less than the evaporator temperature
- s. The evaporator temperature is greater than the ambient temperature
- t. The liquid temperature is lower than the ambient temperature
- u. Sensor fault- Suction temperature or ambient temperature is invalid
- v. Sensor fault- The return air dry-bulb or wet-bulb temperature is invalid
- w. Sensor fault- The liquid pressure or suction pressure is invalid
- x. Sensor fault- The suction line temperature is invalid
- y. The return air dry-bulb temperature is too low
- z. The return air dry-bulb temperature is too high
- aa. The Efficiency Index is below 75% of ideal
- bb. The Capacity Index is below 75% of ideal

23 09 23. 13.C Remote Accessibility:

1. ASHRAE 62- 2001 compliant. BTL certified.
2. Provide the ability to adjust parameter values, setpoints, limits remotely
3. Connectivity to an Ethernet network via static IP address or Dynamic Name Server (DNS)
4. Allow a maximum of 100 devices on the same FC bus trunk and accessed by one remote device

# START-UP & SERVICE DATA INSTRUCTION

## COMMERCIAL PACKAGE UNITS

3.0 To 40.0 TONS

---

### START-UP CHECKLIST

Date: \_\_\_\_\_

Job Name: \_\_\_\_\_

Customer Name: \_\_\_\_\_

Address: \_\_\_\_\_

City: \_\_\_\_\_ State: \_\_\_\_\_ Zip: \_\_\_\_\_

Model Number: \_\_\_\_\_ Serial Number: \_\_\_\_\_

Qualified Start-up Technician: \_\_\_\_\_ Signature: \_\_\_\_\_

HVAC Contractor: \_\_\_\_\_ Phone: \_\_\_\_\_

Address: \_\_\_\_\_

Contractor's E-mail Address: \_\_\_\_\_

Electrical Contractor: \_\_\_\_\_ Phone: \_\_\_\_\_

Distributor Name: \_\_\_\_\_ Phone: \_\_\_\_\_

### WARRANTY STATEMENT

Johnson Controls/UPG is confident that this equipment will operate to the owner's satisfaction if the proper procedures are followed and checks are made at initial start-up. This confidence is supported by the 30 day dealer protection coverage portion of our standard warranty policy which states that Johnson Controls/UPG will cover parts and labor on new equipment start-up failures that are caused by a defect in factory workmanship or material, for a period of 30 days from installation. Refer to current standard warranty policy and warranty manual found on UPGnet for details.

In the event that communication with Johnson Controls/UPG is required regarding technical and/or warranty concerns, all parties to the discussion should have a copy of the equipment start-up sheet for reference. A copy of the original start-up sheet should be filed with the Technical Services Department.

The packaged unit is available in constant or variable air volume versions with a large variety of custom options and accessories available. Therefore, some variation in the startup procedure will exist depending upon the products capacity, control system, options and accessories installed.

This start-up sheet covers all startup check points common to all package equipment. In addition it covers essential startup check points for a number of common installation options. Depending upon the particular unit being started not all sections of this startup sheet will apply. Complete those sections applicable and use the notes section to record any additional information pertinent to your particular installation.

Warranty claims are to be made through the distributor from whom the equipment was purchased.

### EQUIPMENT STARTUP

**Use the local LCD or Mobile Access Portal (MAP) Gateway to complete the start-up.**

**A copy of the completed start-up sheet should be kept on file by the distributor providing the equipment and a copy sent to:**

Johnson Controls/UPG  
 Technical Services Department  
 5005 York Drive  
 Norman, OK 73069

**SAFETY WARNINGS**

The inspections and recording of data outlined in this procedure are required for start-up of Johnson Controls/UPG's packaged products. Industry recognized safety standards and practices must be observed at all times. General industry knowledge and experience are required to assure technician safety. It is the responsibility of the technician to assess all potential dangers and take all steps warranted to perform the work in a safe manner. By addressing those potential dangers, prior to beginning any work, the technician can perform the work in a safe manner with minimal risk of injury.

 <b>WARNING</b>
Lethal voltages are present during some start-up checks. Extreme caution must be used at all times.

 <b>WARNING</b>
Moving parts may be exposed during some startup checks. Extreme caution must be used at all times.

**NOTE:** Read and review this entire document before beginning any of the startup procedures.

**DESIGN APPLICATION INFORMATION**

This information will be available from the specifying engineer who selected the equipment. If the system is a VAV system the CFM will be the airflow when the remote VAV boxes are in the

full open position and the frequency drive is operating at 60 HZ. **Do not proceed with the equipment start-up without the design CFM information.**

Design Supply Air CFM: \_\_\_\_\_ Design Return Air CFM: \_\_\_\_\_

Design Outdoor Air CFM At Minimum Position: \_\_\_\_\_

Total External Static Pressure: \_\_\_\_\_

Supply Static Pressure: \_\_\_\_\_

Return Static Pressure: \_\_\_\_\_

Design Building Static Pressure: \_\_\_\_\_

Outside Air Dilution: Economizer Position Percentage: \_\_\_\_\_ CFM: \_\_\_\_\_

Supply Gas Pressure After Regulator W/o Heat Active \_\_\_\_\_ Inches \_\_\_\_\_

ADDITIONAL APPLICATION NOTES FROM SPECIFYING ENGINEER:

## REFERENCE

General Inspection	Completed	See Notes
Unit inspected for shipping, storage, or rigging damage	<input type="checkbox"/>	<input type="checkbox"/>
Unit installed with proper clearances	<input type="checkbox"/>	<input type="checkbox"/>
Unit installed within slope limitations	<input type="checkbox"/>	<input type="checkbox"/>
Refrigeration system checked for gross leaks (presence of oil)	<input type="checkbox"/>	<input type="checkbox"/>
Terminal screws and wiring connections checked for tightness	<input type="checkbox"/>	<input type="checkbox"/>
Filters installed correctly and clean	<input type="checkbox"/>	<input type="checkbox"/>
Economizer hoods installed in operating position	<input type="checkbox"/>	<input type="checkbox"/>
Condensate drain trapped properly, refer to Installation Manual	<input type="checkbox"/>	<input type="checkbox"/>
Economizer damper linkage tight	<input type="checkbox"/>	<input type="checkbox"/>
Gas Heat vent hood installed	<input type="checkbox"/>	<input type="checkbox"/>
All field wiring (power and control) complete	<input type="checkbox"/>	<input type="checkbox"/>

Air Moving Inspection	Completed	See Notes
Alignment of drive components	<input type="checkbox"/>	<input type="checkbox"/>
Belt tension adjusted properly	<input type="checkbox"/>	<input type="checkbox"/>
Blower pulleys tight on shaft, bearing set screws tight, wheel tight to shaft	<input type="checkbox"/>	<input type="checkbox"/>
Pressure switch or transducer tubing installed properly	<input type="checkbox"/>	<input type="checkbox"/>

Exhaust Inspection	Powered <input type="checkbox"/>	Barometric Relief <input type="checkbox"/>	Completed	See Notes
Check hub for tightness			<input type="checkbox"/>	<input type="checkbox"/>
Check fan blade for clearance			<input type="checkbox"/>	<input type="checkbox"/>
Check for proper rotation			<input type="checkbox"/>	<input type="checkbox"/>
Check for proper mounting (screen faces towards unit)			<input type="checkbox"/>	<input type="checkbox"/>
Prove operation by increasing minimum setting on economizer			<input type="checkbox"/>	<input type="checkbox"/>

Economizer Inspection	Standard <input type="checkbox"/>	BAS <input type="checkbox"/>	Completed	See Notes
CO <sub>2</sub> sensor installed Yes <input type="checkbox"/> No <input type="checkbox"/>			<input type="checkbox"/>	<input type="checkbox"/>
Check economizer setting (Reference SSE Control Board LCD menu location)			<input type="checkbox"/>	<input type="checkbox"/>
Prove economizer open/close through SSE Board Setting			<input type="checkbox"/>	<input type="checkbox"/>

Reheat Mode	Normal <input type="checkbox"/>	or Alternate <input type="checkbox"/>	Not Applicable <input type="checkbox"/>
Humidity Sensor (2SH0401) _____			

### Operating Measurements - Air Flow

Fan operates with proper rotation	ID Fans <input type="checkbox"/>	Exh. Fans <input type="checkbox"/>	Cond. Fans <input type="checkbox"/>
Pressure drop across dry evaporator coil (At maximum design CFM) <sup>1</sup>	IWC		
External Static Pressure	IWC		
Return Static Pressure	IWC		
Supply Static Pressure	IWC		
Supply Air CFM Using Dry Coil Chart	CFM		
Final Adjusted Supply Air CFM <sup>2</sup>	CFM		

1. Consult the proper airflow to pressure drop table to obtain the actual airflow at the measured pressure differential.
2. Was a motor pulley adjustment or change required to obtain the correct airflow?  
 Was it necessary to increase or decrease the airflow to meet the design conditions?  
 If the motor pulley size was changed, measure the outside diameters of the motor and blower pulleys and record those diameters here:

Blower Motor HP \_\_\_\_\_ FLA \_\_\_\_\_ RPM \_\_\_\_\_

Pulley Pitch Diameter \_\_\_\_\_ Turns Out \_\_\_\_\_ Final Turns Out \_\_\_\_\_

Blower Pulley Pitch Diameter \_\_\_\_\_ Fixed Sheave \_\_\_\_\_

### ELECTRICAL DATA

T1 - T2 \_\_\_\_\_ Volts                      T2 - T3 \_\_\_\_\_ Volts

Control Voltage \_\_\_\_\_ Volts                      T1 - T3 \_\_\_\_\_ Volts

Device	Nameplate	Measured List All Three Amperages
Supply Fan Motor <sup>1, 2</sup>	AMPS	AMPS
Exhaust Motor (Dampers 100%)	AMPS	AMPS
Condenser Fan #1	AMPS	AMPS
Condenser Fan #2 (if equipped)	AMPS	AMPS
Condenser Fan #3 (if equipped)	AMPS	AMPS
Condenser Fan #4 (if equipped)	AMPS	AMPS
Compressor #1	AMPS	AMPS
Compressor #2 (if equipped)	AMPS	AMPS
Compressor #3 (if equipped)	AMPS	AMPS
Compressor #4 (if equipped)	AMPS	AMPS

1. VAV units with heat section - simulate heat call to drive VAV boxes and VFD/IGV to maximum design airflow position.
2. VAV units without heat section - VAV boxes must be set to maximum design airflow position.



**OPERATIONAL MEASUREMENTS - STAGING CONTROLS**

Verify Proper Operation of Heating/Cooling Staging Controls	
Create a cooling demand at the Thermostat, BAS System or Simplicity SE Verify that cooling/economizer stages are energized.	<input type="checkbox"/>
Create a heating demand at the Thermostat, BAS System or Simplicity SE Verify that heating stages are energized.	<input type="checkbox"/>
Verify Proper Operation of the Variable Frequency Drive (If Required)	
Verify that motor speed modulates with duct pressure change.	<input type="checkbox"/>

**FINAL - INSPECTION**

Verify that all operational control set points have been set to desired value Scroll through all setpoints and change as may be necessary to suit the occupant requirements.	<input type="checkbox"/>
Verify that all option parameters are correct Scroll through all option parameters and ensure that all installed options are enabled in the software and all others are disabled in the software. (Factory software settings should match the installed options)	<input type="checkbox"/>
Verify that all access panels have been closed and secured	<input type="checkbox"/>

**OBSERVED PRODUCT DIFFICIENCIES & CONCERNS:**

---

---

---

---

---

---

---

---

---

---

---

---

---

---

---

---

---

---

---

---

---

---

---

---