

### LIGHT COMMERCIAL ENERGY STAR® CERTIFIED CEILING MOUNT VENTILATORS MODELS L100E, L150E, L200E, L250E & L300E

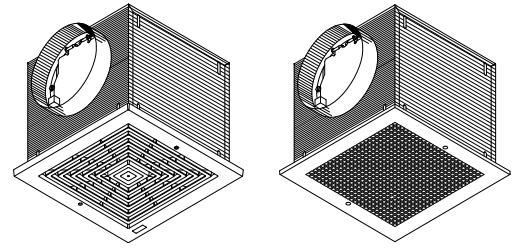

Incredibly reliable. Unbelievably quiet. Offering the CFM choices you need at the lowest sound levels in the industry.

**FEATURES**

**GRILLE:**

- Conceals interior
- Low profile styling blends with any decor
- White plastic (optional metal grille, finished with white enamel paint is available - Model MG1)

**BLOWER:**

- Low RPM for quiet operation
- Resilient anti-vibration mounts
- Dynamically-balanced, centrifugal blower wheel for quiet, efficient performance
- Permanently lubricated, thermally protected motor
- Plug-in motor rated at 120 VAC
- Designed for continuous operation

**HOUSING:**

- Rugged, 20 gauge galvanized steel
- 8" round duct connector
- 1/2" acoustic insulation inside
- Not for use in a cooking area
- May be installed in ceiling or wall (size permitting)
- 8-position mounting brackets for easy installation and greater adaptability to various mounting requirements
- Automatic backdraft damper located within duct connector
- Factory-shipped in horizontal discharge position - easily converted to vertical discharge

**ACCESSORIES (available separately):**

- Model MG1 Metal Grille Cover Upgrade
- Model RD1 Radiation Damper
- Model 80L Electronic Speed Control (Internal)

**TYPICAL SPECIFICATION**

Ventilator shall be Broan Model L100E, (L150E), (L200E), (L250E), (L300E).

Ventilator shall have galvanized steel housing insulated with at least 1/2" of acoustic insulation. Housing to have adjustable mounting brackets.

Automatic backdraft damper to be located within duct connector. Duct connector, blower assembly, and wiring plate shall be adjustable for either horizontal or vertical installation.

Blower unit shall be removable from housing and shall have a dynamically balanced centrifugal-type blower wheel. Motor to be permanently lubricated and mounted with resilient anti-vibration mounts.

Air delivery shall be no less and sound levels no greater than listed for each model. All air and sound ratings shall be certified by AMCA and HVI. Units to be cULus Listed.



Broan-NuTone LLC, 926 West State Street, Hartford, Wisconsin, USA 53027 Broan-NuTone.com 800-558-1711  
 Venmar Ventilation ULC, 550 Lemire Blvd., Drummondville, Québec, Canada J2C 7W9 Broan-NuTone.ca 800-567-3855

REFERENCE	QTY.	REMARKS	Project
			Location
			Architect
			Engineer
			Contractor
			Submitted by <span style="float: right;">Date</span>

# PERFORMANCE RATINGS - LIGHT COMMERCIAL ENERGY STAR® CERTIFIED CEILING MOUNT VENTILATORS L100E, L150E, L200E, L250E & L300E

## AMCA LICENSED PERFORMANCE

MODEL NO.		STATIC PRESSURE (Inches water gage)									NOMINAL RPM	MAX. AMPS @60 Hz	AC VOLTS
		0.0	0.1	0.125	0.25	0.375	0.5	0.625	0.75	0.875			
L100E	CFM Hor.	164	138	132	103	74	40				803	0.3	120
	SONES Hor.	0.2	0.3		0.7								
L100E	CFM Ver.	168	138	131	101	73	38				799	0.3	120
	SONES Ver.	0.1	0.2		0.8								
L150E	CFM Hor.	238	214	209	183	154	122	77			972	0.4	120
	SONES Hor.	1.0	1.0		1.1								
L150E	CFM Ver.	224	203	198	174	146	105	64			990	0.4	120
	SONES Ver.	0.9	0.9		1.0								
L200E	CFM Hor.	267	246	240	214	184	155	109	56		1031	0.5	120
	SONES Hor.	1.5	1.5		1.7								
L200E	CFM Ver.	253	233	228	202	172	123	87	41		1063	0.5	120
	SONES Ver.	1.4	1.3		1.5								
L250E	CFM Hor.	296	277	272	249	223	195	160	108	51	1128	0.6	120
	SONES Hor.	1.9	1.9		1.8								
L250E	CFM Ver.	280	263	259	237	212	185	142	89	40	1144	0.6	120
	SONES Ver.	1.9	1.8		1.8								
L300E	CFM Hor.	343	324	319	295	268	237	204	162	89	1189	0.7	120
	SONES Hor.	3.0	2.9		2.7								
L300E	CFM Ver.	334	315	311	286	258	227	189	150	20	1207	0.7	120
	SONES Ver.	2.9	2.7		2.6								

Performance ratings including the effects of inlet grille and backdraft damper in the airstream. Speed (RPM) shown is nominal. Performance is based on actual speed test. The sound ratings shown are tested to 1/3 octave, Spherical Sones to AMCA 300. Values shown are for installation Type B: Free inlet fan sone levels. Performance shown is for Installation Type B: Unducted inlet, Ducted outlet.

## HVI PERFORMANCE

MODEL NO.	Ducting	0.1" Ps			0.25" Ps	
		CFM	Sones	CFM/Watt	CFM	Sones
L100E	Horizontal	130	0.3	4.9	97	0.8
	Vertical	140	0.3	5.3	101	0.6
L150E	Horizontal	200	1.0	4.6	168	1.4
	Vertical	210	0.7	4.9	178	1.0
L200E	Horizontal	230	1.3	4.4	198	1.5
	Vertical	240	1.0	4.6	209	1.3
L250E	Horizontal	270	1.5	4.5	242	2.0
	Vertical	270	1.4	4.5	242	1.5
L300E	Horizontal	310	2.5	4.2	281	2.5
	Vertical	310	2.5	4.3	282	2.5



Broan-NuTone LLC certifies that the models shown herein are licensed to bear the AMCA Seal. The ratings shown are based on tests and procedures performed in accordance with AMCA Publication 211 (and AMCA Publication 311 if sound is also certified) and comply with the requirements of the AMCA Certified Ratings Program.



All models are UL Listed for use over bathtubs and showers when connected to a GFCI-protected branch circuit (ceiling mount only).



HVI-2100 CERTIFIED RATINGS comply with new testing technologies and procedures prescribed by the Home Ventilating Institute, for off-the-shelf products, as they are available to consumers. Product performance is rated at 0.1 in. static pressure, based on tests conducted in a state-of-the-art test laboratory. Sones are a measure of humanly-perceived loudness, based on laboratory measurements.

## WEIGHT

MODEL NO.	SHIPPING WT.
L100E	18.9 lb.
L150E	19.3 lb.
L200E	19.1 lb.
L250E	21.0 lb.
L300E	21.2 lb.



Broan-NuTone LLC, 926 West State Street, Hartford, Wisconsin, USA 53027 Broan-NuTone.com 800-558-1711  
Venmar Ventilation ULC, 550 Lemire Blvd., Drummondville, Québec, Canada J2C 7W9 Broan-Nutone.ca 800-567-3855

# PERFORMANCE CURVES - LIGHT COMMERCIAL ENERGY STAR® CERTIFIED CEILING MOUNT VENTILATORS

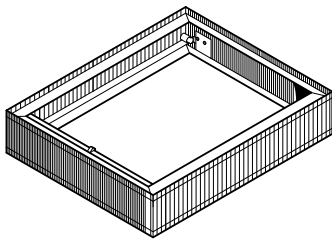
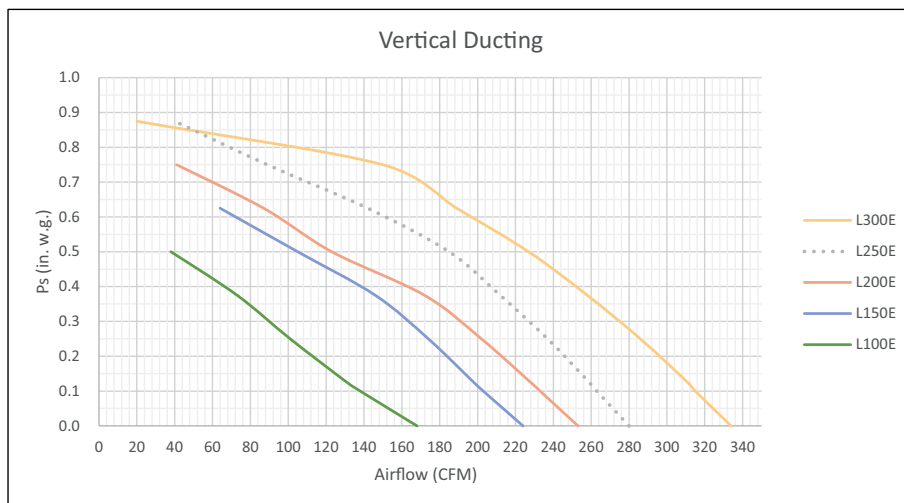
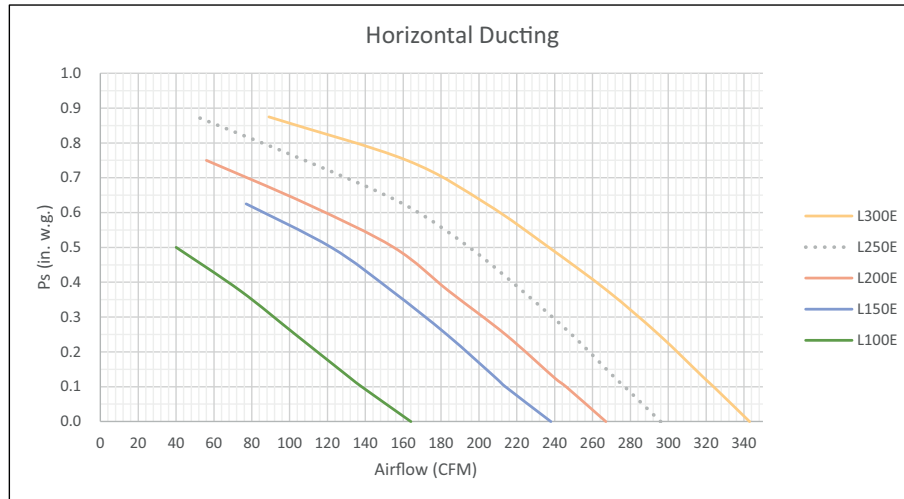

**RADIATION DAMPER  
MODEL RD1  
(AVAILABLE SEPARATELY)**

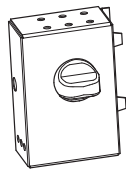

**ELECTRONIC SPEED  
CONTROL (INTERNAL)  
MODEL 80L  
(AVAILABLE SEPARATELY)**

8-in. ROUND  
DUCT  
CONNECTOR

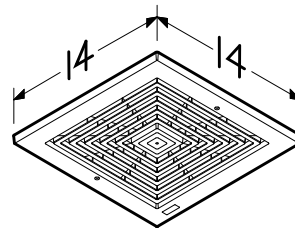
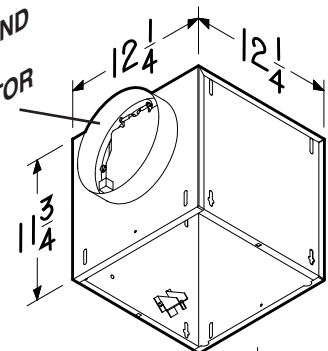

**PLASTIC GRILLE  
(included with  
all models)**

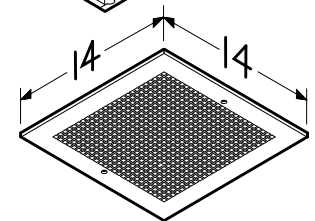

**OPTIONAL  
METAL GRILLE  
MODEL MG1  
(available separately)**

NOTE: Dimensions shown are in inches.



### VENTILATEURS À MONTAGE AU PLAFOND COMMERCIAL LÉGER CERTIFIÉS ENERGY STAR® MODÈLES L100E, L150E, L200E, L250E ET L300E

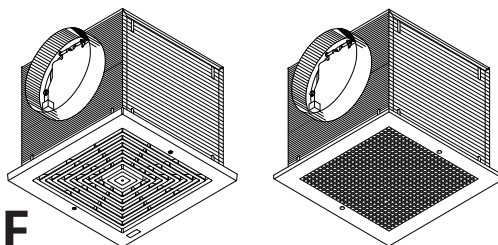

**Incroyablement fiables. Merveilleusement silencieux. Offrent une large gamme de débits d'air (pi³/min) et le plus bas niveau sonore de toute l'industrie.**

#### CARACTÉRISTIQUES

##### GRILLE:

- Dissimule l'intérieur
- Style discret qui s'agence à tout décor
- Grille en plastique blanc (modèle optionel MG1 disponible; grille en métal peinte à l'émail blanc)

##### VENTILATEUR:

- Bas régime de rotation permettant un fonctionnement silencieux
- Amortisseurs anti-vibration résistants
- Roue de ventilateur centrifuge, équilibrée dynamiquement, assurant une performance silencieuse et optimale
- Moteur lubrifié à vie avec protection thermique
- Moteur enfichable, 120 VCA.
- Conçu pour un fonctionnement en continu

##### BOÎTIER:

- Acier galvanisé robuste de calibre 20
- Raccord de conduit rond de 8 po
- Isolant acoustique intérieur de 1/2 po d'épaisseur
- Ne pas utiliser dans une zone de cuisson
- S'installe au plafond ou au mur (si l'espace le permet)
- Supports de montage à 8 positions pour une installation facile et plus de flexibilité envers les requis de montage variés
- Clapet anti-refoulement automatique intégré dans le raccord de conduit
- Livré en configuration d'évacuation de l'air à l'horizontale, mais qui peut être convertie facilement en évacuation de l'air à la verticale

##### ACCESSOIRES (vendus séparément):

- Modèle MG1 : Grille en métal, version améliorée
- Modèle RD1 : Registre coupe-feu
- Modèle 80L : Commande de vitesse électronique (interne)

#### SPÉCIFICATIONS TYPES

Le ventilateur doit être de modèle Broan L100E, (L150E), (L200E), (L250E), (L300E).

Le ventilateur doit avoir d'un boîtier en acier galvanisé avec isolation acoustique d'au moins 1/2 po d'épaisseur. Le boîtier doit être muni de supports de montage ajustables.

Le clapet anti-refoulement automatique doit être intégré dans le raccord de conduit. Le raccord de conduit, le bloc ventilateur ainsi que la plaque de câblage devront permettre une installation horizontale ou verticale.

Le bloc ventilateur doit pouvoir être retiré du boîtier et être pourvu d'une roue de ventilateur équilibrée dynamiquement. Le moteur doit être lubrifié à vie et être installé sur des amortisseurs anti-vibration.

Pour chacun des modèles, le débit de l'air ne doit pas être inférieur et le niveau de bruit supérieur aux limites indiquées. Le débit de l'air et le niveau de bruit doivent être homologués par l'AMCA et le HVI. Tous les appareils doivent être homologués cULus.



Broan-NuTone LLC, 926 West State Street, Hartford, Wisconsin, USA 53027 Broan-NuTone.com 800 558-1711  
 Venmar Ventilation ULC, 550 boul. Lemire, Drummondville, Québec, Canada J2C 7W9 Broan-NuTone.ca 800 567-3855

RÉFÉRENCE	QTÉ	REMARQUES	Projet
			Emplacement
			Architecte
			Ingénieur
			Entrepreneur
			Soumis par <span style="float: right;">Date</span>

# ÉVALUATIONS DE PERFORMANCE - VENTILATEURS À MONTAGE AU PLAFOND COMMERCIAL LÉGER CERTIFIÉS ENERGY STAR® L100E, L150E, L200E, L250E ET L300E

## PERFORMANCES HOMOLOGUÉES PAR L'AMCA

N° DE MODÈLE	PRESSION STATIQUE (pouces d'eau)									TR/MIN NOMINAL	AMPÈRE MAX. @ 60 Hz	VOLTS CA
	0,0	0,1	0,125	0,25	0,375	0,5	0,625	0,75	0,875			
L100E	pi³/min hor.	164	138	132	103	74	40			803	0,3	120
	Sones hor.	0,2	0,3		0,7							
L100E	pi³/min ver.	168	138	131	101	73	38			799	0,3	120
	Sones ver.	0,1	0,2		0,8							
L150E	pi³/min hor.	238	214	209	183	154	122	77		972	0,4	120
	Sones hor.	1,0	1,0		1,1							
L150E	pi³/min ver.	224	203	198	174	146	105	64		990	0,4	120
	Sones ver.	0,9	0,9		1,0							
L200E	pi³/min hor.	267	246	240	214	184	155	109	56	1031	0,5	120
	Sones hor.	1,5	1,5		1,7							
L200E	pi³/min ver.	253	233	228	202	172	123	87	41	1063	0,5	120
	Sones ver.	1,4	1,3		1,5							
L250E	pi³/min hor.	296	277	272	249	223	195	160	108	1128	0,6	120
	Sones hor.	1,9	1,9		1,8							
L250E	pi³/min ver.	280	263	259	237	212	185	142	89	1144	0,6	120
	Sones ver.	1,9	1,8		1,8							
L300E	pi³/min hor.	343	324	319	295	268	237	204	162	1189	0,7	120
	Sones hor.	3,0	2,9		2,7							
L300E	pi³/min ver.	334	315	311	286	258	227	189	150	1207	0,7	120
	Sones ver.	2,9	2,7		2,6							

Les évaluations de performance comprennent l'effet de la grille d'entrée et l'effet du clapet anti reflux sur le débit de l'air. La vitesse (tr/min) indiquée est une valeur nominale. La performance est basée sur la vitesse actuelle obtenue pendant le test. Les évaluations de bruit indiquées ont été testées à 1/3 d'octave dans un champ sphérique libre, d'après la norme 300 de l'AMCA. Les valeurs indiquées sont pour une installation de type B: admission de l'air libre pour le niveau sonore. Les valeurs de performance indiquées sont pour une installation de type B: admission d'air libre, évacuation de l'air avec conduit.

## PERFORMANCE HVI

MODÈLE N°	Conduit	0,1 po Ps			0,25 po Ps	
		pi³/min	Sones	pi³/min/Watt	pi³/min	Sones
L100E	Horizontal	130	0,3	4,9	97	0,8
	Vertical	140	0,3	5,3	101	0,6
L150E	Horizontal	200	1	4,6	168	1,4
	Vertical	210	0,7	4,9	178	1,0
L200E	Horizontal	230	1,3	4,4	198	1,5
	Vertical	240	1	4,6	209	1,3
L250E	Horizontal	270	1,5	4,5	242	2,0
	Vertical	270	1,4	4,5	242	1,5
L300E	Horizontal	310	2,5	4,2	281	2,5
	Vertical	310	2,5	4,3	282	2,5



Broan-Nutone LLC certifie que les modèles décrits ici sont autorisés à porter le sceau de l'AMCA. Les données sont basées sur des essais et méthodes établis par l'AMCA dans la Publication 211 (et la Publication 311 si le niveau de bruit fait également l'objet d'une certification conformément aux exigences du programme de certification des données de l'AMCA.



Tous les modèles sont homologués UL pour utilisation au-dessus de la baignoire et de la douche lorsqu'ils sont raccordés à un circuit protégé par un disjoncteur de fuite à la terre (DDFT) (installation au plafond seulement).

## POIDS

MODÈLE N°	Poids à l'expédition
L100E	18,9 lb
L150E	19,3 lb
L200E	19,1 lb
L250E	21,0 lb
L300E	21,0 lb



L'HOMOLOGATION HVI-2100 est conforme aux nouvelles techniques et procédures d'essai prescrites par le Home Ventilating Institute pour les produits d'emploi courant, dès leur disponibilité pour les consommateurs. Le rendement du produit est évalué à une pression statique de 0,1 po, d'après les tests effectués dans un laboratoire d'essai ultra-perfectionné. Le sone est une mesure de la perception humaine de la puissance sonore, d'après des mesures effectuées en laboratoire.



Broan-NuTone LLC, 926 West State Street, Hartford, Wisconsin, USA 53027 Broan-NuTone.com 800 558-1711  
Venmar Ventilation ULC, 550 boul. Lemire, Drummondville, Québec, Canada J2C 7W9 Broan-NuTone.ca 800 567-3855

# COURBES DE PERFORMANCE - VENTILATEURS À MONTAGE AU PLAFOND COMMERCIAL LÉGER CERTIFIÉS ENERGY STAR®

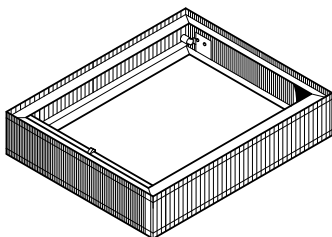
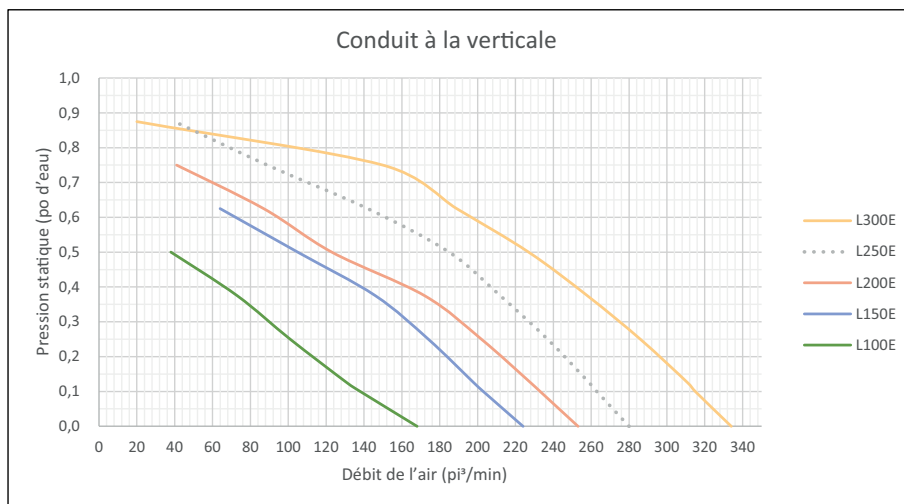
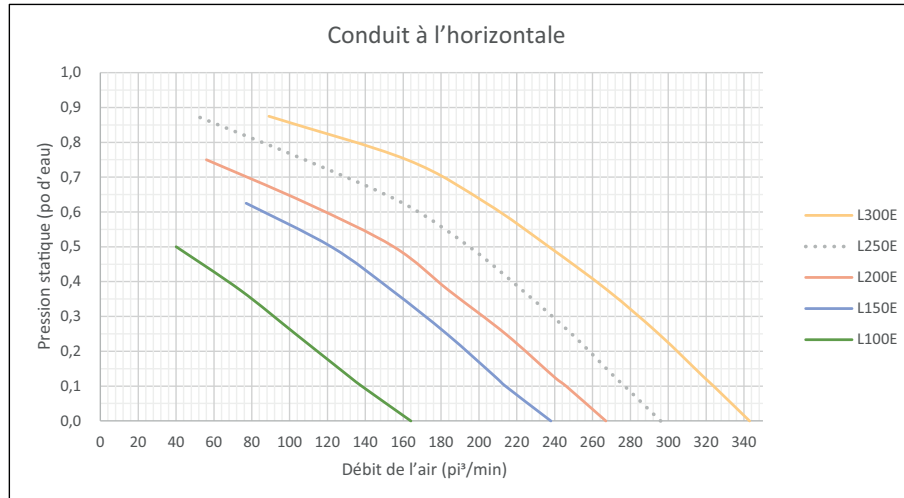

REGISTRÉ COUPE-FEU  
MODÈLE RD1  
(VENDU SÉPARÉMENT)

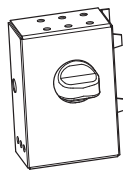

COMMANDE DE VITESSE  
ÉLECTRONIQUE (INTERNE)  
MODÈLE 80L  
(VENDUE SÉPARÉMENT)

RACCORD DE  
CONDUIT DE  
8 PO ROND

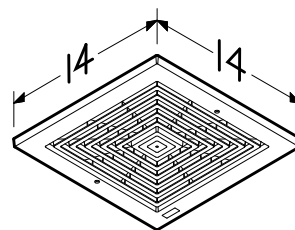
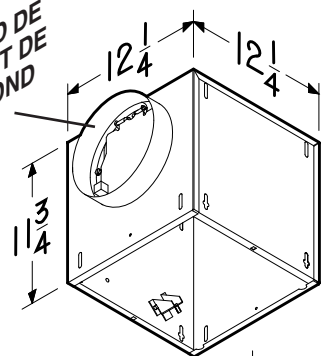

GRILLE DE PLASTIQUE  
(incluse avec  
tous les modèles)

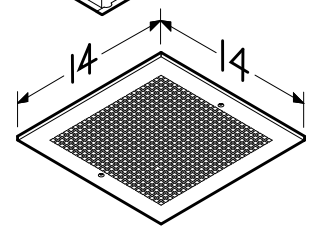

GRILLE DE MÉTAL  
OPTIONNELLE  
MODÈLE MG1  
(vendue séparément)



NOTE : Les dimensions indiquées sont en pouces.



## LOSONE SELECT® CEILING MOUNT VENTILATORS L400, L500, L700 SERIES

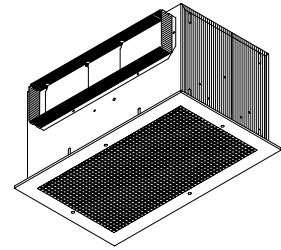

**Incredibly reliable. Unbelievably quiet. Offering the CFM choices you need at the lowest sound levels in the industry.**

### FEATURES

#### GRILLE:

- Conceals interior
- Low profile styling blends with any decor
- Metal, finished with white painted enamel

#### BLOWER:

- Low RPM for quiet operation
- Resilient anti-vibration mounts
- Balanced, polymeric, centrifugal blower wheel for quiet, efficient performance (Models L400K & L500K - metal wheels)
- Permanently lubricated, thermally protected motor
- Plug-in motor rated at 120 VAC
- Designed for continuous operation

#### HOUSING:

- Rugged, 20 gauge galvanized steel
- 4½" x 18½" duct connector
- 1/2" acoustic insulation inside (Models L400K & L500K - no insulation - for kitchen applications)
- May be installed in ceiling or wall (size permitting)
- 8-position mounting brackets for easy installation and greater adaptability to various mounting requirements
- Automatic backdraft damper located within duct connector
- Factory-shipped in horizontal discharge position - easily converted to vertical discharge
- May be installed as an in-line ventilator with addition of accessory kit Model 982L (purchase separately)

#### ACCESSORIES (purchase all separately):

- Model 57V (Ivory) / 57W (White) 3 amp Electronic Variable Speed Control
- Model 59V (Ivory) / 59W (White) 60-Minute Time Control
- Model 61V (Ivory) / 61W (White) 15-Minute Time Control
- Model 80L Electronic Speed Control (Internal)

### TYPICAL SPECIFICATION

Ventilator shall be Broan Model L400, (L400K), (L500), (L500K), (L700).

Ventilator shall have galvanized steel housing insulated with at least 1/2" of acoustic insulation (with no insulation - Models L400K & L500K). Housing to have adjustable mounting brackets.

Automatic backdraft damper to be located within duct connector. Duct connector, blower assembly, and wiring plate shall be adjustable for either horizontal or vertical installation.

Blower unit shall be removable from housing and will have a polymeric (metal - Models L400K & L500K), balanced centrifugal-type blower wheel. Motor to be permanently lubricated and mounted with resilient anti-vibration mounts. RPM not to exceed number listed for each model.

Air delivery shall be no less and sound levels no greater than listed for each model. All air and sound ratings shall be certified by AMCA. Units to be UL and cUL listed.



"Broan-NuTone LLC certifies that the models shown herein are licensed to bear the AMCA Seal. The ratings shown are based on tests and procedures performed in accordance with AMCA Publication 211 (and AMCA Publication 311 if sound is also certified) and comply with the requirements of the AMCA Certified Ratings Program"



**Broan-NuTone LLC**, 926 West State Street, Hartford, Wisconsin 53027 (1-800-637-1453)  
**Broan-NuTone Canada**, 1140 Tristar Drive, Mississauga, Ontario, L5T 1H9 (1-888-882-7626)

REFERENCE	QTY.	REMARKS	Project
			Location
			Architect
			Engineer
			Contractor
			Submitted by <span style="float: right;">Date</span>

# PERFORMANCE RATINGS - LOSONE SELECT® CEILING MOUNT VENTILATORS L400, L500, L700 SERIES

## AMCA LICENSED PERFORMANCE

CFM / SONES - AT STATIC PRESSURES (Ps - inches of H <sub>2</sub> O)															
MODEL NO.	NOMINAL VOLTAGE		0.0" Ps	.10" Ps	.125" Ps	.250" Ps	.375" Ps	.50" Ps	.625" Ps	.750" Ps	.875" Ps	1.0" Ps	NOMINAL RPM	AMPS @60 Hz	WATTS
L400	120 VAC	CFM Hor.	480	442	434	388	344	299	229	182	114	33	735	1.4	146
		SONES Hor.	2.0	2.4	2.3	2.8	3.3	3.8	4.5	4.8	5.4	5.6			
		CFM Ver.	467	428	416	378	335	291	237	170	85	8	755	1.4	146
		SONES Ver.	2.3	2.6	2.6	3.0	3.5	4.0	5.1	5.5	5.7	5.9			
L400K	120 VAC	CFM Hor.	442	415	406	370	330	274	230	191	130	50	675	1.4	146
		SONES Hor.	2.9	3.2	3.3	3.8	4.4	5.3	6.0	6.5	6.8	7.2			
		CFM Ver.	440	409	399	358	294	246	203	157	102	28	680	1.4	146
		SONES Ver.	2.9	3.4	3.3	4.0	5.0	6.1	6.3	6.8	7.1	7.2			
L500	120 VAC	CFM Hor.	538	520	514	491	463	434	389	339	282	186	810	2.2	232
		SONES Hor.	3.0	3.1	3.3	3.6	4.0	4.4	5.0	5.7	6.2	6.7			
		CFM Ver.	539	517	512	481	451	418	367	319	247	137	865	2.2	232
		SONES Ver.	2.9	3.1	3.2	3.4	3.8	4.2	4.8	5.9	6.3	6.4			
L500K	120 VAC	CFM Hor.	506	484	481	460	435	418	389	337	301	231	700	2.2	232
		SONES Hor.	4.3	4.3	4.4	5.0	5.6	6.2	7.0	7.6	8.0	8.3			
		CFM Ver.	481	472	473	443	418	388	353	311	262	187	705	2.2	232
		SONES Ver.	3.6	3.9	4.0	4.5	5.6	6.1	6.7	8.4	8.1	8.6			
L700	120 VAC	CFM Hor.	722	704	701	667	640	607	571	534	453	333	960	2.9	313
		SONES Hor.	4.5	4.6	4.7	4.8	5.0	5.2	5.6	6.2	7.1	7.2			
		CFM Ver.	708	691	687	658	628	597	560	515	444	312	985	2.9	313
		SONES Ver.	5.2	5.0	5.0	5.7	5.8	6.1	6.4	7.4	7.1	7.6			

Performance ratings include the effects of inlet grille and backdraft damper in the airstream. Speed (RPM) shown is nominal. Performance is based on actual speed of test. The sound ratings shown are loudness values in fan sones at 5' (1.5m) in a hemispherical free field calculated per AMCA Std. 301. Values shown are for Installation Type B: Free inlet fan sone levels. Performance shown is for Installation Type B: Free inlet, Ducted outlet.



"Broan-NuTone LLC certifies that the models shown herein are licensed to bear the AMCA Seal. The ratings shown are based on tests and procedures performed in accordance with AMCA Publication 211 (and AMCA Publication 311 if sound is also certified) and comply with the requirements of the AMCA Certified Ratings Program."

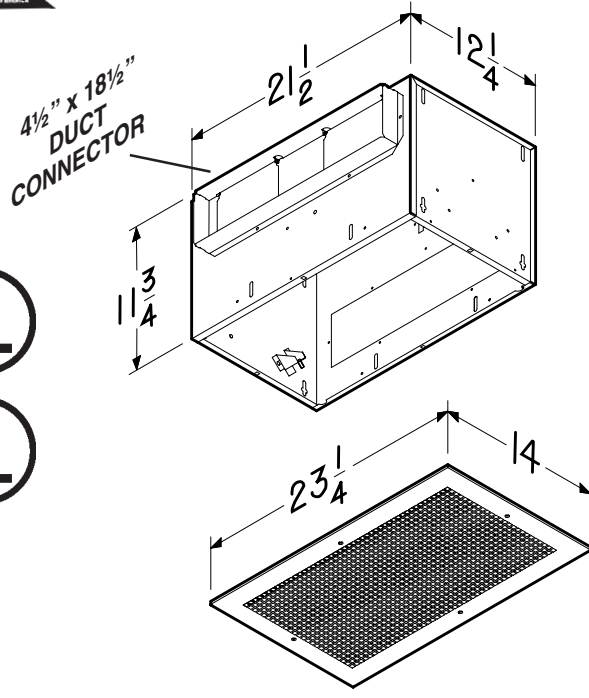
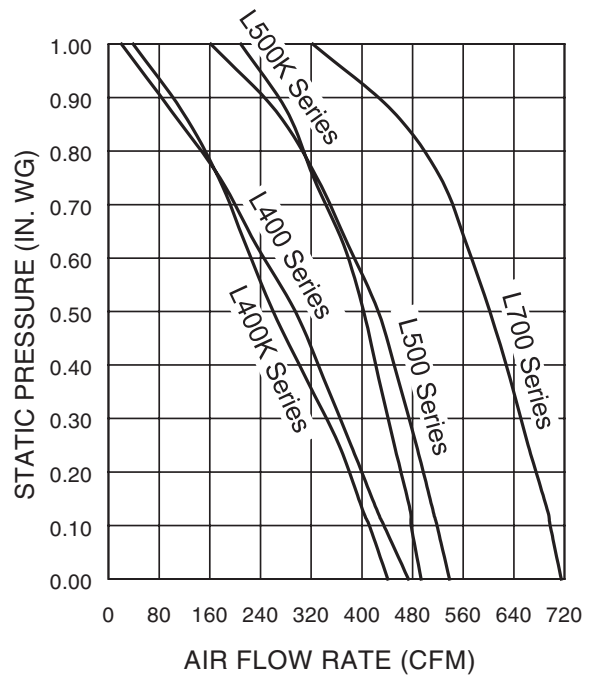

### WEIGHT

MODEL NO.	SHIPPING WT.
L400 L500	33.8 lbs.
L400K, L500K	36.2 lbs.
L700	33.9 lbs.



Broan-NuTone LLC, 926 West State Street, Hartford, Wisconsin 53027 (1-800-637-1453)  
Broan-NuTone Canada, 1140 Tristar Drive, Mississauga, Ontario, L5T 1H9 (1-888-882-7626)