

---

# SUBMITTAL DATA

**Order #:**

**Date:** 03/08/2023

**Project:** 1173 Chicago, IL

**Project #:**

**Date**

03/08/2023

**Project Name**

1173 Chicago, IL

**Project Number**

**Client / Purchaser**

### Submittal Summary Page

Qty	Tag #	Model # / Material #	Description
1	RTU-1	AW15N3DQ2S1CDS62A2	<p>15 Ton, York SunChoice Single Packaged R-410A Air Conditioner, Four Stage Cooling, High Efficiency with variable speed compressor, High Efficiency, Bottom Duct, Natural Gas, Staged Heat, High Heat, 400 MBH Input, 208/230-3-60, 5 kA Standard SCCR, 5 HP High Static Belt Drive Blower</p> <ul style="list-style-type: none"> <li>• IntelliSpeed control of the VFD based on stages of cooling. Provides Single Zone VAV Fan Operation as defined by ASHRAE 90.1 section 6.4.3.10.</li> <li>• Dual Enthalpy Economizer w/Barometric Relief with Economizer Fault Detection &amp; Diagnostic (Meets ASHRAE 90.1-2013, IECC 2015, California Title 24, AMCA 511)</li> <li>• 2" Pleated Filters (MERV 8)</li> <li>• Smart Equipment Controller including Discharge Air, Return Air, and Outdoor Air Temperature Sensors. BACNet MS/TP, Modbus and N2 Communication Card.</li> <li>• HACR Circuit Disconnect</li> <li>• Supply Air Smoke Detector</li> <li>• Phase Monitor</li> <li>• Microchannel condenser coils</li> <li>• Copper tube/Aluminum fin evaporator coils</li> <li>• Modulating Hot Gas Reheat</li> <li>• Head Pressure Control</li> <li>• Standard Cabinet</li> <li>• Polyester SMC Drain Pan</li> </ul>
1	RTU-2	ZT150N24R2B5GCA2R2	<p>12.5 Ton, Single Packaged R-410A Ultra High Efficiency Air Conditioner, Three Stage Cooling, 13.1 EER, 240 MBH Input Aluminized Steel, Two Stage Gas Heat, 208/230-3-60</p> <ul style="list-style-type: none"> <li>• Dry Bulb Low Leak Economizer w/Barometric Relief and Hoods (Bottom or Horizontal End Return Only) with Economizer Fault Detection &amp; Diagnostic (Meets ASHRAE 90.1-2013, IECC 2015, California Title 24, AMCA 511).</li> <li>• VFD Standard</li> <li>• 5 HP High Static Belt Drive Blower</li> <li>• 2" Pleated Filters (MERV 8)</li> <li>• IntelliSpeed control of the VFD based on stages of cooling (Provides Single Zone VAV Fan Operation as defined by ASHRAE 90.1 section 6.4.3.10)</li> <li>• Smart Equipment Controller including Discharge Air, Return Air, and Outdoor Air Temperature Sensors. BACNet MS/TP, Modbus and N2 Communication Card.</li> <li>• Non-Powered Convenience Outlet</li> <li>• HACR Circuit Breaker/Disconnect</li> </ul>

Qty	Tag #	Model # / Material #	Description
			<ul style="list-style-type: none"> <li>• Supply Air Smoke Detector</li> <li>• Phase Monitor</li> <li>• Micro-Channel "all-aluminum" condenser coil, Copper tube/aluminum fin evaporator coil</li> <li>• Composite Drain Pan - Back Connection</li> <li>• Tool-free maintenance with features like hinged doors for all-access panels, slide-out blower and blower motor tray</li> </ul>
1	RTU-2	2AQ04700524	CO <sup>2</sup> Space Sensor - Wall Mount Accessory
1	RTU-2	2EC0402	Kit, Dual Enthalpy Field Installed (Includes two humidity sensors)
2	RTU-3, RTU-5	ZJ037N06D2B5GCA2R4	<p>3 Ton, Single Packaged R-410A Air Conditioner, High Efficiency, Single Stage Cooling, 14.50 SEER / 12.20 EER, 60 MBH Input Aluminized Steel, Two Stage Gas Heat, 208/230-3-60</p> <ul style="list-style-type: none"> <li>• Dry Bulb Low Leak Economizer w/Barometric Relief and Hoods (Bottom or Horizontal End Return Only) with Economizer Fault Detection &amp; Diagnostic (Meets ASHRAE 90.1-2013, IECC 2015, California Title 24, AMCA 511).</li> <li>• 1.5 HP High Static Belt Drive Blower</li> <li>• 2" Pleated Filters (MERV 8)</li> <li>• Smart Equipment Controller including Discharge Air, Return Air, and Outdoor Air Temperature Sensors. BACNet MS/TP, Modbus and N2 Communication Card.</li> <li>• Non-Powered Convenience Outlet</li> <li>• HACR Circuit Breaker/Disconnect</li> <li>• Supply Air Smoke Detector</li> <li>• Phase Monitor</li> <li>• Micro-Channel "all-aluminum" condenser coil, Copper tube/aluminum fin evaporator coil</li> <li>• Composite Drain Pan - Back Connection</li> <li>• Tool-free maintenance with features like hinged doors for all-access panels, slide-out blower and blower motor tray</li> </ul>
2	RTU-3, RTU-5	2AQ04700524	CO <sup>2</sup> Space Sensor - Wall Mount Accessory
2	RTU-3, RTU-5	2EC0402	Kit, Dual Enthalpy Field Installed (Includes two humidity sensors)
1	RTU-4	ZJ049N06D2B5GCA2R3	<p>4 Ton, Single Packaged R-410A Air Conditioner, High Efficiency, Single Stage Cooling, 15.0 SEER / 12.2 EER, 60 MBH Input Aluminized Steel, Two Stage Gas Heat, 208/230-3-60</p> <ul style="list-style-type: none"> <li>• Dry Bulb Low Leak Economizer w/Barometric Relief and Hoods (Bottom or Horizontal End Return Only) with Economizer Fault Detection &amp; Diagnostic (Meets ASHRAE 90.1-2013, IECC 2015, California Title 24, AMCA 511).</li> <li>• 1.5 HP High Static Belt Drive Blower</li> <li>• 2" Pleated Filters (MERV 8)</li> <li>• Smart Equipment Controller including Discharge Air, Return Air, and Outdoor Air Temperature Sensors. BACNet MS/TP, Modbus and N2 Communication Card.</li> <li>• Non-Powered Convenience Outlet</li> <li>• HACR Circuit Breaker/Disconnect</li> <li>• Supply Air Smoke Detector</li> <li>• Phase Monitor</li> </ul>

Qty	Tag #	Model # / Material #	Description
			<ul style="list-style-type: none"> <li>• Micro-Channel "all-aluminum" condenser coil, Copper tube/aluminum fin evaporator coil</li> <li>• Composite Drain Pan - Back Connection</li> <li>• Tool-free maintenance with features like hinged doors for all-access panels, slide-out blower and blower motor tray</li> </ul>
1	RTU-4	2AQ04700524	CO <sup>2</sup> Space Sensor - Wall Mount Accessory
1	RTU-4	2EC0402	Kit, Dual Enthalpy Field Installed (Includes two humidity sensors)
1	UH-1	PV25C1C01B11B30B1G5L 2	STERLING POWER VENTED
1		ADAPTER PACKAGE	AES CURB ADAPTER PACKAGE

Equipment start-up and commissioning by a factory trained technician is recommended.  
Contact your supplying distributor or sales representative for additional information & guidance.



WARNING: Cancer and Reproductive Harm - [www.P65Warnings.ca.gov](http://www.P65Warnings.ca.gov)

## York Single Package R-410A Air Conditioner

Project Name: 1173 Chicago, IL

Unit Model #: AW15N3DQ2S1CDS62A2

Quantity: 1 Tag #: RTU-1

System: AW15N3DQ2S1CDS62A2

### Cooling Performance

Total gross capacity	184.7 MBH
Sensible gross capacity	129.3 MBH
Total net capacity	175.1 MBH
Sensible net capacity	119.7 MBH
Efficiency (at ARI)	12.00 EER
Integrated eff. (at ARI)	20.10 IEER
Ambient DB temp.	75.0 °F
Entering DB temp.	73.1 °F
Entering WB temp.	62.8 °F
Leaving DB temp.	50.3 °F
Leaving WB temp.	50.3 °F
Leaving air temp dew point	50.30 °F
Power input (w/o blower)	10.16 kW
Sound power	89 dB(A)

### Refrigerant

Refrigerant type	R-410A
Sys1	15 lbs
Sys2	14 lbs 8 oz

### Reheat Performance

Total capacity	76.9 MBH
Sensible capacity	0.2 MBH
Ambient DB temp.	85 °F
Entering DB temp.	75 °F
Entering WB temp.	67 °F
Leaving DB temp.	75 °F
Leaving WB temp.	62.8 °F
Power input (w/o blower)	9.60 kW
Gallons of water per hour	8.75 GPM

### Gas Heating Performance

Entering DB temp.	60 °F
Heating output capacity (Max)	324.0 MBH
Supply air	5250 CFM
Heating input capacity (Max)	400 MBH
Leaving DB temp.	117.1 °F
Air temp. rise	57.1 °F
SSE	81.0 %
Stages	2

### Supply Air Blower Performance

Supply air	5250 CFM
Ext. static pressure	1.25 IWG
Addl. Unit Losses (Options/Accessories)	0.13 IWG
Blower speed	1010 HP
Max BHP of Motor (including service factor)	5.75 HP
Duct location	Bottom
Motor rating	5.00 HP
Actual required BHP	3.01 HP
Power input	2.80 kW
Elevation	0 ft.
Drive type	BELT

### Outside/Mixed Air

Outside Air CFM	1050 CFM
Outside Air DB temp.	75 °F
Outside Air WB temp.	65.7 °F
Outside Air RH	47.3 %
Return Air CFM	4200 CFM
Return Air DB temp.	75 °F
Return Air WB temp.	62 °F
Return Air RH	48.1 %

### Electrical Data

Power supply	230-3-60
Unit min circuit ampacity	119.7 Amps
Unit max over-current protection	150 Amps

### Dimensions & Weight

Hgt 57 in.	Len 144 in.	Wth 89 in.
Weight with factory installed options		2625 lbs

### Clearances

Right	42 in.	Front	42 in.	Rear	42 in.
Top	42 in.	Bottom	42 in.	Left	42 in.

Note: Please refer to the tech guide for listed maximum static pressures



### 15 Ton

- Manufactured at an ISO 9001 Registered Facility and Each Rooftop is Completely Computer-Run Tested Prior to Shipment.

### Unit Features

- Four Stage Cooling
- High Efficiency with variable speed compressor
- Full Perimeter Base Rails with Built in Rigging Capabilities
- Dual Enthalpy Economizer w/Barometric Relief with Economizer Fault Detection & Diagnostic (Meets ASHRAE 90.1-2013, IECC 2015, California Title 24, AMCA 511)
- 5 HP High Static Belt Drive Blower
- 2" Pleated Filters (MERV 8)
- Replacement Filters: 6 (20" x 25" x 2" or 4"). Unit accepts 2" or 4" wide filters.
- Units are provided with the selected 2-inch or 4-inch filter and can easily be converted in the field to accept either size in the standard filter rack
- Utility Connections - Gas and electrical utility locations are supplied in the unit underside as well as the side of the unit. Utility connections can be made quickly and with a minimum amount of field labor
- Copper tube/Aluminum fin evaporator coils
- Microchannel condenser coils

### BAS Controller

- Smart Equipment Controller including Discharge Air, Return Air, and Outdoor Air Temperature Sensors. BACNet MS/TP, Modbus and N2 Communication Card.

### Standard Unit Controller: Smart Equipment Control Board

- An Integrated Low-Ambient Control, Anti-Short Cycle Protection, Lead-Lag, Fan On and Fan off Delays, Low Voltage Protection, On-Board Diagnostic and Fault Code Display. Allows all units to operate in the cooling mode down to 0 °F outdoor ambient without additional components or intervention.
- Safety Monitoring - Monitors the High and Low-Pressure Switches, the Freezestats, the Gas Valve, if Applicable, and the Temperature Limit Switch on Gas and Electric Heat Units. The Unit Control Board will Alarm on Ignition Failures, Safety Lockouts and Repeated Limit Switch Trips.

### Warranty

- One (1) Year Limited Warranty on the Complete Unit
- Five (5) Year Warranty - Compressors and Electric Heater Elements
- Ten (10) Year Warranty - Aluminized Steel Tubular Heat Exchangers



# Sun Choice 15-27.5 Ton Package

York Single Package R-410A Air Conditioner

Project Name: 1173 Chicago, IL

Unit Model #: AW15N3DQ2S1CDS62A2

Quantity: 1 Tag #: RTU-1

System: AW15N3DQ2S1CDS62A2





# Sun Choice 15-27.5 Ton Package

York Single Package R-410A Air Conditioner

Project Name: 1173 Chicago, IL

Unit Model #: AW15N3DQ2S1CDS62A2

Quantity: 1 Tag #: RTU-1

System: AW15N3DQ2S1CDS62A2

### Additional Electrical Data

Power supply	230-3-60
Unit min circuit ampacity	119.7 Amps
Unit max over-current protection	150 Amps
Min Voltage	180 V
Max Voltage	254 V
Comp #1 RLA	50.4
Comp #1 LRA	50.4
Comp #2 RLA	26.9
Comp #2 LRA	164
Indoor Mtr Voltage	230-3-60
Indoor Mtr FLA	20.4
Outdoor Mtr Qty	2
Outdoor Fan Voltage	230-1-60
OD Fan Mtr FLA (ea.)	4.7
Power Ex Mtr Qty	2
Powered Ex Voltage	230-1-60
Power Ex Mtr FLA (ea)	5
Combustion Mtr Qty	1
Combustion Motor Voltage	208/230-1-60
Combustion Mtr FLA (ea)	0.8



# Sun Choice 15-27.5 Ton Package

York Single Package R-410A Air Conditioner

Project Name: 1173 Chicago, IL

Unit Model #: AW15N3DQ2S1CDS62A2

Quantity: 1 Tag #: RTU-1

System: AW15N3DQ2S1CDS62A2

## Factory Installed Options

### AW15N3DQ2S1CDS62A2

Equipment Options	Option(s) Selected
Product Category:	<b>A</b> York SunChoice Single Packaged R-410A Air Conditioner
Efficiency:	<b>W</b> High Efficiency, Bottom Duct
Nominal Cooling Capacity:	<b>15</b> 15 Ton
Heat Type:	<b>N</b> Natural Gas, Staged Heat
Heat Size:	<b>3</b> High Heat, 400 MBH Input
Blower Option:	<b>D</b> 5 HP High Static Belt Drive Blower
Air Volume:	<b>Q</b> Four Stage Cooling High Efficiency with variable speed compressor IntelliSpeed control of the VFD based on stages of cooling. Provides Single Zone VAV Fan Operation as defined by ASHRAE 90.1 section 6.4.3.10.
Voltage:	<b>2</b> 208/230-3-60 5 kA Standard SCCR
Outside Air Option:	<b>S</b> Dual Enthalpy Economizer w/Barometric Relief with Economizer Fault Detection & Diagnostic (Meets ASHRAE 90.1-2013, IECC 2015, California Title 24, AMCA 511)
Coil Options:	<b>1</b> Microchannel condenser coils Copper tube/Aluminum fin evaporator coils
Controls:	<b>C</b> Smart Equipment Controller including Discharge Air, Return Air, and Outdoor Air Temperature Sensors. BACNet MS/TP, Modbus and N2 Communication Card.
Sensor Options:	<b>D</b> Supply Air Smoke Detector
Service Options:	<b>S</b> HACR Circuit Disconnect Phase Monitor
Refrigeration:	<b>6</b> Modulating Hot Gas Reheat Head Pressure Control
Additional Options:	<b>2</b> 2" Pleated Filters (MERV 8)
Cabinet Options:	<b>A</b> Standard Cabinet Polyester SMC Drain Pan
Product Generation:	<b>2</b>

## Field Installed Accessories

## York Single Package R-410A Air Conditioner

Project Name: 1173 Chicago, IL

Unit Model #: AW15N3DQ2S1CDS62A2

Quantity: 1 Tag #: RTU-1

System: AW15N3DQ2S1CDS62A2

- |   |  |  |
|---|--|--|
| <ul style="list-style-type: none"> <li><input type="radio"/> 1BD0411 - Burglar Bars</li> <li><input type="radio"/> 1CV0406 - Concentric Diffuser, Flush Mount, 18X36</li> <li><input type="radio"/> 1CV0407 - Concentric Diffuser, Flush Mount, 24X28</li> <li><input type="radio"/> 1CV0415 - Concentric Diffuser, Side Discharge, 18X36</li> <li><input type="radio"/> 1CV0416 - Concentric Diffuser, Side Discharge, 24X48</li> <li><input type="radio"/> 1CV0421 - Concentric Diffuser, Specialty, 28X28</li> <li><input type="radio"/> 1CV0422 - Concentric Diffuser, Specialty, 30X30</li> <li><input type="radio"/> 1CV0423 - Concentric Diffuser, Specialty, 36X36</li> <li><input type="radio"/> 1CV0426 - Concentric Diffuser, Specialty, 24X24</li> <li><input type="radio"/> 1CV0427 - Concentric Diffuser, Specialty, 28X28</li> <li><input type="radio"/> 1CV0428 - Concentric Diffuser, Specialty, 30X30</li> <li><input type="radio"/> 1FE0418 - Flue Exhaust Kit (30.0 lbs)</li> <li><input type="radio"/> 1HA0401 - Natural Gas High Altitude Conversion Kit - For applications between 2000 and 10,000 feet altitude (3.0 lbs)</li> <li><input type="radio"/> 1HA0402 - Propane High Altitude Conversion Kit - For applications between 2000 and 10,000 feet altitude</li> <li><input type="radio"/> 1HG0437 - Louvered Hail Guard, 15 and 17.5 ton models (75.0 lbs)</li> <li><input type="radio"/> 1HG0456 - Louvered Hail Guard, 20 ton (108.0 lbs)</li> <li><input type="radio"/> 1NP0401 - Propane Conversion Kit (4.0 lbs)</li> <li><input type="radio"/> 1RC0443 - 14" Roof Curb (171.0 lbs)</li> <li><input type="radio"/> 1RC0444 - 14" Roof Curb (188.0 lbs)</li> <li><input type="radio"/> 1RC0446 - 24" Roof Curb (237.0 lbs)</li> <li><input type="radio"/> 1RC0447 - 24" Roof Curb (260.0 lbs)</li> <li><input type="radio"/> 1RD0414 - Barometric Relief Damper (40.0 lbs)</li> <li><input type="radio"/> 2AP0402 - Air Proving Switch (1.0 lbs)</li> <li><input type="radio"/> 2AQ04700524 - CO<sup>2</sup> Space Sensor - Wall Mount Accessory (5.0 lbs)</li> <li><input type="radio"/> 2AQ04700624 - CO<sup>2</sup> Unit Mount Accessory (4.6 lbs)</li> <li><input type="radio"/> 2DF0403 - Dirty Filter Switch (1.0 lbs)</li> </ul> | <ul style="list-style-type: none"> <li><input type="radio"/> 2EC0406 - Single Enthalpy / Reheat Humidity Sensor (3.0 lbs)</li> <li><input type="radio"/> 2EC0407 - Dual Enthalpy Sensing (3.0 lbs)</li> <li><input type="radio"/> 2ET077001124 - Honeywell T7350, 2 Heat / 4 Cool, Auto/Man Changeover, Electronic 7 Day Programmable (2.0 lbs)</li> <li><input type="radio"/> 2FS0401 - Condensate Overflow Switch (2.0 lbs)</li> <li><input type="radio"/> 2PE04704925 - Constant Volume Power Exhaust, High CFM, 208/230V, Belt Drive</li> <li><input type="radio"/> 2PE04705025 - "Modulating Power Exhaust, High CFM, 208/230V", Belt Drive</li> <li><input type="radio"/> 2PE04705125 - Modulating Power Exhaust, Standard CFM, 208/230V, Direct Drive</li> <li><input type="radio"/> 2PE04705225 - Constant Volume Power Exhaust, Standard CFM, 208/230V, Direct Drive</li> <li><input type="radio"/> 2SD04703024 - Return Air Smoke Detector (8.0 lbs)</li> <li><input type="radio"/> S1-03102529000 - Non-Networking Wall Sensor – Allows remote sensing and control from single or multiple zones. (0.2 lbs)</li> <li><input type="radio"/> S1-03102529004 - Non-Networking Wall Sensor with Over-ride button – Allows remote sensing and control from single or multiple zones. Override allows setpoint to be overridden for 2 hour time period. (0.2 lbs)</li> <li><input type="radio"/> S1-03102529006 - Non-Networking Wall Sensor with Setpoint Adjustment and Over-ride Button – Allows remote sensing and control from single or multiple zones. Allows setpoint to be adjusted ± 5° F. Override allows setpoint to be overridden for 2 hour time period. (0.2 lbs)</li> <li><input type="radio"/> S1-03103489000 - Temp sensor, 80mm x 80mm, LCD display, screw terminals, adjustable setpoint, JCI logo (0.1 lbs)</li> <li><input type="radio"/> S1-03103490000 - Temp sensor w/Economizer FDD, 120mm x 80mm, LCD display, screw terminals, adjustable setpoint, no logo (0.0 lbs)</li> <li><input type="radio"/> S1-03103516000 - Temp &amp; humidity sensor, 120mm x 80mm, LCD display, screw terminals, warmer/cooler dial, JCI logo (0.4 lbs)</li> </ul> | <ul style="list-style-type: none"> <li><input type="radio"/> S1-03103517000 - Temp sensor, 120mm x 80mm, no display, no dial, screw terminals, no logo (0.4 lbs)</li> <li><input type="radio"/> S1-03103518000 - Temp &amp; humidity sensor, 120mm x 80mm, no display, modular jack, warmer/cooler dial, JCI logo (0.4 lbs)</li> <li><input type="radio"/> S1-03103519000 - Network Sensor ,CO<sub>2</sub>, No Display (0.2 lbs)</li> <li><input type="radio"/> S1-MP-PRTKIT-0P - MAP (Multiple Access Portal) Gateway Kit- Replacement MAP gateway protective case, lanyard and communication cable. Use only to replace worn or damaged components. (0.3 lbs)</li> <li><input type="radio"/> S1-SE-COM1001-0 - Field Installed Communication Card for Simplicity SE control. Can be field configurable for BACnet, N2 or ModBUS MSTP (0.0 lbs)</li> <li><input type="radio"/> S1-YK-MAP1810-0P - MAP (Multiple Access Portal) Gateway- For use with SimplicitySE Control. (0.2 lbs)</li> <li><input type="radio"/> S1-YK-MAP1810-0S - Stationary MAP Gateway (Includes MAP Gateway, Field Bus Adapter, Mounting Bracket and 100 to 240 VAC Power Supply). US-compatible counties. (1.9 lbs)</li> </ul> |
|---|--|--|

Project Name: 1173 Chicago, IL

Unit Model #: AW15N3DQ2S1CDS62A2

Quantity: 1 Tag #: RTU-1

**Consolidated Drawing**

TONNAGE	OPERATING WEIGHT (LBS) (BASE UNIT)	CENTER OF GRAVITY LOCATION (BSAE UNIT)		4 POINT CORNER LOADS (LBS) (BASE UNIT)				6 POINT CORNER LOADS (LBS) (BASE UNIT)					
		X	Y	A	B	C	D	A	B	C	D	E	F
12.5	2190 [993]	67.9 [1726]	46.9 [1191]	610 [277]	547 [248]	488 [221]	545 [247]	415 [188]	358 [162]	319 [145]	370 [168]	385 [175]	343 [156]
15	2240 [1016]	67.5 [1716]	46.4 [1180]	621 [282]	551 [250]	502 [228]	566 [257]	423 [192]	360 [163]	328 [149]	385 [175]	389 [177]	355 [161]

- NOTES:
- FOR OUTDOOR USE ONLY.
  - WEIGHTS SHOWN ARE FOR COOLING ONLY UNITS.
  - SERVICE (S) AND MINIMUM (M) CLEARANCE TO COMBUSTIBLE MATERIAL:
- | UNIT SIDE               | INCHES | MM     |
|-------------------------|--------|--------|
| RIGHT (S)               | 42     | [1067] |
| LEFT, NO ECON OR PE (S) | 18     | [457]  |
| LEFT, W/ ECON OR PE (S) | 96     | [2438] |
| FRONT/HEAT ACCESS (S)   | 80     | [2032] |
| REAR (S)                | 36     | [914]  |
| TOP (S)                 | 120    | [3048] |
| UNIT-TO-UNIT (S)        | 120    | [3048] |
| DUCT (M)                | 0      | [0]    |
| FLOOR (M)               | 0      | [0]    |
| FRONT/FLUE (M)          | 42     | [1067] |
- FOR SMALLER SERVICE AND OPERATIONAL CLEARANCES CONTACT YOUR APPLICATION ENGINEERING DEPARTMENT.
  - DOWNFLOW DUCT DESIGNED TO BE ATTACHED TO ACCESSORY ROOF CURB ONLY. IF UNIT IS MOUNTED SIDE SUPPLY, IT IS RECOMMENDED THAT THE DUCTS ARE SUPPORTED BY CROSS BRACES. AS DONE ON THE ACCESSORY ROOF CURBS.
  - MINIMUM CONDENSATION TRAP HEIGHT SHALL BE 1.5 TIMES THE LOWEST NEGATIVE STATIC.
  - DIMENSION IN [ ] ARE MILLIMETER OR KILOGRAMS.
  - OPTIONAL COIL GUARDS, GAS HEAT, DISCONNECT SWITCH SHOWN.
  - HEAT EXCHANGER IS TYPICAL OF HIGH GAS HEAT OPTION

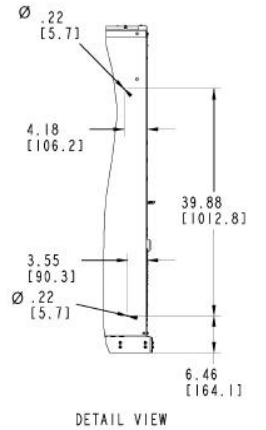
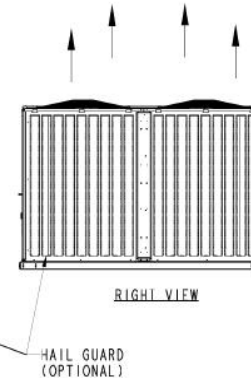
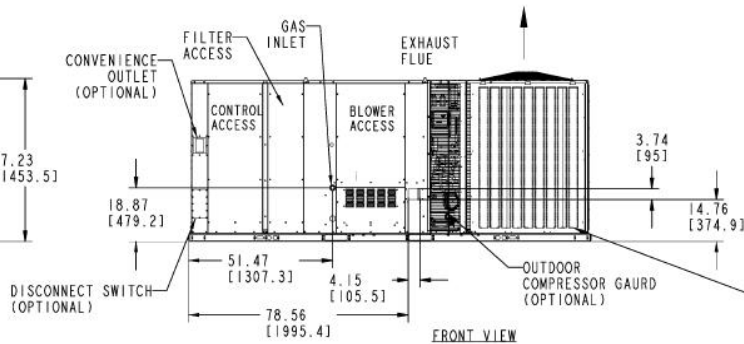
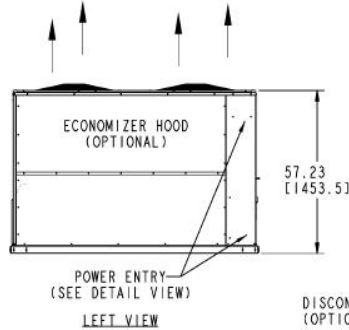
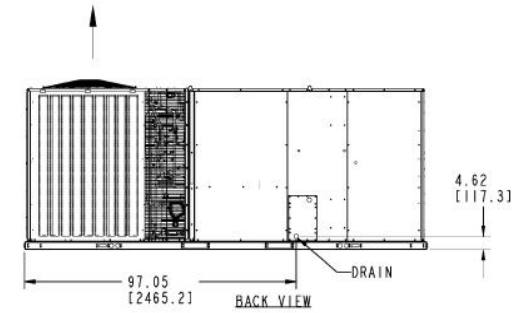
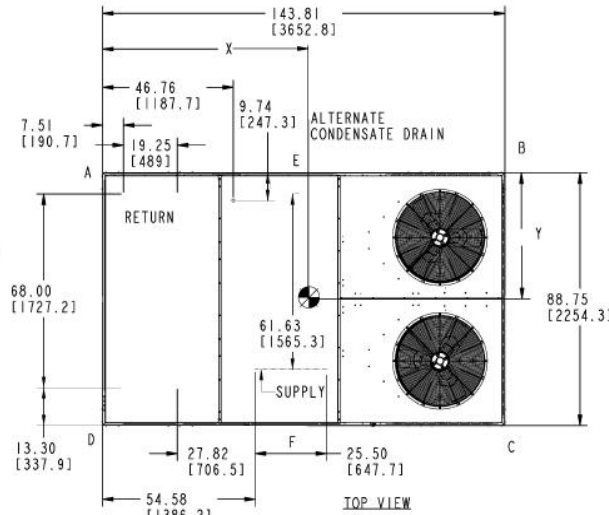

Project Name: 1173 Chicago, IL

Unit Model #: AW15N3DQ2S1CDS62A2

Quantity: 1 Tag #: RTU-1

Component Location

## Unit components

Figure 1: Component location

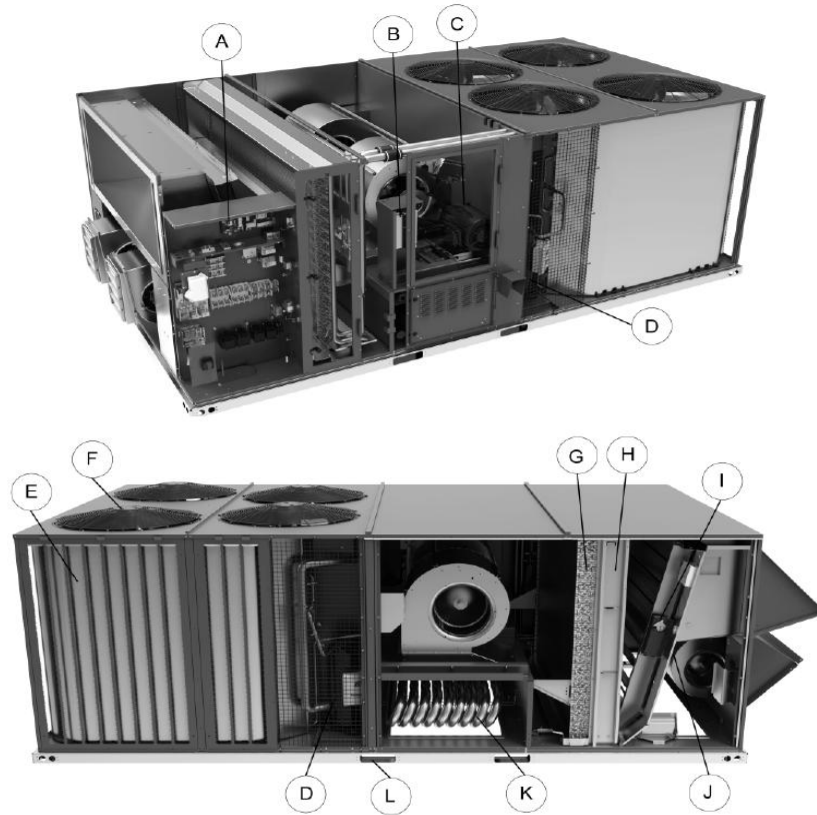

The previous figure shows the AVXX model. The following table lists the components of the unit.

Table 1: Component location table

Item	Description	Item	Description
A	Smart Equipment™ controls	G	Copper tube/aluminum fin evaporator coil
B	Optional variable frequency drive	H	Filter access, 2-inch or 4-inch filter options
C	Belt drive blower motor with dual centrifugal fan design	I	Optional economizer. Optional manual or motorized outside air dampers not shown.
D	Scroll compressors in various arrangements to produce 2 or 4 stages of cooling depending on the selected model	J	Optional powered exhaust. Optional barometric relief not shown.
E	MicroChannel condenser coils	K	Optional staged or modulating gas heat with aluminized or stainless steel heat exchanger
F	Condenser fans	L	Full perimeter base rails with holes for overhead rigging

Project Name: 1173 Chicago, IL

Unit Model #: AW15N3DQ2S1CDS62A2

Quantity: 1 Tag #: RTU-1

### Typical Installation

#### Typical installation

The following figures show the typical installations for the unit.

Figure 14: Roofjack installation

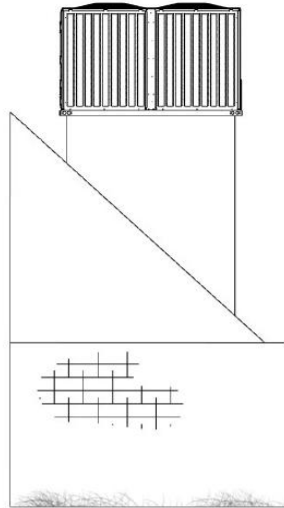
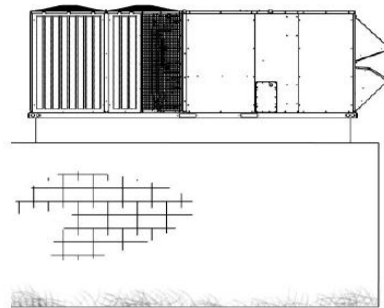

Figure 15: Roof curb installation



Project Name: 1173 Chicago, IL

Unit Model #: AW15N3DQ2S1CDS62A2

Quantity: 1 Tag #: RTU-1

### Economizer Drawing

## Economizer options

Figure 13: Economizer options

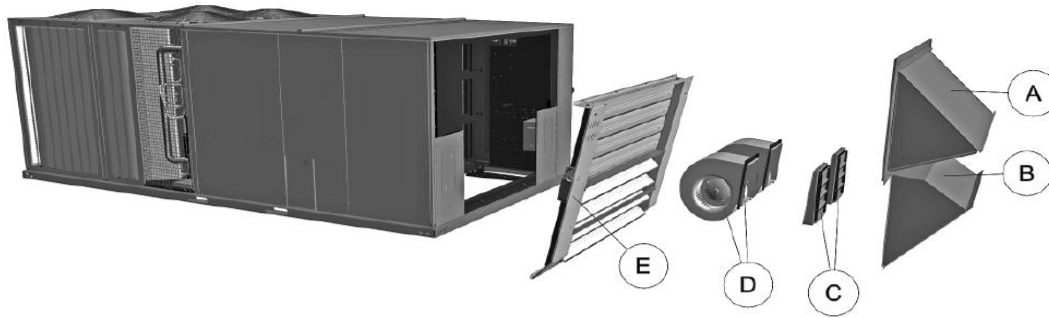

Table 38: Economizer components

Item	Description
A	Fresh air hood
B	Power exhaust hood
C	Power exhaust damper
D	Power exhaust
E	Low leak economizer

Project Name: 1173 Chicago, IL

Unit Model #: AW15N3DQ2S1CDS62A2

Quantity: 1 Tag #: RTU-1

## Rainhood Drawing

### Rain hood dimensions

Figure 8: Rain hood dimensions

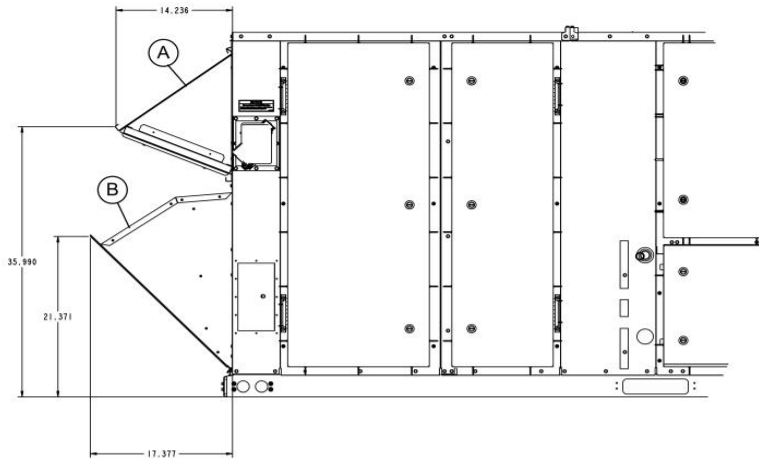

Table 32: Rain hood components

Item	Description
A	Economizer/motorized damper and power exhaust rain hood
B	Air intake hood

## Single Package R-410A Air Conditioner

Project Name: 1173 Chicago, IL

Unit Model #: ZT150N24R2B5GCA2R2

Quantity: 1 Tag #: RTU-2

System: ZT150N24R2B5GCA2R2

### Cooling Performance

Total gross capacity	142.3 MBH
Sensible gross capacity	112.3 MBH
Total net capacity	129.2 MBH
Sensible net capacity	99.2 MBH
Efficiency (at ARI)	12.50 EER
Integrated eff. (at ARI)	20.20 IEER
Ambient DB temp.	95.0 °F
Entering DB temp.	75.0 °F
Entering WB temp.	61.2 °F
Leaving DB temp.	51.2 °F
Leaving WB temp.	49.4 °F
Leaving air temp dew point	47.90 °F
Power input (w/o blower)	9.20 kW
Sound power	83 dB(A)

### Refrigerant

Refrigerant type	R-410A
Sys1	10 lbs 8 oz
Sys2	9 lbs 12 oz

### Gas Heating Performance

Entering DB temp.	60 °F
Heating output capacity (Max)	194.0 MBH
Supply air	4375 CFM
Heating input capacity (Max)	240 MBH
Leaving DB temp.	101.1 °F
Air temp. rise	41.1 °F
SSE	81.0 %
Stages	2

### Supply Air Blower Performance

Supply air	4375 CFM
Ext. static pressure	1.0 IWG
Addl. Unit Losses (Options/Accessories)	0.51 IWG
Blower speed	1310 HP
Max BHP of Motor (including service factor)	5.75 HP
Duct location	Bottom
Motor rating	5.00 HP
Actual required BHP	4.13 HP
Power input	3.85 kW
Elevation	0 ft.
Drive type	BELT
Requires field-supplied drive	true

### Outside/Mixed Air

Outside Air CFM	875 CFM
Outside Air DB temp.	95 °F
Outsided Air WB temp.	65.7 °F
Outside Air RH	19.6 %
Return Air CFM	3500 CFM
Return Air DB temp.	70 °F
Return Air WB temp.	60 °F
Return Air RH	56.1 %

### Electrical Data

Power supply	230-3-60
Unit min circuit ampacity	67.6 Amps
Unit max over-current protection	80 Amps

### Dimensions & Weight

Hgt 51 in.	Len 120 in.	Wth 59 in.
Weight with factory installed options		1683 lbs

### Clearances

Right	12 in.	Front	12 in.	Rear	12 in.
Top	12 in.	Bottom	12 in.	Left	12 in.

Note: Please refer to the tech guide for listed maximum static pressures



### 12.5 Ton

- York Sun Pro units are manufactured at an ISO 9001 registered facility and each rooftop is completely computer-run tested prior to shipment.

### Unit Features

- Three Stage Cooling
- 240 MBH Input Aluminized Steel, Two Stage Gas Heat
- Unit Cabinet Constructed of Powder Painted Steel, Certified At 750 Hours Salt Spray Test (ASTM B-117 Standards)
- Full perimeter base rails with built in rigging capabilities
- Scroll Compressor[s]
- Dry Bulb Low Leak Economizer w/Barometric Relief and Hoods (Bottom or Horizontal End Return Only) with Economizer Fault Detection & Diagnostic (Meets ASHRAE 90.1-2013, IECC 2015, California Title 24, AMCA 511).
- VFD Standard
- Slide-Out Blower/5 HP Belt Drive Motor Assembly
- Unit Ships with 2" Pleated Filters (MERV 8)
- Solid Core Liquid Line Filter Driers
- Replacement Filters: 4 - (24" x 20"). Unit accepts 2" or 4" wide filters.
- Non-Powered Convenience Outlet
- HACR Circuit Breaker/Disconnect
- Single Point Power Connection
- Through-the-Curb and Through-the-Base Utility Connections
- Short Circuit Current: 5kA RMS Symmetrical
- Supply Air Smoke Detector
- Micro-Channel "all-aluminum" condenser coil, Copper tube/aluminum fin evaporator coil
- Crankcase heaters standard
- Composite Drain Pan - Back Connection
- Tool-free maintenance with features like hinged doors for all-access panels, slide-out blower and blower motor tray

### BAS Controller

- IntelliSpeed control of the VFD based on stages of cooling. Provides Single Zone VAV Fan Operation as defined by ASHRAE 90.1 section 6.4.3.10.
- Smart Equipment Controller including Discharge Air, Return Air, and Outdoor Air Temperature Sensors. BACNet MS/TP, Modbus and N2 communication card.

### Standard Unit Controller: Smart Equipment Control Board

- Safety Monitoring - Monitors the High and Low-Pressure Switches, the Freezestats, the Gas Valve, if Applicable, and the Temperature Limit Switch on Gas and Electric Heat Units. The Unit Control Board will Alarm on Ignition Failures, Safety Lockouts and Repeated Limit Switch Trips.

### Warranty

- One (1) Year Limited Warranty on the Complete Unit
- Five (5) Year Warranty - Compressors and Electric Heater Elements
- Ten (10) Year Limited Warranty - Aluminized Steel Heat Exchanger



# York® Sun™ Pro 3-12.5 Ton Package

Single Package R-410A Air Conditioner

Project Name: 1173 Chicago, IL

Unit Model #: ZT150N24R2B5GCA2R2

Quantity: 1 Tag #: RTU-2

System: ZT150N24R2B5GCA2R2

### Additional Electrical Data

Power supply	230-3-60
Unit min circuit ampacity	67.6 Amps
Unit max over-current protection	80 Amps
Min Voltage	187 V
Max Voltage	252 V
Comp #1 RLA	17.6
Comp #1 LRA	136.0
Comp #2 RLA	17.6
Comp #2 LRA	136
Indoor Mtr Voltage	230-3-60
Indoor Mtr FLA	14
Outdoor Mtr Qty	4
Outdoor Fan Voltage	230-1-60
OD Fan Mtr FLA (ea.)	3.5
Power Ex Mtr Qty	1
Powered Ex Voltage	230-1-60
Power Ex Mtr FLA (ea)	5.5
Combustion Mtr Qty	1
Combustion Motor Voltage	208/230-1-60
Combustion Mtr FLA (ea)	0.5



# York® Sun™ Pro 3-12.5 Ton Package

Single Package R-410A Air Conditioner

Project Name: 1173 Chicago, IL

Unit Model #: ZT150N24R2B5GCA2R2

Quantity: 1 Tag #: RTU-2

System: ZT150N24R2B5GCA2R2

## Factory Installed Options

### ZT150N24R2B5GCA2R2

Equipment Options	Option(s) Selected	
Product Category:	<b>ZT</b>	Single Packaged R-410A Ultra High Efficiency Air Conditioner 13.1 EER
Nominal Cooling Capacity:	<b>150</b>	12.5 Ton Three Stage Cooling
Heat Type and Nominal Heat Capacity:	<b>N24</b>	240 MBH Input Aluminized Steel, Two Stage Gas Heat
Blower Option:	<b>R</b>	VFD Standard 5 HP High Static Belt Drive Blower IntelliSpeed control of the VFD based on stages of cooling (Provides Single Zone VAV Fan Operation as defined by ASHRAE 90.1 section 6.4.3.10)
Voltage:	<b>2</b>	208/230-3-60
Outside Air Option:	<b>B</b>	Dry Bulb Low Leak Economizer w/Barometric Relief and Hoods (Bottom or Horizontal End Return Only) with Economizer Fault Detection & Diagnostic (Meets ASHRAE 90.1-2013, IECC 2015, California Title 24, AMCA 511).
Service Options:	<b>5</b>	Non-Powered Convenience Outlet HACR Circuit Breaker/Disconnect
Sensor Options:	<b>G</b>	Supply Air Smoke Detector
Controls:	<b>C</b>	Smart Equipment Controller including Discharge Air, Return Air, and Outdoor Air Temperature Sensors. BACNet MS/TP, Modbus and N2 Communication Card.
Refrigeration:	<b>A</b>	Micro-Channel "all-aluminum" condenser coil, Copper tube/aluminum fin evaporator coil
Additional Options:	<b>2</b>	2" Pleated Filters (MERV 8) Phase Monitor
Cabinet Options:	<b>R</b>	Composite Drain Pan - Back Connection Tool-free maintenance with features like hinged doors for all-access panels, slide-out blower and blower motor tray
Product Generation:	<b>2</b>	

## Field Installed Accessories

1BD0408 - Burglar Bars (32.0 lbs)

1CG0430 - Coil Guard (20.0 lbs)

1CV0404 - Concentric Diffuser, Flush Mount, 18X28



# York® Sun™ Pro 3-12.5 Ton Package

## Single Package R-410A Air Conditioner

Project Name: 1173 Chicago, IL

Unit Model #: ZT150N24R2B5GCA2R2

Quantity: 1 Tag #: RTU-2

System: ZT150N24R2B5GCA2R2

- 1CV0405 - Concentric Diffuser, Flush Mount, 18X32
- 1CV0406 - Concentric Diffuser, Flush Mount, 18X36
- 1CV0413 - Concentric Diffuser, Side Discharge, 18X28
- 1CV0414 - Concentric Diffuser, Side Discharge, 18X32
- 1CV0415 - Concentric Diffuser, Side Discharge, 18X36
- 1CV0420 - Concentric Diffuser, Specialty, 24X24
- 1CV0421 - Concentric Diffuser, Specialty, 28X28
- 1CV0426 - Concentric Diffuser, Specialty, 24X24
- 1FE0412 - Flue Exhaust Extension Kit (14.0 lbs)
- 1FF0414 - 2" Only Metal Filter Frame Kit (16.0 lbs)
- 1HA0425 - High Altitude Kit with Propane Conversion - For applications between 2000 and 6000 feet altitude (1.0 lbs)
- 1HA0448 - High Altitude Kit for Natural Gas - For applications between 2000 and 6000 feet altitude (1.0 lbs)
- 1HG0443 - Double Row Coil Hail Guard Kit- Diamond Pattern (44.0 lbs)
- 1HG0445 - Double Row Coil Hail Guard Kit- Provent Style (30.0 lbs)
- 1NP0463 - Natural Gas to Propane Conversion Kit (2-Stage) (1.0 lbs)
- 1RC0470 - Roof Curb - 8" High, Flat, Uninsulated, Full Perimeter (Shipped Knocked Down) (135.0 lbs)
- 1RC0471 - Roof Curb - 14" High, Flat, Uninsulated, Full Perimeter (Shipped Knocked Down) (135.0 lbs)
- 1RC0472 - Roof Curb, Transition- Sunline 7.5T thru 12.5T to Pro 3.0T thru 12.5T (Shipped Assembled) (200.0 lbs)
- 1RC0476 - Roof Curb - 24" High, Flat, Uninsulated, Full Perimeter (Shipped Knocked Down) (135.0 lbs)
- 2AP0402 - Air Proving Switch (1.0 lbs)
- 2AQ04700524 - CO<sup>2</sup> Space Sensor - Wall Mount Accessory (5.0 lbs)
- 2AQ04700624 - CO<sup>2</sup> Unit Mount Accessory (4.6 lbs)
- 2EC0401 - Kit, Single Enthalpy Field Installed (1.0 lbs)
- 2EC0402 - Kit, Dual Enthalpy Field Installed (Includes two humidity sensors) (1.0 lbs)
- 2ET077001124 - Honeywell T7350, 2 Heat / 4 Cool, Auto/Man Changeover, Electronic 7 Day Programmable (2.0 lbs)
- 2LA04702424 - Low Ambient Kit (3.2 lbs)
- 2PE04704706 - Power Exhaust 230V without Baro Relief Downflow or Horizontal (19.0 lbs)
- 2SD04700924 - Smoke Detector Kit w/ Mounting Hardware for Return Air (Downflow Only) Only (10.0 lbs)
- S1-02812364700 - Blower Sheave for 12.5 Ton High Static Field Installed Drive (3.0 lbs)
- S1-03102529000 - Non-Networking Wall Sensor – Allows remote sensing and control from single or multiple zones. (0.2 lbs)
- S1-03102529004 - Non-Networking Wall Sensor with Over-ride button – Allows remote sensing and control from single or multiple zones. Override allows setpoint to be overridden for 2 hour time period. (0.2 lbs)
- S1-ADDWIRE - Add-a-Wire allows 5-wire thermostats to use only 4 wires. (0.3 lbs)
- S1-CTS DTS - CTS Wired Temperature Sensor for thermostat | Duct \*Also works for LX Series (0.3 lbs)
- S1-CTS HTS - CTS Hardwired Temperature Sensor for CTS Thermostats \*Works with LX series as well (0.2 lbs)
- S1-CTS PLATE - Wall Plate for CTS Thermostats \*Also works for new platform LX series models below (0.0 lbs)
- S1-CTS WFTS - CTS Temperature Sensor with WiFi for CTS Thermostats \*Also works with LX Series (0.1 lbs)
- S1-LX LOCK - Locking Ring For LX-Series Thermostats (0.4 lbs)
- S1-LX PLATE - Wall Plate For LX-Series Thermostats (0.0 lbs)
- S1-LX WFM - For LX Series Thermostats - WiFi Communication (0.1 lbs)
- S1-MP-PRTKIT-0P - MAP (Multiple Access Portal) Gateway Kit- Replacement MAP gateway protective case, lanyard and communication cable. Use only to replace worn or damaged components. (0.3 lbs)
- S1-NSB8BHN041-0 - Wall Temperature and 3% Relative Humidity Combined Sensor, No Display, WHITE, NO JCI LOGO, NS8000 Series (0.4 lbs)
- S1-NSB8BHN043-0 - Wall Temperature and 3% Relative Humidity Combined Sensor, No Display, BLACK, NO JCI LOGO, NS8000 Series (0.4 lbs)
- S1-NSB8BHN141-0 - Wall Temperature and 3% Relative Humidity Combined Sensor, Warmer/Cooler Display, WHITE, NO JCI LOGO, NS8000 Series (0.4 lbs)
- S1-NSB8BHN143-0 - Wall Temperature and 3% Relative Humidity Combined Sensor, Warmer/Cooler Display, BLACK, NO JCI LOGO, NS8000 Series (0.4 lbs)
- S1-NSB8BHN240-0 - Wall Temperature and 3% Relative Humidity Combined Sensor, Full Display, WHITE, JCI LOGO, NS8000 Series (0.4 lbs)
- S1-NSB8BHN241-0 - Wall Temperature and 3% Relative Humidity Combined Sensor, Full Display, WHITE, NO JCI LOGO, NS8000 Series (0.4 lbs)
- S1-NSB8BHN243-0 - Wall Temperature and 3% Relative Humidity Combined Sensor, Full Display, BLACK, NO JCI LOGO, NS8000 Series (0.4 lbs)
- S1-NSB8BPN240-0 - Wall Temperature and 2% Relative Humidity Combined Sensor, Full Display, WHITE, JCI LOGO, NS8000 Series (0.4 lbs)
- S1-NSB8BPN241-0 - Wall Temperature and 2% Relative Humidity Combined Sensor, Full Display, WHITE, NO JCI LOGO, NS8000 Series (0.4 lbs)



# York® Sun™ Pro 3-12.5 Ton Package

## Single Package R-410A Air Conditioner

Project Name: 1173 Chicago, IL

Unit Model #: ZT150N24R2B5GCA2R2

Quantity: 1 Tag #: RTU-2

System: ZT150N24R2B5GCA2R2

- S1-NSB8BPN243-0 - Wall Temperature and 2% Relative Humidity Combined Sensor, Full Display, BLACK, NO JCI LOGO, NS8000 Series (0.4 lbs)
- S1-NSB8BTN041-0 - Wall Temperature Sensor, No Display, WHITE, NO JCI LOGO, NS8000 Series (0.4 lbs)
- S1-NSB8BTN043-0 - Wall Temperature Sensor, No Display, BLACK, NO JCI LOGO, NS8000 Series (0.4 lbs)
- S1-NSB8BTN141-0 - Wall Temperature Sensor, Warmer/Cooler Display, WHITE, NO JCI LOGO, NS8000 Series (0.4 lbs)
- S1-NSB8BTN143-0 - Wall Temperature Sensor, Warmer/Cooler Display, BLACK, NO JCI LOGO, NS8000 Series (0.4 lbs)
- S1-NSB8BTN240-0 - Wall Temperature Sensor, Full Display, WHITE, JCI LOGO, NS8000 Series (0.4 lbs)
- S1-NSB8BTN241-0 - Wall Temperature Sensor, Full Display, WHITE, NO JCI LOGO, NS8000 Series (0.4 lbs)
- S1-NSB8BTN243-0 - Wall Temperature Sensor, Full Display, BLACK, NO JCI LOGO, NS8000 Series (0.4 lbs)
- S1-TEC3030-14-000 - 7 DAY PROGRAMMABLE THERMOSTAT, ZIGBEE PRO WIRELESS COMMUNICATION, RTU/HEAT PUMP WITH ECON, FULL COLOR, WHITE, JCI LOGO (0.8 lbs)
- S1-TEC3030-16-000 - 7 DAY PROGRAMMABLE THERMOSTAT, ZIGBEE PRO WIRELESS COMMUNICATION, RTU/HEAT PUMP WITH ECON, AND FULL COLOR, WHITE, NO LOGO (0.8 lbs)
- S1-TEC3031-14-000 - 7 DAY PROGRAMMABLE THERMOSTAT, ZIGBEE PRO WIRELESS COMMUNICATION, RTU/HEAT PUMP WITH ECON, OCC SENSOR, FULL COLOR, WHITE, JCI LOGO (0.8 lbs)
- S1-TEC3031-16-000 - 7 DAY PROGRAMMABLE THERMOSTAT, ZIGBEE PRO WIRELESS COMMUNICATION, RTU/HEAT PUMP WITH ECON, OCC SENSOR, FULL COLOR, WHITE, NO LOGO (0.8 lbs)
- S1-TEC3630-14-000 - 7 DAY PROGRAMMABLE THERMOSTAT, OPTIONAL MSTP OR N2 COMMUNICATION, RTU/HEAT PUMP WITH ECON, FULL COLOR, WHITE, JCI LOGO (0.8 lbs)
- S1-TEC3631-14-000 - 7 DAY PROGRAMMABLE THERMOSTAT, OPTIONAL MSTP OR N2 COMMUNICATION, RTU/HEAT PUMP WITH ECON, OCC SENSOR, FULL COLOR, WHITE, JCI LOGO (0.8 lbs)
- S1-TEC3631-16-000 - 7 DAY PROGRAMMABLE THERMOSTAT, OPTIONAL MSTP OR N2 COMMUNICATION, RTU/HEAT PUMP WITH ECON, OCC SENSOR, FULL COLOR, WHITE, NO LOGO (0.8 lbs)
- S1-YK/AN-RSO-ACI - Non-Networking Wall Sensor with Setpoint Adjustment and Over-ride Button – Allows remote sensing and control from single or multiple zones. (1.0 lbs)
- S1-YK-MAP1810-0P - MAP (Multiple Access Portal) Gateway- For use with SimplicitySE Control. (0.2 lbs)
- S1-YK-MAP1810-0S - Stationary MAP Gateway (Includes MAP Gateway, Field Bus Adapter, Mounting Bracket and 100 to 240 VAC Power Supply). US-compatible counties. (1.9 lbs)

Project Name: 1173 Chicago, IL

Unit Model #: ZT150N24R2B5GCA2R2

Quantity: 1 Tag #: RTU-2

### Consolidated Drawing

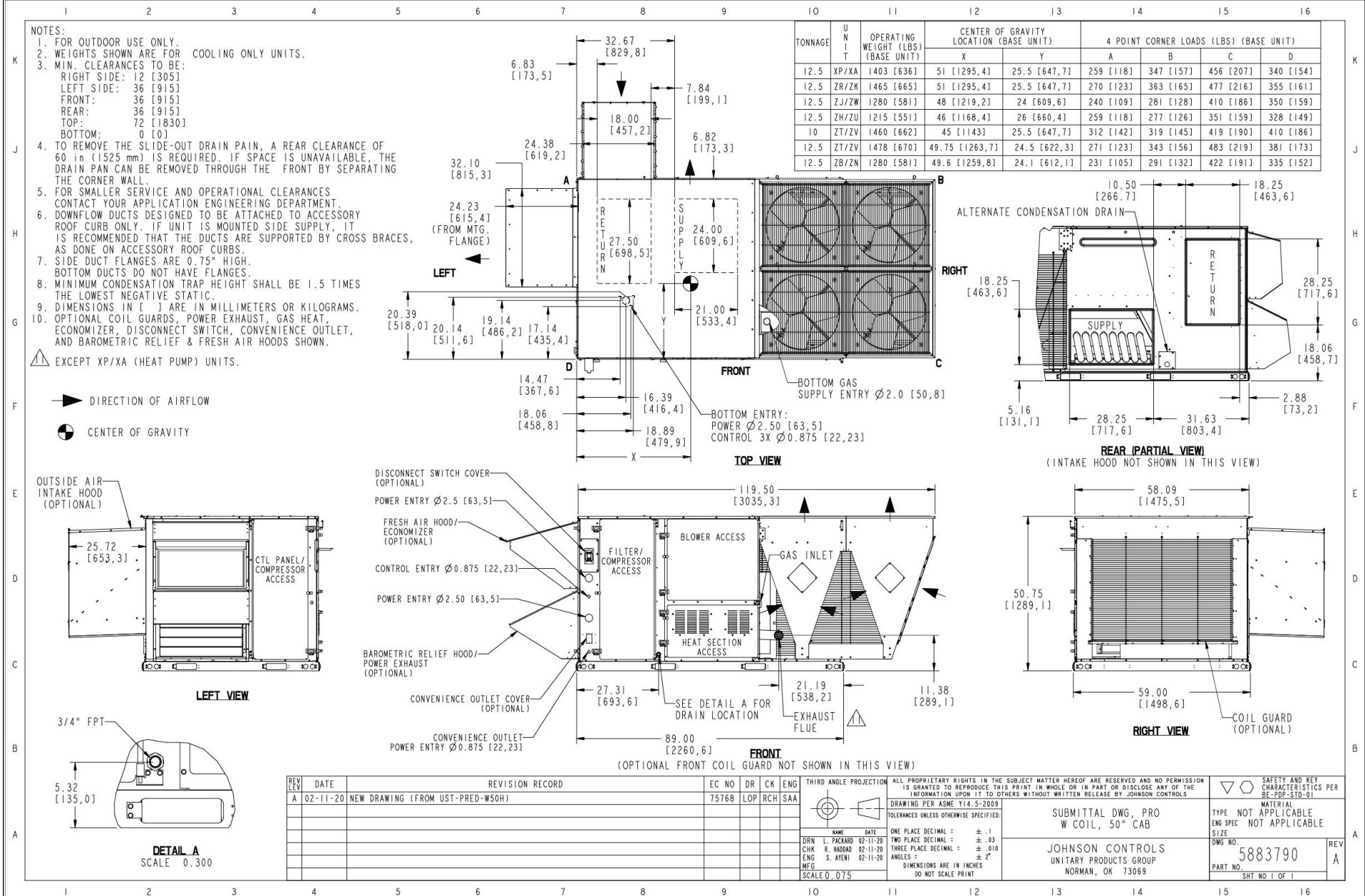

### Low Leak Downflow Economizer

### Low Leak Downflow Economizer (shown with optional Power Exhaust)

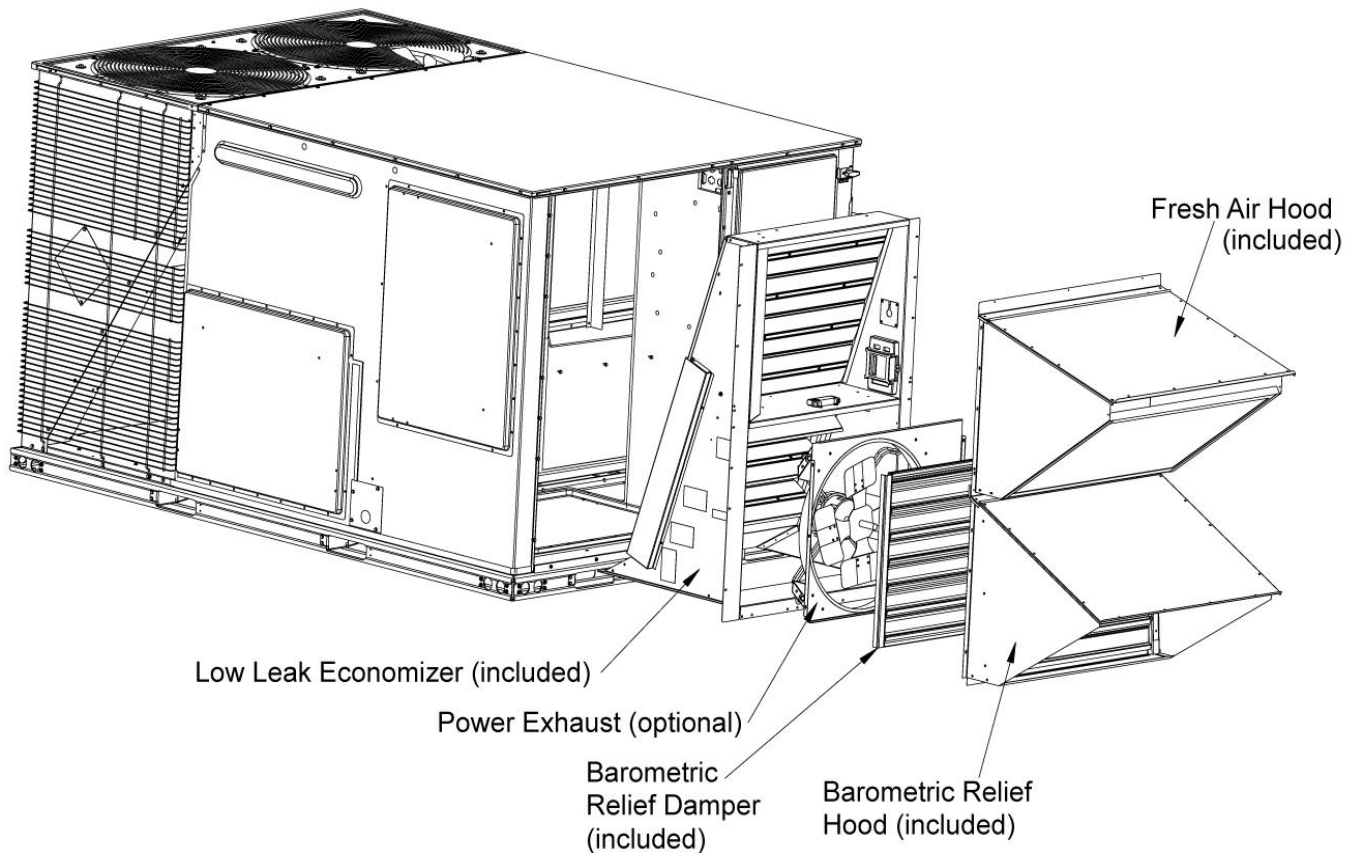

Low leak economizers are capable achieving low leakage rates of 3 cfm/sq. ft at 1" of static pressure, meeting or exceeding the following standards:

- ASHRAE 90.1-2010
- ASHRAE 62
- AMCA 511 (licensed as Class 1A damper)
- International Energy Conservation Code (IECC)
- California Title 24

The outdoor intake opening shall be covered with a rain hood that matches the exterior of the unit. Water eliminator/filters shall be provided.

Simultaneous economizer/compressor operation is also possible. Dampers shall fully close on power loss.

## Single Package R-410A Air Conditioner

Project Name: 1173 Chicago, IL

Unit Model #: ZT150N24R2B5GCA2R2

Quantity: 1 Tag #: RTU-2

### Seismic Certification



## OFFICE OF STATEWIDE HEALTH PLANNING AND DEVELOPMENT FACILITIES DEVELOPMENT DIVISION

### APPLICATION FOR OSHPD SPECIAL SEISMIC CERTIFICATION PREAPPROVAL (OSP)

OFFICE USE ONLY

APPLICATION #: OSP - 0213

#### OSHPD Special Seismic Certification Preapproval (OSP)

Type:  New  Renewal

#### Manufacturer Information

Manufacturer: Johnson Controls Inc. (JCI)

Manufacturer's Technical Representative: Cameron Boyce, Engineer II

Mailing Address: 5005 Interstate Drive, Norman, OK, 73069

Telephone: (405) 419-6830

Email: [cameron.w.boyce@jci.com](mailto:cameron.w.boyce@jci.com)

#### Product Information

Product Name: Predator Rooftop Air Conditioning Units

Product Type: Packaged Air Conditioning Units OSP-0213

Product Model Number: See attached

(List all unique product identification numbers and/or part numbers)

The units are enclosures with the following subcomponents: refrigerant compressors, outdoor fan motors, indoor coils, outdoor coils, reversing valve with coil, thermostatic expansion valves, standard indoor blower motor, Variable frequency drive indoor blower motor, exhaust fan motor, variable frequency drive, economizer, electric heater, heat cells, filters, and other miscellaneous items included in the subcomponent tables.

Mounting Description: Units are rigid curb and isolated curb base mounted

#### Applicant Information

Applicant Company Name: The VMC Group

Contact Person: John Giuliano

Mailing Address: 113 Main Street, Bloomingdale, NJ 07403

Telephone: (973) 838-1780

Email: [john.giuliano@thevmcgroup.com](mailto:john.giuliano@thevmcgroup.com)

I hereby agree to reimburse the Office of Statewide Health Planning and Development review fees in accordance with the California Administrative Code, 2016.

Signature of Applicant: 

Date: 8/28/19

Title: President

Company Name: The VMC Group

"Access to Safe, Quality Healthcare Environments that Meet California's Diverse

STATE OF CALIFORNIA - HEALTH AND HUMAN SERVICES AGENCY  
OSH-FD-759 (REV 12/16/15)

Page 1 of 3

## Single Package R-410A Air Conditioner

Project Name: 1173 Chicago, IL

Unit Model #: ZT150N24R2B5GCA2R2

Quantity: 1 Tag #: RTU-2

### Seismic Certification



## OFFICE OF STATEWIDE HEALTH PLANNING AND DEVELOPMENT FACILITIES DEVELOPMENT DIVISION

### California Licensed Structural Engineer Responsible for the Engineering and Test Report(s)

Company Name: The VMC GroupName: Kenneth Tarlow California License Number: SE-2851Mailing Address: 113 Main Street, Bloomingdale, NJ 07403Telephone: (973) 838-1780 Email: [ken.tarlow@thevmcgroup.com](mailto:ken.tarlow@thevmcgroup.com)

### Supports and Attachments Preapproval

- Supports and attachments are preapproved under OPM- \_\_\_\_\_  
(Separate application for OSHPD Preapproval of Manufacturer's Certification (OPM) of Supports and attachments is required)
- Supports and attachments are not preapproved

### Certification Method

- Testing in accordance with:  ICC-ES AC156
- Other (Please Specify): \_\_\_\_\_

BY: Timothy J PilandDATE: 03/08/2021

### Testing Laboratory

Company Name: DCL LabsContact Name: Josh Sailer, Laboratory ManagerMailing Address: 1315 Greg Street, Suite 109, Sparks, NV 89431Telephone: (775) 358-5085 Email: [josh@shaketest.com](mailto:josh@shaketest.com)

"Access to Safe, Quality Healthcare Environments that Meet California's Diverse

STATE OF CALIFORNIA – HEALTH AND HUMAN SERVICES AGENCY  
OSH-FD-759 (REV 12/16/15)

Page 2 of 3

## Single Package R-410A Air Conditioner

Project Name: 1173 Chicago, IL

Unit Model #: ZT150N24R2B5GCA2R2

Quantity: 1 Tag #: RTU-2

### Seismic Certification



## OFFICE OF STATEWIDE HEALTH PLANNING AND DEVELOPMENT FACILITIES DEVELOPMENT DIVISION

### Seismic Parameters

Design in accordance with ASCE 7-16 Chapter 13:  Yes  No

Design Basis of Equipment or Components ( $F_p/W_p$ ) = Rigid Curb = 1.5; Spring Isolated Curb = 4.5

$S_{DS}$  (Design spectral response acceleration at short period, g) = 2.00

$a_p$  (In-structure equipment or component amplification factor) = 2.5

$R_p$  (Equipment or component response modification factor) = Rigid Curb = 6.0; Spring Isolated Curb = 2.0

$\Omega_0$  (System overstrength factor) = 2.0

$I_p$  (Importance factor) = 1.5

$z/h$  (Height factor ratio) = 1

Equipment or Component Natural Frequencies (Hz) = See attachment

Overall dimensions and weight (or range thereof) = See attachment

Equipment or Components @ grade designed in accordance with ASCE 7-16 Chapter 15:  Yes  No

Design Basis of Equipment or Components ( $V/W$ ) =

$S_{DS}$  (Design spectral response acceleration at short period, g) =

$S_{D1}$  (Design spectral response acceleration at 1 second period, g) =

$R$  (Response modification coefficient) =

$\Omega_0$  (System overstrength factor) =

$C_d$  (Deflection amplification factor) =

$I_p$  (Importance factor) = 1.5

Height to Center of Gravity above base =

Equipment or Component Natural Frequencies (Hz) =

Overall dimensions and weight (or range thereof) =

Tank(s) designed in accordance with ASME BPVC, 2015:  Yes  No

### List of Attachments Supporting Special Seismic Certification

Test Report(s)  Drawings  Calculations  Manufacturer's Catalog

Other(s) (Please Specify):

### OSHPD Approval (For Office Use Only) – Approval Expires on December 31, 2025

Signature:  Date: March 8, 2021

Print Name: Timothy J. Piland Title: SSE

Special Seismic Certification Valid Up to:  $S_{DS}$  (g) = 2.00  $z/h$  = 1

Condition of Approval (if applicable):

"Access to Safe, Quality Healthcare Environments that Meet California's Diverse

STATE OF CALIFORNIA – HEALTH AND HUMAN SERVICES AGENCY  
OSH-FD-759 (REV 12/16/15)

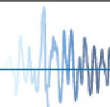

## Single Package R-410A Air Conditioner

Project Name: **1173 Chicago, IL**

Unit Model #: **ZT150N24R2B5GCA2R2**

Quantity: **1** Tag #: **RTU-2**

### Seismic Certification

**Table 1 - Certified Components**

Manufacturer: Johnson Controls and other Unitary Product Group brands (York, Coleman, Luxaire, Evcon, Fraser-Johnston and Ready Ship)

Product Line: JCI Packaged Rooftop Units

Product Construction: Cabinets constructed of G90 galvanized 1,000 hour salt spray (per ASTM-B117) rated powder-coated 20 gage carbon steel wrapper and duct panel with integral corner posts, all attached at the base to four (4) full perimeter 14 gage base rails with #10 sheet metal screws.

Options: 230-575 V, economizer, power exhaust, electric or gas heater, variable frequency drive

Mounting Description: Rigid or Flexible Curb Mounting

Product Line	Model Number <sup>2</sup>	Dimensions (inches)			Operating Weight (lb)	Nominal Cooling Capacity (Tons)	Sds (g), z/h=1	Unit
		Depth	Width	Height				
Predator Air Handling Units (Short)	ZH/ZU/JA3 037	89	59	42	860 <sup>1</sup>	3	2.0	3
	ZJ/ZW/JA3 037	89	59	42	740	3		Interpolated
	ZR/ZK/JA3 037	89	59	42	980 <sup>1</sup>	3		1
	ZT/ZV/JA3 037	89	59	42	922	3		Interpolated
	ZH/ZU/JA4 049	89	59	42	763	4		Interpolated
	ZJ/ZW/JA4 049	89	59	42	762	4		Interpolated
	ZR/ZK/JA4 049	89	59	42	880	4		Interpolated
	ZT/ZV/JA4 049	89	59	42	960	4		Interpolated
	ZH/ZU/JA5 061	89	59	42	772	5		Interpolated
	ZJ/ZW/JA5 061	89	59	42	1,070 <sup>1</sup>	5		4
	ZR/ZK/JA5 061	89	59	42	1,070 <sup>1</sup>	5		2
	ZT/ZV/JA5 061	89	59	42	968	5		Extrapolated
Predator Air Handling Units (Standard)	XP/XA/J06 078	89	59	42	970 <sup>1</sup>	6.5	2.0	7
	ZF/ZS/J06 078	89	59	42	1,090 <sup>1</sup>	6.5		10
	ZH/ZU/J06 078	89	59	42	910	6.5		Interpolated
	ZJ/ZW/J06 078	89	59	51	1030	6.5		Interpolated
	ZR/ZK/J06 078	89	59	51	1,060 <sup>1</sup>	6.5		5
	ZF/ZS/J07 090	89	59	42	860	7.5		Interpolated
	ZH/ZU/J07 090	89	59	42	910	7.5		Interpolated
	ZJ/ZW/J07 090	89	59	51	1,081	7.5		Interpolated
	XP/XA/J07 090	89	59	42	920	7.5		Interpolated
	ZR/ZK/J07 090	89	59	42	965	7.5		Interpolated
	ZF/ZS/J08 102	89	59	51	1,020	8.5		Interpolated
	ZH/ZU/J08 102	89	59	51	1,030	8.5		Interpolated
	ZJ/ZW/J08 102	89	59	51	1,060	8.5		Interpolated
	XP/XA/J08 102	89	59	51	1,135	8.5		Interpolated
	ZR/ZK/J08 102	89	59	51	1,200	8.5		Interpolated
	ZF/ZS/J10 120	89	59	51	1,060	10		Interpolated
	ZH/ZU/J10 120	89	59	51	1,090	10		Interpolated
	ZJ/ZW/J10 120	89	59	51	1,070	10		Interpolated
	XP/XA/J10 120	89	59	51	1,135	10		Interpolated
	ZR/ZK/J10 120	89	59	51	1,200	10		Interpolated
	ZF/ZS/J12 150	119.5	59	51	1,253	12.5		Interpolated
	ZH/ZU/J12 150	119.5	59	51	1,250 <sup>1</sup>	12.5		11
	XP/XA/J12 150	119.5	59	51	1,510 <sup>1</sup>	12.5		8
	ZJ/ZW/J12 150	119.5	59	51	1,570 <sup>1</sup>	12.5		9
ZR/ZK/J12 150	119.5	59	51	1,600 <sup>1</sup>	12.5	6		
Predator Air Handling Units (Ultra High Efficiency)	ZT/ZV 120	119.5	59	51	1,470 <sup>1</sup>	10	2.0	12
	ZT/ZV 078	119.5	59	51	1,550	6.5		Interpolated
	ZT/ZV 090	119.5	59	51	1,550	7.5		Interpolated
	ZT/ZV 102	119.5	59	51	1,575	8.5		Interpolated
	ZT/ZV 150	119.5	59	51	1,680 <sup>1</sup>	12.5		13

1. Weights listed for tested units are actual, not approximate weights. The weights listed for interpolated units are maximum weights, assuming all optional features are included. Optional features are summarized in the table below.

2. Model numbers are generalized for each type of unit and the associated BTU tonnage that the unit can output.

Unit Accessory	Operating Weight (lbs.)
Economizer	85
Power Exhaust	35
Electric Heat	49
Gas Heat	110
Variable Frequency Drive	30

1. Weight given is for the maximum electric heater size available.

2. Weight given for the gas heater is for the maximum number of tube heat exchangers available (8 tube).

3. Weight includes mounting hardware, controls and manual bypass option.

## Single Package R-410A Air Conditioner

Project Name: 1173 Chicago, IL

Unit Model #: ZJ037N06D2B5GCA2R4

Quantity: 2 Tag #: RTU-3, RTU-5

System: ZJ037N06D2B5GCA2R4

### Cooling Performance

Total gross capacity	35.3 MBH
Sensible gross capacity	27.8 MBH
Total net capacity	33.3 MBH
Sensible net capacity	25.8 MBH
Seasonal Efficiency (at ARI)	14.50 SEER
Efficiency (at ARI)	12.20 EER
Ambient DB temp.	95.0 °F
Entering DB temp.	75.0 °F
Entering WB temp.	59.1 °F
Leaving DB temp.	50.4 °F
Leaving WB temp.	46.2 °F
Leaving air temp dew point	42.20 °F
Power input (w/o blower)	2.30 kW
Sound power	72 dB(A)

### Refrigerant

Refrigerant type	R-410A
Sys1	6 lbs 8 oz

### Gas Heating Performance

Entering DB temp.	60 °F
Heating output capacity (Max)	49.0 MBH
Supply air	1050 CFM
Heating input capacity (Max)	60 MBH
Leaving DB temp.	103.2 °F
Air temp. rise	43.2 °F
SSE	81.0 %
Stages	2

### Supply Air Blower Performance

Supply air	1050 CFM
Ext. static pressure	1.0 IWG
Add. Unit Losses (Options/Accessories)	-0.05 IWG
Blower speed	875 HP
Max BHP of Motor (including service factor)	1.50 HP
Duct location	Bottom
Motor rating	1.50 HP
Actual required BHP	0.62 HP
Power input	0.57 kW
Elevation	0 ft.
Drive type	BELT

### Outside/Mixed Air

Outside Air CFM	210 CFM
Outside Air DB temp.	95 °F
Outsided Air WB temp.	55 °F
Outside Air RH	.6 %
Return Air CFM	840 CFM
Return Air DB temp.	70 °F
Return Air WB temp.	60 °F
Return Air RH	56.1 %

### Electrical Data

Power supply	230-3-60
Unit min circuit ampacity	18.4 Amps
Unit max over-current protection	25 Amps

### Dimensions & Weight

Hgt 42 in.	Len 89 in.	Wth 59 in.
Weight with factory installed options 975 lbs		

### Clearances

Right	12 in.	Front	12 in.	Rear	12 in.
Top	12 in.	Bottom	12 in.	Left	12 in.

Note: Please refer to the tech guide for listed maximum static pressures



### 3 Ton

- York Sun Pro units are manufactured at an ISO 9001 registered facility and each rooftop is completely computer-run tested prior to shipment.

### Unit Features

- Single Stage Cooling
- 60 MBH Input Aluminized Steel, Two Stage Gas Heat
- Unit Cabinet Constructed of Powder Painted Steel, Certified At 750 Hours Salt Spray Test (ASTM B-117 Standards)
- Full perimeter base rails with built in rigging capabilities
- Dry Bulb Low Leak Economizer w/Barometric Relief and Hoods (Bottom or Horizontal End Return Only) with Economizer Fault Detection & Diagnostic (Meets ASHRAE 90.1-2013, IECC 2015, California Title 24, AMCA 511).
- Slide-Out Blower/1.5 HP Belt Drive Motor Assembly
- Unit Ships with 2" Pleated Filters (MERV 8)
- Solid Core Liquid Line Filter Driers
- Replacement Filters: 4 - (24" x 16"). Unit accepts 2" or 4" wide filters.
- Non-Powered Convenience Outlet
- HACR Circuit Breaker/Disconnect
- Short Circuit Current: 5kA RMS Symmetrical
- Single Point Power Connection
- Through-the-Curb and Through-the-Base Utility Connections
- Supply Air Smoke Detector
- Micro-Channel "all-aluminum" condenser coil, Copper tube/aluminum fin evaporator coil
- Composite Drain Pan - Back Connection
- Tool-free maintenance with features like hinged doors for all-access panels, slide-out blower and blower motor tray

### Standard Unit Controller: Smart Equipment Control Board

- Safety Monitoring - Monitors the High and Low-Pressure Switches, the Freezestats, the Gas Valve, if Applicable, and the Temperature Limit Switch on Gas and Electric Heat Units. The Unit Control Board will Alarm on Ignition Failures, Safety Lockouts and Repeated Limit Switch Trips.

### Warranty

- One (1) Year Limited Warranty on the Complete Unit
- Five (5) Year Warranty - Compressors and Electric Heater Elements
- Ten (10) Year Limited Warranty - Aluminized Steel Heat Exchanger



# York® Sun™ Pro 3-12.5 Ton Package

Single Package R-410A Air Conditioner

Project Name: 1173 Chicago, IL

Unit Model #: ZJ037N06D2B5GCA2R4

Quantity: 2 Tag #: RTU-3, RTU-5

System: ZJ037N06D2B5GCA2R4

### Additional Electrical Data

Power supply	230-3-60
Unit min circuit ampacity	18.4 Amps
Unit max over-current protection	25 Amps
Min Voltage	187 V
Max Voltage	252 V
Comp #1 RLA	9.2
Comp #1 LRA	70.0
Indoor Mtr Voltage	230-3-60
Indoor Mtr FLA	5.2
Outdoor Mtr Qty	1
Outdoor Fan Voltage	230-1-60
OD Fan Mtr FLA (ea.)	1.65
Power Ex Mtr Qty	1
Powered Ex Voltage	230-1-60
Power Ex Mtr FLA (ea)	5.5
Combustion Mtr Qty	1
Combustion Motor Voltage	208/230-1-60
Combustion Mtr FLA (ea)	0.5



# York® Sun™ Pro 3-12.5 Ton Package

Single Package R-410A Air Conditioner

Project Name: 1173 Chicago, IL

Unit Model #: ZJ037N06D2B5GCA2R4

Quantity: 2 Tag #: RTU-3, RTU-5

System: ZJ037N06D2B5GCA2R4

## Factory Installed Options

### ZJ037N06D2B5GCA2R4

Equipment Options	Option(s) Selected
Product Category:	<b>ZJ</b> Single Packaged R-410A Air Conditioner, High Efficiency 14.50 SEER / 12.20 EER
Nominal Cooling Capacity:	<b>037</b> 3 Ton Single Stage Cooling
Heat Type and Nominal Heat Capacity:	<b>N06</b> 60 MBH Input Aluminized Steel, Two Stage Gas Heat
Blower Option:	<b>D</b> 1.5 HP High Static Belt Drive Blower
Voltage:	<b>2</b> 208/230-3-60
Outside Air Option:	<b>B</b> Dry Bulb Low Leak Economizer w/Barometric Relief and Hoods (Bottom or Horizontal End Return Only) with Economizer Fault Detection & Diagnostic (Meets ASHRAE 90.1-2013, IECC 2015, California Title 24, AMCA 511).
Service Options:	<b>5</b> Non-Powered Convenience Outlet HACR Circuit Breaker/Disconnect
Sensor Options:	<b>G</b> Supply Air Smoke Detector
Controls:	<b>C</b> Smart Equipment Controller including Discharge Air, Return Air, and Outdoor Air Temperature Sensors. BACNet MS/TP, Modbus and N2 Communication Card.
Refrigeration:	<b>A</b> Micro-Channel "all-aluminum" condenser coil, Copper tube/aluminum fin evaporator coil
Additional Options:	<b>2</b> 2" Pleated Filters (MERV 8) Phase Monitor
Cabinet Options:	<b>R</b> Composite Drain Pan - Back Connection Tool-free maintenance with features like hinged doors for all-access panels, slide-out blower and blower motor tray
Product Generation:	<b>4</b>

## Field Installed Accessories

- 1BD0408 - Burglar Bars (32.0 lbs)
- 1CG0428 - Coil Guard (20.0 lbs)
- 1CV0402 - Concentric Diffuser, Flush Mount, 18RD
- 1CV0411 - Concentric Diffuser, Side Discharge, 18RD (55.0 lbs)
- 1CV0419 - Concentric Diffuser, Specialty, 18X18
- 1FE0412 - Flue Exhaust Extension Kit (14.0 lbs)
- 1FF0415 - 2" Only metal Filter Frame Kit (16.0 lbs)
- 1HA0424 - High Altitude Kit with Propane Conversion - For applications between 2000 and 6000 feet altitude (1.0 lbs)



# York® Sun™ Pro 3-12.5 Ton Package

## Single Package R-410A Air Conditioner

Project Name: 1173 Chicago, IL

Unit Model #: ZJ037N06D2B5GCA2R4

Quantity: 2 Tag #: RTU-3, RTU-5

System: ZJ037N06D2B5GCA2R4

- 1HA0447 - High Altitude Kit for Natural Gas - For applications between 2000 and 6000 feet altitude (1.0 lbs)
- 1HG0415 - Hail Guard Kit-Diamond Pattern (50.0 lbs)
- 1HG0431 - Hail Guard Kit-Provent Style (20.0 lbs)
- 1NP0462 - Natural Gas to Propane Conversion Kit (1.0 lbs)
- 1RC0470 - Roof Curb - 8" High, Flat, Uninsulated, Full Perimeter (Shipped Knocked Down) (135.0 lbs)
- 1RC0471 - Roof Curb - 14" High, Flat, Uninsulated, Full Perimeter (Shipped Knocked Down) (135.0 lbs)
- 1RC0476 - Roof Curb - 24" High, Flat, Uninsulated, Full Perimeter (Shipped Knocked Down) (135.0 lbs)
- 1WC0412 - Wooden Crate (445.0 lbs)
- 2AP0402 - Air Proving Switch (1.0 lbs)
- 2AQ04700524 - CO<sup>2</sup> Space Sensor - Wall Mount Accessory (5.0 lbs)
- 2AQ04700624 - CO<sup>2</sup> Unit Mount Accessory (4.6 lbs)
- 2EC0401 - Kit, Single Enthalpy Field Installed (1.0 lbs)
- 2EC0402 - Kit, Dual Enthalpy Field Installed (Includes two humidity sensors) (1.0 lbs)
- 2LA04702412 - Low Ambient Kit - ICM 333 (2.2 lbs)
- 2PE04704706 - Power Exhaust 230V without Baro Relief Downflow or Horizontal (19.0 lbs)
- 2SD04700924 - Smoke Detector Kit w/ Mounting Hardware for Return Air (Downflow Only) Only (10.0 lbs)
- S1-02812384700 - Blower Sheave AK54 High Static Field Installed Drive (2.0 lbs)
- S1-03102529000 - Non-Networking Wall Sensor – Allows remote sensing and control from single or multiple zones. (0.2 lbs)
- S1-03102529004 - Non-Networking Wall Sensor with Over-ride button – Allows remote sensing and control from single or multiple zones. Override allows setpoint to be overridden for 2 hour time period. (0.2 lbs)
- S1-ADDWIRE - Add-a-Wire allows 5-wire thermostats to use only 4 wires. (0.3 lbs)
- S1-CTSDTS - CTS Wired Temperature Sensor for thermostat | Duct \*Also works for LX Series (0.3 lbs)
- S1-CTSHTS - CTS Hardwired Temperature Sensor for CTS Thermostats \*Works with LX series as well (0.2 lbs)
- S1-CTSPLATE - Wall Plate for CTS Thermostats \*Also works for new platform LX series models below (0.0 lbs)
- S1-CTSWFTS - CTS Temperature Sensor with WiFi for CTS Thermostats \*Also works with LX Series (0.1 lbs)
- S1-LXLOCK - Locking Ring For LX-Series Thermostats (0.4 lbs)
- S1-LXPLATE - Wall Plate For LX-Series Thermostats (0.0 lbs)
- S1-LXWFM - For LX Series Thermostats - WiFi Communication (0.1 lbs)
- S1-MP-PRTKIT-0P - MAP (Multiple Access Portal) Gateway Kit- Replacement MAP gateway protective case, lanyard and communication cable. Use only to replace worn or damaged components. (0.3 lbs)
- S1-NSB8BHN041-0 - Wall Temperature and 3% Relative Humidity Combined Sensor, No Display, WHITE, NO JCI LOGO, NS8000 Series (0.4 lbs)
- S1-NSB8BHN043-0 - Wall Temperature and 3% Relative Humidity Combined Sensor, No Display, BLACK, NO JCI LOGO, NS8000 Series (0.4 lbs)
- S1-NSB8BHN141-0 - Wall Temperature and 3% Relative Humidity Combined Sensor, Warmer/Cooler Display, WHITE, NO JCI LOGO, NS8000 Series (0.4 lbs)
- S1-NSB8BHN143-0 - Wall Temperature and 3% Relative Humidity Combined Sensor, Warmer/Cooler Display, BLACK, NO JCI LOGO, NS8000 Series (0.4 lbs)
- S1-NSB8BHN240-0 - Wall Temperature and 3% Relative Humidity Combined Sensor, Full Display, WHITE, JCI LOGO, NS8000 Series (0.4 lbs)
- S1-NSB8BHN241-0 - Wall Temperature and 3% Relative Humidity Combined Sensor, Full Display, WHITE, NO JCI LOGO, NS8000 Series (0.4 lbs)
- S1-NSB8BHN243-0 - Wall Temperature and 3% Relative Humidity Combined Sensor, Full Display, BLACK, NO JCI LOGO, NS8000 Series (0.4 lbs)
- S1-NSB8BPN240-0 - Wall Temperature and 2% Relative Humidity Combined Sensor, Full Display, WHITE, JCI LOGO, NS8000 Series (0.4 lbs)
- S1-NSB8BPN241-0 - Wall Temperature and 2% Relative Humidity Combined Sensor, Full Display, WHITE, NO JCI LOGO, NS8000 Series (0.4 lbs)
- S1-NSB8BPN243-0 - Wall Temperature and 2% Relative Humidity Combined Sensor, Full Display, BLACK, NO JCI LOGO, NS8000 Series (0.4 lbs)
- S1-NSB8BTN041-0 - Wall Temperature Sensor, No Display, WHITE, NO JCI LOGO, NS8000 Series (0.4 lbs)
- S1-NSB8BTN043-0 - Wall Temperature Sensor, No Display, BLACK, NO JCI LOGO, NS8000 Series (0.4 lbs)
- S1-NSB8BTN141-0 - Wall Temperature Sensor, Warmer/Cooler Display, WHITE, NO JCI LOGO, NS8000 Series (0.4 lbs)
- S1-NSB8BTN143-0 - Wall Temperature Sensor, Warmer/Cooler Display, BLACK, NO JCI LOGO, NS8000 Series (0.4 lbs)
- S1-NSB8BTN240-0 - Wall Temperature Sensor, Full Display, WHITE, JCI LOGO, NS8000 Series (0.4 lbs)



# York® Sun™ Pro 3-12.5 Ton Package

## Single Package R-410A Air Conditioner

Project Name: 1173 Chicago, IL

Unit Model #: ZJ037N06D2B5GCA2R4

Quantity: 2 Tag #: RTU-3, RTU-5

System: ZJ037N06D2B5GCA2R4

- S1-NSB8BTN241-0 - Wall Temperature Sensor, Full Display, WHITE, NO JCI LOGO, NS8000 Series (0.4 lbs)
- S1-NSB8BTN243-0 - Wall Temperature Sensor, Full Display, BLACK, NO JCI LOGO, NS8000 Series (0.4 lbs)
- S1-TEC3030-14-000 - 7 DAY PROGRAMMABLE THERMOSTAT, ZIGBEE PRO WIRELESS COMMUNICATION, RTU/HEAT PUMP WITH ECON, FULL COLOR, WHITE, JCI LOGO (0.8 lbs)
- S1-TEC3030-16-000 - 7 DAY PROGRAMMABLE THERMOSTAT, ZIGBEE PRO WIRELESS COMMUNICATION, RTU/HEAT PUMP WITH ECON, AND FULL COLOR, WHITE, NO LOGO (0.8 lbs)
- S1-TEC3031-14-000 - 7 DAY PROGRAMMABLE THERMOSTAT, ZIGBEE PRO WIRELESS COMMUNICATION, RTU/HEAT PUMP WITH ECON, OCC SENSOR, FULL COLOR, WHITE, JCI LOGO (0.8 lbs)
- S1-TEC3031-16-000 - 7 DAY PROGRAMMABLE THERMOSTAT, ZIGBEE PRO WIRELESS COMMUNICATION, RTU/HEAT PUMP WITH ECON, OCC SENSOR, FULL COLOR, WHITE, NO LOGO (0.8 lbs)
- S1-TEC3630-14-000 - 7 DAY PROGRAMMABLE THERMOSTAT, OPTIONAL MSTP OR N2 COMMUNICATION, RTU/HEAT PUMP WITH ECON, FULL COLOR, WHITE, JCI LOGO (0.8 lbs)
- S1-TEC3630-16-000 - 7 DAY PROGRAMMABLE THERMOSTAT, OPTIONAL MSTP OR N2 COMMUNICATION, RTU/HEAT PUMP WITH ECON, FULL COLOR, WHITE, NO LOGO (0.8 lbs)
- S1-TEC3631-14-000 - 7 DAY PROGRAMMABLE THERMOSTAT, OPTIONAL MSTP OR N2 COMMUNICATION, RTU/HEAT PUMP WITH ECON, OCC SENSOR, FULL COLOR, WHITE, JCI LOGO (0.8 lbs)
- S1-TEC3631-16-000 - 7 DAY PROGRAMMABLE THERMOSTAT, OPTIONAL MSTP OR N2 COMMUNICATION, RTU/HEAT PUMP WITH ECON, OCC SENSOR, FULL COLOR, WHITE, NO LOGO (0.8 lbs)
- S1-YK/AN-RSO-ACI - Non-Networking Wall Sensor with Setpoint Adjustment and Over-ride Button – Allows remote sensing and control from single or multiple zones. (1.0 lbs)
- S1-YK-MAP1810-0P - MAP (Multiple Access Portal) Gateway- For use with SimplicitySE Control. (0.2 lbs)
- S1-YK-MAP1810-0S - Stationary MAP Gateway (Includes MAP Gateway, Field Bus Adapter, Mounting Bracket and 100 to 240 VAC Power Supply). US-compatible counties. (1.9 lbs)



Project Name: 1173 Chicago, IL

Unit Model #: ZJ037N06D2B5GCA2R4

Quantity: 2 Tag #: RTU-3, RTU-5

### Component Locations

#### Component Location

##### Cooling With Gas Heat (3 Through 5 Ton)

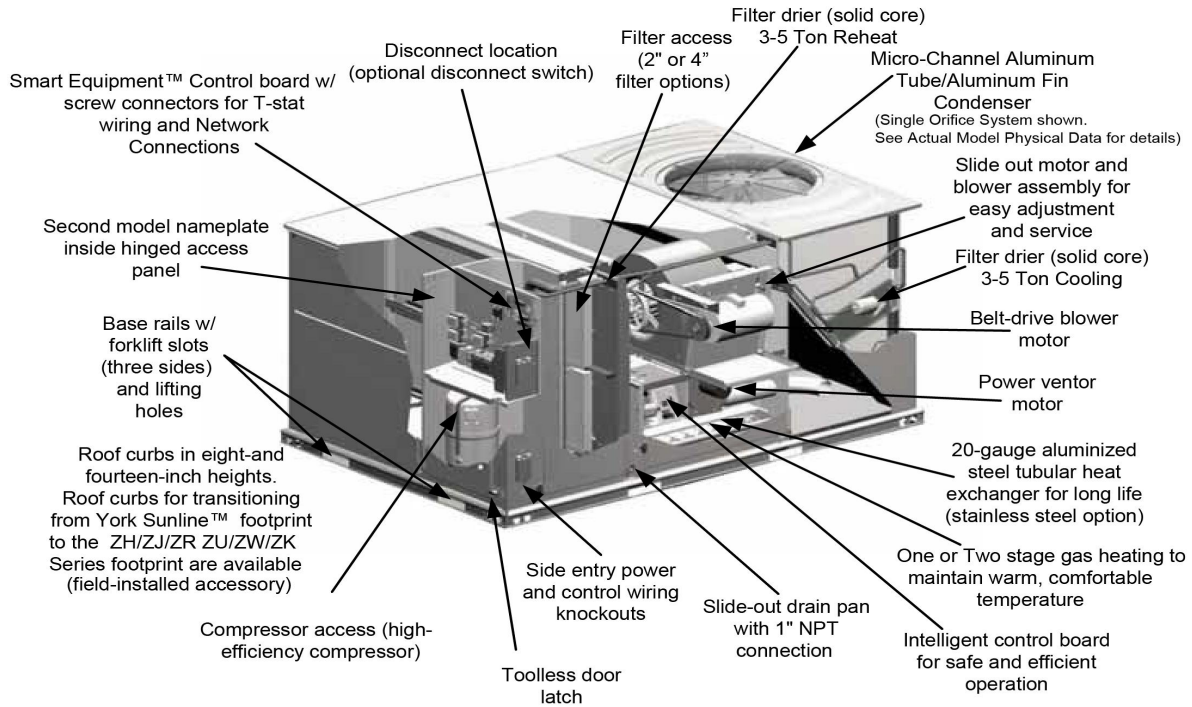

### Low Leak Downflow Economizer

### Low Leak Downflow Economizer (shown with optional Power Exhaust)

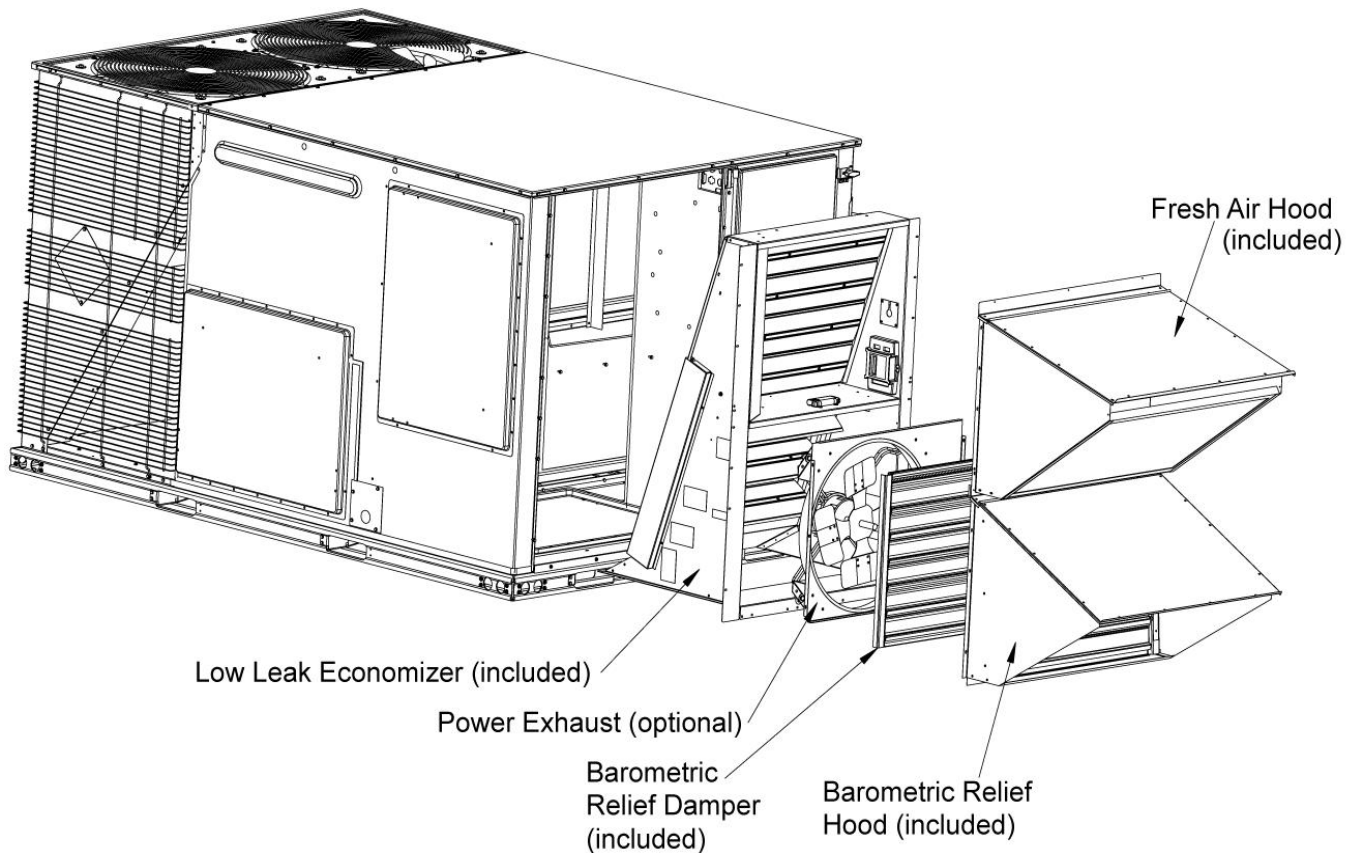

Low leak economizers are capable achieving low leakage rates of 3 cfm/sq. ft at 1" of static pressure, meeting or exceeding the following standards:

- ASHRAE 90.1-2010
- ASHRAE 62
- AMCA 511 (licensed as Class 1A damper)
- International Energy Conservation Code (IECC)
- California Title 24

The outdoor intake opening shall be covered with a rain hood that matches the exterior of the unit. Water eliminator/filters shall be provided.

Simultaneous economizer/compressor operation is also possible. Dampers shall fully close on power loss.

## Single Package R-410A Air Conditioner

Project Name: 1173 Chicago, IL

Unit Model #: ZJ037N06D2B5GCA2R4

Quantity: 2 Tag #: RTU-3, RTU-5

### Seismic Certification



## OFFICE OF STATEWIDE HEALTH PLANNING AND DEVELOPMENT FACILITIES DEVELOPMENT DIVISION

### APPLICATION FOR OSHPD SPECIAL SEISMIC CERTIFICATION PREAPPROVAL (OSP)

OFFICE USE ONLY

APPLICATION #: OSP - 0213

#### OSHPD Special Seismic Certification Preapproval (OSP)

Type:  New  Renewal

#### Manufacturer Information

Manufacturer: Johnson Controls Inc. (JCI)

Manufacturer's Technical Representative: Cameron Boyce, Engineer II

Mailing Address: 5005 Interstate Drive, Norman, OK, 73069

Telephone: (405) 419-6830

Email: [cameron.w.boyce@jci.com](mailto:cameron.w.boyce@jci.com)

#### Product Information

Product Name: Predator Rooftop Air Conditioning Units

Product Type: Packaged Air Conditioning Units OSP-0213

Product Model Number: See attached

(List all unique product identification numbers and/or part numbers)

The units are enclosures with the following subcomponents: refrigerant compressors, outdoor fan motors, indoor coils, outdoor coils, reversing valve with coil, thermostatic expansion valves, standard indoor blower motor, Variable frequency drive indoor blower motor, exhaust fan motor, variable frequency drive, economizer, electric heater, heat cells, filters, and other miscellaneous items included in the subcomponent tables.

Mounting Description: Units are rigid curb and isolated curb base mounted

#### Applicant Information

Applicant Company Name: The VMC Group

Contact Person: John Giuliano

Mailing Address: 113 Main Street, Bloomingdale, NJ 07403

Telephone: (973) 838-1780

Email: [john.giuliano@thevmcgroup.com](mailto:john.giuliano@thevmcgroup.com)

I hereby agree to reimburse the Office of Statewide Health Planning and Development review fees in accordance with the California Administrative Code, 2016.

Signature of Applicant: 

Date: 8/28/19

Title: President

Company Name: The VMC Group

"Access to Safe, Quality Healthcare Environments that Meet California's Diverse

STATE OF CALIFORNIA – HEALTH AND HUMAN SERVICES AGENCY  
OSH-FD-759 (REV 12/16/15)

Page 1 of 3

## Single Package R-410A Air Conditioner

Project Name: 1173 Chicago, IL

Unit Model #: ZJ037N06D2B5GCA2R4

Quantity: 2 Tag #: RTU-3, RTU-5

### Seismic Certification



## OFFICE OF STATEWIDE HEALTH PLANNING AND DEVELOPMENT FACILITIES DEVELOPMENT DIVISION

### California Licensed Structural Engineer Responsible for the Engineering and Test Report(s)

Company Name: The VMC GroupName: Kenneth TarlowCalifornia License Number: SE-2851Mailing Address: 113 Main Street, Bloomingdale, NJ 07403Telephone: (973) 838-1780Email: [ken.tarlow@thevmcgroup.com](mailto:ken.tarlow@thevmcgroup.com)

### Supports and Attachments Preapproval

- Supports and attachments are preapproved under OPM- \_\_\_\_\_  
(Separate application for OSHPD Preapproval of Manufacturer's Certification (OPM) of Supports and attachments is required)
- Supports and attachments are not preapproved

### Certification Method

- Testing in accordance with:  ICC-ES AC156
- Other (Please Specify): \_\_\_\_\_

### Testing Laboratory

Company Name: DCL LabsContact Name: Josh Sailer, Laboratory ManagerMailing Address: 1315 Greg Street, Suite 109, Sparks, NV 89431Telephone: (775) 358-5085Email: [josh@shaketest.com](mailto:josh@shaketest.com)

"Access to Safe, Quality Healthcare Environments that Meet California's Diverse

STATE OF CALIFORNIA – HEALTH AND HUMAN SERVICES AGENCY  
OSH-FD-759 (REV 12/16/15)



Page 2 of 3

## Single Package R-410A Air Conditioner

Project Name: 1173 Chicago, IL

Unit Model #: ZJ037N06D2B5GCA2R4

Quantity: 2 Tag #: RTU-3, RTU-5

### Seismic Certification



## OFFICE OF STATEWIDE HEALTH PLANNING AND DEVELOPMENT FACILITIES DEVELOPMENT DIVISION

### Seismic Parameters

Design in accordance with ASCE 7-16 Chapter 13:  Yes  NoDesign Basis of Equipment or Components ( $F_p/W_p$ ) = Rigid Curb = 1.5; Spring Isolated Curb = 4.5 $S_{DS}$  (Design spectral response acceleration at short period, g) = 2.00 $a_p$  (In-structure equipment or component amplification factor) = 2.5 $R_p$  (Equipment or component response modification factor) = Rigid Curb = 6.0; Spring Isolated Curb = 2.0 $\Omega_0$  (System overstrength factor) = 2.0 $I_p$  (Importance factor) = 1.5 $z/h$  (Height factor ratio) = 1

Equipment or Component Natural Frequencies (Hz) = See attachment

Overall dimensions and weight (or range thereof) = See attachment

Equipment or Components @ grade designed in accordance with ASCE 7-16 Chapter 15:  Yes  NoDesign Basis of Equipment or Components ( $V/W$ ) = $S_{DS}$  (Design spectral response acceleration at short period, g) = $S_{D1}$  (Design spectral response acceleration at 1 second period, g) = $R$  (Response modification coefficient) = $\Omega_0$  (System overstrength factor) = $C_d$  (Deflection amplification factor) = $I_p$  (Importance factor) = 1.5

Height to Center of Gravity above base =

Equipment or Component Natural Frequencies (Hz) =

Overall dimensions and weight (or range thereof) =

Tank(s) designed in accordance with ASME BPVC, 2015:  Yes  No

### List of Attachments Supporting Special Seismic Certification

 Test Report(s)  Drawings  Calculations  Manufacturer's Catalog Other(s) (Please Specify):

### OSHPD Approval (For Office Use Only) – Approval Expires on December 31, 2025

Signature:  Date: March 8, 2021

Print Name: Timothy J. Piland Title: SSE

Special Seismic Certification Valid Up to:  $S_{DS}$  (g) = 2.00  $z/h$  = 1

Condition of Approval (if applicable):

"Access to Safe, Quality Healthcare Environments that Meet California's Diverse

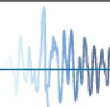
STATE OF CALIFORNIA – HEALTH AND HUMAN SERVICES AGENCY  
OSH-FD-759 (REV 12/16/15)

Page 3 of 3

## Single Package R-410A Air Conditioner

Project Name: **1173 Chicago, IL**

Unit Model #: **ZJ037N06D2B5GCA2R4**

Quantity: **2** Tag #: **RTU-3, RTU-5**

### Seismic Certification

**Table 1 - Certified Components**

Manufacturer: Johnson Controls and other Unitary Product Group brands (York, Coleman, Luxaire, Evcon, Fraser-Johnston and Ready Ship)  
 Product Line: JCI Packaged Rooftop Units

Product Construction: Cabinets constructed of G90 galvanized 1,000 hour salt spray (per ASTM-B117) rated powder-coated 20 gage carbon steel wrapper and duct panel with integral corner posts, all attached at the base to four (4) full perimeter 14 gage base rails with #10 sheet metal screws.

Options: 230-575 V, economizer, power exhaust, electric or gas heater, variable frequency drive

Mounting Description: Rigid or Flexible Curb Mounting

Product Line	Model Number <sup>2</sup>	Dimensions (inches)			Operating Weight (lb)	Nominal Cooling Capacity (Tons)	Sds (g), z/h=1	Unit
		Depth	Width	Height				
Predator Air Handling Units (Short)	ZH/ZU/JA3 037	89	59	42	860 <sup>1</sup>	3	2.0	3
	ZJ/ZW/JA3 037	89	59	42	740	3		Interpolated
	ZR/ZK/JA3 037	89	59	42	980 <sup>1</sup>	3		1
	ZT/ZV/JA3 037	89	59	42	922	3		Interpolated
	ZH/ZU/JA4 049	89	59	42	763	4		Interpolated
	ZJ/ZW/JA4 049	89	59	42	762	4		Interpolated
	ZR/ZK/JA4 049	89	59	42	880	4		Interpolated
	ZT/ZV/JA4 049	89	59	42	960	4		Interpolated
	ZH/ZU/JA5 061	89	59	42	772	5		Interpolated
	ZJ/ZW/JA5 061	89	59	42	1,070 <sup>1</sup>	5		4
	ZR/ZK/JA5 061	89	59	42	1,070 <sup>1</sup>	5		2
	ZT/ZV/JA5 061	89	59	42	968	5		Extrapolated
Predator Air Handling Units (Standard)	XP/XA/J06 078	89	59	42	970 <sup>1</sup>	6.5	2.0	7
	ZF/ZS/J06 078	89	59	42	1,090 <sup>1</sup>	6.5		10
	ZH/ZU/J06 078	89	59	42	910	6.5		Interpolated
	ZJ/ZW/J06 078	89	59	51	1030	6.5		Interpolated
	ZR/ZK/J06 078	89	59	51	1,060 <sup>1</sup>	6.5		5
	ZF/ZS/J07 090	89	59	42	860	7.5		Interpolated
	ZH/ZU/J07 090	89	59	42	910	7.5		Interpolated
	ZJ/ZW/J07 090	89	59	51	1,081	7.5		Interpolated
	XP/XA/J07 090	89	59	42	920	7.5		Interpolated
	ZR/ZK/J07 090	89	59	42	965	7.5		Interpolated
	ZF/ZS/J08 102	89	59	51	1,020	8.5		Interpolated
	ZH/ZU/J08 102	89	59	51	1,030	8.5		Interpolated
	ZJ/ZW/J08 102	89	59	51	1,060	8.5		Interpolated
	XP/XA/J08 102	89	59	51	1,135	8.5		Interpolated
	ZR/ZK/J08 102	89	59	51	1,200	8.5		Interpolated
	ZF/ZS/J10 120	89	59	51	1,060	10		Interpolated
	ZH/ZU/J10 120	89	59	51	1,090	10		Interpolated
	ZJ/ZW/J10 120	89	59	51	1,070	10		Interpolated
	XP/XA/J10 120	89	59	51	1,135	10		Interpolated
	ZR/ZK/J10 120	89	59	51	1,200	10		Interpolated
	ZF/ZS/J12 150	119.5	59	51	1,253	12.5		Interpolated
	ZH/ZU/J12 150	119.5	59	51	1,250 <sup>1</sup>	12.5		11
	XP/XA/J12 150	119.5	59	51	1,510 <sup>1</sup>	12.5		8
	ZJ/ZW/J12 150	119.5	59	51	1,570 <sup>1</sup>	12.5		9
ZR/ZK/J12 150	119.5	59	51	1,600 <sup>1</sup>	12.5	6		
Predator Air Handling Units (Ultra High Efficiency)	ZT/ZV 120	119.5	59	51	1,470 <sup>1</sup>	10	2.0	12
	ZT/ZV 078	119.5	59	51	1,550	6.5		Interpolated
	ZT/ZV 090	119.5	59	51	1,550	7.5		Interpolated
	ZT/ZV 102	119.5	59	51	1,575	8.5		Interpolated
	ZT/ZV 150	119.5	59	51	1,680 <sup>1</sup>	12.5		13

1. Weights listed for tested units are actual, not approximate weights. The weights listed for interpolated units are maximum weights, assuming all optional features are included. Optional features are summarized in the table below.  
 2. Model numbers are generalized for each type of unit and the associated BTU tonnage that the unit can output.

Unit Accessory	Operating Weight (lbs.)
Economizer	85
Power Exhaust	35
Electric Heat	49
Gas Heat	110
Variable Frequency Drive	30

1. Weight given is for the maximum electric heater size available.  
 2. Weight given for the gas heater is for the maximum number of tube heat exchangers available (8 tube).  
 3. Weight includes mounting hardware, controls and manual bypass option.

## Single Package R-410A Air Conditioner

Project Name: 1173 Chicago, IL

Unit Model #: ZJ049N06D2B5GCA2R3

Quantity: 1 Tag #: RTU-4

System: ZJ049N06D2B5GCA2R3

### Cooling Performance

Total gross capacity	48.5 MBH
Sensible gross capacity	35.0 MBH
Total net capacity	45.7 MBH
Sensible net capacity	32.2 MBH
Seasonal Efficiency (at ARI)	15.00 SEER
Efficiency (at ARI)	12.20 EER
Ambient DB temp.	95.0 °F
Entering DB temp.	75.0 °F
Entering WB temp.	61.0 °F
Leaving DB temp.	51.8 °F
Leaving WB temp.	48.2 °F
Leaving air temp dew point	45.00 °F
Power input (w/o blower)	3.20 kW
Sound power	76 dB(A)

### Refrigerant

Refrigerant type	R-410A
Sys1	8 lbs 6 oz

### Gas Heating Performance

Entering DB temp.	60 °F
Heating output capacity (Max)	49.0 MBH
Supply air	1400 CFM
Heating input capacity (Max)	60 MBH
Leaving DB temp.	92.4 °F
Air temp. rise	32.4 °F
SSE	81.0 %
Stages	2

### Supply Air Blower Performance

Supply air	1400 CFM
Ext. static pressure	1.2 IWG
Addl. Unit Losses (Options/Accessories)	0.1 IWG
Blower speed	1009 HP
Max BHP of Motor (including service factor)	1.73 HP
Duct location	Bottom
Motor rating	1.50 HP
Actual required BHP	0.87 HP
Power input	0.81 kW
Elevation	0 ft.
Drive type	BELT

### Outside/Mixed Air

Outside Air CFM	280 CFM
Outside Air DB temp.	95 °F
Outsided Air WB temp.	65 °F
Outside Air RH	18.2 %
Return Air CFM	1120 CFM
Return Air DB temp.	70 °F
Return Air WB temp.	60 °F
Return Air RH	56.1 %

### Electrical Data

Power supply	230-3-60
Unit min circuit ampacity	24.2 Amps
Unit max over-current protection	35 Amps

### Dimensions & Weight

Hgt 42 in.	Len 89 in.	Wth 59 in.
Weight with factory installed options		990 lbs

### Clearances

Right	12 in.	Front	12 in.	Rear	12 in.
Top	12 in.	Bottom	12 in.	Left	12 in.

Note: Please refer to the tech guide for listed maximum static pressures



### 4 Ton

- York Sun Pro units are manufactured at an ISO 9001 registered facility and each rooftop is completely computer-run tested prior to shipment.

### Unit Features

- Single Stage Cooling
- 60 MBH Input Aluminized Steel, Two Stage Gas Heat
- Unit Cabinet Constructed of Powder Painted Steel, Certified At 750 Hours Salt Spray Test (ASTM B-117 Standards)
- Full perimeter base rails with built in rigging capabilities
- Dry Bulb Low Leak Economizer w/Barometric Relief and Hoods (Bottom or Horizontal End Return Only) with Economizer Fault Detection & Diagnostic (Meets ASHRAE 90.1-2013, IECC 2015, California Title 24, AMCA 511).
- Slide-Out Blower/1.5 HP Belt Drive Motor Assembly
- Unit Ships with 2" Pleated Filters (MERV 8)
- Solid Core Liquid Line Filter Driers
- Replacement Filters: 4 - (24" x 16"). Unit accepts 2" or 4" wide filters.
- Non-Powered Convenience Outlet
- HACR Circuit Breaker/Disconnect
- Short Circuit Current: 5kA RMS Symmetrical
- Single Point Power Connection
- Through-the-Curb and Through-the-Base Utility Connections
- Supply Air Smoke Detector
- Micro-Channel "all-aluminum" condenser coil, Copper tube/aluminum fin evaporator coil
- Composite Drain Pan - Back Connection
- Tool-free maintenance with features like hinged doors for all-access panels, slide-out blower and blower motor tray

### Standard Unit Controller: Smart Equipment Control Board

- Safety Monitoring - Monitors the High and Low-Pressure Switches, the Freezestats, the Gas Valve, if Applicable, and the Temperature Limit Switch on Gas and Electric Heat Units. The Unit Control Board will Alarm on Ignition Failures, Safety Lockouts and Repeated Limit Switch Trips.

### Warranty

- One (1) Year Limited Warranty on the Complete Unit
- Five (5) Year Warranty - Compressors and Electric Heater Elements
- Ten (10) Year Limited Warranty - Aluminized Steel Heat Exchanger



# York® Sun™ Pro 3-12.5 Ton Package

Single Package R-410A Air Conditioner

Project Name: 1173 Chicago, IL

Unit Model #: ZJ049N06D2B5GCA2R3

Quantity: 1 Tag #: RTU-4

System: ZJ049N06D2B5GCA2R3

### Additional Electrical Data

Power supply	230-3-60
Unit min circuit ampacity	24.2 Amps
Unit max over-current protection	35 Amps
Min Voltage	187 V
Max Voltage	252 V
Comp #1 RLA	13.8
Comp #1 LRA	83.1
Indoor Mtr Voltage	230-3-60
Indoor Mtr FLA	5.2
Outdoor Mtr Qty	1
Outdoor Fan Voltage	230-1-60
OD Fan Mtr FLA (ea.)	1.65
Power Ex Mtr Qty	1
Powered Ex Voltage	230-1-60
Power Ex Mtr FLA (ea)	5.5
Combustion Mtr Qty	1
Combustion Motor Voltage	208/230-1-60
Combustion Mtr FLA (ea)	0.5



# York® Sun™ Pro 3-12.5 Ton Package

Single Package R-410A Air Conditioner

Project Name: 1173 Chicago, IL

Unit Model #: ZJ049N06D2B5GCA2R3

Quantity: 1 Tag #: RTU-4

System: ZJ049N06D2B5GCA2R3

## Factory Installed Options

### ZJ049N06D2B5GCA2R3

Equipment Options	Option(s) Selected
Product Category:	<b>ZJ</b> Single Packaged R-410A Air Conditioner, High Efficiency 15.0 SEER / 12.2 EER
Nominal Cooling Capacity:	<b>049</b> 4 Ton Single Stage Cooling
Heat Type and Nominal Heat Capacity:	<b>N06</b> 60 MBH Input Aluminized Steel, Two Stage Gas Heat
Blower Option:	<b>D</b> 1.5 HP High Static Belt Drive Blower
Voltage:	<b>2</b> 208/230-3-60
Outside Air Option:	<b>B</b> Dry Bulb Low Leak Economizer w/Barometric Relief and Hoods (Bottom or Horizontal End Return Only) with Economizer Fault Detection & Diagnostic (Meets ASHRAE 90.1-2013, IECC 2015, California Title 24, AMCA 511).
Service Options:	<b>5</b> Non-Powered Convenience Outlet HACR Circuit Breaker/Disconnect
Sensor Options:	<b>G</b> Supply Air Smoke Detector
Controls:	<b>C</b> Smart Equipment Controller including Discharge Air, Return Air, and Outdoor Air Temperature Sensors. BACNet MS/TP, Modbus and N2 Communication Card.
Refrigeration:	<b>A</b> Micro-Channel "all-aluminum" condenser coil, Copper tube/aluminum fin evaporator coil
Additional Options:	<b>2</b> 2" Pleated Filters (MERV 8) Phase Monitor
Cabinet Options:	<b>R</b> Composite Drain Pan - Back Connection Tool-free maintenance with features like hinged doors for all-access panels, slide-out blower and blower motor tray
Product Generation:	<b>3</b>

## Field Installed Accessories

- |   |  |   |
|---|--|---|
| <input type="checkbox"/> 1BD0408 - Burglar Bars (32.0 lbs)                              | <input type="checkbox"/> 1CV0419 - Concentric Diffuser, Specialty, 18X18     | <input type="checkbox"/> 1HA0424 - High Altitude Kit with Propane Conversion - For applications between 2000 and 6000 feet altitude (1.0 lbs) |
| <input type="checkbox"/> 1CG0428 - Coil Guard (20.0 lbs)                                | <input type="checkbox"/> 1FE0412 - Flue Exhaust Extension Kit (14.0 lbs)     |   |
| <input type="checkbox"/> 1CV0402 - Concentric Diffuser, Flush Mount, 18RD               | <input type="checkbox"/> 1FF0415 - 2" Only metal Filter Frame Kit (16.0 lbs) |   |
| <input type="checkbox"/> 1CV0411 - Concentric Diffuser, Side Discharge, 18RD (55.0 lbs) |  |   |



# York® Sun™ Pro 3-12.5 Ton Package

## Single Package R-410A Air Conditioner

Project Name: 1173 Chicago, IL

Unit Model #: ZJ049N06D2B5GCA2R3

Quantity: 1 Tag #: RTU-4

System: ZJ049N06D2B5GCA2R3

- 1HA0447 - High Altitude Kit for Natural Gas - For applications between 2000 and 6000 feet altitude (1.0 lbs)
- 1HG0415 - Hail Guard Kit-Diamond Pattern (50.0 lbs)
- 1HG0431 - Hail Guard Kit-Provent Style (20.0 lbs)
- 1NP0462 - Natural Gas to Propane Conversion Kit (1.0 lbs)
- 1RC0470 - Roof Curb - 8" High, Flat, Uninsulated, Full Perimeter (Shipped Knocked Down) (135.0 lbs)
- 1RC0471 - Roof Curb - 14" High, Flat, Uninsulated, Full Perimeter (Shipped Knocked Down) (135.0 lbs)
- 1RC0476 - Roof Curb - 24" High, Flat, Uninsulated, Full Perimeter (Shipped Knocked Down) (135.0 lbs)
- 1WC0412 - Wooden Crate (445.0 lbs)
- 2AP0402 - Air Proving Switch (1.0 lbs)
- 2AQ04700524 - CO<sup>2</sup> Space Sensor - Wall Mount Accessory (5.0 lbs)
- 2AQ04700624 - CO<sup>2</sup> Unit Mount Accessory (4.6 lbs)
- 2EC0401 - Kit, Single Enthalpy Field Installed (1.0 lbs)
- 2EC0402 - Kit, Dual Enthalpy Field Installed (Includes two humidity sensors) (1.0 lbs)
- 2LA04702412 - Low Ambient Kit - ICM 333 (2.2 lbs)
- 2PE04704706 - Power Exhaust 230V without Baro Relief Downflow or Horizontal (19.0 lbs)
- 2SD04700924 - Smoke Detector Kit w/ Mounting Hardware for Return Air (Downflow Only) Only (10.0 lbs)
- S1-02809570700 - Blower Sheave AK59 for High Static Field Installed Drive (2.0 lbs)
- S1-03102529000 - Non-Networking Wall Sensor – Allows remote sensing and control from single or multiple zones. (0.2 lbs)
- S1-03102529004 - Non-Networking Wall Sensor with Over-ride button – Allows remote sensing and control from single or multiple zones. Override allows setpoint to be overridden for 2 hour time period. (0.2 lbs)
- S1-ADDWIRE - Add-a-Wire allows 5-wire thermostats to use only 4 wires. (0.3 lbs)
- S1-CTSDTS - CTS Wired Temperature Sensor for thermostat | Duct \*Also works for LX Series (0.3 lbs)
- S1-CTSHTS - CTS Hardwired Temperature Sensor for CTS Thermostats \*Works with LX series as well (0.2 lbs)
- S1-CTSPLATE - Wall Plate for CTS Thermostats \*Also works for new platform LX series models below (0.0 lbs)
- S1-CTSWFTS - CTS Temperature Sensor with WiFi for CTS Thermostats \*Also works with LX Series (0.1 lbs)
- S1-LXLOCK - Locking Ring For LX-Series Thermostats (0.4 lbs)
- S1-LXPLATE - Wall Plate For LX-Series Thermostats (0.0 lbs)
- S1-LXWFM - For LX Series Thermostats - WiFi Communication (0.1 lbs)
- S1-MP-PRTKIT-0P - MAP (Multiple Access Portal) Gateway Kit- Replacement MAP gateway protective case, lanyard and communication cable. Use only to replace worn or damaged components. (0.3 lbs)
- S1-NSB8BHN041-0 - Wall Temperature and 3% Relative Humidity Combined Sensor, No Display, WHITE, NO JCI LOGO, NS8000 Series (0.4 lbs)
- S1-NSB8BHN043-0 - Wall Temperature and 3% Relative Humidity Combined Sensor, No Display, BLACK, NO JCI LOGO, NS8000 Series (0.4 lbs)
- S1-NSB8BHN141-0 - Wall Temperature and 3% Relative Humidity Combined Sensor, Warmer/Cooler Display, WHITE, NO JCI LOGO, NS8000 Series (0.4 lbs)
- S1-NSB8BHN143-0 - Wall Temperature and 3% Relative Humidity Combined Sensor, Warmer/Cooler Display, BLACK, NO JCI LOGO, NS8000 Series (0.4 lbs)
- S1-NSB8BHN240-0 - Wall Temperature and 3% Relative Humidity Combined Sensor, Full Display, WHITE, JCI LOGO, NS8000 Series (0.4 lbs)
- S1-NSB8BHN241-0 - Wall Temperature and 3% Relative Humidity Combined Sensor, Full Display, WHITE, NO JCI LOGO, NS8000 Series (0.4 lbs)
- S1-NSB8BHN243-0 - Wall Temperature and 3% Relative Humidity Combined Sensor, Full Display, BLACK, NO JCI LOGO, NS8000 Series (0.4 lbs)
- S1-NSB8BPN240-0 - Wall Temperature and 2% Relative Humidity Combined Sensor, Full Display, WHITE, JCI LOGO, NS8000 Series (0.4 lbs)
- S1-NSB8BPN241-0 - Wall Temperature and 2% Relative Humidity Combined Sensor, Full Display, WHITE, NO JCI LOGO, NS8000 Series (0.4 lbs)
- S1-NSB8BPN243-0 - Wall Temperature and 2% Relative Humidity Combined Sensor, Full Display, BLACK, NO JCI LOGO, NS8000 Series (0.4 lbs)
- S1-NSB8BTN041-0 - Wall Temperature Sensor, No Display, WHITE, NO JCI LOGO, NS8000 Series (0.4 lbs)
- S1-NSB8BTN043-0 - Wall Temperature Sensor, No Display, BLACK, NO JCI LOGO, NS8000 Series (0.4 lbs)
- S1-NSB8BTN141-0 - Wall Temperature Sensor, Warmer/Cooler Display, WHITE, NO JCI LOGO, NS8000 Series (0.4 lbs)
- S1-NSB8BTN143-0 - Wall Temperature Sensor, Warmer/Cooler Display, BLACK, NO JCI LOGO, NS8000 Series (0.4 lbs)
- S1-NSB8BTN240-0 - Wall Temperature Sensor, Full Display, WHITE, JCI LOGO, NS8000 Series (0.4 lbs)



# York® Sun™ Pro 3-12.5 Ton Package

## Single Package R-410A Air Conditioner

Project Name: 1173 Chicago, IL

Unit Model #: ZJ049N06D2B5GCA2R3

Quantity: 1 Tag #: RTU-4

System: ZJ049N06D2B5GCA2R3

- S1-NSB8BTN241-0 - Wall Temperature Sensor, Full Display, WHITE, NO JCI LOGO, NS8000 Series (0.4 lbs)
- S1-NSB8BTN243-0 - Wall Temperature Sensor, Full Display, BLACK, NO JCI LOGO, NS8000 Series (0.4 lbs)
- S1-TEC3030-14-000 - 7 DAY PROGRAMMABLE THERMOSTAT, ZIGBEE PRO WIRELESS COMMUNICATION, RTU/HEAT PUMP WITH ECON, FULL COLOR, WHITE, JCI LOGO (0.8 lbs)
- S1-TEC3030-16-000 - 7 DAY PROGRAMMABLE THERMOSTAT, ZIGBEE PRO WIRELESS COMMUNICATION, RTU/HEAT PUMP WITH ECON, AND FULL COLOR, WHITE, NO LOGO (0.8 lbs)
- S1-TEC3031-14-000 - 7 DAY PROGRAMMABLE THERMOSTAT, ZIGBEE PRO WIRELESS COMMUNICATION, RTU/HEAT PUMP WITH ECON, OCC SENSOR, FULL COLOR, WHITE, JCI LOGO (0.8 lbs)
- S1-TEC3031-16-000 - 7 DAY PROGRAMMABLE THERMOSTAT, ZIGBEE PRO WIRELESS COMMUNICATION, RTU/HEAT PUMP WITH ECON, OCC SENSOR, FULL COLOR, WHITE, NO LOGO (0.8 lbs)
- S1-TEC3630-14-000 - 7 DAY PROGRAMMABLE THERMOSTAT, OPTIONAL MSTP OR N2 COMMUNICATION, RTU/HEAT PUMP WITH ECON, FULL COLOR, WHITE, JCI LOGO (0.8 lbs)
- S1-TEC3630-16-000 - 7 DAY PROGRAMMABLE THERMOSTAT, OPTIONAL MSTP OR N2 COMMUNICATION, RTU/HEAT PUMP WITH ECON, FULL COLOR, WHITE, NO LOGO (0.8 lbs)
- S1-TEC3631-14-000 - 7 DAY PROGRAMMABLE THERMOSTAT, OPTIONAL MSTP OR N2 COMMUNICATION, RTU/HEAT PUMP WITH ECON, OCC SENSOR, FULL COLOR, WHITE, JCI LOGO (0.8 lbs)
- S1-TEC3631-16-000 - 7 DAY PROGRAMMABLE THERMOSTAT, OPTIONAL MSTP OR N2 COMMUNICATION, RTU/HEAT PUMP WITH ECON, OCC SENSOR, FULL COLOR, WHITE, NO LOGO (0.8 lbs)
- S1-YK/AN-RSO-ACI - Non-Networking Wall Sensor with Setpoint Adjustment and Over-ride Button – Allows remote sensing and control from single or multiple zones. (1.0 lbs)
- S1-YK-MAP1810-0P - MAP (Multiple Access Portal) Gateway- For use with SimplicitySE Control. (0.2 lbs)
- S1-YK-MAP1810-0S - Stationary MAP Gateway (Includes MAP Gateway, Field Bus Adapter, Mounting Bracket and 100 to 240 VAC Power Supply). US-compatible counties. (1.9 lbs)

Project Name: 1173 Chicago, IL

Unit Model #: ZJ049N06D2B5GCA2R3

Quantity: 1 Tag #: RTU-4

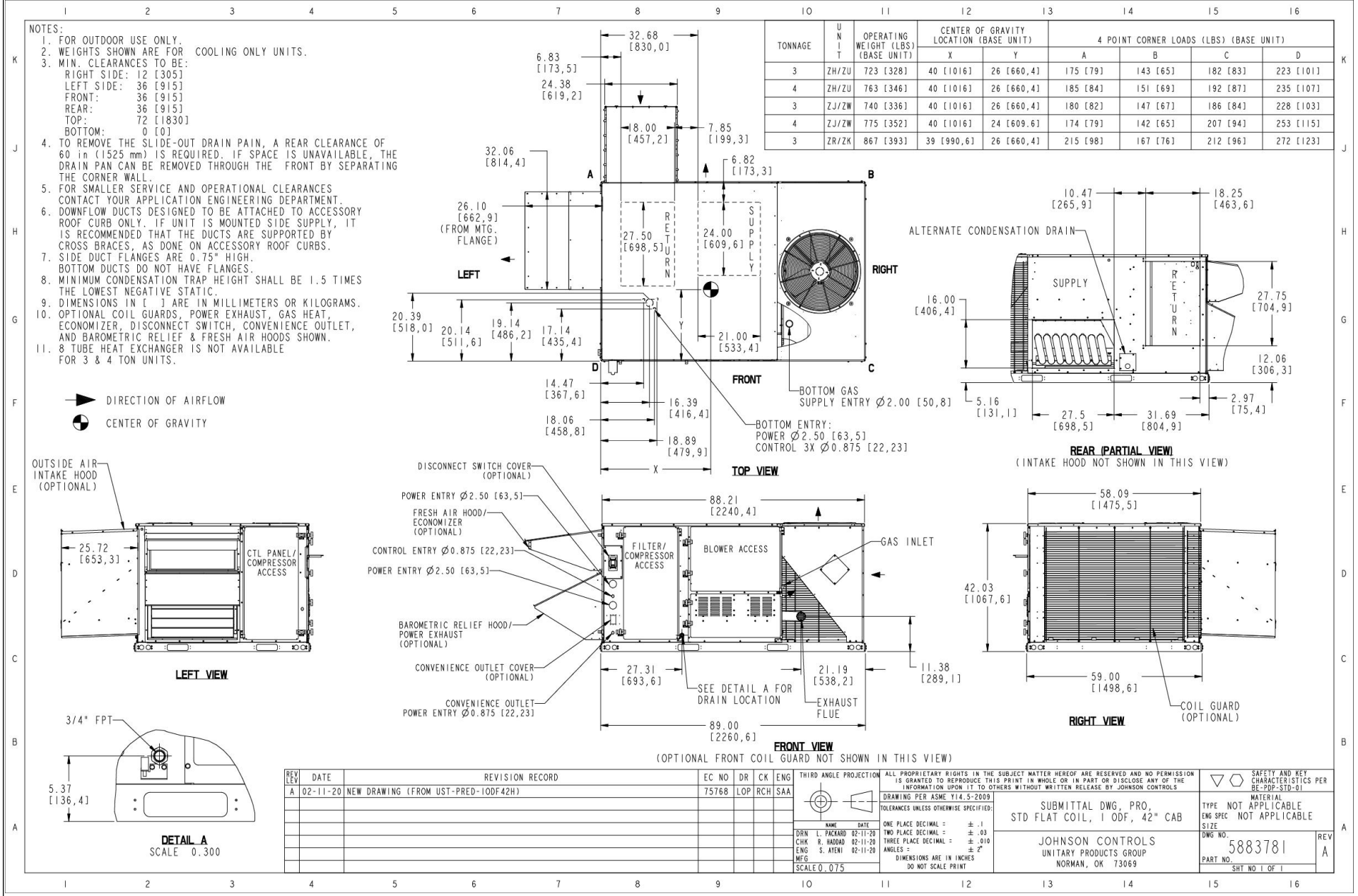
**Consolidated Drawing**

Project Name: 1173 Chicago, IL

Unit Model #: ZJ049N06D2B5GCA2R3

Quantity: 1 Tag #: RTU-4

### Component Locations

#### Component Location

##### Cooling With Gas Heat (3 Through 5 Ton)

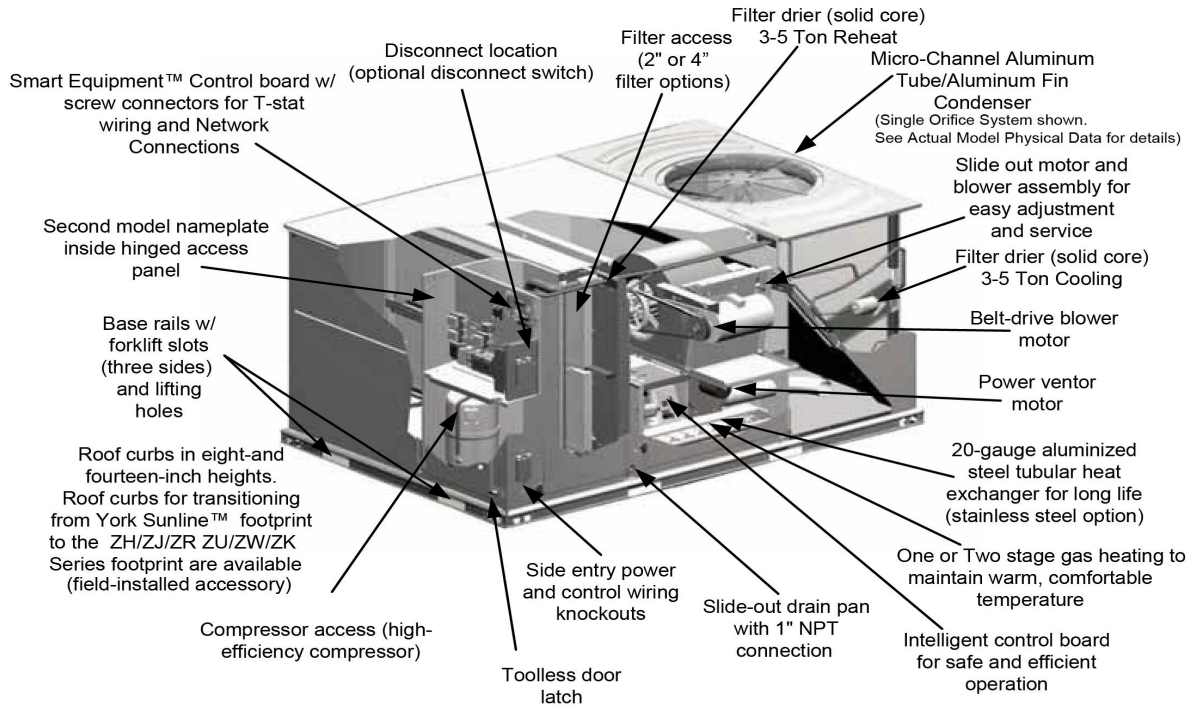

### Low Leak Downflow Economizer

### Low Leak Downflow Economizer (shown with optional Power Exhaust)

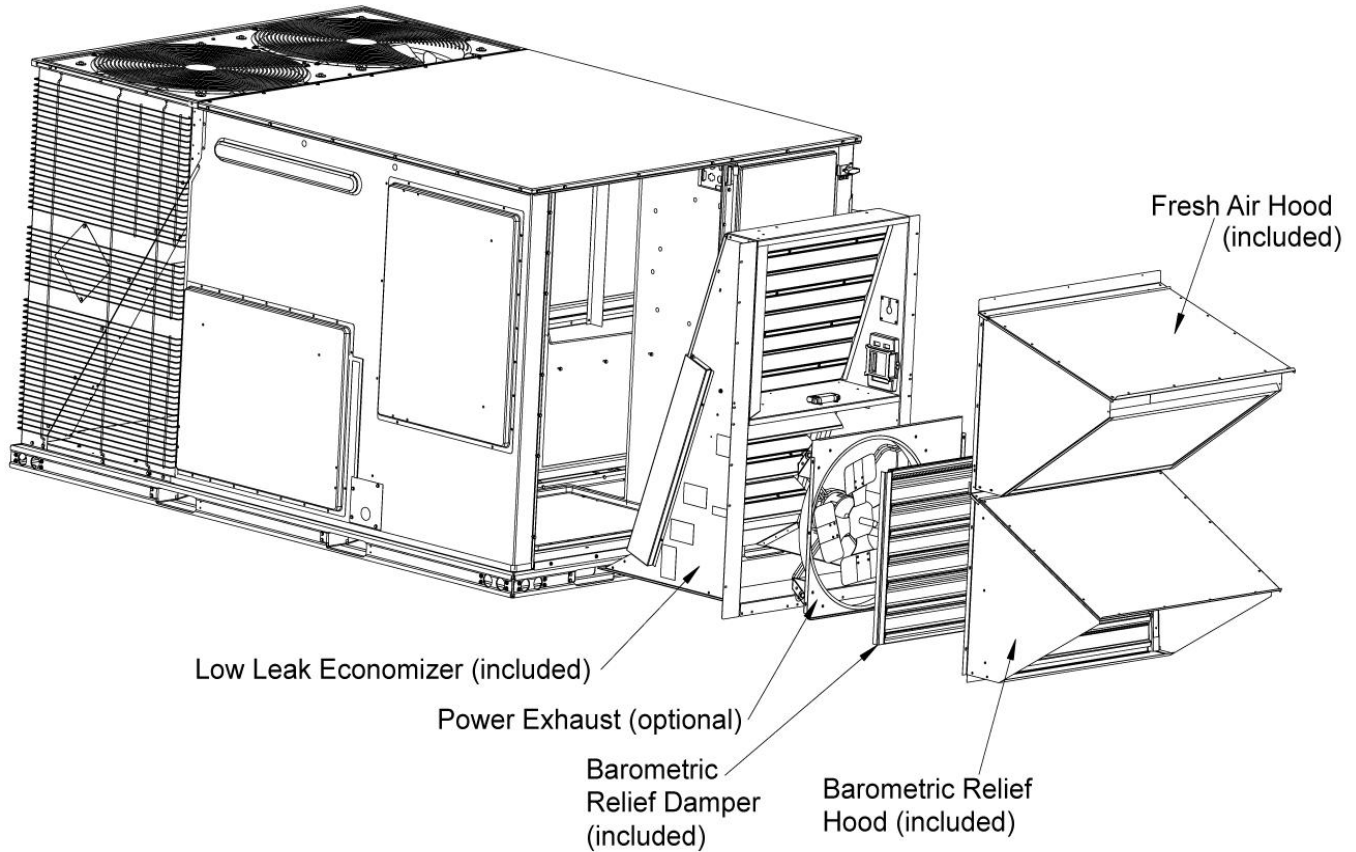

Low leak economizers are capable achieving low leakage rates of 3 cfm/sq. ft at 1" of static pressure, meeting or exceeding the following standards:

- ASHRAE 90.1-2010
- ASHRAE 62
- AMCA 511 (licensed as Class 1A damper)
- International Energy Conservation Code (IECC)
- California Title 24

The outdoor intake opening shall be covered with a rain hood that matches the exterior of the unit. Water eliminator/filters shall be provided.

Simultaneous economizer/compressor operation is also possible. Dampers shall fully close on power loss.

## Single Package R-410A Air Conditioner

Project Name: 1173 Chicago, IL

Unit Model #: ZJ049N06D2B5GCA2R3

Quantity: 1 Tag #: RTU-4

### Seismic Certification



OFFICE OF STATEWIDE HEALTH PLANNING AND DEVELOPMENT  
FACILITIES DEVELOPMENT DIVISION

### APPLICATION FOR OSHPD SPECIAL SEISMIC CERTIFICATION PREAPPROVAL (OSP)

OFFICE USE ONLY

APPLICATION #: OSP - 0213

#### OSHPD Special Seismic Certification Preapproval (OSP)

Type:  New  Renewal

#### Manufacturer Information

Manufacturer: Johnson Controls Inc. (JCI)

Manufacturer's Technical Representative: Cameron Boyce, Engineer II

Mailing Address: 5005 Interstate Drive, Norman, OK, 73069

Telephone: (405) 419-6830

Email: [cameron.w.boyce@jci.com](mailto:cameron.w.boyce@jci.com)

#### Product Information

Product Name: Predator Rooftop Air Conditioning Units

Product Type: Packaged Air Conditioning Units OSP-0213

Product Model Number: See attached

(List all unique product identification numbers and/or part numbers)

The units are enclosures with the following subcomponents: refrigerant compressors, outdoor fan motors, indoor coils, outdoor coils, reversing valve with coil, thermostatic expansion valves, standard indoor blower motor, Variable frequency drive indoor blower motor, exhaust fan motor, variable frequency drive, economizer, electric heater, heat cells, filters, and other miscellaneous items included in the subcomponent tables.

Mounting Description: Units are rigid curb and isolated curb base mounted

#### Applicant Information

Applicant Company Name: The VMC Group

Contact Person: John Giuliano

Mailing Address: 113 Main Street, Bloomingdale, NJ 07403

Telephone: (973) 838-1780

Email: [john.giuliano@thevmcgroup.com](mailto:john.giuliano@thevmcgroup.com)

I hereby agree to reimburse the Office of Statewide Health Planning and Development review fees in accordance with the California Administrative Code, 2016.

Signature of Applicant: 

Date: 8/28/19

Title: President

Company Name: The VMC Group

"Access to Safe, Quality Healthcare Environments that Meet California's Diverse

STATE OF CALIFORNIA - HEALTH AND HUMAN SERVICES AGENCY  
OSH-FD-759 (REV 12/16/15)

Page 1 of 3

## Single Package R-410A Air Conditioner

Project Name: 1173 Chicago, IL

Unit Model #: ZJ049N06D2B5GCA2R3

Quantity: 1 Tag #: RTU-4

### Seismic Certification



#### OFFICE OF STATEWIDE HEALTH PLANNING AND DEVELOPMENT FACILITIES DEVELOPMENT DIVISION

#### California Licensed Structural Engineer Responsible for the Engineering and Test Report(s)

Company Name: The VMC GroupName: Kenneth Tarlow California License Number: SE-2851Mailing Address: 113 Main Street, Bloomingdale, NJ 07403Telephone: (973) 838-1780 Email: [ken.tarlow@thvmcgroup.com](mailto:ken.tarlow@thvmcgroup.com)

#### Supports and Attachments Preapproval

- Supports and attachments are preapproved under OPM- \_\_\_\_\_  
(Separate application for OSHPD Preapproval of Manufacturer's Certification (OPM) of Supports and attachments is required)
- Supports and attachments are not preapproved

#### Certification Method

- Testing in accordance with:  ICC-ES AC156
- Other (Please Specify): \_\_\_\_\_

#### Testing Laboratory

Company Name: DCL LabsContact Name: Josh Sailer, Laboratory ManagerMailing Address: 1315 Greg Street, Suite 109, Sparks, NV 89431Telephone: (775) 358-5085 Email: [josh@shaketest.com](mailto:josh@shaketest.com)

"Access to Safe, Quality Healthcare Environments that Meet California's Diverse

STATE OF CALIFORNIA – HEALTH AND HUMAN SERVICES AGENCY  
OSH-FD-759 (REV 12/16/15)



Page 2 of 3

## Single Package R-410A Air Conditioner

Project Name: 1173 Chicago, IL

Unit Model #: ZJ049N06D2B5GCA2R3

Quantity: 1 Tag #: RTU-4

### Seismic Certification



## OFFICE OF STATEWIDE HEALTH PLANNING AND DEVELOPMENT FACILITIES DEVELOPMENT DIVISION

### Seismic Parameters

Design in accordance with ASCE 7-16 Chapter 13:  Yes  NoDesign Basis of Equipment or Components ( $F_p/W_p$ ) = Rigid Curb = 1.5; Spring Isolated Curb = 4.5 $S_{DS}$  (Design spectral response acceleration at short period, g) = 2.00 $a_p$  (In-structure equipment or component amplification factor) = 2.5 $R_p$  (Equipment or component response modification factor) = Rigid Curb = 6.0; Spring Isolated Curb = 2.0 $\Omega_0$  (System overstrength factor) = 2.0 $I_p$  (Importance factor) = 1.5 $z/h$  (Height factor ratio) = 1

Equipment or Component Natural Frequencies (Hz) = See attachment

Overall dimensions and weight (or range thereof) = See attachment

Equipment or Components @ grade designed in accordance with ASCE 7-16 Chapter 15:  Yes  NoDesign Basis of Equipment or Components ( $V/W$ ) = $S_{DS}$  (Design spectral response acceleration at short period, g) = $S_{D1}$  (Design spectral response acceleration at 1 second period, g) = $R$  (Response modification coefficient) = $\Omega_0$  (System overstrength factor) = $C_d$  (Deflection amplification factor) = $I_p$  (Importance factor) = 1.5

Height to Center of Gravity above base =

Equipment or Component Natural Frequencies (Hz) =

Overall dimensions and weight (or range thereof) =

Tank(s) designed in accordance with ASME BPVC, 2015:  Yes  No

### List of Attachments Supporting Special Seismic Certification

 Test Report(s)  Drawings  Calculations  Manufacturer's Catalog Other(s) (Please Specify):

### OSHPD Approval (For Office Use Only) – Approval Expires on December 31, 2025

Signature:  Date: March 8, 2021

Print Name: Timothy J. Piland Title: SSE

Special Seismic Certification Valid Up to:  $S_{DS}$  (g) = 2.00  $z/h$  = 1

Condition of Approval (if applicable):

"Access to Safe, Quality Healthcare Environments that Meet California's Diverse

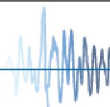
STATE OF CALIFORNIA – HEALTH AND HUMAN SERVICES AGENCY  
OSH-FD-759 (REV 12/16/15)

Page 3 of 3

## Single Package R-410A Air Conditioner

Project Name: **1173 Chicago, IL**

Unit Model #: **ZJ049N06D2B5GCA2R3**

Quantity: **1** Tag #: **RTU-4**

### Seismic Certification

**Table 1 - Certified Components**

Manufacturer: Johnson Controls and other Unitary Product Group brands (York, Coleman, Luxaire, Evcon, Fraser-Johnston and Ready Ship)

Product Line: JCI Packaged Rooftop Units

Product Construction: Cabinets constructed of G90 galvanized 1,000 hour salt spray (per ASTM-B117) rated powder-coated 20 gage carbon steel wrapper and duct panel with integral corner posts, all attached at the base to four (4) full perimeter 14 gage base rails with #10 sheet metal screws.

Options: 230-575 V, economizer, power exhaust, electric or gas heater, variable frequency drive

Mounting Description: Rigid or Flexible Curb Mounting

Product Line	Model Number <sup>2</sup>	Dimensions (inches)			Operating Weight (lb)	Nominal Cooling Capacity (Tons)	Sds (g), z/h=1	Unit
		Depth	Width	Height				
Predator Air Handling Units (Short)	ZH/ZU/JA3 037	89	59	42	860 <sup>1</sup>	3	2.0	3
	ZJ/ZW/JA3 037	89	59	42	740	3		Interpolated
	ZR/ZK/JA3 037	89	59	42	980 <sup>1</sup>	3		1
	ZT/ZV/JA3 037	89	59	42	922	3		Interpolated
	ZH/ZU/JA4 049	89	59	42	763	4		Interpolated
	ZJ/ZW/JA4 049	89	59	42	762	4		Interpolated
	ZR/ZK/JA4 049	89	59	42	880	4		Interpolated
	ZT/ZV/JA4 049	89	59	42	960	4		Interpolated
	ZH/ZU/JA5 061	89	59	42	772	5		Interpolated
	ZJ/ZW/JA5 061	89	59	42	1,070 <sup>1</sup>	5		4
	ZR/ZK/JA5 061	89	59	42	1,070 <sup>1</sup>	5		2
	ZT/ZV/JA5 061	89	59	42	968	5		Extrapolated
Predator Air Handling Units (Standard)	XP/XA/J06 078	89	59	42	970 <sup>1</sup>	6.5	2.0	7
	ZF/ZS/J06 078	89	59	42	1,090 <sup>1</sup>	6.5		10
	ZH/ZU/J06 078	89	59	42	910	6.5		Interpolated
	ZJ/ZW/J06 078	89	59	51	1030	6.5		Interpolated
	ZR/ZK/J06 078	89	59	51	1,060 <sup>1</sup>	6.5		5
	ZF/ZS/J07 090	89	59	42	860	7.5		Interpolated
	ZH/ZU/J07 090	89	59	42	910	7.5		Interpolated
	ZJ/ZW/J07 090	89	59	51	1,081	7.5		Interpolated
	XP/XA/J07 090	89	59	42	920	7.5		Interpolated
	ZR/ZK/J07 090	89	59	42	965	7.5		Interpolated
	ZF/ZS/J08 102	89	59	51	1,020	8.5		Interpolated
	ZH/ZU/J08 102	89	59	51	1,030	8.5		Interpolated
	ZJ/ZW/J08 102	89	59	51	1,060	8.5		Interpolated
	XP/XA/J08 102	89	59	51	1,135	8.5		Interpolated
	ZR/ZK/J08 102	89	59	51	1,200	8.5		Interpolated
	ZF/ZS/J10 120	89	59	51	1,060	10		Interpolated
	ZH/ZU/J10 120	89	59	51	1,090	10		Interpolated
	ZJ/ZW/J10 120	89	59	51	1,070	10		Interpolated
	XP/XA/J10 120	89	59	51	1,135	10		Interpolated
	ZR/ZK/J10 120	89	59	51	1,200	10		Interpolated
	ZF/ZS/J12 150	119.5	59	51	1,253	12.5		Interpolated
	ZH/ZU/J12 150	119.5	59	51	1,250 <sup>1</sup>	12.5		11
	XP/XA/J12 150	119.5	59	51	1,510 <sup>1</sup>	12.5		8
	ZJ/ZW/J12 150	119.5	59	51	1,570 <sup>1</sup>	12.5		9
ZR/ZK/J12 150	119.5	59	51	1,600 <sup>1</sup>	12.5	6		
Predator Air Handling Units (Ultra High Efficiency)	ZT/ZV 120	119.5	59	51	1,470 <sup>1</sup>	10	2.0	12
	ZT/ZV 078	119.5	59	51	1,550	6.5		Interpolated
	ZT/ZV 090	119.5	59	51	1,550	7.5		Interpolated
	ZT/ZV 102	119.5	59	51	1,575	8.5		Interpolated
	ZT/ZV 150	119.5	59	51	1,680 <sup>1</sup>	12.5		13

1. Weights listed for tested units are actual, not approximate weights. The weights listed for interpolated units are maximum weights, assuming all optional features are included. Optional features are summarized in the table below.

2. Model numbers are generalized for each type of unit and the associated BTU tonnage that the unit can output.

Unit Accessory	Operating Weight (lbs.)
Economizer	85
Power Exhaust	35
Electric Heat	49
Gas Heat	110
Variable Frequency Drive	30

1. Weight given is for the maximum electric heater size available.

2. Weight given for the gas heater is for the maximum number of tube heat exchangers available (8 tube).

3. Weight includes mounting hardware, controls and manual bypass option.

**Date**

03/08/2023

**Project Name**

1173 Chicago, IL

**Project Number****Client / Purchaser****Guide Specification Summary Page**

<b>Product Series</b>	<b>Models and Unit Tags</b>	
Sun Choice 15-27.5 Ton Package	AW15N3DQ2S1CDS62A2	RTU-1
York® Sun™ Pro 3-12.5 Ton Package	ZT150N24R2B5GCA2R2	RTU-2
	ZJ037N06D2B5GCA2R4	RTU-3, RTU-5
	ZJ049N06D2B5GCA2R3	RTU-4

**12.5 to 23 Tons Nominal Cooling  
178,000 to 324,000 BTUH Nominal Gas Heating Output  
25 to 75 kW Electric Heating**

**23 06 80 Schedules for Decentralized HVAC Equipment**

- 23 06 80. 13 Decentralized Unitary HVAC Equipment Schedule
- 23 06 80. 13.A. Rooftop unit schedule
  - 1. Schedule is per the project specification requirements.

**23 07 16. HVAC Equipment Insulation**

- 23 07 16. 13 Decentralized, Rooftop Units:
  - 23 07 16. 13.A. Evaporator fan compartment:
    - 1. Interior cabinet surfaces shall be insulated with a minimum 0.5 in. thick, fiber glass insulation with thermal conductivity of 0.23 or better, adhered with water based adhesive.
    - 2. Insulation and adhesive shall meet NFPA 90A requirements for flame spread and smoke generation.
  - 23 07 16. 13.B. Gas heat compartment:
    - 1. Interior cabinet surfaces shall be insulated with a minimum 0.5 in. thick, fiber glass insulation with thermal conductivity of 0.23 or better, adhered with water based adhesive.
    - 2. Insulation and adhesive shall meet NFPA 90A requirements for flame spread and smoke generation.
  - 23 07 16. 13.C. Economizer and Control compartment:
    - 1. Shall be Interior cabinet surfaces shall be insulated with a minimum 0.5 in. thick, fiber glass insulation with thermal conductivity of 0.23 or better, adhered with water based adhesive.
    - 2. Insulation and adhesive shall meet NFPA 90A requirements for flame spread and smoke generation.
  - 23 07 16. 13.D. Partition and Duct Panel:
    - 1. Interior cabinet surfaces shall be insulated with a minimum 0.5 in. thick, fiber glass insulation with thermal conductivity of 0.23 or better, adhered with water based adhesive.
    - 2. Insulation and adhesive shall meet NFPA 90A requirements for flame spread and smoke generation.
  - 23 07 16. 13.E. Base Pan and Blower Back:
    - 1. Interior cabinet surfaces shall be insulated with a minimum 0.5 in. thick, foil faced fiber glass insulation with thermal conductivity of 0.23 or better, adhered with water based adhesive.
    - 2. Insulation and adhesive shall meet NFPA 90A requirements for flame spread and smoke generation.

**23 09 13 Instrumentation and Control Devices for HVAC**

- 23 09 13. 23 Sensors and Transmitters
- 23 09 13. 23.A. Thermostats
  - 1. Thermostat must
    - a. Energize "Y" when calling for cooling and "W" when calling for heating.
    - b. Shall have capability to energize 4 different stages of cooling, and 2 different stages of heating.
    - c. Shall include capability for occupancy scheduling.

**23 09 23 Direct- digital Control system for HVAC**

- 23 09 23. 13 Decentralized, Rooftop Units:
  - 23 09 23. 13.A. Simplicity SMART Equipment Control
    - 1. Shall be ASHRAE 62 compliant.
    - 2. Shall accept 20-30 VAC input power, 50/60Hz. 24 VAC nominal.
    - 3. Shall have an operating temperature range from -40°F to 158°F; 10-90% RH (non-condensing UI), and -4°F to 158°F; 10-90% RH (non-condensing), with a storage temperature range from -40°F to 194°F; 5-95% RH (non-condensing).
    - 4. Shall include an option of an Economizer microprocessor controller which communicates directly with the Unit Control Board and has 8 Analog outputs, 2 Analog inputs, 2 Binary outputs, 3 Binary inputs.
    - 5. Controller shall accept the following inputs: space temperature, return air temperature sensor, set point adjustment, outdoor air temperature, indoor air quality, outdoor air quality, indoor relative humidity, compressor lock- out, fire/smoke

- shutdown, single and dual enthalpy, fan status, remote time clock, Sensor Actuator (SA) Bus communicated temperature/humidity/CO2 values from Network sensors, Field Controller (FC) Bus Network Overrides for space temperature, outdoor air temperature, space humidity, outdoor air quality, Indoor air quality, System purge.
6. Shall accept a CO2 sensor or multiple CO2 sensors networked together in the conditioned space, and be Demand Control Ventilation (DCV) ready.
  7. Shall provide compressor short-cycle protection with minimum compressor runtime set at 3 minutes standard and adjustable from 2 to 7 minutes.
  8. Unit shall provide surge protection for the controller through a circuit breaker.
  9. Shall have open communication protocols with all required points exposed. Protocols supported include: BACnet®, MS/TP, Modbus®, and N2 communication.
  10. Shall have an LCD display on the Unit Control Board to display fault messages as well as navigate the menu structure to review and change set points.
  11. Shall utilize a USB connection to allow for uploading and downloading of data.
    - a. USB shall allow for downloading of “trending data” for analysis of inputs and values on other device such as a PC.
    - b. USB shall allow for uploading of new firmware to the UCB.
    - c. USB shall allow for backing up controller set points and parameters and for uploading of these same parameters to the UCB.
  12. Shall include an RJ-12 port to be used with a Wi-Fi signal transmitting device and allow unit(s) access via any non-proprietary smart device.
    - a. Unit access shall include ability to view and change all adjustable parameters and set points using the same characteristics and values available directly through the UCB joystick and LCD display.
    - b. Unit access shall be configurable at 3 different levels to allow control over parameter and set point changes.
    - c. Wi-Fi transmitting device can be connected by 3 means.
      - 1) RJ-12 port connected directly to UCB.
      - 2) Optional connection port mounted in operating space.
      - 3) Optional connection to building network allowing unit access from any internet browser worldwide.
  13. Shall have the capability to integrate with Verasys zoning controls system.
  14. Shall not require any proprietary software or contractor tool to start-up, commission and troubleshoot unit operation.
  15. Software upgrades will be accomplished by local download via USB port on main Unit Control Board.
  16. Shall be UL Recognized, File E107041, UL 916, Energy management Equipment, UL 60335-2-40, Heating and Cooling Equipment; FCC Compliant to CFR47, Part 15, Subpart B, Class B, CSA 22.2 No. 236, Signal Equipment Industry Canada, ICES-003 Recognized, and BTL certified.

## **23 09 33 Electric and Electronic Control System for HVAC**

23 09 33. 13 Decentralized, Rooftop Units:

23 09 33. 13.A. General

1. Shall be complete with self- contained low- voltage control circuit protected by a resettable circuit breaker on the 24- v transformer side. Transformer shall have minimum 75VA capability.
2. Shall utilize color- coded wiring.
3. Shall include a central control terminal board to conveniently and safely provide connection points for vital control functions such as: smoke detectors, phase monitor, gas controller, economizer, thermostat, DDC control options, and low and high pressure switches.
4. The gas furnace shall be controlled by an integrated gas controller (IGC) microprocessor. See heat exchanger section of this specification.

23 09 33. 23.B. Safeties:

1. Compressor over- temperature and over- current.
2. Low pressure switch and high pressure switch.
  - a. Low pressure switch shall use different color wire than the high pressure switch. The purpose is to assist the installer and service technician to correctly wire and or troubleshoot the rooftop unit.
3. Automatic reset, motor thermal overload protector.
4. Gas heating section shall be provided with the following minimum protections.
  - a. Primary and auxiliary high temperature limit switches

- b. Induced draft pressure sensor
- c. Flame rollout switch
- d. Flame proving controls
- 5. Electric heat section shall be provided with the following minimum protections:
  - a. Primary, backup and auxiliary high temperature limit switches

**23 40 13 Panel Air Filters**

23 40 13 13. Decentralized, Rooftop Units:

23 40 13. 13.A. Standard filter section

- 1. Shall consist of factory installed, low velocity, disposable 2- in. thick fiberglass filters of commercially available sizes.
- 2. Units can accept 2" or 4" filters and have a field convertible transition.
- 3. Filters shall be accessible through an access panel; hinged panel with toolless access is available as described in the Special Features Options and Special Features Options and Accessories section of this specification.

**23 81 19 Self- Contained Air Conditioners**

23 81 19 13. Small- Capacity Self- Contained Air Conditioners

23 81 19. 13.A. General

- 1. Outdoor, rooftop mounted, electrically controlled, heating and cooling unit utilizing a fully hermetic, suction gas cooled, direct drive compressor(s) for cooling duty and gas combustion or nickel chromium elements for heating duty.
- 2. Factory assembled, single- piece heating and cooling rooftop unit. Contained within the unit enclosure shall be all factory wiring, piping, controls, and special features required prior to field start- up.
- 3. Unit shall use environmentally sound, R-410A refrigerant.
- 4. Unit shall be installed in accordance with the manufacturer's instructions.
- 5. Unit must be selected and installed in compliance with local, state, and federal codes.

23 81 19. 13.B. Quality Assurance

- 1. Unit meets ASHRAE 90.1 minimum efficiency requirements.
- 2. Unit shall be rated in accordance with AHRI Standards 210/240 or 340/360.
- 3. Unit shall be designed to conform to ASHRAE 15.
- 4. Unit shall be CSA tested and certified in accordance with ANSI Z21.47 -2016/CSA 2.3-2016, and CSA C22.2 No. 60335-2-40.
- 5. Insulation and adhesive shall meet NFPA 90A requirements for flame spread and smoke generation.
- 6. Unit casing shall be capable of withstanding 750- hour salt spray exposure per ASTM B117 (scribed specimen).
- 7. Roof curb shall be designed to conform to NRCA Standards.
- 8. Unit shall be subjected to a completely automated run test on the assembly line. The data for each unit will be stored at the factory, and must be available upon request.
- 9. Unit shall be designed in accordance with CSA C.22.2 NO.60335-2-40, including tested to withstand rain.
- 10. Unit shall be constructed to prevent intrusion of snow into the control box.
- 11. 15 – 25 ton units shall be shake tested to Truck 2, ASTM D4169 to ensure shipping reliability.

23 81 19. 13.C. Delivery, Storage, and Handling

- 1. Unit shall be stored and handled per manufacturer's recommendations.
- 2. Overhead crane can be used to place the units on a roof using rigging holes built into the unit base rails without any additions to the unit.
- 3. Unit shall only be stored or positioned in the upright position.

23 81 19. 13.D. Project Conditions

- 1. As specified in the contract.

23 81 19. 13.E. Operating Characteristics

- 1. Unit shall be capable of starting and running at 115°F (52°C) ambient outdoor temperature, meeting maximum load criteria of AHRI Standard 210/240 or 340/360 at ±10% voltage.
- 2. Compressor with standard controls shall be capable of operation down to 45°F (7°C), ambient outdoor temperatures. Intermittent cooling shall be operational down 0° F (-17° C).

3. Unit shall be factory configured for vertical supply & return configurations.
- 23 81 19. 13.F. Electrical Requirements
  1. Main power supply voltage, phase, and frequency must match those required by the manufacturer.
- 23 81 19. 13.G. Unit Cabinet
  1. Unit cabinet shall be constructed of galvanized steel with exterior surfaces coated with a non-chalking, powder paint finish, certified at 750 hour salt spray test per ASTM-B117 standards.
  2. Unit cabinet exterior paint shall be: film thickness, (dry) 3.0 MILS minimum, gloss (per ASTM D523, 60°F / 16°C): 80+/- 5, Hardness: H- 2H Pencil hardness.
  3. Unit cabinet shall have gas utility entry holes in the side of the unit and in the unit underside. Entry holes shall not require field setup and shall be capped from the factory to prevent water intrusion when not in use.
  4. Unit cabinet shall have electric utility entry locations marked from the factory with a dimple for accuracy of field drilling. Entry locations shall be available for entry through the side of the unit or from the unit underside.
5. Base Rail
  - a. Unit shall have base rails on all 4 sides.
  - b. Holes shall be provided in the base rails for rigging shackles to facilitate maneuvering and overhead rigging.
  - c. Holes shall be provided in the base rail for moving the unit by fork truck.
  - d. Base rail shall be a minimum of 15 gauge thickness.
6. Condensate pan and connections:
  - a. Shall be a multidirectional internally sloped condensate drain pan made of a non- corrosive material.
  - b. Shall comply with ASHRAE Standard 62.
  - c. Shall use a 1" NPT female drain connection through the side of the drain pan. Connection shall be made per manufacturer's recommendations.
  - d. Shall include intentional "overflow notch" and water containment path to guide flow of water where desired in the event of a drain pan overflow.
7. Top panel:
  - a. Shall be a multi piece top panel.
8. Electrical Connections
  - a. All unit power wiring shall enter unit cabinet through a field drilled hole located by a factory provided dimple.
  - b. Through- the- base capability.
    - 1) Standard unit shall have a through- the- base electrical location(s) using a raised, embossed portion of the unit base-pan.
    - 2) No base-pan penetration, other than those authorized by the manufacturer, is permitted.
- 23 81 19. 13.H. Gas Heat
  1. General
    - a. Heat exchanger shall be an induced draft design. Positive pressure heat exchanger designs shall not be allowed.
    - b. Shall incorporate a direct- spark ignition system and redundant main gas valve.
    - c. Gas supply pressure at the inlet to the rooftop unit gas valve must match that required by the manufacturer.
    - d. Burners shall be of the in- shot type constructed of aluminum- coated steel.
    - e. Burners shall incorporate orifices for rated heat output up to 2000 ft. (610m) elevation. Additional accessory kits may be required for applications above 2000 ft. (610m) elevation, depending on local gas supply conditions.
    - f. Each heat exchanger tube shall contain multiple dimples for increased heating effectiveness.
  2. The gas furnace shall be controlled by an integrated gas controller (IGC) microprocessor.
    - a. IGC board shall notify users of fault using an LED (light- emitting diode).
    - b. Unit shall be equipped with anti- cycle protection with one cycle on the unit flame rollout switch, 3 short cycles on the high temperature limit switch, one cycle on the auxiliary limit switch, and one cycle on indoor blower fault detection. Fault indication shall be made using an LED.
  3. Staged gas heat
    - a. Shall have two stages of heating capacity with first stage capacity 75% of total capacity.
  4. Aluminized Steel Heat Exchanger construction.

- a. Heat exchanger shall be of the tubular- section type constructed of a minimum of 20- gauge steel coated with a T1-40 aluminum-silicon alloy for corrosion resistance.
- 5. Induced draft combustion motor and blower
  - a. Shall be a direct- drive, single inlet, forward- curved centrifugal type.
  - b. Shall be made from steel with a corrosion- resistant finish.
  - c. Shall have permanently lubricated sealed bearings.
  - d. Shall have inherent thermal overload protection with automatic reset feature.
- 23 81 19. 13.I. Coils
  - 1. Evaporator Coils, Aluminum Fin - Copper Tube:
    - a. Standard evaporator coils shall have aluminum plate fins mechanically bonded to seamless internally grooved copper tubes with all joints brazed.
    - b. Shall be leak tested to 150 psig, pressure tested to 250 psig, and burst qualified to CSA C22.2 No. 60335-2-40.<sup>th</sup> edition burst test at 1775 psig.
    - c. Assembled unit shall be pressure tested to 450 psig.
  - 2. Condenser Coils, All Aluminum Microchannel:
    - a. Condenser coils shall have all aluminum microchannel design consisting of aluminum multiport flat tube design and aluminum fin. Coils shall be a furnace brazed design and contain epoxy lined shrink wrap on all aluminum to copper connections.
    - b. Microchannel condenser coils shall be leak tested to 150 psig, pressure tested by supplier to 600 psig, and burst qualified to CSA C22.2 No. 60335-2-40.
    - c. Assembled unit shall be pressure tested to 450 psig.
- 23 81 19. 13.J. Refrigerant Circuits
  - 1. 4 speed IntelliSpeed and Variable Air Volume airflow options shall have 2 independent refrigerant circuits with variable cooling control.
  - 2. Refrigerant circuit shall include the following control, safety, and maintenance features:
    - a. Thermostatic Expansion Valve (TXV) shall help provide optimum performance across the entire operating range.
    - b. Refrigerant filter drier - Solid core design.
    - c. Service gauge connections on suction and discharge lines.
  - 3. Compressors
    - a. Unit shall use fully hermetic scroll compressors for each independent refrigeration circuit.
    - b. Variable capacity models that are 12.5 or 15 tons shall use a variable speed compressor on circuit one and a two stage compressor on circuit two.
    - c. Compressor motors shall be cooled by refrigerant gas passing through motor windings.
    - d. Compressors shall be internally protected from high discharge temperature conditions.
    - e. Compressors shall be protected from an over- temperature and over- amperage conditions by an internal, motor overload device.
    - f. Compressor shall be factory mounted on rubber grommets.
    - g. Crankcase heaters shall be installed in the factory as needed on tandem compressor sets.
- 23 81 19. 13.K. Filter Section
  - 1. Filters access is specified in the unit cabinet section of this specification.
- 23 81 19. 13.L. Evaporator Fan and Motor
  - 1. Evaporator fan motor:
    - a. Shall have permanently lubricated ball-bearings.
    - b. Shall have inherent automatic- reset thermal overload protection.
    - c. The job site selected brake horsepower shall be required to not exceed the motor's nameplate horsepower rating plus the service factor.
  - 2. Evaporator Fan:
    - a. Fan shall be a belt drive assembly with an adjustable pitch motor pulley.
    - b. Blower bearings shall have an L10 life of 100,000 hrs
    - c. Shall use sealed, permanently lubricated ball-bearing type.

- d. Shall use dual blower design consisting of two balanced blower fans on a single shaft.
  - e. Blower fan shall be double- inlet type with forward- curved blades.
  - f. Shall be constructed from steel with a corrosion resistant finish and dynamically balanced.
- 23 81 19. 13.M. Condenser Fans and Motors
- 1. ECM condenser fan motors:
    - a. Shall be a totally enclosed motor.
    - b. Shall use permanently lubricated ball-bearings.
    - c. Shall have inherent thermal overload protection with an automatic reset feature.
    - d. Shall use a shaft- down design.
  - 2. Condenser Fans:
    - a. Shall be a direct- driven propeller type fan.
- 23 81 19. 13.N. Special Features Options and Accessories
- 1. IntelliSpeed staged air volume system:
    - a. Evaporator fan motor:
      - 1) Shall have permanently lubricated bearings.
      - 2) Shall have a maximum continuous bhp rating for continuous duty operation; no safety factors above that rating.
      - 3) Shall be Variable Frequency duty and multi-speed control.
  - 2. Variable Frequency Drive (VFD). Available on multi-speed (IntelliSpeed) and VAV indoor fan motor options:
    - a. Shall be installed inside the unit cabinet, mounted, wired and tested.
    - b. Shall contain Electromagnetic Interference (EMI) frequency protection.
    - c. Insulated Gate Bi- Polar Transistors (IGBT) used to produce the output pulse width modulated (PWM) waveform.
    - d. Built in LED display and controls. Does not require additional kit or options.
    - e. RS485 capability standard.
    - f. Electronic thermal overload protection.
    - g. All printed circuit boards shall be conformal coated.
  - 3. Low Leak Economizer:
    - a. Integrated, tie-bar driven parallel modulating blade design type capable of simultaneous economizer and compressor operation.
    - b. Damper blades shall be galvanized steel with tie-bar metal linkages. Plastic or composite blades on intake or return shall not be acceptable.
    - c. Damper blades shall be class 1A dampers.
    - d. Shall include all hardware and controls to provide free cooling with outdoor air when temperature and/or humidity are below set points.
    - e. Shall be equipped with tie-bar driven dampers for both the outdoor ventilation air and the return air for positive air stream control.
    - f. Economizer shall comply with, and be certified to, the AMCA 511 standard.
    - g. Standard leak rate shall be equipped with dampers not to exceed 3 cfm/ft<sup>2</sup> leakage at 1 in. wg pressure differential.
    - h. Economizer controller shall be the Johnson Controls SE Economizer Controller
      - 1) On- board Fault Detection and Diagnostics (FDD) that senses and alerts when the economizer is not operating properly, meets the requirements for California Title 24, IECC 2015, and ASHRAE 90.1.
      - 2) Display alarms if the following occur
        - i. Economizer is economizing when conditions do not support
        - ii. Economizer is not economizing when conditions do support
        - iii. Damper Stuck
        - iv. Excess Outdoor Air
        - v. Failed Sensor
      - 3) Automatic sensor detection

- 4) Capabilities for use with multiple-speed indoor fan systems
- 5) Utilize digital sensors: Dry bulb and Enthalpy
- 6) UL, CSA, and ICES-003 recognized and FCC compliant to CFR47
- i. Shall be capable of introducing up to 100% outdoor air.
- j. Shall be equipped with a barometric relief damper capable of relieving up to 100% return air and contain seals that meet ASHRAE 90.1 requirements. Barometric relief can be replaced by optional power exhaust.
- k. Shall be designed to close damper(s) during loss- of- power situations with spring return built into motor.
- l. Dry bulb outdoor air temperature sensor shall be provided as standard. Single or dual enthalpy sensing is available as a factory or field installed sensing option. Outdoor air sensor set point shall be adjustable and shall range from 40° to 80°F / 4° to 27°C. Additional sensor options shall be available as accessories.
- m. The economizer controller shall also provide control of an accessory power exhaust unit function. Factory set at 100%, with a range of 0% to 100%.
- n. The economizer shall maintain minimum airflow into the building during occupied period and provide design ventilation rate for full occupancy.
- o. Dampers shall be completely closed when the unit is in the unoccupied mode.
- p. Economizer controller shall accept a 2- 10 Vdc CO2 sensor input for IAQ/DCV control. In this mode, dampers shall modulate the outdoor air damper to provide ventilation based on the sensor input.
- q. Economizer controller shall provide indications when in free cooling mode, in the DCV mode, or the exhaust fan contact is closed.
4. Barometric Relief Damper:
  - a. Shall contain all materials necessary to field install a barometric relief damper capable of relieving up to 100% return air and contain seals that meet ASHRAE 90.1 requirements.
5. MagnaDry Dehumidification System:
  - a. The MagnaDry Dehumidification system is factory installed and provides dehumidification of an occupied space while maintaining temperature control utilizing a hot gas reheat coil.
    - 1) Determination of unit functionality in straight cooling, straight heating, or reheat mode shall come from standard SSE control board.
    - 2) Reheat mode shall utilize a specific reheat coil placed after the evaporator coil to heat the conditioned air back to a neutral temperature when the occupied space requires dehumidification, but the temperature requirements are satisfied.
    - 3) The reheat circuit shall utilize a 3-way electronic controlled valve to modulate the refrigerant between the condenser circuit and reheat circuit.
    - 4) Changeover from cooling mode to reheat mode shall be accomplished in 30 seconds or less.
6. Phase Monitor:
  - a. Shall provide protection against phase reversal, phase loss, and phase unbalance.
  - b. Switch shall automatically shut off unit control circuit if any of the above conditions is detected.
  - c. Shall have visual LED indication of operational status.
7. Unit-Mounted, Non-Fused Disconnect Switch:
  - a. Switch shall be factory installed, internally mounted.
  - b. National Electric Code (NEC) and UL approved non- fused switch shall provide unit power shutoff.
  - c. Shall be accessible from outside the unit.
  - d. Shall provide local shutdown and lockout capability.
8. Non-Powered convenience outlet:
  - a. Outlet shall be powered from a separate 115/120v power source.
  - b. A transformer shall not be included.
  - c. Outlet shall be factory installed and internally mounted with easily accessible 115- v female receptacle.
  - d. Outlet shall include 15 amp GFI receptacles with independent fuse protection.
  - e. Outlet shall be accessible from outside the unit.
9. Dual Enthalpy Sensor:
  - a. The dual enthalpy sensor option or kit shall provide 2 relative humidity sensors to be mounted in the return and outdoor air streams to provide dual enthalpy economizer control.

- b. This kit contains all components required for dual enthalpy control and does not need to be used in conjunction with the Single Enthalpy Sensor Kit.
10. CO2 Sensor:
- a. Shall be able to provide demand ventilation control for indoor air quality (IAQ).
  - b. The CO2 sensor shall be available in duct mount or wall mount with LED display.
  - c. The set-points for IAQ and OAQ shall have adjustment capability between 0 and 5000 ppm in the Simplicity Smart Equipment controls.
11. Smoke detectors:
- a. Shall be a Four- Wire Controller and Detector.
  - b. Shall be environmental compensated with differential sensing for reliable, stable, and drift- free sensitivity.
  - c. Shall use magnet- activated test/reset sensor switches.
  - d. Shall have a recessed momentary switch for testing and resetting the detector.
  - e. Controller shall include.
    - 1) One set of normally open alarm initiation contacts for connection to an initiating device circuit on a fire alarm control panel.
    - 2) Two Form- C auxiliary alarm relays for interface with rooftop unit or other equipment.
    - 3) One Form- C supervision (trouble) relay to control the operation of the Trouble LED on a remote test/ reset station.
    - 4) Capable of direct connection to two individual detector modules.
    - 5) Can be wired to up to 49 other duct smoke detectors for multiple fan shutdown applications.

## GENERAL

York® Sun™ Pro units are convertible single packages with a common footprint cabinet and common roof curb for all 3 through 12-1/2 ton models. All 6-1/2 through 12-1/2 ton have two compressors with independent R-410A refrigeration circuits to provide 2 stages of cooling. The units were designed for light commercial applications and can be easily installed on a roof curb, slab, or frame. All units are self contained and assembled on rigid full perimeter base rails allowing for 3-way forklift access and overhead rigging. Every unit is completely charged with R-410A, wired, piped, and tested at the factory to provide a quick and easy field installation. All units are convertible between side and down airflow. Independent economizer designs are used on side and down discharge applications, as well as all tonnage sizes. Predator® units are available in the following configurations: cooling only, cooling with electric heat, cooling with gas heat, reheat only, reheat with electric heat and reheat with gas heat. Electric heaters are available as factory-installed options or field-installed accessories.

## DESCRIPTION

Units shall be factory assembled, single package, (Elec/Elec, Gas/ Elec), designed for outdoor installation. They shall have built in field convertible duct connections for down discharge supply/return or horizontal discharge supply/return and be available with factory installed options or field installed accessories. The units shall be factory wired, piped and charged with R-410A refrigerant and factory tested prior to shipment. All unit wiring shall be both numbered and color coded. The cooling performance shall be rated in accordance with DOE and AHRI test procedures. Units shall be CSA certified to ANSI Z21.47 and UL 1995/CAN/CSA No. 236-M90 standards.

## UNIT CABINET

Unit cabinet shall be constructed of galvanized steel with exterior surfaces coated with a non-chalking, powder paint finish, certified at a 750-hour salt spray test per ASTM-B117 standards. Indoor blower sections shall be insulated with up to 1" thick insulation coated on the airside. Either aluminum foil faced or elastometric rubber insulation shall be used in the unit's compartments and be fastened to prevent insulation from entering the air stream. Cabinet doors shall be hinged with toolless access for easy servicing and maintenance. Full perimeter base rails shall be provided to assure reliable transit of equipment, overhead rigging, fork truck access and proper sealing on roof curb applications. Disposable 2" filters shall be furnished as standard and be accessible through hinged access door. Fan performance measuring ports shall be provided on the outside of the cabinet to allow accurate air measurements of evaporator fan performance without

removing panels or creating bypass of the coils. Condensate pan shall be slide out design, constructed of a non corrosive material, internally sloped and conforming to ASHRAE 62-B9 standards. Condensate connection shall be a minimum of 3/4" I.D. female and be rigid mount connection.

## INDOOR (EVAPORATOR) FAN ASSEMBLY

Fan shall be a belt drive assembly and include an adjustable pitch motor pulley. Job site selected brake horsepower shall not exceed the motors nameplate horsepower rating plus the service factor. Units shall be designed to operate within the service factor. Fan wheel shall be double inlet type with forward curve blades, dynamically balanced to operate smoothly throughout the entire range of operation. Airflow design shall be constant volume. Bearings shall be sealed and permanently lubricated for longer life and no maintenance. Entire blower assembly and motor shall be slide out design.

## OUTDOOR (CONDENSER) FAN ASSEMBLY

The outdoor fans shall be of the direct drive type, discharge air vertically, have aluminum blades riveted to corrosion resistant steel spider brackets and shall be dynamically balanced for smooth operation. The outdoor fan motors shall have permanently lubricated bearings internally protected against overload conditions and staged independently. A cleaning window shall be provided on two sides of the units for coil cleaning.

## REFRIGERANT COMPONENTS

### Compressors:

- a. Shall be fully hermetic type, direct drive, internally protected with internal high-pressure relief and over temperature protection. The hermetic motor shall be suction gas cooled and have a voltage range of + or - 10% of the unit nameplate voltage.
- b. Shall have internal spring isolation and sound muffling to minimize vibration and noise, and be externally isolated on a dedicated, independent mounting.

### Coils:

- a. Evaporator coils shall have aluminum plate fins mechanically bonded to seamless internally enhanced copper tubes with all joints brazed. Special Phenolic coating shall be available as a factory option.
- b. Evaporator coils shall be of the direct expansion, draw-thru design.
- c. Condenser coils shall have aluminum plate fins mechanically bonded to seamless internally enhanced copper tubes with all joints brazed or Micro-Channel aluminum tube, aluminum fins.
- d. Condenser coils shall be of the draw-thru design.

Refrigerant Circuit and Refrigerant Safety Components shall include:

- a. Independent fixed-orifice or thermally operated expansion devices.
- b. Solid core filter drier/strainer to eliminate any moisture or foreign matter.
- c. Accessible service gage connections on both suction and discharge lines to charge, evacuate, and measure refrigerant pressure during any necessary servicing or troubleshooting, without losing charge.
- d. The 6-1/2 through 12-1/2 ton unit shall have two independent refrigerant circuits, equally split in 50% capacity increments.

Unit Controls:

- a. Unit shall be complete with self-contained low-voltage control circuit protected by a resettable circuit breaker on the 24-volt transformer side.
- b. Unit shall incorporate a lockout circuit which provides reset capability at the space thermostat or base unit should any of the following standard safety devices trip and shut off compressor:
  - Loss-of-charge/Low-pressure switch.
  - High-pressure switch.
  - Freeze condition sensor on evaporator coil. If any of these safety devices trip, the LCD screen will display the alarm message.
- c. Unit shall incorporate "AUTO RESET" compressor over temperature, over current protection.
- d. Unit shall operate with conventional thermostat designs and have a low voltage terminal strip for easy hook-up.
- e. Unit control board shall have on-board diagnostics and fault message display.
- f. Standard controls shall include anti-short cycle and low voltage protection, and permit cooling operation down to a selectable value as low as 0 °F.
- g. Control board shall monitor each refrigerant safety switch independently.

## GAS HEATING SECTION

Heat exchanger and exhaust system shall be constructed of aluminized steel, and be designed with induced draft combustion with post purge logic, energy saving direct spark ignition, and redundant main gas valve. The heat exchanger shall be of the tubular type, constructed of T1-40 aluminized steel for corrosion resistance and allowing minimum mixed air entering temperature of 40 °F. Burners shall be of the in-shot type, constructed of aluminum-coated steel. All gas piping shall enter the unit cabinet at a single location, through either the side or bottom, without any field modifications. An integrated control board shall provide timed control of evaporator fan functioning and burner ignition. Heating section shall be provided with the following minimum protection:

- a. Primary and auxiliary high-temperature limit switches.
- b. Induced draft pressure sensor.
- c. Flame roll out switch (manual reset).
- d. Flame proving controls.
- e. All two stage gas units shall have two independent stages of capacity (70% or 75% 1st stage, 100% 2nd stage) 3 through 5 ton and (60% 1st stage, 100% 2nd stage) 6-1/2 through 12-1/2 ton.

## UNIT OPERATING CHARACTERISTICS

Unit shall be capable of starting and running at 125 °F outdoor temperature, exceeding maximum load criteria of AHRI Standard 340/360. The compressor, with standard controls, shall be capable of operation down to 0 °F outdoor temperature. Unit shall be provided with fan time delay to prevent cold air delivery before heat exchanger warms up. (Gas heat only)

**ELECTRICAL REQUIREMENTS** - All unit power wiring shall enter unit cabinet at a single factory provided location and be capable of side or bottom entry to minimize roof penetrations and avoid unit field modifications. Separate side and bottom openings shall be provided for the control wiring.

**STANDARD LIMITED WARRANTIES** - Compressor – 5 Years, Heat Exchanger – 10 Years, Elect. Heat Elem. – 5 Years, Parts – 1 Year.

**FACTORY INSTALLED OPTIONAL OUTDOOR AIR**  
(Shall be made available by either/or):

- **DRY BULB AUTOMATIC ECONOMIZER** – Outdoor and return air dampers that are interlocked and positioned by a fully-modulating, spring-return damper actuator. The maximum leakage rate for the outdoor air intake dampers shall be designed to meet ASHRAE 90.1, AMCA 511 Class 1A damper, and the International Energy Conservation Code (IECC) certification requirements by achieving leakage rates of 3 CFM/sq. ft. at 1" of static pressure. Changeover from compressor to economizer operation shall be provided by an integral electronic enthalpy control that feeds input into the basic module. The outdoor intake opening shall be covered with a rain hood that matches the exterior of the unit. Water eliminator/filters shall be provided.  
Simultaneous economizer/compressor operation is also possible. Dampers shall fully close on power loss.

#### **ADDITIONAL FACTORY INSTALLED OPTIONS**

- **Alternate Indoor Blower Motor** – For applications with high restrictions, units are available with optional indoor blower motors that provide higher static output and/or higher airflow.
- **IntelliSpeed™ Supply Fan Control Option (ASHRAE 90.1 compliant, section 6.4.3.10)** – Units configured with the IntelliSpeed™ Supply Fan Option will contain a VFD for variable volume supply fan operation. This option allows the supply fan RPM to vary based on the number of compressors or heating stages energized. The economizer's minimum position will also be configurable to vary based on the supply fan VFD frequency output.
- **Non-Powered Convenience Outlet** – Unit is provided with a non-powered 120VAC GFCI outlet with cover on the corner of the unit housing the compressors.
- **BAS Controls** – Include supply air sensor, return air sensor, dirty filter indicator and air proving switch.
- **Smoke Detector** – A smoke detector can be factory mounted and wired in the supply and/or return air compartments.

#### **FIELD INSTALLED OPTIONS**

**Date**

03/08/2023

**Project Name**

1173 Chicago, IL

**Project Number**

**Client / Purchaser**

### Control Summary Page

Control	Models and Unit Tags
BACnet MSTP,MdbS,N2 COM Card	AW15N3DQ2S1CDS62A2 RTU-1
	ZT150N24R2B5GCA2R2 RTU-2
	ZJ037N06D2B5GCA2R4 RTU-3, RTU-5
	ZJ049N06D2B5GCA2R3 RTU-4

**23 09 23 Direct- digital Control system for HVAC**23 09 23. 13 Decentralized, Rooftop Units:23 09 23. 13.A. Unit Control Board

1. ASHRAE 62- 2001 compliant. BTL certified.
2. Shall accept 20-30 VAC input power, 50/60Hz. 24 VAC nominal.
3. Operating temperature range from -40F to 158F; 10-90% RH (non-condensing UI), and -4F to 158F; 10-90% Rh (non-condensing), with a storage temperature range from -40F to 194F; 5-95% RH (non-condensing).
4. Shall include an option of and Economizer microprocessor controller which communicates directly with the Unit Control Board and has 8 Analog outputs, 2 Analog inputs, 2 Binary outputs, 3 Binary outputs.
5. Controller shall accept the following inputs: space temperature, return air temperature sensor, setpoint adjustment, outdoor air temperature, indoor air quality, outdoor air quality, indoor relative humidity, compressor lock- out, fire/smoke shutdown, single and dual enthalpy, fan status, remote time clock, SA Bus communicated temperature/humidity/CO2 values from Network sensors, FC Bus Network Overrides for space temperature, outdoor air temperature, space humidity, outdoor air quality, Indoor air quality, System purge.
6. Shall accept a single CO2 sensor or multiple CO2 sensors networked together via communication bus in the conditioned space, and be Demand Control Ventilation (DCV) ready.
7. Shall provide the following outputs: economizer, fan, cooling stage 1, cooling stage 2, heat stage 1, heat stage 2, heat stage 3/ exhaust/ reversing valve/ dehumidify/occupied.
8. Unit shall provide surge protection for the controller through a circuit breaker.
9. Shall be Internet capable, and communicate at a Baud rate of 38.4K or faster.
10. Shall have an LED display independently showing the status of activity on the communication bus, and processor operation.
11. Unit shall incorporate a lockout circuit which provides reset capability at the space thermostat or base unit should any of the following standard safety devices trip and shut off compressor. If any of these safety devices trip, the LCD screen will display alarm message indicating the specific safety device that caused the lockout.
  - a. Loss of charge/Low-pressure switch.
  - b. High-pressure switch.
  - c. Freeze condition sensor on evaporator coil.
12. Unit control board must support each usage case:
  - a. Conventional thermostat with low voltage input terminals for easy installation
  - b. Communicating network sensors in the occupied space to provide feedback on space conditions for unit control board to compare with associated setpoints
  - c. Communication via BACnet MS/TP, Modbus RTU, N2 protocols for integration into a building automation/management system
13. Anti-short cycle and low voltage protection features included.
14. Internal occupied/unoccupied scheduling
15. Unit control board shall permit cooling operation down to a selectable value as low as 0 degrees F.
16. Shall allow for start-up, commissioning, troubleshooting, parameter adjustment, setpoint adjustment via onboard display and navigable menu with no additional interface tool or controls technician required.
17. The unit control board shall run a self-test diagnostics algorithm at startup that operated the cooling cycle, heating cycle, fan operation. A status report shall be provided upon completion of the diagnostic self-test.
18. Utilize any wi-fi enabled smart device to access the HVAC or multiple HVAC units if communication wiring between them is present (FC Bus or SA Bus). Remote access shall allow complete ability to perform start-up, commissioning, troubleshooting, parameter adjustment, setpoint adjustment.
19. Local embedded trending and scheduling. Trending data and occupancy scheduling predefined from the factory. Occupancy schedule to be modified via control board joystick menu navigation and remotely using a smart device (cellular phone, laptop, tablet)
20. A menu on the onboard screen shall display the unit status and allow changing parameters where applicable. These include but are not limited to:
  - a. Demand Ventilation Mode – enable or disable
  - b. Operational Setpoint – display current value
  - c. Supply Air Temperature (SAT) – display current value
  - d. Return Air Temperature (RAT) – display current value

- e. Operational Supply Humidity (OprSH) – display current value as provided by a 0-10VDS input, SA Bus Network Sensor, or FC Bus communicated value
  - f. Return Air Humidity (RAH) – display current value
  - g. Operational outdoor Air Temperature (OprOAT) – enthalpy calculated from OAH 0-10VDC input to Economizer board and OprOAT only if economizer is present
  - h. Operational Outdoor Air Humidity (OprOAH) – the buffered outdoor air humidity. May be from economizer boards OAH 0-10VDC input or FC Bus communicated value
  - i. Operational outdoor Air Quality (OprOAQ) – the buffered outdoor air quality in use. May be from economizer boards OAQ 0-10VDC input or FC Bus communicated value
  - j. Operational Indoor Air Quality (OprIAQ) – the buffered indoor air quality in use. May be from economizer board IAQ 0-10VDC input, SA Bus Network Sensor, or FC Bus communicated value
21. A menu shall display and allow modification to the following operations and settings:
- a. HVAC Zone Fan
  - b. Cooling
  - c. Heating
  - d. Economizer
  - e. Demand Ventilation
  - f. Power Exhaust
  - g. Sensors
  - h. Network
22. A menu shall display and allow modification to the following operations and settings:
- a. HVAC Zone – Occupied status
  - b. Indoor Fan status
  - c. Cooling status
  - d. Heating status
  - e. Economizer indication whether free-cooling is available or not
  - f. Enabling or disabling of Demand Ventilation
  - g. Power Exhaust
    - 1) Enable/disable hot-gas reheat if available
    - 2) Warmup/Cooldown
    - 3) Title 24 Load Shed
    - 4) Defrost
23. A menu shall display and allow modification to the following operations and settings:
- a. Firmware version (of UCB, Economizer, other peripheral boards)
  - b. Setting time zone
  - c. Network information
    - 1) Device name that will appear on the FC Bus
    - 2) Selection of communication protocol
    - 3) Operational Baud Rate
    - 4) Device ID
24. A menu shall display and allow modification to the following operations and settings:
- a. Version of firmware
  - b. Ability to Load new firmware
  - c. Create a backup file of the firmware and parameter setting via USB port
  - d. Restore factory default parameter values and setup
  - e. Full and Partial Cloning of parameter setpoints from or to other units
  - f. Data trend exporting
25. A menu shall display and allow modification to the following operations and settings:

- a. Unit serial number, model number and name
- b. Ability to reset Lockouts
- c. Controller name
- d. Displays the current values of all setpoints in use
- e. Displays all current values for the indoor and outdoor zones
- f. Displays current values related to:
  - 1) Indoor Fan
  - 2) Cooling
  - 3) Heating
  - 4) Heat Pump operation
  - 5) Economizer operation
  - 6) Power Exhaust
  - 7) Demand Ventilation
  - 8) Air monitoring station
  - 9) Hot Gas Reheat
  - 10) Smoke Control
- g. Current information for inputs; including
  - 1) Sensors
  - 2) Coil Sensors
  - 3) Thermostat
  - 4) Binary Inputs
  - 5) Unit Protection
  - 6) Network Inputs
  - 7) All outputs (relay and binary)
- h. Self-Test
  - 1) A patented self-test system that runs through a series of algorithms to provide a report of all functioning characteristics of the system at time of startup and commissioning.

23 09 23. 13.B. Auxiliary Control Boards

1. ASHRAE 62- 2001 compliant. BTL certified.
2. Economizer controller CEC Title 24 Compliant
  - a. Display alarms if the following occur
    - 1) Economizer is economizing when conditions do not support
    - 2) Economizer is not economizing when conditions do support
    - 3) Damper Stuck
    - 4) Excess Outdoor Air
    - 5) Failed Sensor
3. Refrigeration Fault Detection & Diagnostics
  - a. There is insufficient refrigerant in any circuit
  - b. There is excessive refrigerant in any circuit
  - c. There is excessive refrigerant flow
  - d. There is insufficient refrigerant flow (restriction)
  - e. Inefficient compressor
  - f. Insufficient High-side heat transfer
  - g. Excessive High-side heat transfer (low ambient control problem, low  $\Delta P$ )
  - h. Insufficient Low-side heat transfer
  - i. Excessive Low-side heat transfer

- j. Sensor fault- The liquid temperature is greater than the condenser temperature (Could also be triggered if refrigerant level is very low in the system)
- k. Sensor fault- Sensor data is not available
- l. The unit is off
- m. The ambient temperature is too low
- n. The ambient temperature is too high
- o. The return air wet-bulb temperature is too low
- p. The return air wet-bulb temperature is too high
- q. Sensor fault- The condensing temperature is lower than the ambient temperature (Could also be triggered when the condenser is wet)
- r. The suction line temperature is less than the evaporator temperature
- s. The evaporator temperature is greater than the ambient temperature
- t. The liquid temperature is lower than the ambient temperature
- u. Sensor fault- Suction temperature or ambient temperature is invalid
- v. Sensor fault- The return air dry-bulb or wet-bulb temperature is invalid
- w. Sensor fault- The liquid pressure or suction pressure is invalid
- x. Sensor fault- The suction line temperature is invalid
- y. The return air dry-bulb temperature is too low
- z. The return air dry-bulb temperature is too high
- aa. The Efficiency Index is below 75% of ideal
- bb. The Capacity Index is below 75% of ideal

23 09 23. 13.C Remote Accessibility:

1. ASHRAE 62- 2001 compliant. BTL certified.
2. Provide the ability to adjust parameter values, setpoints, limits remotely
3. Connectivity to an Ethernet network via static IP address or Dynamic Name Server (DNS)
4. Allow a maximum of 100 devices on the same FC bus trunk and accessed by one remote device

# START-UP & SERVICE DATA INSTRUCTION

## COMMERCIAL PACKAGE UNITS

3.0 To 40.0 TONS

---

### START-UP CHECKLIST

Date: \_\_\_\_\_

Job Name: \_\_\_\_\_

Customer Name: \_\_\_\_\_

Address: \_\_\_\_\_

City: \_\_\_\_\_ State: \_\_\_\_\_ Zip: \_\_\_\_\_

Model Number: \_\_\_\_\_ Serial Number: \_\_\_\_\_

Qualified Start-up Technician: \_\_\_\_\_ Signature: \_\_\_\_\_

HVAC Contractor: \_\_\_\_\_ Phone: \_\_\_\_\_

Address: \_\_\_\_\_

Contractor's E-mail Address: \_\_\_\_\_

Electrical Contractor: \_\_\_\_\_ Phone: \_\_\_\_\_

Distributor Name: \_\_\_\_\_ Phone: \_\_\_\_\_

### WARRANTY STATEMENT

Johnson Controls/UPG is confident that this equipment will operate to the owner's satisfaction if the proper procedures are followed and checks are made at initial start-up. This confidence is supported by the 30 day dealer protection coverage portion of our standard warranty policy which states that Johnson Controls/UPG will cover parts and labor on new equipment start-up failures that are caused by a defect in factory workmanship or material, for a period of 30 days from installation. Refer to current standard warranty policy and warranty manual found on UPGnet for details.

In the event that communication with Johnson Controls/UPG is required regarding technical and/or warranty concerns, all parties to the discussion should have a copy of the equipment start-up sheet for reference. A copy of the original start-up sheet should be filed with the Technical Services Department.

The packaged unit is available in constant or variable air volume versions with a large variety of custom options and accessories available. Therefore, some variation in the startup procedure will exist depending upon the products capacity, control system, options and accessories installed.

This start-up sheet covers all startup check points common to all package equipment. In addition it covers essential startup check points for a number of common installation options. Depending upon the particular unit being started not all sections of this startup sheet will apply. Complete those sections applicable and use the notes section to record any additional information pertinent to your particular installation.

Warranty claims are to be made through the distributor from whom the equipment was purchased.

### EQUIPMENT STARTUP

**Use the local LCD or Mobile Access Portal (MAP) Gateway to complete the start-up.**

**A copy of the completed start-up sheet should be kept on file by the distributor providing the equipment and a copy sent to:**

Johnson Controls/UPG  
 Technical Services Department  
 5005 York Drive  
 Norman, OK 73069

**SAFETY WARNINGS**

The inspections and recording of data outlined in this procedure are required for start-up of Johnson Controls/UPG's packaged products. Industry recognized safety standards and practices must be observed at all times. General industry knowledge and experience are required to assure technician safety. It is the responsibility of the technician to assess all potential dangers and take all steps warranted to perform the work in a safe manner. By addressing those potential dangers, prior to beginning any work, the technician can perform the work in a safe manner with minimal risk of injury.

 <b>WARNING</b>
Lethal voltages are present during some start-up checks. Extreme caution must be used at all times.

 <b>WARNING</b>
Moving parts may be exposed during some startup checks. Extreme caution must be used at all times.

**NOTE:** Read and review this entire document before beginning any of the startup procedures.

**DESIGN APPLICATION INFORMATION**

This information will be available from the specifying engineer who selected the equipment. If the system is a VAV system the CFM will be the airflow when the remote VAV boxes are in the

full open position and the frequency drive is operating at 60 HZ. **Do not proceed with the equipment start-up without the design CFM information.**

Design Supply Air CFM: \_\_\_\_\_ Design Return Air CFM: \_\_\_\_\_

Design Outdoor Air CFM At Minimum Position: \_\_\_\_\_

Total External Static Pressure: \_\_\_\_\_

Supply Static Pressure: \_\_\_\_\_

Return Static Pressure: \_\_\_\_\_

Design Building Static Pressure: \_\_\_\_\_

Outside Air Dilution: Economizer Position Percentage: \_\_\_\_\_ CFM: \_\_\_\_\_

Supply Gas Pressure After Regulator W/o Heat Active \_\_\_\_\_ Inches \_\_\_\_\_

ADDITIONAL APPLICATION NOTES FROM SPECIFYING ENGINEER:

## REFERENCE

General Inspection	Completed	See Notes
Unit inspected for shipping, storage, or rigging damage	<input type="checkbox"/>	<input type="checkbox"/>
Unit installed with proper clearances	<input type="checkbox"/>	<input type="checkbox"/>
Unit installed within slope limitations	<input type="checkbox"/>	<input type="checkbox"/>
Refrigeration system checked for gross leaks (presence of oil)	<input type="checkbox"/>	<input type="checkbox"/>
Terminal screws and wiring connections checked for tightness	<input type="checkbox"/>	<input type="checkbox"/>
Filters installed correctly and clean	<input type="checkbox"/>	<input type="checkbox"/>
Economizer hoods installed in operating position	<input type="checkbox"/>	<input type="checkbox"/>
Condensate drain trapped properly, refer to Installation Manual	<input type="checkbox"/>	<input type="checkbox"/>
Economizer damper linkage tight	<input type="checkbox"/>	<input type="checkbox"/>
Gas Heat vent hood installed	<input type="checkbox"/>	<input type="checkbox"/>
All field wiring (power and control) complete	<input type="checkbox"/>	<input type="checkbox"/>

Air Moving Inspection	Completed	See Notes
Alignment of drive components	<input type="checkbox"/>	<input type="checkbox"/>
Belt tension adjusted properly	<input type="checkbox"/>	<input type="checkbox"/>
Blower pulleys tight on shaft, bearing set screws tight, wheel tight to shaft	<input type="checkbox"/>	<input type="checkbox"/>
Pressure switch or transducer tubing installed properly	<input type="checkbox"/>	<input type="checkbox"/>

Exhaust Inspection	Powered <input type="checkbox"/>	Barometric Relief <input type="checkbox"/>	Completed	See Notes
Check hub for tightness			<input type="checkbox"/>	<input type="checkbox"/>
Check fan blade for clearance			<input type="checkbox"/>	<input type="checkbox"/>
Check for proper rotation			<input type="checkbox"/>	<input type="checkbox"/>
Check for proper mounting (screen faces towards unit)			<input type="checkbox"/>	<input type="checkbox"/>
Prove operation by increasing minimum setting on economizer			<input type="checkbox"/>	<input type="checkbox"/>

Economizer Inspection	Standard <input type="checkbox"/>	BAS <input type="checkbox"/>	Completed	See Notes
CO <sub>2</sub> sensor installed Yes <input type="checkbox"/> No <input type="checkbox"/>			<input type="checkbox"/>	<input type="checkbox"/>
Check economizer setting (Reference SSE Control Board LCD menu location)			<input type="checkbox"/>	<input type="checkbox"/>
Prove economizer open/close through SSE Board Setting			<input type="checkbox"/>	<input type="checkbox"/>

Reheat Mode	Normal <input type="checkbox"/>	or Alternate <input type="checkbox"/>	Not Applicable <input type="checkbox"/>
Humidity Sensor (2SH0401) _____			

### Operating Measurements - Air Flow

Fan operates with proper rotation	ID Fans <input type="checkbox"/>	Exh. Fans <input type="checkbox"/>	Cond. Fans <input type="checkbox"/>
Pressure drop across dry evaporator coil (At maximum design CFM) <sup>1</sup>			IWC
External Static Pressure			IWC
Return Static Pressure			IWC
Supply Static Pressure			IWC
Supply Air CFM Using Dry Coil Chart			CFM
Final Adjusted Supply Air CFM <sup>2</sup>			CFM

1. Consult the proper airflow to pressure drop table to obtain the actual airflow at the measured pressure differential.
2. Was a motor pulley adjustment or change required to obtain the correct airflow?  
 Was it necessary to increase or decrease the airflow to meet the design conditions?  
 If the motor pulley size was changed, measure the outside diameters of the motor and blower pulleys and record those diameters here:  
 Blower Motor HP \_\_\_\_\_ FLA \_\_\_\_\_ RPM \_\_\_\_\_  
 Pulley Pitch Diameter \_\_\_\_\_ Turns Out \_\_\_\_\_ Final Turns Out \_\_\_\_\_  
 Blower Pulley Pitch Diameter \_\_\_\_\_ Fixed Sheave \_\_\_\_\_

### ELECTRICAL DATA

T1 - T2 \_\_\_\_\_ Volts                      T2 - T3 \_\_\_\_\_ Volts  
 Control Voltage \_\_\_\_\_ Volts                      T1 - T3 \_\_\_\_\_ Volts

Device	Nameplate	Measured List All Three Amperages
Supply Fan Motor <sup>1, 2</sup>	AMPS	AMPS
Exhaust Motor (Dampers 100%)	AMPS	AMPS
Condenser Fan #1	AMPS	AMPS
Condenser Fan #2 (if equipped)	AMPS	AMPS
Condenser Fan #3 (if equipped)	AMPS	AMPS
Condenser Fan #4 (if equipped)	AMPS	AMPS
Compressor #1	AMPS	AMPS
Compressor #2 (if equipped)	AMPS	AMPS
Compressor #3 (if equipped)	AMPS	AMPS
Compressor #4 (if equipped)	AMPS	AMPS

1. VAV units with heat section - simulate heat call to drive VAV boxes and VFD/IGV to maximum design airflow position.
2. VAV units without heat section - VAV boxes must be set to maximum design airflow position.



