

HABEGGER

Fabrication Division

925 Redna Terrace, Cincinnati, Ohio 45215

(513) 761-0383/1293 (Fax)

Submittals

Prepared By: Habegger Fabrication Division
925 Redna Terrace
Cincinnati, Ohio, 45215
Chalk Fry III

Contractor: **Champion Commercial Service**

Job: Bodybar- Centerville

Date: 6/13/2025

Submittal Table of Contents

Broan Submittal

LIGHT COMMERCIAL ENERGY STAR® CERTIFIED CEILING MOUNT VENTILATORS MODELS L100E, L150E, L200E, L250E & L300E

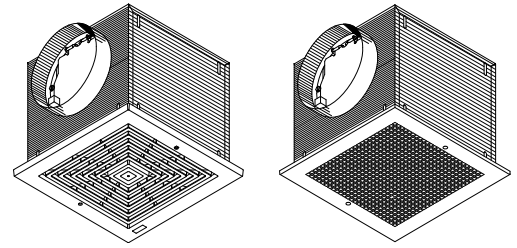

Incredibly reliable. Unbelievably quiet. Offering the CFM choices you need at the lowest sound levels in the industry.

FEATURES

GRILLE:

- Conceals interior
- Low profile styling blends with any decor
- White plastic (optional metal grille, finished with white enamel paint is available - Model MG1)

BLOWER:

- Low RPM for quiet operation
- Resilient anti-vibration mounts
- Dynamically-balanced, centrifugal blower wheel for quiet, efficient performance
- Permanently lubricated, thermally protected motor
- Plug-in motor rated at 120 VAC
- Designed for continuous operation

HOUSING:

- Rugged, 20 gauge galvanized steel
- 8" round duct connector
- 1/2" acoustic insulation inside
- Not for use in a cooking area
- May be installed in ceiling or wall (size permitting)
- 8-position mounting brackets for easy installation and greater adaptability to various mounting requirements
- Automatic backdraft damper located within duct connector
- Factory-shipped in horizontal discharge position - easily converted to vertical discharge

ACCESSORIES (available separately):

- Model MG1 Metal Grille Cover Upgrade
- Model RD1 Radiation Damper
- Model 80L Electronic Speed Control (Internal)

TYPICAL SPECIFICATION

Ventilator shall be Broan Model L100E, (L150E), (L200E), (L250E), (L300E).

Ventilator shall have galvanized steel housing insulated with at least 1/2" of acoustic insulation. Housing to have adjustable mounting brackets.

Automatic backdraft damper to be located within duct connector. Duct connector, blower assembly, and wiring plate shall be adjustable for either horizontal or vertical installation.

Blower unit shall be removable from housing and shall have a dynamically balanced centrifugal-type blower wheel. Motor to be permanently lubricated and mounted with resilient anti-vibration mounts.

Air delivery shall be no less and sound levels no greater than listed for each model. All air and sound ratings shall be certified by AMCA and HVI. Units to be cULus Listed.



Broan-NuTone LLC, 926 West State Street, Hartford, Wisconsin, USA 53027 Broan-NuTone.com 800-558-1711
 Venmar Ventilation ULC, 550 Lemire Blvd., Drummondville, Québec, Canada J2C 7W9 Broan-NuTone.ca 800-567-3855

REFERENCE	QTY.	REMARKS	Project	
EF-1-3	3	L100E	Location	
			Architect	
			Engineer	
			Contractor	
			Submitted by	Date

PERFORMANCE RATINGS - LIGHT COMMERCIAL ENERGY STAR® CERTIFIED CEILING MOUNT VENTILATORS L100E, L150E, L200E, L250E & L300E

AMCA LICENSED PERFORMANCE

MODEL NO.		STATIC PRESSURE (Inches water gage)								NOMINAL RPM	MAX. AMPS @60 Hz	AC VOLTS	
		0.0	0.1	0.125	0.25	0.375	0.5	0.625	0.75				0.875
L100E	CFM Hor.	164	138	132	103	74	40				803	0.3	120
	SONES Hor.	0.2	0.3		0.7								
L100E	CFM Ver.	168	138	131	101	73	38				799	0.3	120
	SONES Ver.	0.1	0.2		0.8								
L150E	CFM Hor.	238	214	209	183	154	122	77			972	0.4	120
	SONES Hor.	1.0	1.0		1.1								
L150E	CFM Ver.	224	203	198	174	146	105	64			990	0.4	120
	SONES Ver.	0.9	0.9		1.0								
L200E	CFM Hor.	267	246	240	214	184	155	109	56		1031	0.5	120
	SONES Hor.	1.5	1.5		1.7								
L200E	CFM Ver.	253	233	228	202	172	123	87	41		1063	0.5	120
	SONES Ver.	1.4	1.3		1.5								
L250E	CFM Hor.	296	277	272	249	223	195	160	108	51	1128	0.6	120
	SONES Hor.	1.9	1.9		1.8								
L250E	CFM Ver.	280	263	259	237	212	185	142	89	40	1144	0.6	120
	SONES Ver.	1.9	1.8		1.8								
L300E	CFM Hor.	343	324	319	295	268	237	204	162	89	1189	0.7	120
	SONES Hor.	3.0	2.9		2.7								
L300E	CFM Ver.	334	315	311	286	258	227	189	150	20	1207	0.7	120
	SONES Ver.	2.9	2.7		2.6								

Performance ratings including the effects of inlet grille and backdraft damper in the airstream. Speed (RPM) shown is nominal. Performance is based on actual speed test. The sound ratings shown are tested to 1/3 octave, Spherical Sones to AMCA 300. Values shown are for installation Type B: Free inlet fan sone levels. Performance shown is for Installation Type B: Unducted inlet, Ducted outlet.

HVI PERFORMANCE

MODEL NO.	Ducting	0.1" Ps			0.25" Ps	
		CFM	Sones	CFM/Watt	CFM	Sones
L100E	Horizontal	130	0.3	4.9	97	0.8
	Vertical	140	0.3	5.3	101	0.6
L150E	Horizontal	200	1.0	4.6	168	1.4
	Vertical	210	0.7	4.9	178	1.0
L200E	Horizontal	230	1.3	4.4	198	1.5
	Vertical	240	1.0	4.6	209	1.3
L250E	Horizontal	270	1.5	4.5	242	2.0
	Vertical	270	1.4	4.5	242	1.5
L300E	Horizontal	310	2.5	4.2	281	2.5
	Vertical	310	2.5	4.3	282	2.5



Broan-NuTone LLC certifies that the models shown herein are licensed to bear the AMCA Seal. The ratings shown are based on tests and procedures performed in accordance with AMCA Publication 211 (and AMCA Publication 311 if sound is also certified) and comply with the requirements of the AMCA Certified Ratings Program.



All models are UL Listed for use over bathtubs and showers when connected to a GFCI-protected branch circuit (ceiling mount only).



HVI-2100 CERTIFIED RATINGS comply with new testing technologies and procedures prescribed by the Home Ventilating Institute, for off-the-shelf products, as they are available to consumers. Product performance is rated at 0.1 in. static pressure, based on tests conducted in a state-of-the-art test laboratory. Sones are a measure of humanly-perceived loudness, based on laboratory measurements.

WEIGHT

MODEL NO.	SHIPPING WT.
L100E	18.9 lb.
L150E	19.3 lb.
L200E	19.1 lb.
L250E	21.0 lb.
L300E	21.2 lb.



Broan-NuTone LLC, 926 West State Street, Hartford, Wisconsin, USA 53027 Broan-NuTone.com 800-558-1711
Venmar Ventilation ULC, 550 Lemire Blvd., Drummondville, Québec, Canada J2C 7W9 Broan-Nutone.ca 800-567-3855

PERFORMANCE CURVES - LIGHT COMMERCIAL ENERGY STAR® CERTIFIED CEILING MOUNT VENTILATORS

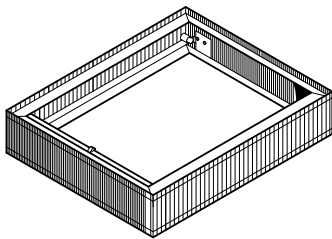
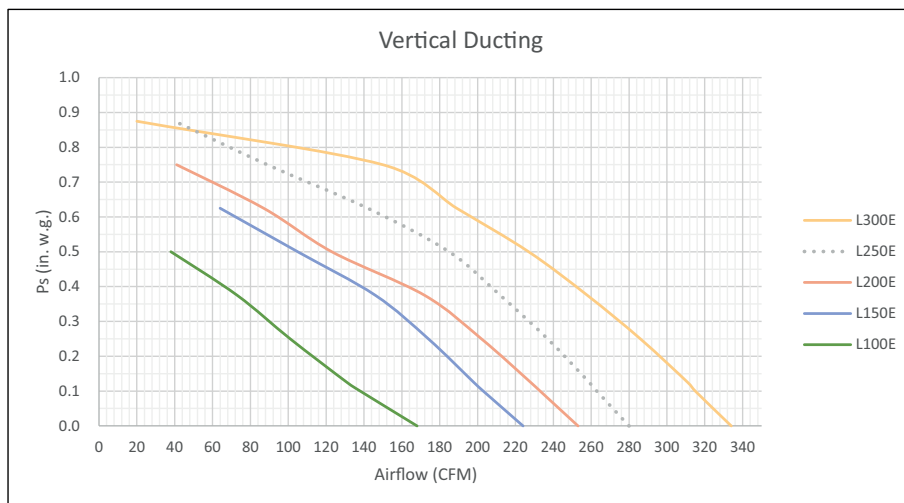
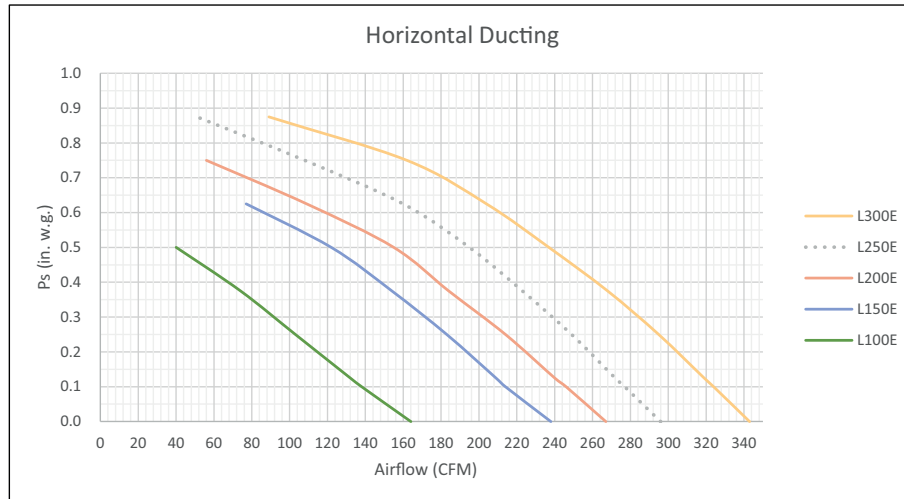

**RADIATION DAMPER
MODEL RD1
(AVAILABLE SEPARATELY)**

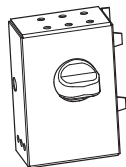

**ELECTRONIC SPEED
CONTROL (INTERNAL)
MODEL 80L
(AVAILABLE SEPARATELY)**

8-in. ROUND
DUCT
CONNECTOR

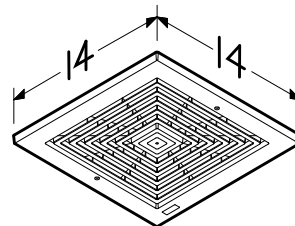
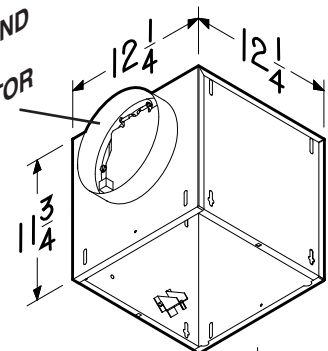

**PLASTIC GRILLE
(included with
all models)**

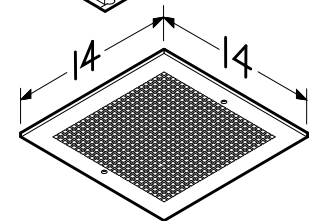

**OPTIONAL
METAL GRILLE
MODEL MG1
(available separately)**

NOTE: Dimensions shown are in inches.

