

Start-Up

Service

**Equipment with Start-Up**

Name	Equipment Type
DOAS-2 (Kitchen)	ERV
DOAS-1 (Dining)	ERV

Start-Up and Test & Balance to be performed by National TAB

# XRV-25-15J-J-G1

## Unit Performance

Design Conditions							
Elevation (ft)	Summer		Winter DB (F)	Supply (CFM)	Outdoor Air (CFM)	Recirc Air (CFM)	Exhaust Air (CFM)
	DB (F)	WB (F)					
866	89.0	75.0	-25.0	6,150	1,750	4,400	-

Unit Specifications						
Qty	Weight (lb)	Cooling Type	Heating Type	Unit Installation	Unit ETL Listing	Furnace ETL Listing
1	2,459 (+/- 5%)	Packaged DX	Indirect Gas	Outdoor	UL/cUL 1995	ANSI Z83.8 / CSA 2.6

Configuration				
Outdoor Air			Exhaust Air	
Intake	Discharge		Intake	Discharge
End	Bottom		Bottom	End

ASHRAE 90.1-2019 Compliance			
	ASHRAE 90.1 Min. Efficiency	Calculated Efficiency	Compliance
EER	10.8	10.8	✓
IEER	12.2	18.8	✓

Cooling Specifications							
Type	Total Capacity (MBH)	Sensible Capacity (MBH)	Lead Compressor Type	Coil (DB/WB)		Reheat	
				EAT (F)	LAT (F)	Capacity (MBH)	LAT (F)
Packaged DX	207.7	153.5	Inverter Scroll	79.0 / 66.5	56.2 / 56.0	151.7	79.1

Heating Specifications								
Type	Gas Type	Input (MBH)	Output (MBH)	Temperature Rise		Turndown	Performance	
				Min (F)	Max (F)		EAT (F)	LAT (F)
Indirect Gas	Natural	300.0	240.0	9.0	36.0	4:1	44.4	80.5

Air Performance							
Type	Total Volume (CFM)	External SP (in. wg)	Total SP (in. wg)	FRPM	Fan		
					Qty	Type	Drive-Type
Supply	6,150	0.75	3.949	2747	1	Plenum	Direct

Motor Specifications						
Motor	Qty	Operating Power (hp)	Size (hp)	Enclosure	Efficiency	RPM
Supply	1	7.1	10	ODP	PE	1770

Electrical Specifications				
Power Supply	Rating (V/C/P)	MCA (A)	MOP (A)	Fan Power (W/CFM)*
Unit	208/60/3	102.8	150.0	0.860

\*Fan Power (W/CFM) = (Supply BHP + Exhaust BHP) / Supply CFM

### Construction Features And Accessories

Unit	
Unit Installation - Outdoor	Std
Unit Construction - Double Wall	Std
Insulation - 2 inch 2.4# R13 foam	Std
Corrosion Resistant Fasteners	Std
Hinged Access	Std
Factory Wired Non-Fused Disconnect Switch	X
Direct Drive Plenum Blower & Motor Assemblies	X
Factory Wired VFDs	Std
Unit Finish - Permatector, Concrete Gray (RAL 7023)	X
Stainless Steel Condensate Drain Pan and Connection	Std
Condensate Drain Trap	Std
Short Circuit Current - 5 kA	Std
Controls	
Unit Controls - Full Control	Std
Internally Mounted Control Center with 24 VAC control transformer(s) and control circuiting fusing	Std
BMS Protocol - None	
BMS Monitoring Points	
Supply Fan Control - Single Zone VAV	X
Exhaust Fan Control	
Exhaust Fan Only Power	
Energy Wheel Rotation Sensor	
Web-Based User Interface	Std
Outd/Rec. Air Damper Ctrl - Constant Position-Adj. Setpoint	X
Economizer Control Temp./Enthalpy	X
Furnace Control - 4:1 Modulating	X
Control Accessories	
Remote Display - w/150 ft cord	X
Dirty Filter Sensor(s) - Supply	X
Airflow Monitor	
Room Thermostat - Temp and RH	X
Phase/Brownout Protection	Std
Economizer Fault Detection Diagnostics	X

Accessories	
Recirc Air Damper - Low Leakage	X
Outdoor Air Damper - Low Leakage	X
Return Air Damper	
Roof Curb - GKD - 45.9/91.9-G14	X
Supply Air Filters - 2" Merv 13, 2-20x22x2, 2-20x24x2	X
Service Outlet - Factory mounted and wired	X
Piping Vestibule	
Service Lights	
Condensate Overflow Switch	X
Spare Filters	
Exhaust Discharge Gravity Backdraft Damper	
ElectroFin Coil Coating	
Motor Shaft Grounding	
UV Lights	
Bipolar Ionization	
Smoke Detector(s), Exhaust - Shipped Loose	X
Barometric Relief Damper	X
Energy Core Bypass Damper	
Power Venting	Std
Hail Guards	X
Warranty Options	
Unit Warranty - 18 Months (Std.)	Std
Compressor Warranty - 18 Months (Std.)	Std
Furnace HX Warranty - 25 Yrs.	Std

Standard Option	Std
Not Included	
Included	X

**Notes**  
 Outdoor Air Damper supplied is low leakage, motorized VCD-23 (leakage rate of 3 CFM / ft<sup>2</sup> @ 1 in. wg), Class 1A

## Special Design Requests

Special Design Number
Special Design Request for "OA - Building Pressure Control", (E1234567)

## Supply Fan Charts And Performance

Supply Fan Performance									
Total Volume (CFM)	External SP (in. wg)	Total SP (in. wg)	RPM	Operating Power (hp)	Motor		Fan		
					Qty	Size (hp)	Qty	Type	Drive-Type
6,150	0.75	3.949	2747	7.1	1	10	1	Plenum	Direct

Pressure Drop (in. wg)						
Weatherhood	Filter	Damper	Cooling	Heating	External	Total
0.02	0.864	0.14	0.745	0.828	0.75	3.949

Sound Performance in Accordance with AMCA										
Sound Power by Octave Band								Lwa	dBA	Sones
62.5	125	250	500	1000	2000	4000	8000			
86	85	97	86	82	76	79	70	91	79	31

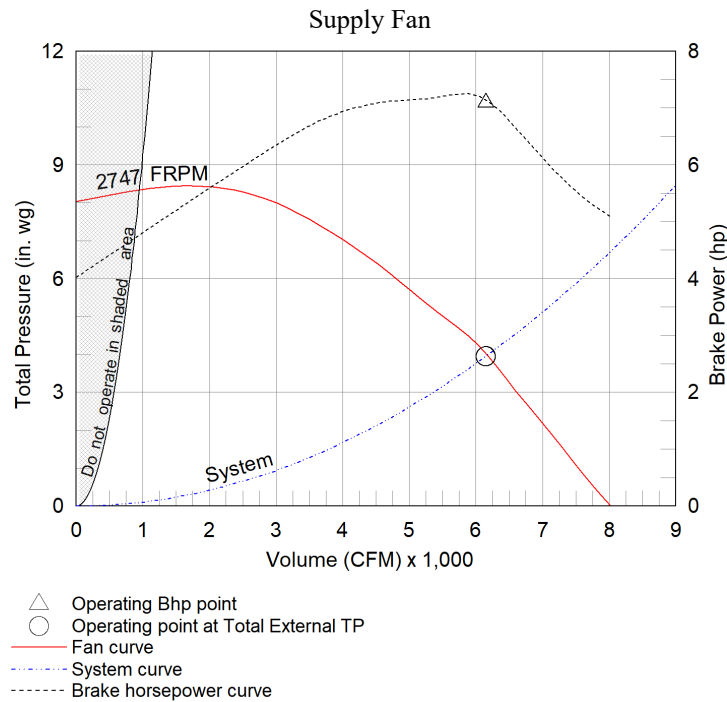

## Radiated Sound

### Position A

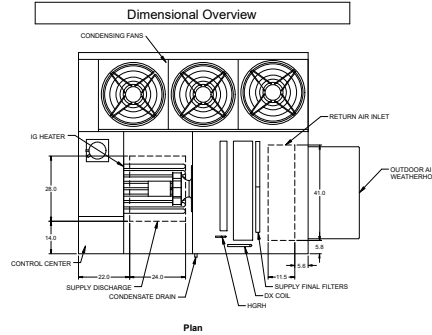

Position D

Position B

Position C

"E" is the  
Top Plane

Supply Air Flow Nominal, Largest Tonnage Condensing Section Available, PDX units only

Radiated Sound Levels										
Plane	Octave Bands (Lw)								Plane Lw	Plane LwA
	1	2	3	4	5	6	7	8		
A	73	85	78	80	81	73	67	62	88	83
B	71	79	69	78	73	68	64	57	83	78
C	79	77	69	76	75	70	60	59	83	78
D	74	77	72	74	74	67	61	58	82	77
E	77	84	78	79	77	72	65	61	87	81
<b>Total</b>	83	89	82	85	84	78	71	67	93	87

AMCA 320-07 - Laboratory Methods of Sound Testing of Fans Using Sound Intensity
Tests conducted in accordance with this standard.
Free field measurement plane created 1 foot from unit on all sides and top.
Sound Intensity measured in Watts/m <sup>2</sup> .
Sound data converted to Sound Power (Lw) for the chart above.
A-Weighted Sound Power was determined using AMCA Standard 301-90 Clause 9.1.
Plane E sound data was measured above the top plane of the unit.

### Cooling Performance

Cooling Specifications									
Nominal Tonnage	Entering Air (F)		Leaving Air (F)		Capacity (MBH)		Reheat		Condensing Ambient Temp (F)
	DB	WB	DB	WB	Total	Sensible	Capacity (MBH)	LAT (F)	
15.0	79.0	66.5	56.2	56.0	207.7	153.5	151.7	79.1	89.0

Coil Information									
PDX Coil Model	Fins Per Inch	Rows Deep	Face Vel. (ft/min)	Coil PD (in. wg)	Refrigerant	Refrig. Velocity (ft/min)	Face Area (ft2)	Suction Temp (F)	
DR516L06S14-45X42.5-LH	14	6	463	0.745	R-410A	1,485	13.3	48.8	

Compressor Details					
Lead Compressor Type	Compressor Qty	Compressor RLA/MRC (A)		Compressor LRA (A)	
		Comp. #1	Comp. #2	Comp. #1	Comp. #2
Inverter Scroll	1	51.3	-	NA	-

Unit Details
Refrigerant charges provided by the factory are approximate and may require adjustment in the field
Hermetic scroll type compressors
Compressors mounted on neoprene vibration isolation
Stainless steel double sloped drain pan
Moisture-indicating sight glass
Service/charging valves
Refrigerant high pressure switch (manual reset)
Liquid-Line filter drier
All condenser fans will have EC motors and will modulate in sync to maintain a head pressure set point.
Inverter scroll compressor
Electronic expansion valve

### Heating Performance

Heating Specifications								
Type	Gas Type	Input (MBH)	Output (MBH)	Temperature Rise		Turndown	Performance	
				Min (F)	Max (F)		EAT (F)	LAT (F)
Indirect Gas	Natural	300.0	240.0	9.0	36.0	4:1	44.4	80.5

Unit Details
ANSI standard Z83.8 and CSA 2.6
High Thermal efficiency
Direct spark ignition
3/4" Gas Connection
At least 6 in. wg of natural gas pressure (14 in. wg for LP) is required at the units gas connection in order to achieve maximum performance
Power Venting
24 Volt Control Power
Stainless Steel heat exchange tubes
Unit controller maximum allowable supply discharge air set point is 100F (37.8C)

## Isometric Drawings

Component Layout

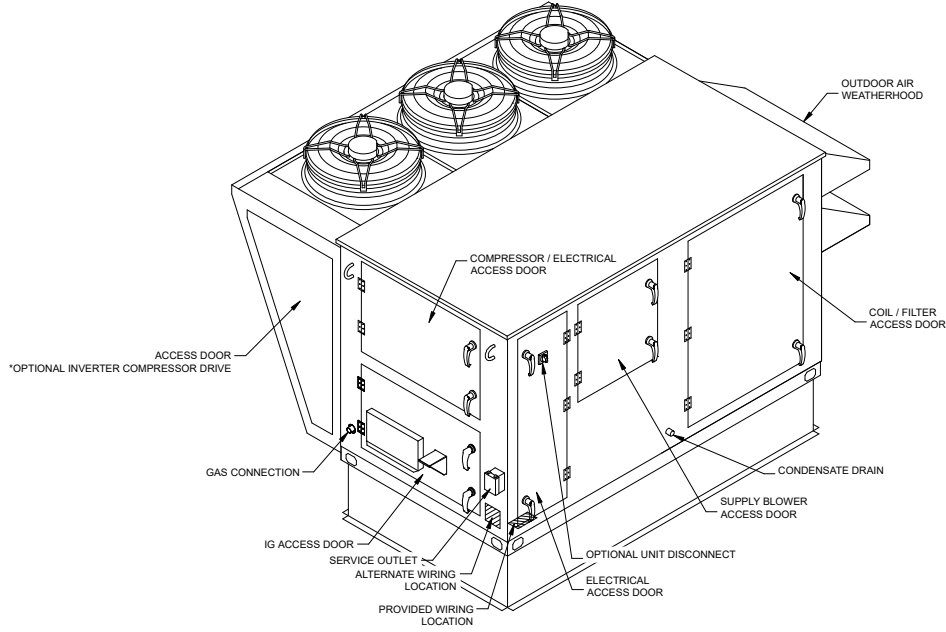

Back Right Isometric

Service Clearances

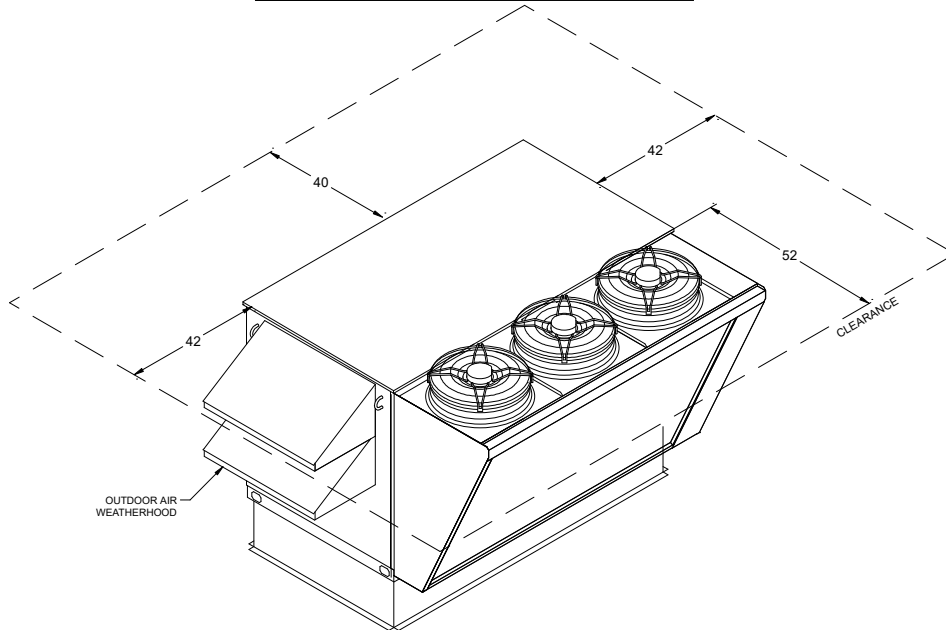

Front Left Isometric

## Overview Drawings

### Dimensional Overview

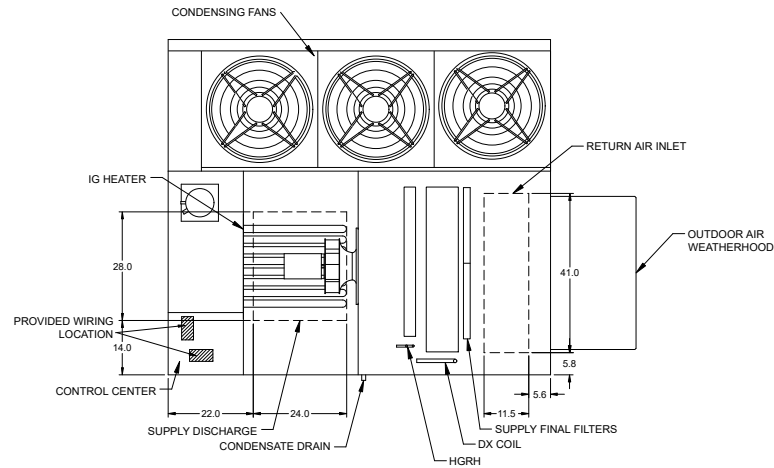
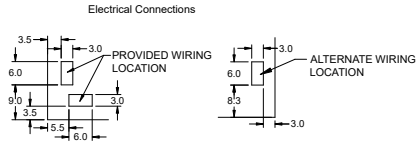

Plan

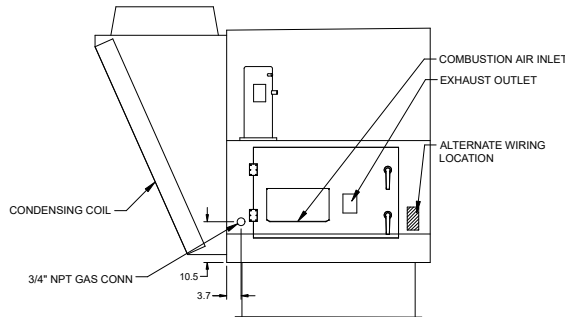

Left End

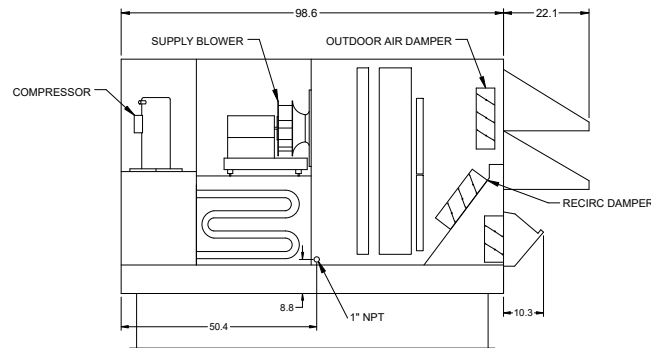

Elevation

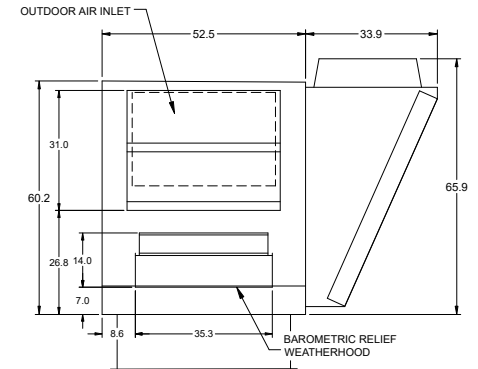

Right End

**Unit Corner Weights**

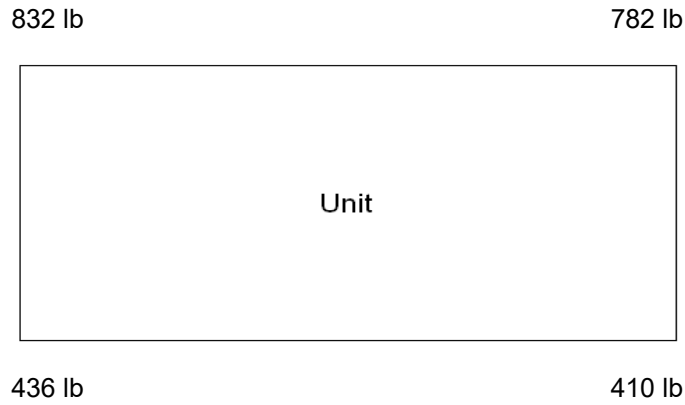

**Note**

Estimated corner weights are shown looking down on unit and the outside air intake will be on the right. Weights are applied at the base of the unit. Images not drawn to scale.

## Wiring Diagram

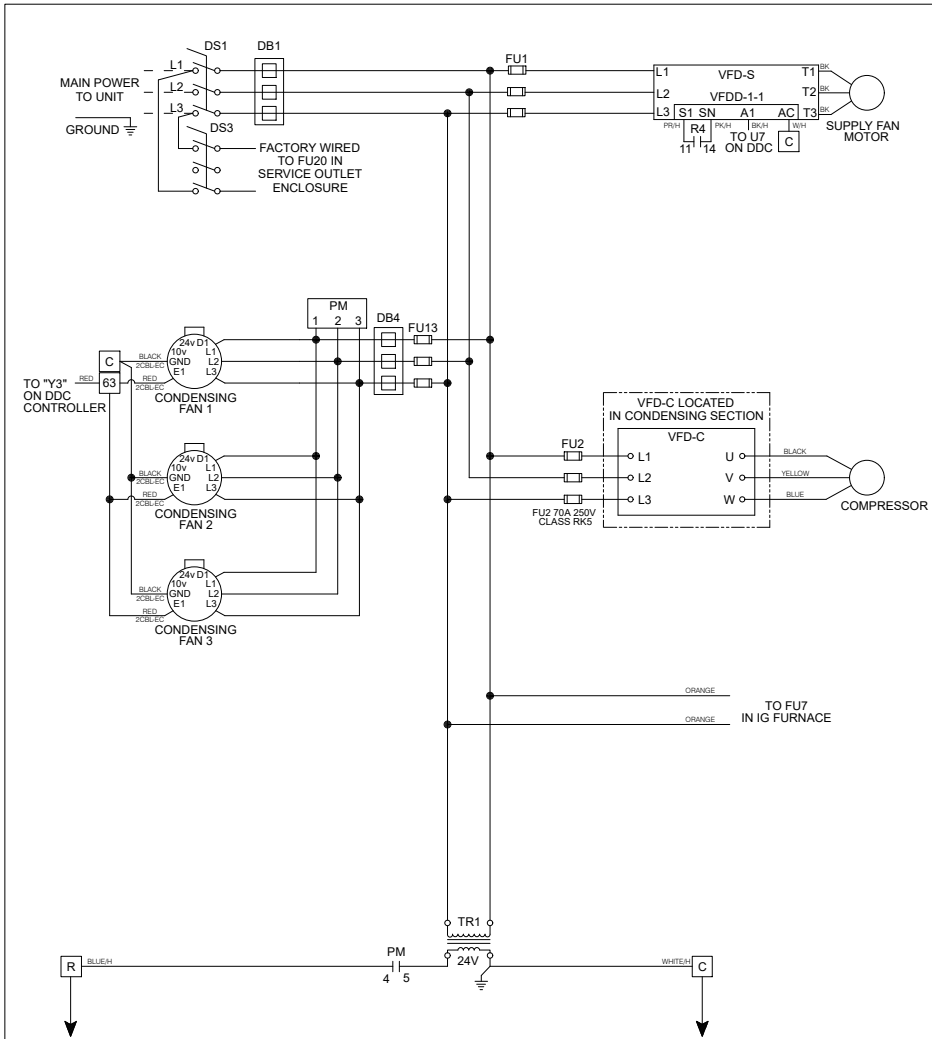

Wiring Diagram Code:  
**A12E2F0XP40C05X00HN33G0600XH27**

**CAUTION**  
 UNIT SHALL BE GROUNDED IN ACCORDANCE WITH N.E.C.  
 POWER MUST BE OFF WHILE SERVICING.

**NOTES**  
 USE COPPER CONDUCTORS ONLY  
 60° C FOR TERMINALS RATED LESS THAN 100 AMPS.  
 75° C FOR TERMINALS RATED 100 AMPS OR MORE.  
 FIELD CONTROL WIRING RESISTANCE SHOULD NOT EXCEED 0.75 OHM.  
 FIELD WIRED - - - - -  
 FACTORY SUPPLIED AND WIRED \_\_\_\_\_

**WIRE COLOR CODE**

BK	BLACK	BL	BLUE	BR	BROWN
GY	GRAY	LT BL	LIGHT BLUE	O	ORANGE
PK	PINK	PR	PURPLE	R	RED
W	WHITE	Y	YELLOW		

**LEGEND**

- DB# POWER DISTRIBUTION BLOCK
- DS DISCONNECT SWITCH
- FU# FUSES
- PM PHASE VOLTAGE MONITOR
- R4 SUPPLY BLOWER VFD RELAY
- TR# TRANSFORMER
- VFD VARIABLE FREQUENCY DRIVE

## Wiring Diagram 2

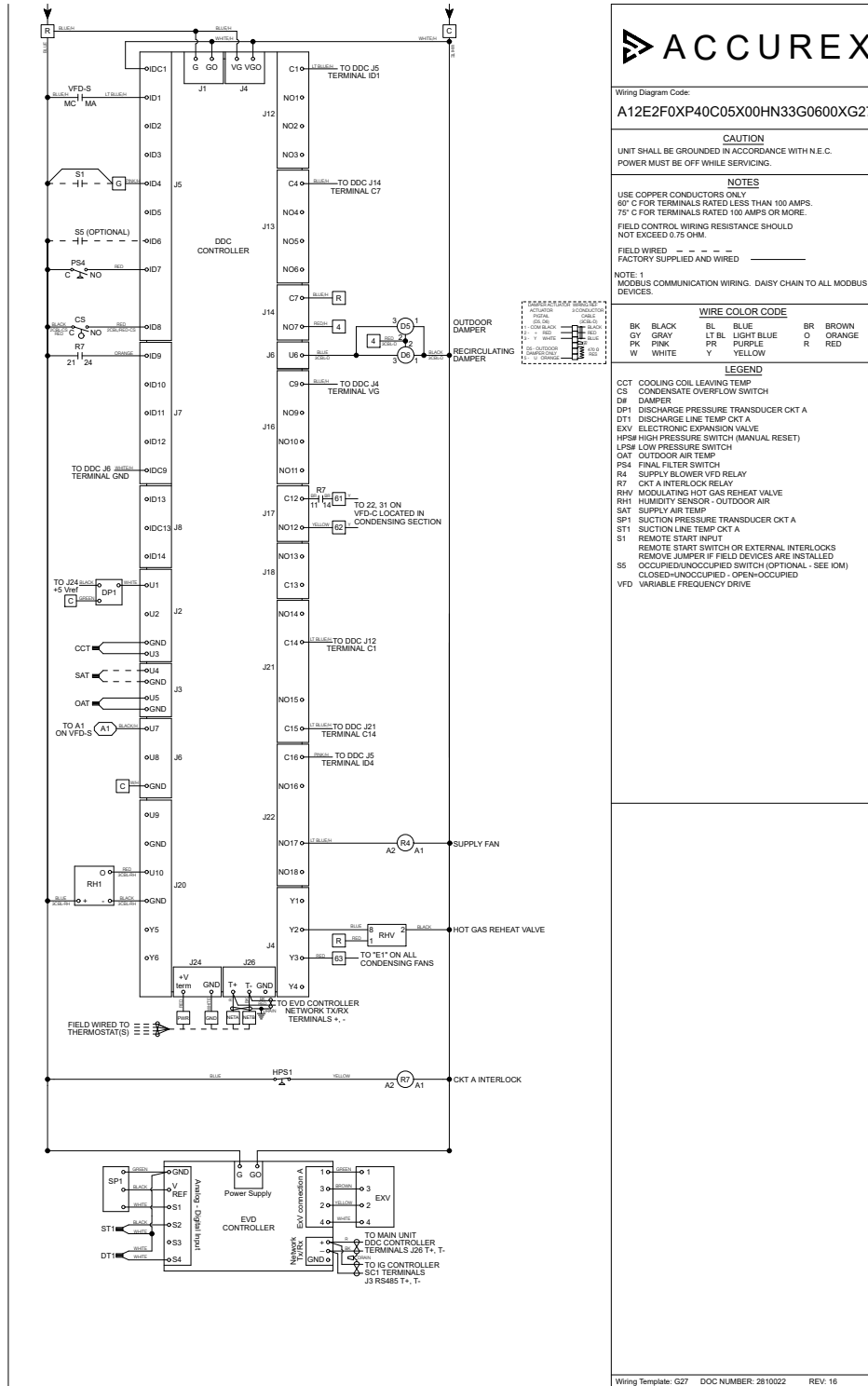

## Wiring Diagram 3

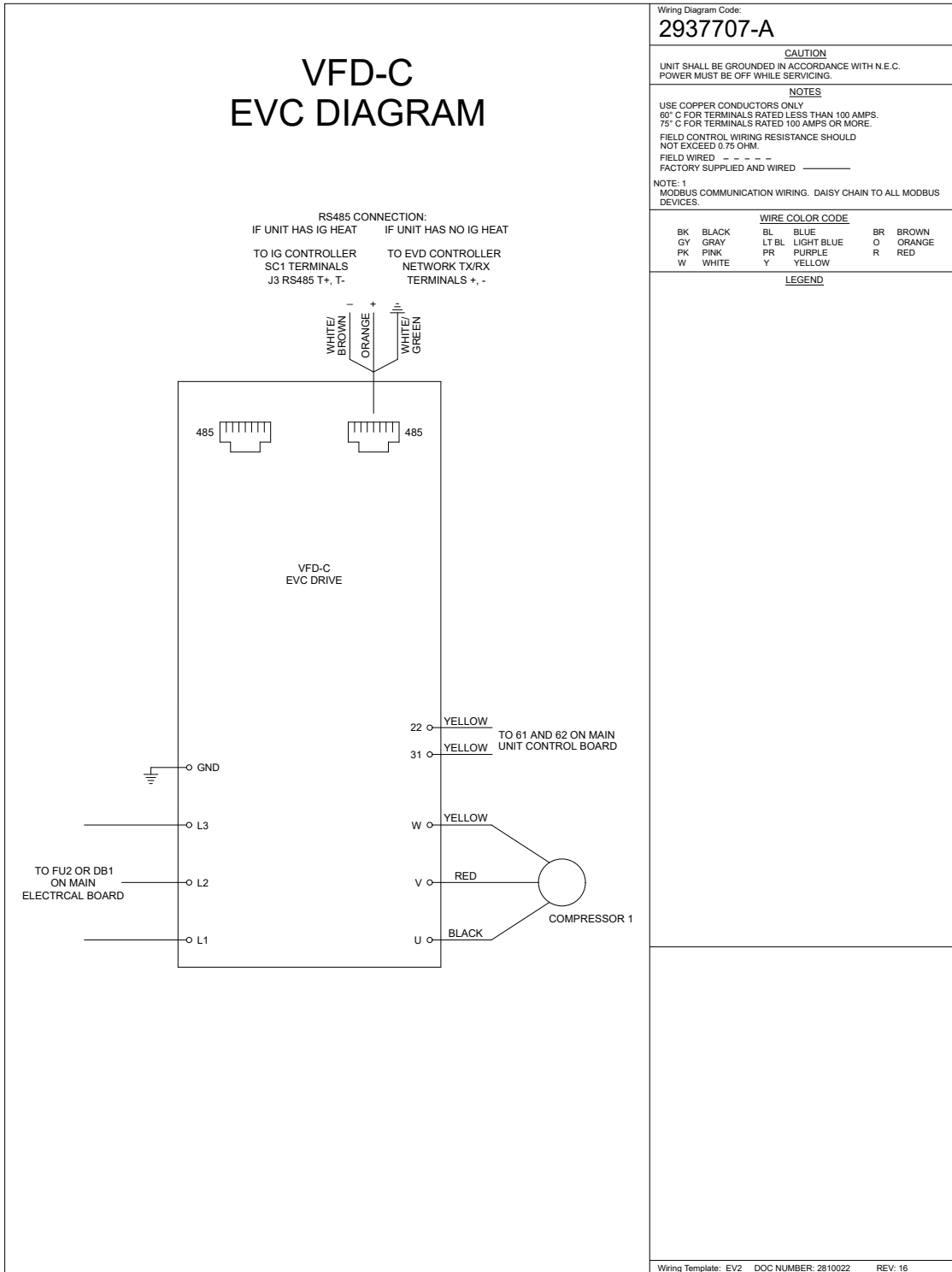

## INDIRECT GAS WIRING DIAGRAM FURNACE 1 - 4:1 MODULATING

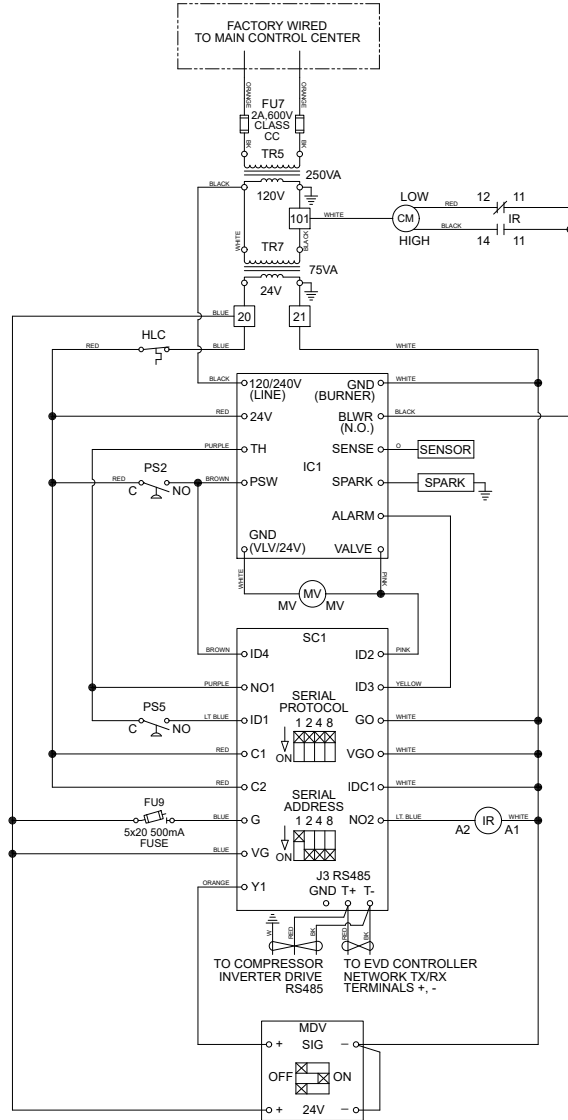

## ACCUREX

Wiring Diagram Code:

**A4K51P1RX0052GS20**

**CAUTION**

UNIT SHALL BE GROUNDED IN ACCORDANCE WITH N.E.C.  
 POWER MUST BE OFF WHILE SERVICING.

**NOTES**

USE COPPER CONDUCTORS ONLY  
 60° C FOR TERMINALS RATED LESS THAN 100 AMPS.  
 75° C FOR TERMINALS RATED 100 AMPS OR MORE.  
 FIELD CONTROL WIRING RESISTANCE SHOULD  
 NOT EXCEED 0.75 OHM.

FIELD WIRED - - - - -  
 FACTORY SUPPLIED AND WIRED \_\_\_\_\_

NOTE: 1  
 MODBUS COMMUNICATION WIRING. DAISY CHAIN TO  
 ALL MODBUS DEVICES.

**WIRE COLOR CODE**

BK	BLACK	BL	BLUE	BR	BROWN
GY	GRAY	LT BL	LIGHT BLUE	O	ORANGE
PK	PINK	PR	PURPLE	R	RED
W	WHITE	Y	YELLOW		

**LEGEND**

CM	COMBUSTION BLOWER MOTOR
FU#	FUSE(S)
HLC	HIGH TEMPERATURE LIMIT CONTROL
IC1	IGNITION CONTROL
IR	INDUCTION RELAY
MDV	MODULATING VALVE
MV	MAIN GAS VALVE
PS2	COMBUSTION AIR PROVING SWITCH
PSS	HIGH SPEED PRESSURE SWITCH
SC1	STAGE CONTROLLER
TR#	TRANSFORMER(S)

## Factory Controller Sequence of Operation

**FACTORY CONTROLLER:** Controller shall be provided with required sensors and programming for rooftop unit. Controller shall be factory programmed, mounted and tested. Controller shall have a LCD readout for changing set points and monitoring unit operation.

**UNIT START COMMAND (Unit will be enabled to start once a jumper is placed between R to G):**

- Factory mounted and wired outdoor air and recirculated air damper actuators are powered.
- Supply fan starts after after a (adj.) delay.
- Tempering options to function as described below.

**UNIT STOP COMMAND (OR DE-ENERGIZED):**

- Supply fan, exhaust fan and tempering options de-energized.
- Outdoor air damper actuator is spring return close, and the recirculated air damper actuator is spring open.

**OCCUPIED/UNOCCUPIED MODES:** Shall be based on a 7-day time clock internal to the controller. The schedule shall be set by the end user. When a user initiates an override input, the controller will switch from unoccupied to occupied mode. The controller will return to the scheduled occupied/unoccupied mode after the override time has expired. If internal time clock is disabled, a remote contact or a BMS can control the occupied/unoccupied mode.

**Occupied Mode:**

- Damper control per below.
- Supply fan ON.
- Heating per below.
- Cooling per below.

**Unoccupied mode (Cycle on Room Temp):**The unit will cycle to maintain unoccupied room set points if there is a call for unoccupied heating, cooling or dehumidification.

- Supply fan OFF
- Recirculation air damper open.
- Outdoor air damper closed.
- On a call for heating (room temp set point – differential) supply fan cycles ON, and the heating increases the room temperature. Unit cycles off when room temperature reaches the unoccupied set point (adj.).
- On a call for cooling (room temp set point + differential) supply fan cycles ON, and the cooling decreases the room temperature. Unit cycles off when room temperature reaches the unoccupied set point (adj.).
- On a call for dehumidification (room relative humidity set point + differential) dehumidification is enabled.

**MORNING WARMUP/COOL DOWN:** Prior to occupancy, the unit will run using the warmup or cool down sequence until the occupied set point is achieved. The heating or cooling mode must not be locked out and the space temperature is below or above set point by the unoccupied hysteresis (adj.) (This Sequence must be field configured.)

**SUPPLY BLOWER SEQUENCE:** The supply blower is provided with a factory mounted variable frequency drive. The supply blower speed will be controlled with the following sequence.

**Single Zone VAV:** The controller will use a space mounted temperature sensor modulate the supply blower speed to maintain the room-air temperature set point.

**OUTDOOR AIR AND RE-CIRCULATED (RECIRC) AIR DAMPER CONTROL:** The outdoor and recirculated air dampers are factory mounted and wired. Outside air damper and recirculation damper will be inverse positions of each other. Example, when the outside air damper is set to 35% opening, the recirculation damper will be at 65% opening. The modulating actuator will be controlled to dictate position by the following sequence.

C:\Users\Kraft\_P.HP840WIN10X64\Greenheck Fan Corporation\Accurex Sharepoint - SYNC - WI IA\Culvers\Culvers Jobs 2022\Culvers - Plano, IL  
\Culvers - Plano, IL-DOAS R1.acxj

**Constant Position-Adj. Setpoint:** The outside air damper and recirculation damper will be modulating dampers that will be hold a constant position set by the minimum damper setpoint (adj.).

**Supply Fan Reset:** The active source will be set to local from the factory (Minimum outdoor air percentage will be constant, set using the controller) and can be field configured to Supply Fan Reset (The minimum and maximum positions are reset based off supply fan speed).

**COOLING SEQUENCE:** The cooling is controlled to maintain the supply temperature set point. The mechanical cooling will be locked out when the outside air is < 55 F (adj.).

**Packaged DX Cooling (Inverter Scroll):** The controller will provide a modulating signal for cooling. From 0-100%, the inverter scroll will be controlled to maintain discharge temperature. The electronic expansion valve will modulate to maintain 8.0 F of superheat. The controller will provide a modulating signal for cooling. From 0-50%, the inverter scroll will be controlled to maintain discharge temperature. From 50-100% the second stage will be on in combination with the inverter scroll compressor to maintain the discharge temperature. The electronic expansion valve will modulate to maintain 8.0 F of superheat.

**Modulating Hot Gas Reheat Sequence:** During dehumidification the modulating HGRH is controlled to maintain the supply temperature set point.

**Modulating Head Pressure Control:** All condenser fans will have EC motors and will modulate in sync to maintain a head pressure set point.

**DEHUMIDIFICATION CONTROL SEQUENCE:** The cooling is controlled to maintain the cooling-coil set point. The dehumidification sequence will be locked out when the OA is < 10 F(adj.) above the cold-coil set point (adj.).

**Space Set Point Control (Room RH):** The controller will adjust the cold coil leaving air temperature set point between the minimum (adj.) and the maximum (adj.) limits, to satisfy the desired room relative humidity set point. Adjustable locally or by BMS.

**REHEAT SEQUENCE:** While the unit is in dehumidification mode the outdoor air will be reheated via Modulating Hot Gas Reheat for space neutral applications.

**Modulating Hot Gas Reheat:** The controller will modulate the hot gas reheat valve with a 0-10 V signal to maintain the supply temperature set point (adj.).

**HEATING SEQUENCE:** The heating is controlled to maintain the supply temperature set point. The heating will be locked out when the outside air is > 80 F (adj.). Maximum allowable discharge air set point is 100 F.

**Indirect Gas Furnace:** The controller will modulate the indirect gas furnace to maintain the supply temperature set point (adj.).

**TEMPERATURE CONTROL SEQUENCE:** The unit will maintain the supply air discharge setpoint per the following. Adjustable locally or by BMS.

**Space Setpoint Control:** The supply setpoint will adjust between minimum (adj.) and maximum (adj.) limits, to satisfy the desired space temperature setpoint. Adjustable locally or by BMS.

**BUILDING FREEZE PROTECTION:** If the supply air temperature drops below 35 F (adj.) for 300s (adj.), the controller will de-energize the unit and activate the alarm output.

**ECONOMIZER SEQUENCE:** When the application requires cooling, and the outdoor air conditions are suitable for free cooling, the controller will modulate the outdoor air and recirculated air dampers to maintain the discharge temperature set point. If the outdoor air damper modulates to the maximum economizer set point and the discharge temperature is not met, the controller will increase the call for cooling to meet the discharge temperature and could engage mechanical cooling.

**Temp./Enthalpy:** The economizer will be locked out when: the outdoor air is < 40 F DB (adj.) or > 75 F DB (adj.) or > 55 F dew point (adj.); the unit is operating in dehumidification mode; or there is a call for heating

**ALARMS INDICATION:** The controller will display alarms and have one digital output for remote indication of an alarm condition. Possible alarms include:

**Dirty Filter Alarm:** A digital signal is sent to the controller indicating an increased pressure drop across the supply air filter (Must be adjusted in field during start up). The controller will then provide a dirty filter alarm.

**Supply Air Alarm:** The controller monitors the proving switch on supply blower and sends an alarm in the case of the blower proving switch not engaging for 30s (adj.).

**DX Alarm:** The controller monitors the refrigerant pressure. In the case of low refrigerant pressure the compressors will shut down until refrigerant pressure returns to normal values and the controller will send an alarm. In the case of high refrigerant pressure the compressors will shut down, requiring a manual reset and the controller will send a alarm.

**Temperature Sensor Alarm:** The controller sends an alarm in the case of a failed air temperature sensor.

**Humidity Sensor Alarm:** The controller sends an alarm in the case of a failed humidity sensor.

**ACCESSORIES:** The following accessories will be included with the unit to expand the functionality or usability of the controller.

**DDC Remote Interface:** Factory provided, field mounted interface panel that will be wired to the main controller for monitoring and remote adjustments of set points.

**Phase and Brownout Protection:** Factory mounted and wired component which monitors the main power coming into the unit. If a phase drops out, or if the incoming voltage exceeds the acceptable range, the component will turn off the unit to help protect the electrical systems.

**Economizer Fault Detection Diagnostic:** Provides the status and faults of the air economizer to indicate proper economizer sequence operation. This assures the benefits of free cooling when outdoor conditions are suitable for economizer functions. The FDD system will indicate when free cooling is available and if the outside air damper and recirculation damper are reacting properly. If the dampers are not functioning correctly an alarm will be generated.

**Condensate Overflow Unit Shutdown:** Factory mounted condensate overflow switch wired to the unit controller. The controller monitors the condensate overflow switch. If the water level in the drain pan reaches a certain level, the unit will shutdown and send an alarm.

**120V/24V Photoelectric Smoke Detector:** Duct smoke detector is shipped loose for field mounting and wiring in the exhaust air duct. Duct smoke detector contains 2 normally open and 2 normally closed contacts for alarm notification. (To disable unit based off smoke detection smoke detector contacts must be field wired between R and G )"

## Warranty Statement for Dedicated Outdoor Air Systems (DOAS)

### Unit Warranty

Accurex warrants the equipment to be free from defects in material and workmanship for a period of 18 months from ship date. Initial startup must be completed within six months of the shipment date, and a startup report must be submitted to Accurex.

### Heat Exchanger Extended Warranty

Accurex warrants the stainless steel heat exchanger to be free from defects in material and workmanship for a period of 25 years from the shipment date.

### Warranty Notes

Any component which proves defective during the warranty period will be repaired or replaced at Accurex's sole option when returned to our factory, transportation prepaid. All warranties do not include labor costs associated with troubleshooting, removal, or installation. Accurex will not be liable for any consequential, punitive, or incidental damages resulting from use, repair, or operation of any Accurex product. These warranties are exclusive and are in lieu of all other warranties, whether written, oral, or implied, including the warranty of merchantability and the warranty of fitness for a particular purpose. No person (including any agent or salesperson) has authority to expand Seller's obligation beyond the terms of this warranty, or to state that the performance of the product is other than that published by Seller.

*As a result of our commitment to continuous improvement, Accurex reserves the right to change specifications without notice.*

## GKD Roof Curb

Model: GKD-45.9/91.9-G14

Curb Height (in.)	Curb Length (in.)	Curb Width (in.)	Material	Finish Type	Duct Adapter	Curb Weight (lb)
14	91.9	45.9	Galvanized	Galvanized	Yes	159

Standard Construction Features:
All dimensions shown are actual and in units of in.'s
If unit is selected with side or end discharge/return, there will not be bottom connections supplied with the curb.
14 gauge galvanized steel (perimeter channels).
14 gauge galvanized steel (interior channels).
Ships knocked down for field assembly.
Curb insulation to be provided by others.

Curb Detail

### Top View of Curb

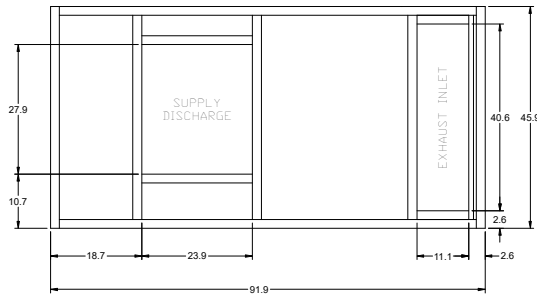

### Cross-Section View of Unit on Curb

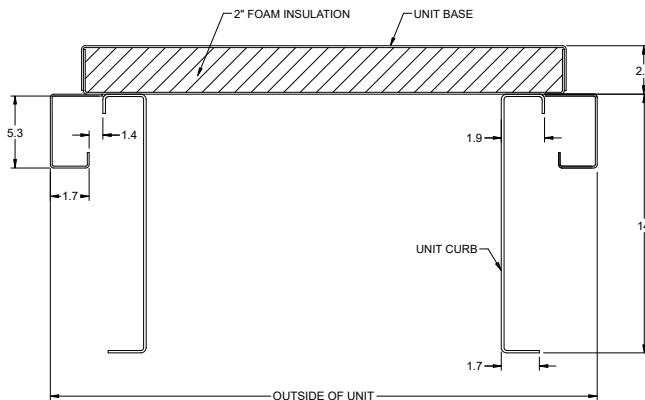

# XRV-25-15J-J-G1

## Unit Performance

Design Conditions							
Elevation (ft)	Summer		Winter DB (F)	Supply (CFM)	Outdoor Air (CFM)	Recirc Air (CFM)	Exhaust Air (CFM)
	DB (F)	WB (F)					
866	89.0	75.0	-25.0	6,150	1,700	4,450	-

Unit Specifications						
Qty	Weight (lb)	Cooling Type	Heating Type	Unit Installation	Unit ETL Listing	Furnace ETL Listing
1	2,459 (+/- 5%)	Packaged DX	Indirect Gas	Outdoor	UL/cUL 1995	ANSI Z83.8 / CSA 2.6

Configuration				
Outdoor Air			Exhaust Air	
Intake	Discharge		Intake	Discharge
End	Bottom		Bottom	End

ASHRAE 90.1-2019 Compliance			
	ASHRAE 90.1 Min. Efficiency	Calculated Efficiency	Compliance
EER	10.8	10.8	✓
IEER	12.2	18.8	✓

Cooling Specifications							
Type	Total Capacity (MBH)	Sensible Capacity (MBH)	Lead Compressor Type	Coil (DB/WB)		Reheat	
				EAT (F)	LAT (F)	Capacity (MBH)	LAT (F)
Packaged DX	207.9	152.1	Inverter Scroll	78.9 / 66.6	56.3 / 56.1	151.7	79.2

Heating Specifications								
Type	Gas Type	Input (MBH)	Output (MBH)	Temperature Rise		Turndown	Performance	
				Min (F)	Max (F)		EAT (F)	LAT (F)
Indirect Gas	Natural	300.0	240.0	9.0	36.0	4:1	45.2	81.3

Air Performance							
Type	Total Volume (CFM)	External SP (in. wg)	Total SP (in. wg)	FRPM	Fan		
					Qty	Type	Drive-Type
Supply	6,150	0.75	3.949	2747	1	Plenum	Direct

Motor Specifications						
Motor	Qty	Operating Power (hp)	Size (hp)	Enclosure	Efficiency	RPM
Supply	1	7.1	10	ODP	PE	1770

Electrical Specifications				
Power Supply	Rating (V/C/P)	MCA (A)	MOP (A)	Fan Power (W/CFM)*
Unit	208/60/3	102.8	150.0	0.860

\*Fan Power (W/CFM) = (Supply BHP + Exhaust BHP) / Supply CFM

### Construction Features And Accessories

Unit	
Unit Installation - Outdoor	Std
Unit Construction - Double Wall	Std
Insulation - 2 inch 2.4# R13 foam	Std
Corrosion Resistant Fasteners	Std
Hinged Access	Std
Factory Wired Non-Fused Disconnect Switch	X
Direct Drive Plenum Blower & Motor Assemblies	X
Factory Wired VFDs	Std
Unit Finish - Permatector, Concrete Gray (RAL 7023)	X
Stainless Steel Condensate Drain Pan and Connection	Std
Condensate Drain Trap	Std
Short Circuit Current - 5 kA	Std
Controls	
Unit Controls - Full Control	Std
Internally Mounted Control Center with 24 VAC control transformer(s) and control circuiting fusing	Std
BMS Protocol - None	
BMS Monitoring Points	
Supply Fan Control - Single Zone VAV	X
Exhaust Fan Control	
Exhaust Fan Only Power	
Energy Wheel Rotation Sensor	
Web-Based User Interface	Std
Outd/Rec. Air Damper Ctrl - Constant Position-Adj. Setpoint	X
Economizer Control Temp./Enthalpy	X
Furnace Control - 4:1 Modulating	X
Control Accessories	
Remote Display - w/150 ft cord	X
Dirty Filter Sensor(s) - Supply	X
Airflow Monitor	
Room Thermostat - Temp and RH	X
Phase/Brownout Protection	Std
Economizer Fault Detection Diagnostics	X

Accessories	
Recirc Air Damper - Low Leakage	X
Outdoor Air Damper - Low Leakage	X
Return Air Damper	
Roof Curb - GKD - 45.9/91.9-G14	X
Supply Air Filters - 2" Merv 13, 2-20x22x2, 2-20x24x2	X
Service Outlet - Factory mounted and wired	X
Piping Vestibule	
Service Lights	
Condensate Overflow Switch	X
Spare Filters	
Exhaust Discharge Gravity Backdraft Damper	
ElectroFin Coil Coating	
Motor Shaft Grounding	
UV Lights	
Bipolar Ionization	
Smoke Detector(s), Exhaust - Shipped Loose	X
Barometric Relief Damper	X
Energy Core Bypass Damper	
Power Venting	Std
Hail Guards	X
Warranty Options	
Unit Warranty - 18 Months (Std.)	Std
Compressor Warranty - 18 Months (Std.)	Std
Furnace HX Warranty - 25 Yrs.	Std

<b>Standard Option</b>	Std
<b>Not Included</b>	
<b>Included</b>	X

Notes
Outdoor Air Damper supplied is low leakage, motorized VCD-23 (leakage rate of 3 CFM / ft <sup>2</sup> @ 1 in. wg), Class 1A

## Special Design Requests

Special Design Number
Special Design Request for "OA - Building Pressure Control", (E1234567)

## Supply Fan Charts And Performance

Supply Fan Performance									
Total Volume (CFM)	External SP (in. wg)	Total SP (in. wg)	RPM	Operating Power (hp)	Motor		Fan		
					Qty	Size (hp)	Qty	Type	Drive-Type
6,150	0.75	3.949	2747	7.1	1	10	1	Plenum	Direct

Pressure Drop (in. wg)						
Weatherhood	Filter	Damper	Cooling	Heating	External	Total
0.02	0.864	0.14	0.745	0.828	0.75	3.949

Sound Performance in Accordance with AMCA										
Sound Power by Octave Band								Lwa	dBA	Sones
62.5	125	250	500	1000	2000	4000	8000			
86	85	97	86	82	76	79	70	91	79	31

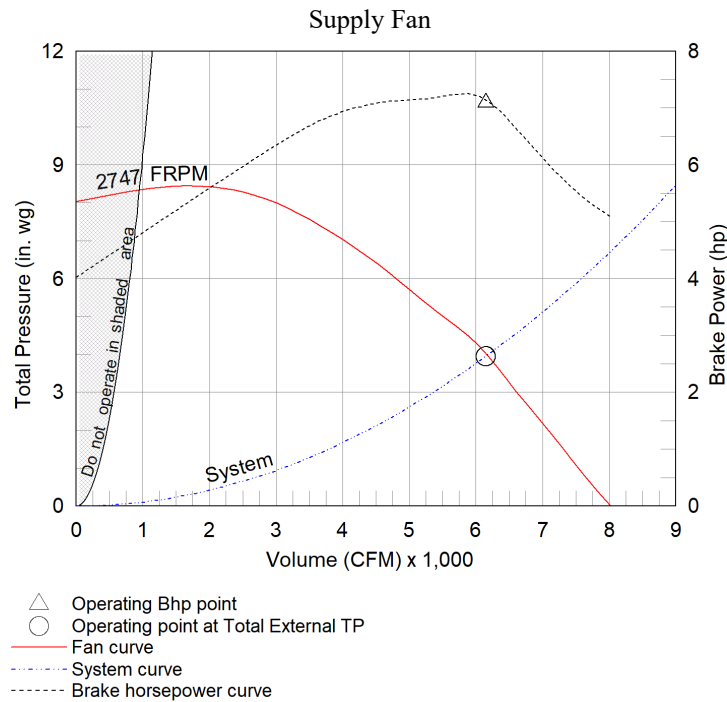

## Radiated Sound

### Position A

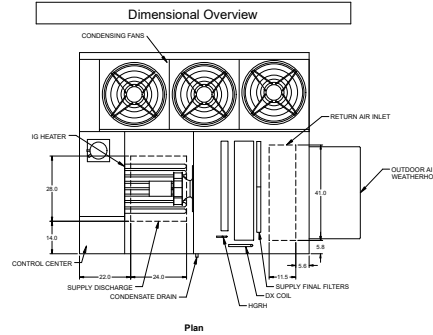

Position D

Position B

Position C

"E" is the  
Top Plane

Supply Air Flow Nominal, Largest Tonnage Condensing Section Available, PDX units only

Radiated Sound Levels										
Plane	Octave Bands (Lw)								Plane Lw	Plane LwA
	1	2	3	4	5	6	7	8		
A	73	85	78	80	81	73	67	62	88	83
B	71	79	69	78	73	68	64	57	83	78
C	79	77	69	76	75	70	60	59	83	78
D	74	77	72	74	74	67	61	58	82	77
E	77	84	78	79	77	72	65	61	87	81
<b>Total</b>	83	89	82	85	84	78	71	67	93	87

AMCA 320-07 - Laboratory Methods of Sound Testing of Fans Using Sound Intensity
Tests conducted in accordance with this standard.
Free field measurement plane created 1 foot from unit on all sides and top.
Sound Intensity measured in Watts/m <sup>2</sup> .
Sound data converted to Sound Power (Lw) for the chart above.
A-Weighted Sound Power was determined using AMCA Standard 301-90 Clause 9.1.
Plane E sound data was measured above the top plane of the unit.

### Cooling Performance

Cooling Specifications									
Nominal Tonnage	Entering Air (F)		Leaving Air (F)		Capacity (MBH)		Reheat		Condensing Ambient Temp (F)
	DB	WB	DB	WB	Total	Sensible	Capacity (MBH)	LAT (F)	
15.0	78.9	66.6	56.3	56.1	207.9	152.1	151.7	79.2	89.0

Coil Information									
PDX Coil Model	Fins Per Inch	Rows Deep	Face Vel. (ft/min)	Coil PD (in. wg)	Refrigerant	Refrig. Velocity (ft/min)	Face Area (ft2)	Suction Temp (F)	
DR516L06S14-45X42.5-LH	14	6	463	0.745	R-410A	1,484	13.3	48.9	

Compressor Details					
Lead Compressor Type	Compressor Qty	Compressor RLA/MRC (A)		Compressor LRA (A)	
		Comp. #1	Comp. #2	Comp. #1	Comp. #2
Inverter Scroll	1	51.3	-	NA	-

Unit Details
Refrigerant charges provided by the factory are approximate and may require adjustment in the field
Hermetic scroll type compressors
Compressors mounted on neoprene vibration isolation
Stainless steel double sloped drain pan
Moisture-indicating sight glass
Service/charging valves
Refrigerant high pressure switch (manual reset)
Liquid-Line filter drier
All condenser fans will have EC motors and will modulate in sync to maintain a head pressure set point.
Inverter scroll compressor
Electronic expansion valve

### Heating Performance

Heating Specifications								
Type	Gas Type	Input (MBH)	Output (MBH)	Temperature Rise		Turndown	Performance	
				Min (F)	Max (F)		EAT (F)	LAT (F)
Indirect Gas	Natural	300.0	240.0	9.0	36.0	4:1	45.2	81.3

Unit Details
ANSI standard Z83.8 and CSA 2.6
High Thermal efficiency
Direct spark ignition
3/4" Gas Connection
At least 6 in. wg of natural gas pressure (14 in. wg for LP) is required at the units gas connection in order to achieve maximum performance
Power Venting
24 Volt Control Power
Stainless Steel heat exchange tubes
Unit controller maximum allowable supply discharge air set point is 100F (37.8C)

## Isometric Drawings

Component Layout

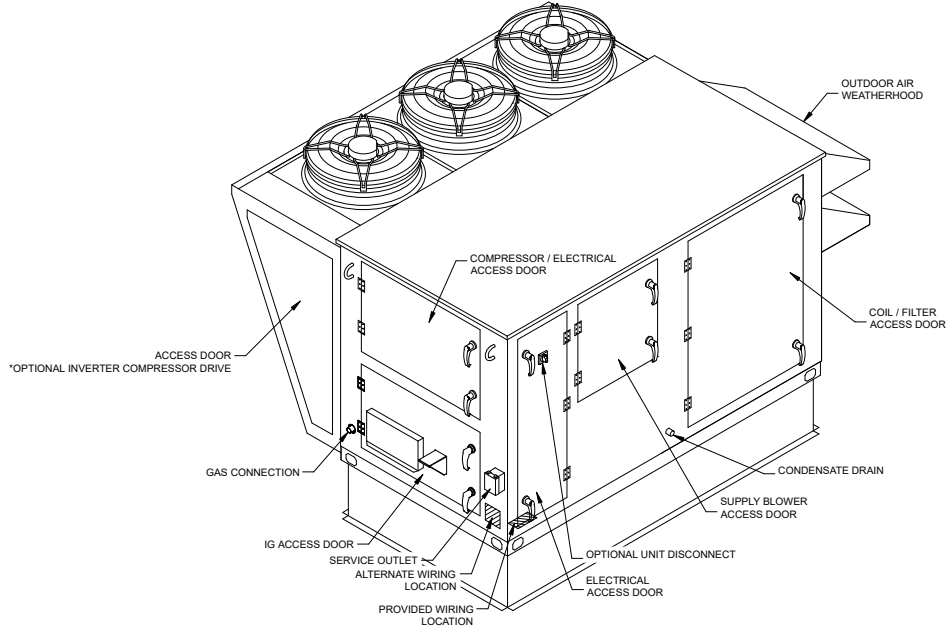

Back Right Isometric

Service Clearances

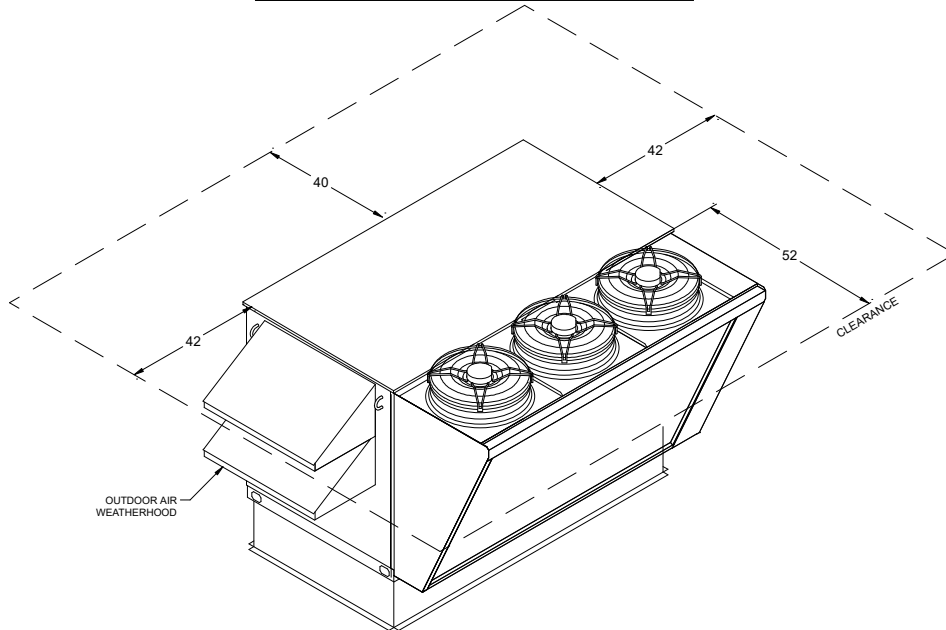

Front Left Isometric

## Overview Drawings

### Dimensional Overview

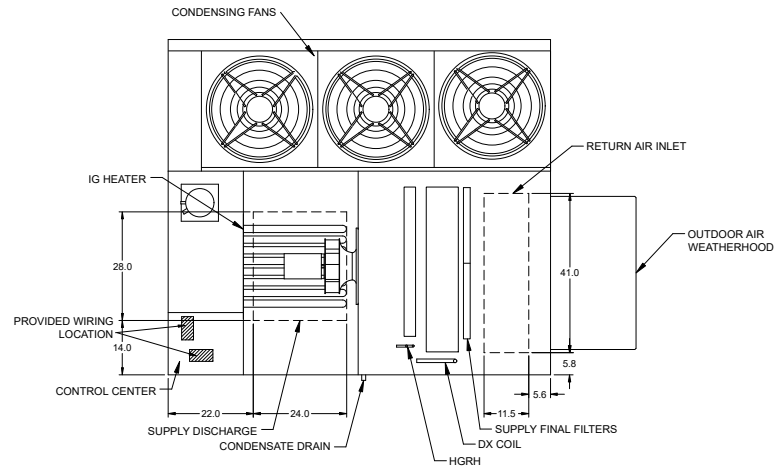
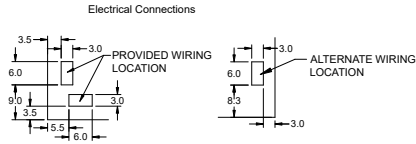

Plan

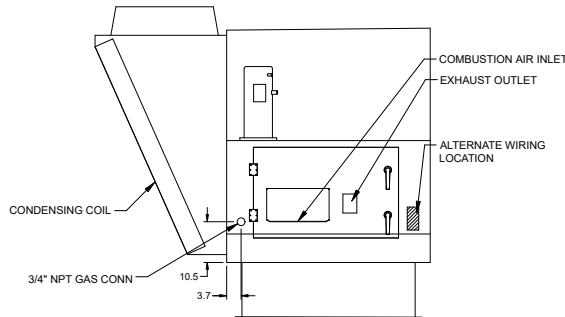

Left End

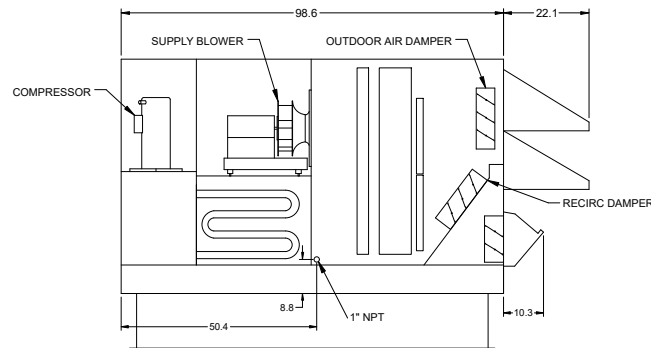

Elevation

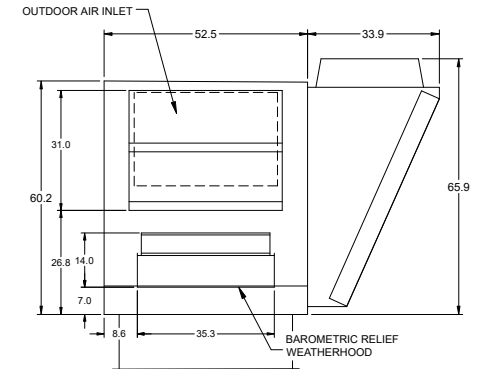

Right End

## Unit Corner Weights

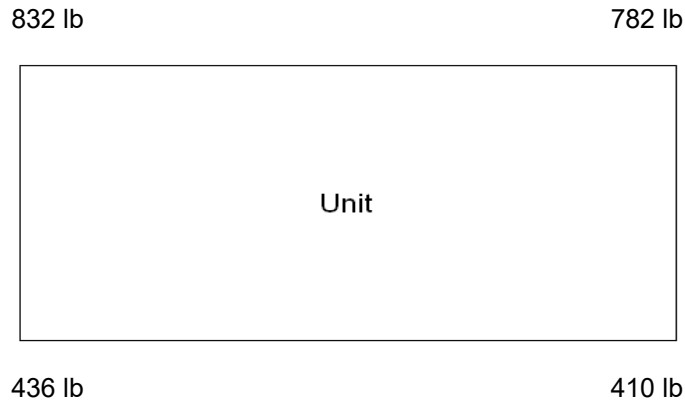

### Note

Estimated corner weights are shown looking down on unit and the outside air intake will be on the right. Weights are applied at the base of the unit. Images not drawn to scale.

## Wiring Diagram

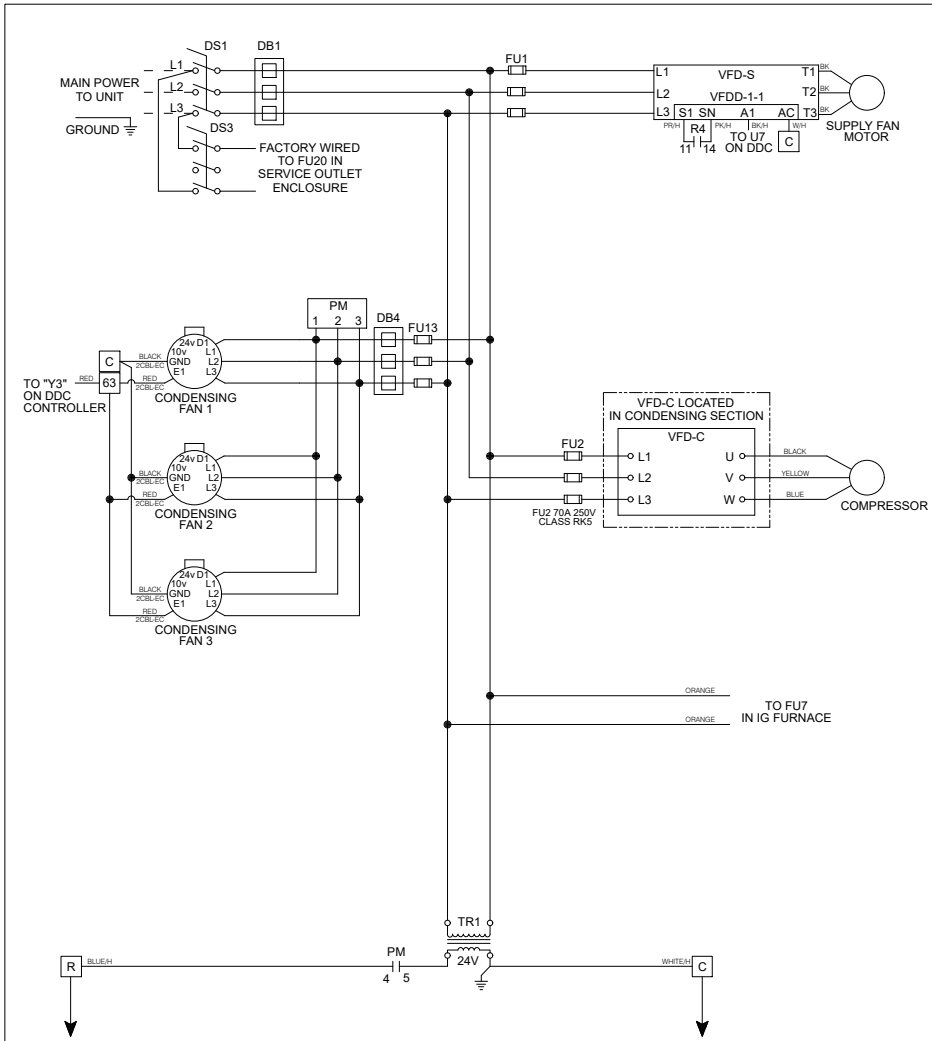

Wiring Diagram Code:  
**A12E2F0XP40C05X00HN33G0600XH27**

**CAUTION**  
 UNIT SHALL BE GROUNDED IN ACCORDANCE WITH N.E.C.  
 POWER MUST BE OFF WHILE SERVICING.

**NOTES**  
 USE COPPER CONDUCTORS ONLY  
 60° C FOR TERMINALS RATED LESS THAN 100 AMPS.  
 75° C FOR TERMINALS RATED 100 AMPS OR MORE.  
 FIELD CONTROL WIRING RESISTANCE SHOULD NOT EXCEED 0.75 OHM.  
 FIELD WIRED - - - - -  
 FACTORY SUPPLIED AND WIRED \_\_\_\_\_

WIRE COLOR CODE			
BK	BLACK	BL	BLUE
BR	BROWN	LT BL	LIGHT BLUE
GY	GRAY	PR	PURPLE
PK	PINK	Y	YELLOW
W	WHITE		
		O	ORANGE
		R	RED

**LEGEND**

DB#	POWER DISTRIBUTION BLOCK
DS	DISCONNECT SWITCH
FU#	FUSES
PM	PHASE VOLTAGE MONITOR
R4	SUPPLY BLOWER VFD RELAY
TR#	TRANSFORMER
VFD	VARIABLE FREQUENCY DRIVE

Wiring Template: H27 DOC NUMBER: 2810022 REV: 16

## Wiring Diagram 2

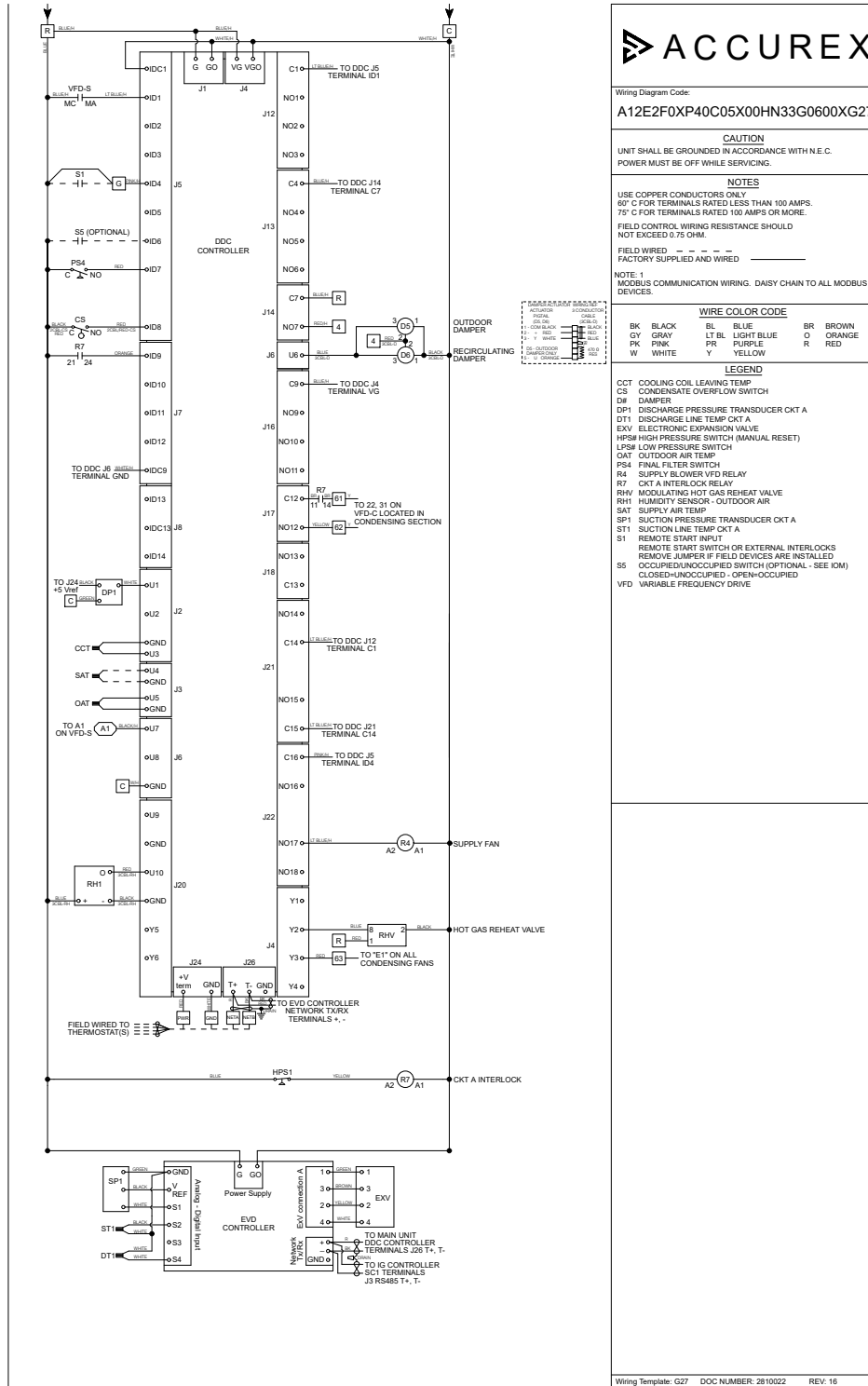

## Wiring Diagram 3

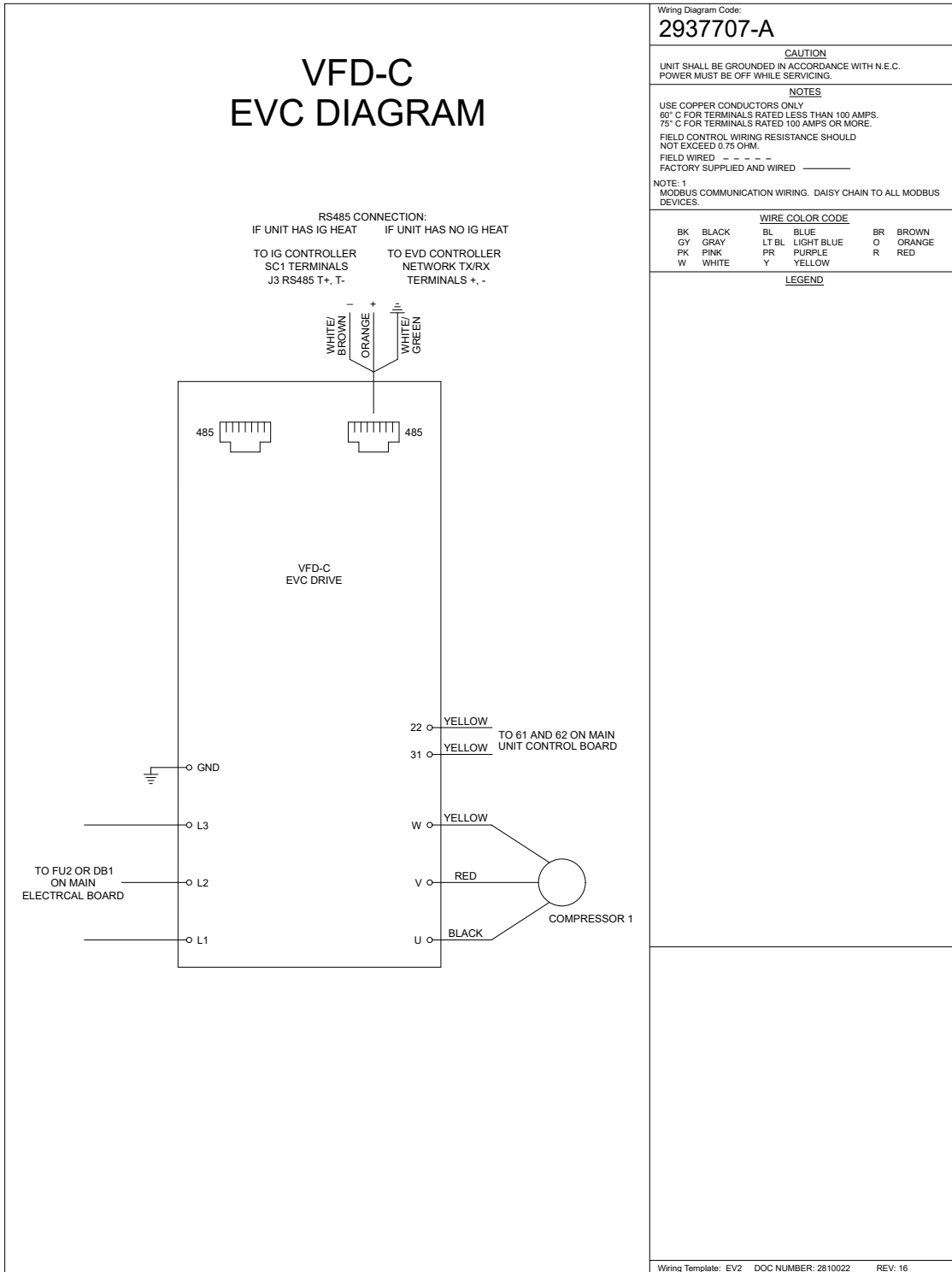

## INDIRECT GAS WIRING DIAGRAM FURNACE 1 - 4:1 MODULATING

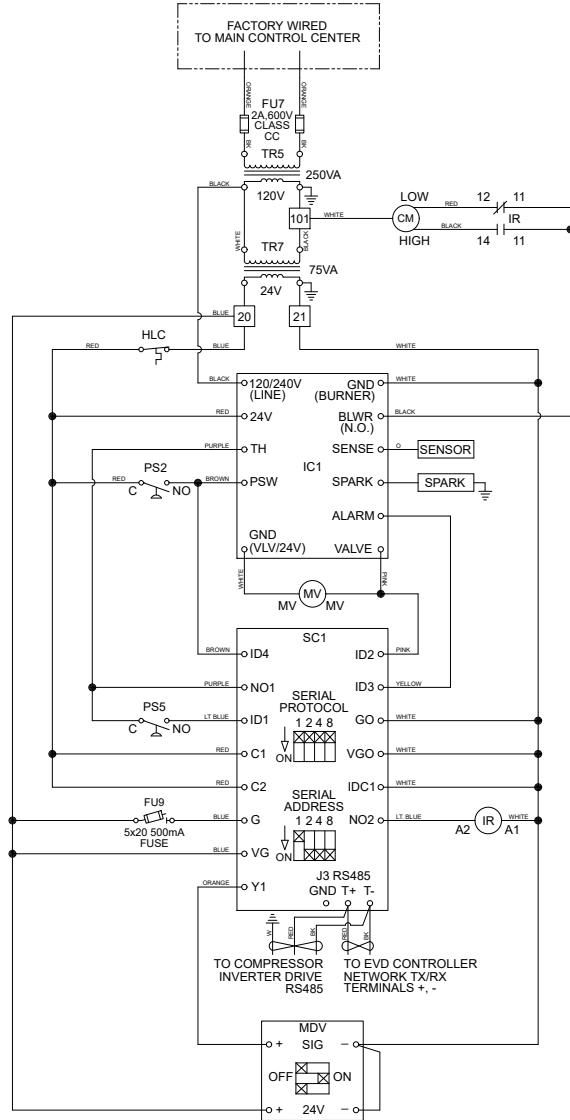

## ACCUREX

Wiring Diagram Code:

**A4K51P1RX0052GS20**

**CAUTION**

UNIT SHALL BE GROUNDED IN ACCORDANCE WITH N.E.C.  
 POWER MUST BE OFF WHILE SERVICING.

**NOTES**

USE COPPER CONDUCTORS ONLY  
 60° C FOR TERMINALS RATED LESS THAN 100 AMPS.  
 75° C FOR TERMINALS RATED 100 AMPS OR MORE.  
 FIELD CONTROL WIRING RESISTANCE SHOULD  
 NOT EXCEED 0.75 OHM.

FIELD WIRED - - - - -  
 FACTORY SUPPLIED AND WIRED \_\_\_\_\_

NOTE: 1  
 MODBUS COMMUNICATION WIRING. DAISY CHAIN TO  
 ALL MODBUS DEVICES.

**WIRE COLOR CODE**

BK	BLACK	BL	BLUE	BR	BROWN
GY	GRAY	LT BL	LIGHT BLUE	O	ORANGE
PK	PINK	PR	PURPLE	R	RED
W	WHITE	Y	YELLOW		

**LEGEND**

CM	COMBUSTION BLOWER MOTOR
FU#	FUSE(S)
HLC	HIGH TEMPERATURE LIMIT CONTROL
IC1	IGNITION CONTROL
IR	INDUCTION RELAY
MDV	MODULATING VALVE
MV	MAIN GAS VALVE
PS2	COMBUSTION AIR PROVING SWITCH
PSS	HIGH SPEED PRESSURE SWITCH
SC1	STAGE CONTROLLER
TR#	TRANSFORMER(S)

## Factory Controller Sequence of Operation

**FACTORY CONTROLLER:** Controller shall be provided with required sensors and programming for rooftop unit. Controller shall be factory programmed, mounted and tested. Controller shall have a LCD readout for changing set points and monitoring unit operation.

### UNIT START COMMAND (Unit will be enabled to start once a jumper is placed between R to G):

- Factory mounted and wired outdoor air and recirculated air damper actuators are powered.
- Supply fan starts after after a (adj.) delay.
- Tempering options to function as described below.

### UNIT STOP COMMAND (OR DE-ENERGIZED):

- Supply fan, exhaust fan and tempering options de-energized.
- Outdoor air damper actuator is spring return close, and the recirculated air damper actuator is spring open.

**OCCUPIED/UNOCCUPIED MODES:** Shall be based on a 7-day time clock internal to the controller. The schedule shall be set by the end user. When a user initiates an override input, the controller will switch from unoccupied to occupied mode. The controller will return to the scheduled occupied/unoccupied mode after the override time has expired. If internal time clock is disabled, a remote contact or a BMS can control the occupied/unoccupied mode.

#### Occupied Mode:

- Damper control per below.
- Supply fan ON.
- Heating per below.
- Cooling per below.

**Unoccupied mode (Cycle on Room Temp):**The unit will cycle to maintain unoccupied room set points if there is a call for unoccupied heating, cooling or dehumidification.

- Supply fan OFF
- Recirculation air damper open.
- Outdoor air damper closed.
- On a call for heating (room temp set point – differential) supply fan cycles ON, and the heating increases the room temperature. Unit cycles off when room temperature reaches the unoccupied set point (adj.).
- On a call for cooling (room temp set point + differential) supply fan cycles ON, and the cooling decreases the room temperature. Unit cycles off when room temperature reaches the unoccupied set point (adj.).
- On a call for dehumidification (room relative humidity set point + differential) dehumidification is enabled.

**MORNING WARMUP/COOL DOWN:** Prior to occupancy, the unit will run using the warmup or cool down sequence until the occupied set point is achieved. The heating or cooling mode must not be locked out and the space temperature is below or above set point by the unoccupied hysteresis (adj.) (This Sequence must be field configured.)

**SUPPLY BLOWER SEQUENCE:** The supply blower is provided with a factory mounted variable frequency drive. The supply blower speed will be controlled with the following sequence.

**Single Zone VAV:** The controller will use a space mounted temperature sensor modulate the supply blower speed to maintain the room-air temperature set point.

**OUTDOOR AIR AND RE-CIRCULATED (RECIRC) AIR DAMPER CONTROL:** The outdoor and recirculated air dampers are factory mounted and wired. Outside air damper and recirculation damper will be inverse positions of each other. Example, when the outside air damper is set to 35% opening, the recirculation damper will be at 65% opening. The modulating actuator will be controlled to dictate position by the following sequence.

C:\Users\Kraft\_P.HP840WIN10X64\Greenheck Fan Corporation\Accurex Sharepoint - SYNC - WI IA\Culvers\Culvers Jobs 2022\Culvers - Plano, IL  
\Culvers - Plano, IL-DOAS R1.acxj

Generated by: phillip.kraft@accurex.com

**Constant Position-Adj. Setpoint:** The outside air damper and recirculation damper will be modulating dampers that will be hold a constant position set by the minimum damper setpoint (adj.).

**Supply Fan Reset:** The active source will be set to local from the factory (Minimum outdoor air percentage will be constant, set using the controller) and can be field configured to Supply Fan Reset (The minimum and maximum positions are reset based off supply fan speed).

**COOLING SEQUENCE:** The cooling is controlled to maintain the supply temperature set point. The mechanical cooling will be locked out when the outside air is < 55 F (adj.).

**Packaged DX Cooling (Inverter Scroll):** The controller will provide a modulating signal for cooling. From 0-100%, the inverter scroll will be controlled to maintain discharge temperature. The electronic expansion valve will modulate to maintain 8.0 F of superheat. The controller will provide a modulating signal for cooling. From 0-50%, the inverter scroll will be controlled to maintain discharge temperature. From 50-100% the second stage will be on in combination with the inverter scroll compressor to maintain the discharge temperature. The electronic expansion valve will modulate to maintain 8.0 F of superheat.

**Modulating Hot Gas Reheat Sequence:** During dehumidification the modulating HGRH is controlled to maintain the supply temperature set point.

**Modulating Head Pressure Control:** All condenser fans will have EC motors and will modulate in sync to maintain a head pressure set point.

**DEHUMIDIFICATION CONTROL SEQUENCE:** The cooling is controlled to maintain the cooling-coil set point. The dehumidification sequence will be locked out when the OA is < 10 F(adj.) above the cold-coil set point (adj.).

**Space Set Point Control (Room RH):** The controller will adjust the cold coil leaving air temperature set point between the minimum (adj.) and the maximum (adj.) limits, to satisfy the desired room relative humidity set point. Adjustable locally or by BMS.

**REHEAT SEQUENCE:** While the unit is in dehumidification mode the outdoor air will be reheated via Modulating Hot Gas Reheat for space neutral applications.

**Modulating Hot Gas Reheat:** The controller will modulate the hot gas reheat valve with a 0-10 V signal to maintain the supply temperature set point (adj.).

**HEATING SEQUENCE:** The heating is controlled to maintain the supply temperature set point. The heating will be locked out when the outside air is > 80 F (adj.). Maximum allowable discharge air set point is 100 F.

**Indirect Gas Furnace:** The controller will modulate the indirect gas furnace to maintain the supply temperature set point (adj.).

**TEMPERATURE CONTROL SEQUENCE:** The unit will maintain the supply air discharge setpoint per the following. Adjustable locally or by BMS.

**Space Setpoint Control:** The supply setpoint will adjust between minimum (adj.) and maximum (adj.) limits, to satisfy the desired space temperature setpoint. Adjustable locally or by BMS.

**BUILDING FREEZE PROTECTION:** If the supply air temperature drops below 35 F (adj.) for 300s (adj.), the controller will de-energize the unit and activate the alarm output.

**ECONOMIZER SEQUENCE:** When the application requires cooling, and the outdoor air conditions are suitable for free cooling, the controller will modulate the outdoor air and recirculated air dampers to maintain the discharge temperature set point. If the outdoor air damper modulates to the maximum economizer set point and the discharge temperature is not met, the controller will increase the call for cooling to meet the discharge temperature and could engage mechanical cooling.

**Temp./Enthalpy:** The economizer will be locked out when: the outdoor air is < 40 F DB (adj.) or > 75 F DB (adj.) or > 55 F dew point (adj.); the unit is operating in dehumidification mode; or there is a call for heating

**ALARMS INDICATION:** The controller will display alarms and have one digital output for remote indication of an alarm condition. Possible alarms include:

**Dirty Filter Alarm:** A digital signal is sent to the controller indicating an increased pressure drop across the supply air filter (Must be adjusted in field during start up). The controller will then provide a dirty filter alarm.

**Supply Air Alarm:** The controller monitors the proving switch on supply blower and sends an alarm in the case of the blower proving switch not engaging for 30s (adj.).

**DX Alarm:** The controller monitors the refrigerant pressure. In the case of low refrigerant pressure the compressors will shut down until refrigerant pressure returns to normal values and the controller will send an alarm. In the case of high refrigerant pressure the compressors will shut down, requiring a manual reset and the controller will send a alarm.

**Temperature Sensor Alarm:** The controller sends an alarm in the case of a failed air temperature sensor.

**Humidity Sensor Alarm:** The controller sends an alarm in the case of a failed humidity sensor.

**ACCESSORIES:** The following accessories will be included with the unit to expand the functionality or usability of the controller.

**DDC Remote Interface:** Factory provided, field mounted interface panel that will be wired to the main controller for monitoring and remote adjustments of set points.

**Phase and Brownout Protection:** Factory mounted and wired component which monitors the main power coming into the unit. If a phase drops out, or if the incoming voltage exceeds the acceptable range, the component will turn off the unit to help protect the electrical systems.

**Economizer Fault Detection Diagnostic:** Provides the status and faults of the air economizer to indicate proper economizer sequence operation. This assures the benefits of free cooling when outdoor conditions are suitable for economizer functions. The FDD system will indicate when free cooling is available and if the outside air damper and recirculation damper are reacting properly. If the dampers are not functioning correctly an alarm will be generated.

**Condensate Overflow Unit Shutdown:** Factory mounted condensate overflow switch wired to the unit controller. The controller monitors the condensate overflow switch. If the water level in the drain pan reaches a certain level, the unit will shutdown and send an alarm.

**120V/24V Photoelectric Smoke Detector:** Duct smoke detector is shipped loose for field mounting and wiring in the exhaust air duct. Duct smoke detector contains 2 normally open and 2 normally closed contacts for alarm notification. (To disable unit based off smoke detection smoke detector contacts must be field wired between R and G )"

## Warranty Statement for Dedicated Outdoor Air Systems (DOAS)

### Unit Warranty

Accurex warrants the equipment to be free from defects in material and workmanship for a period of 18 months from ship date. Initial startup must be completed within six months of the shipment date, and a startup report must be submitted to Accurex.

### Heat Exchanger Extended Warranty

Accurex warrants the stainless steel heat exchanger to be free from defects in material and workmanship for a period of 25 years from the shipment date.

### Warranty Notes

Any component which proves defective during the warranty period will be repaired or replaced at Accurex's sole option when returned to our factory, transportation prepaid. All warranties do not include labor costs associated with troubleshooting, removal, or installation. Accurex will not be liable for any consequential, punitive, or incidental damages resulting from use, repair, or operation of any Accurex product. These warranties are exclusive and are in lieu of all other warranties, whether written, oral, or implied, including the warranty of merchantability and the warranty of fitness for a particular purpose. No person (including any agent or salesperson) has authority to expand Seller's obligation beyond the terms of this warranty, or to state that the performance of the product is other than that published by Seller.

*As a result of our commitment to continuous improvement, Accurex reserves the right to change specifications without notice.*

## GKD Roof Curb

Model: GKD-45.9/91.9-G14

Curb Height (in.)	Curb Length (in.)	Curb Width (in.)	Material	Finish Type	Duct Adapter	Curb Weight (lb)
14	91.9	45.9	Galvanized	Galvanized	Yes	159

Standard Construction Features:
All dimensions shown are actual and in units of in.'s
If unit is selected with side or end discharge/return, there will not be bottom connections supplied with the curb.
14 gauge galvanized steel (perimeter channels).
14 gauge galvanized steel (interior channels).
Ships knocked down for field assembly.
Curb insulation to be provided by others.

Curb Detail

### Top View of Curb

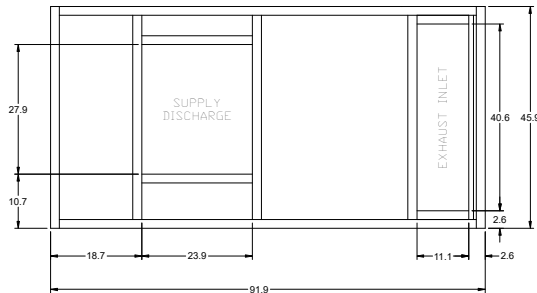

### Cross-Section View of Unit on Curb

