

FOR QUESTIONS, CALL THE
Highwoods Group
REGION 40
PHONE: (919) 875-0420
EMAIL: reg40@captiveaire.com

PATENT NUMBERS
EXHAUST HOODS ND-2/BD-2/SND-2 (CANADA) - CA PATENT 2520435 C.

HOOD INFORMATION - JOB#5274616

HOOD NO	TAG	MODEL	MANUFACTURER	LENGTH	MAX COOKING TEMP	TYPE	APPLIANCE DUTY	DESIGN CFM/FT	TOTAL EXH CFM	EXHAUST PLENUM RISER(S)				HOOD CONSTRUCTION	HOOD CONFIG		SWITCHES				
										WIDTH	LENG	HEIGHT	DIA		CFM	VEL	SP	END TO END	ROW	QUANTITY	LOCATION
1	HD-1	5424 ND-2	CAPTIVEAIRE	14' 3"	600 DEG	I	HEAVY	225	3200	10'	30'	4'	3200	1536	-0.834"	430 SS WHERE EXPOSED	ALONE	ALONE	1 FAN 1 LIGHT	FRONT RIGHT FACE	
2	HD-2	4824 VHB-G-ND	CAPTIVEAIRE	4' 6"	700 DEG	II	N/A	100	450			4'	8'	450	1289	-0.077"	430 SS 100%	ALONE	ALONE		

HOOD INFORMATION

HOOD NO	TAG	FILTER(S)				LIGHT(S)				UTILITY CABINET(S)				FIRE SYSTEM PIPING	HOOD HANGING WEIGHT		
		TYPE	QTY	HEIGHT	LENGTH	EFFICIENCY @ 7 MICRONS	QTY	TYPE	WIRE GUARD	LOCATION	SIZE	FIRE SYSTEM TYPE	SIZE			ELECTRICAL MODEL #	SWITCHES QUANTITY
1	HD-1	CAPTRATE SOLID FILTER	10	20"	16"	85% SEE FILTER SPEC	10	L55 SERIES E26	NO	LEFT	12"x54"x24"	ANSUL R-102	3.0/3.0	SC-311110MA	1 LIGHT 1 FAN	YES	977 LBS
2	HD-2						2	RECESSED ROUND	NO							NO	204 LBS

HOOD OPTIONS

HOOD NO	TAG	OPTION
1	HD-1	FIELD WRAPPER 6.00" HIGH FRONT, LEFT, RIGHT.
		RIGHT END STANDOFF (FINISHED) 1" WIDE 54" LONG INSULATED.
		LEFT QUARTER END PANEL 23" TOP WIDTH, 0" BOTTOM WIDTH, 23" HIGH 430 SS.
		INSULATION FOR TOP OF HOOD.
		INSULATION FOR BACK OF HOOD.
2	HD-2	RISER SENSOR INSTALL 6IN PLEN.
		FULL DIMENSION HANGING BRACKET - FRONT.
		FIELD WRAPPER 6.00" HIGH FRONT, LEFT, RIGHT, BACK.

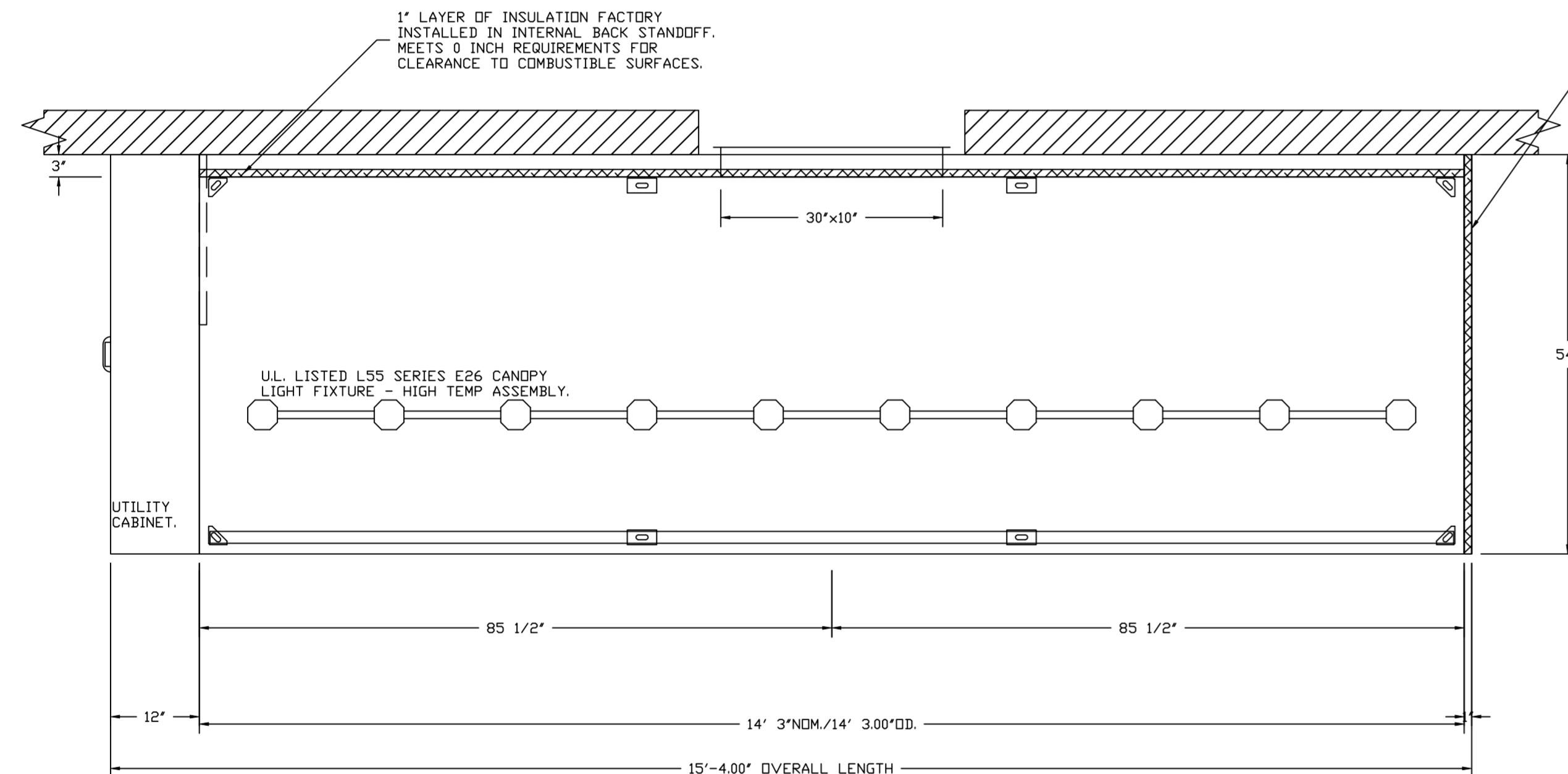

PLAN VIEW - HOOD #1 (HD-1)
14' 3.00" LONG 5424ND-2

NOTE: ADDITIONAL HANGING ANGLES PROVIDED FOR HOODS 12' AND LONGER.

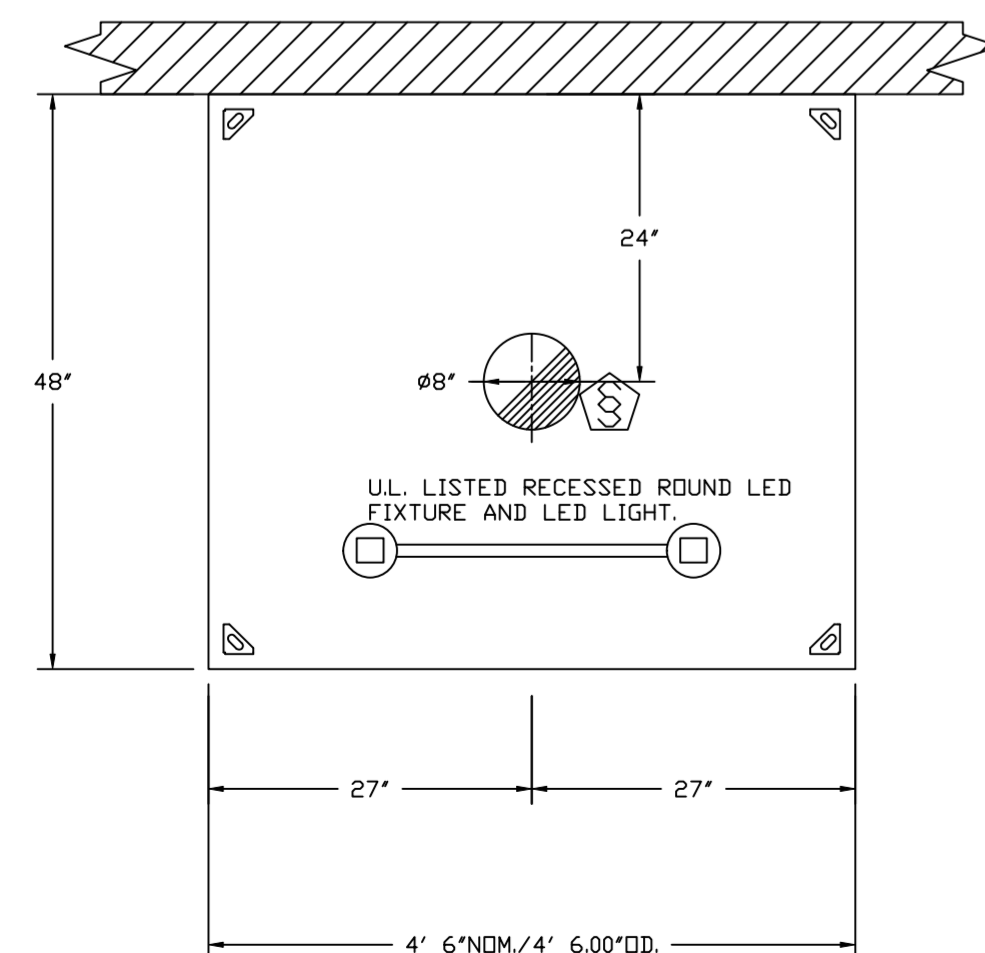

PLAN VIEW - HOOD #2 (HD-2)
4' 6.00" LONG 4824VHB-G-ND

SPECIFICATION: CAPTRATE® GREASE-STOP® SOLID FILTER

THE CAPTRATE GREASE-STOP SOLID FILTER IS A SINGLE-STAGE FILTER FEATURING A UNIQUE S-Baffle DESIGN IN CONJUNCTION WITH A SLOTTED REAR Baffle DESIGN, TO DELIVER EXCEPTIONAL FILTRATION EFFICIENCY.

FILTER IS STAINLESS STEEL CONSTRUCTION, AND SIZED TO FIT INTO STANDARD 2-INCH DEEP HOOD CHANNEL(S).

UNITS SHALL INCLUDE STAINLESS STEEL HANDLES AND A FASTENING DEVICE TO SECURE THE TWO COMPONENTS WHEN ASSEMBLED.

GREASE EXTRACTION EFFICIENCY PERFORMANCE SHALL REMOVE AT LEAST 75% OF GREASE PARTICLES FIVE MICRONS IN SIZE, AND 85% GREASE PARTICLES SEVEN MICRONS IN SIZE AND LARGER, WITH A CORRESPONDING PRESSURE DROP NOT TO EXCEED 1.0 INCHES OF WATER GAUGE.

THE CAPTRATE GREASE-STOP SOLID WAS TESTED TO ASTM STANDARD ASTM F2519-05, MANUFACTURER APPROVED FOR USE IN SOLID FUEL APPLICATIONS AS A SPARK ARRESTER.

EFFICIENCY VS. PARTICLE DIAMETER

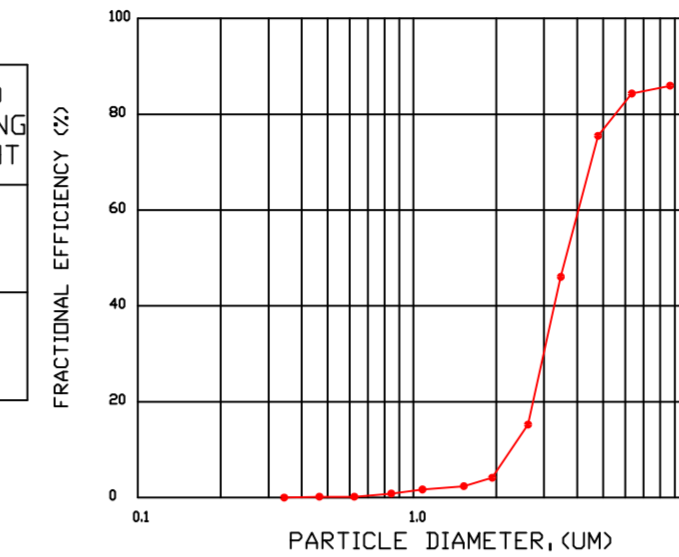

PRESSURE DROP VS. FLOW RATE

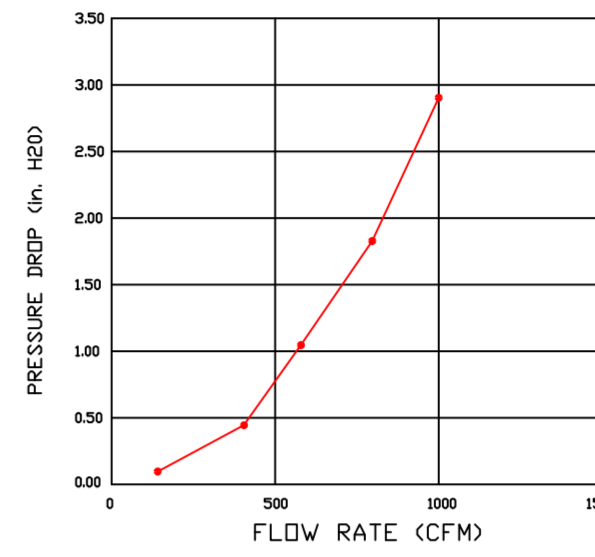

CAPTRATE FILTERS ARE BUILT IN COMPLIANCE WITH:
NFPA #96.
UL STANDARD #2.
UL STANDARD #1046.
INT. MECH. CODE (IMC).
ULC-S649.

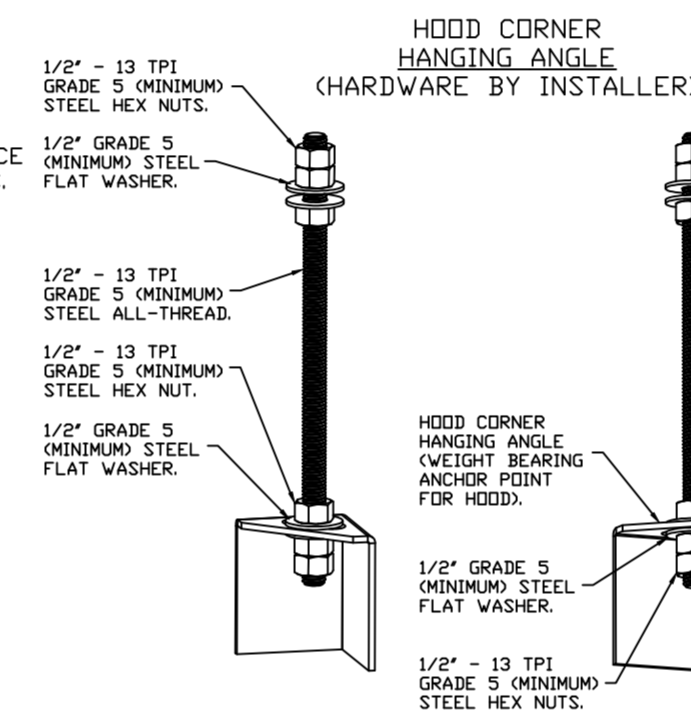

ASSEMBLY INSTRUCTIONS

HANGING ANGLE MUST BE SUPPORTED WITH 1/2" - 13 TPI GRADE 5 (MINIMUM) ALL-THREAD, SANDWICH HANGING ANGLES AND CEILING ANCHOR POINTS WITH 1/2" GRADE 5 (MINIMUM) STEEL FLAT WASHERS AND 1/2" - 13 TPI GRADE 5 (MINIMUM) HEX NUTS AS SHOWN. MUST USE DOUBLED HEX NUT CONFIGURATION BENEATH HOOD HANGING ANGLES AND ABOVE CEILING ANCHORS. MAINTAIN 1/4" OF EXPOSED THREADS BENEATH BOTTOM HEX NUT. TORQUE ALL HEX NUTS TO 57 FT-LBS.

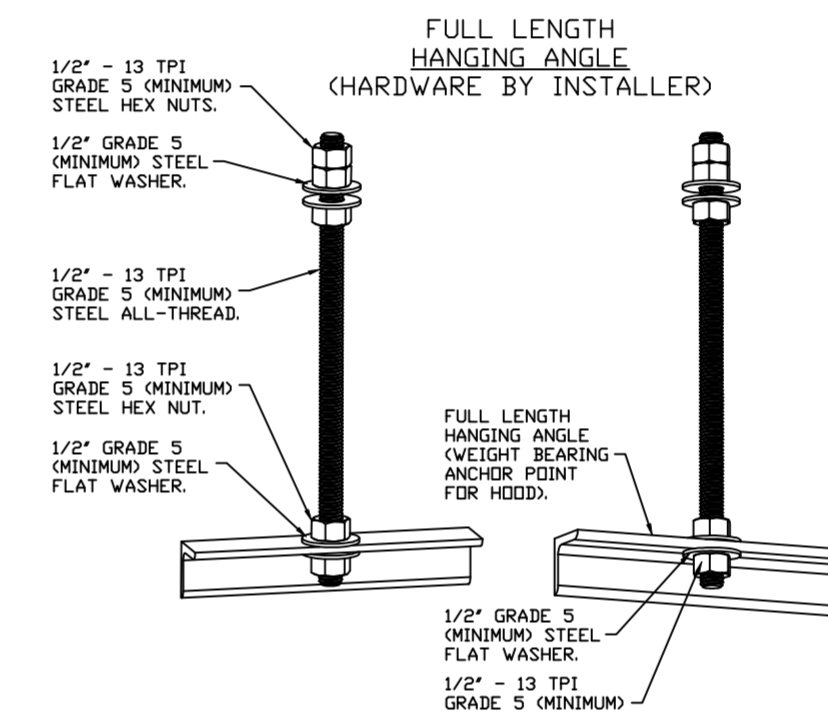

ASSEMBLY INSTRUCTIONS

HANGING ANGLE MUST BE SUPPORTED WITH 1/2" - 13 TPI GRADE 5 (MINIMUM) ALL-THREAD, SANDWICH HANGING ANGLES AND CEILING ANCHOR POINTS WITH 1/2" GRADE 5 (MINIMUM) STEEL FLAT WASHERS AND 1/2" - 13 TPI GRADE 5 (MINIMUM) HEX NUTS AS SHOWN. MUST USE DOUBLED HEX NUT CONFIGURATION ABOVE CEILING ANCHORS. SINGLE HEX NUT BENEATH HANGING ANGLE IS ACCEPTABLE FOR FULL LENGTH HANGING ANGLES. MAINTAIN 1/4" OF EXPOSED THREADS BENEATH BOTTOM HEX NUT. TORQUE ALL HEX NUTS TO 57 FT-LBS.

REVISIONS

DESCRIPTION	DATE

CAPTIVEAIRE

Highwoods Group
www.captiveaire.com

4641 Paragon Park Rd., Raleigh, NC 27616 PHONE: (919) 875-0420 FAX: (919) 875-0577 EMAIL: reg40@captiveaire.com

CHIPOTLE LOYOLA PEARSON #4272
109 E Pearson St,
Chicago, IL, 60611

DATE: 7/1/2022
DWG.#: 5274616
DRAWN BY: JMB-40
SCALE: 3/4" = 1'-0"
MASTER DRAWING

SHEET NO. 1

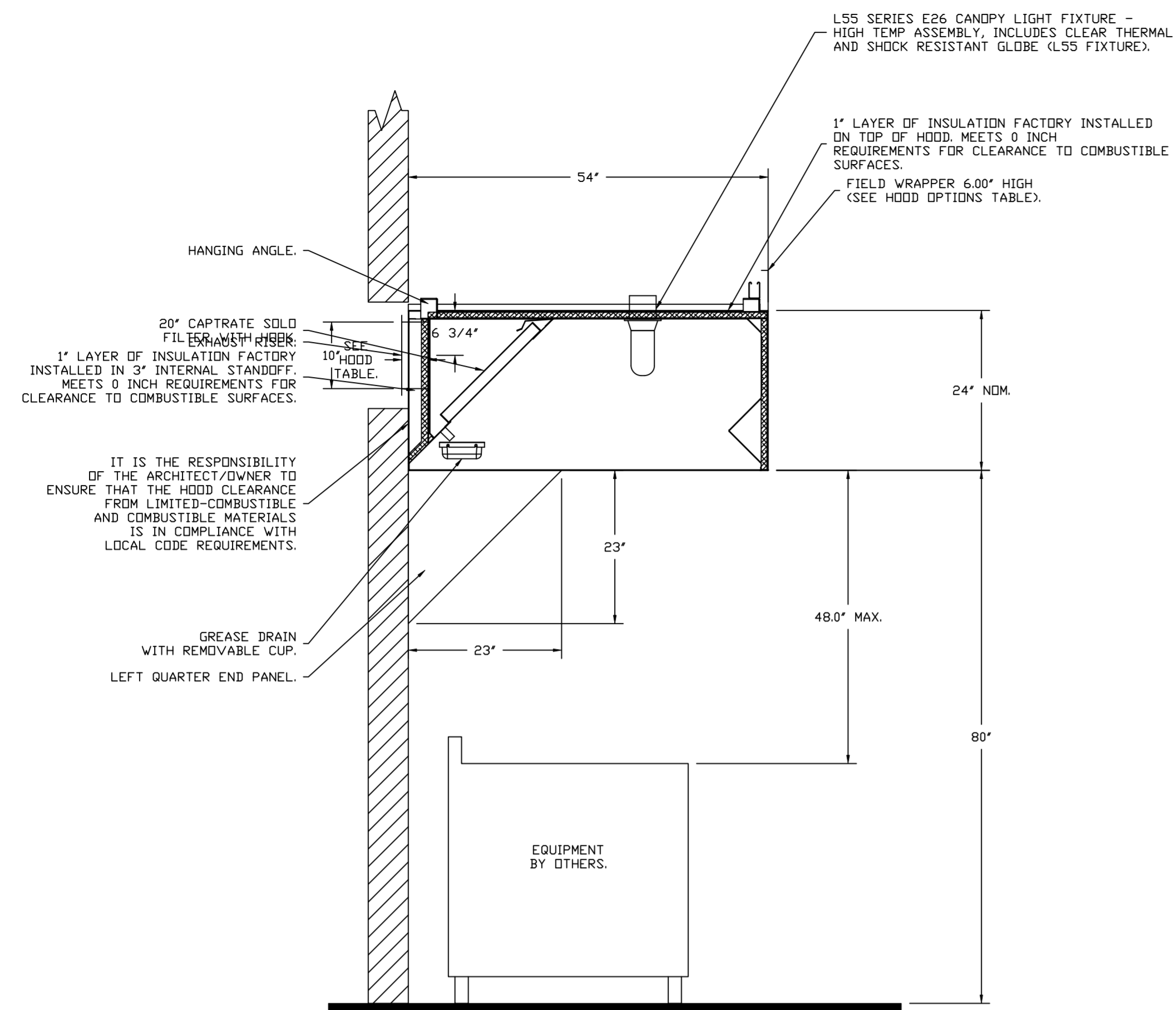

SECTION VIEW - MODEL 5424ND-2
HOOD - #1 - 1 Rear Riser(s) (HD-1)

RISER	A (HEIGHT/DIAMETER)	B (VERTICAL DIMENSION)
1	10	5.500

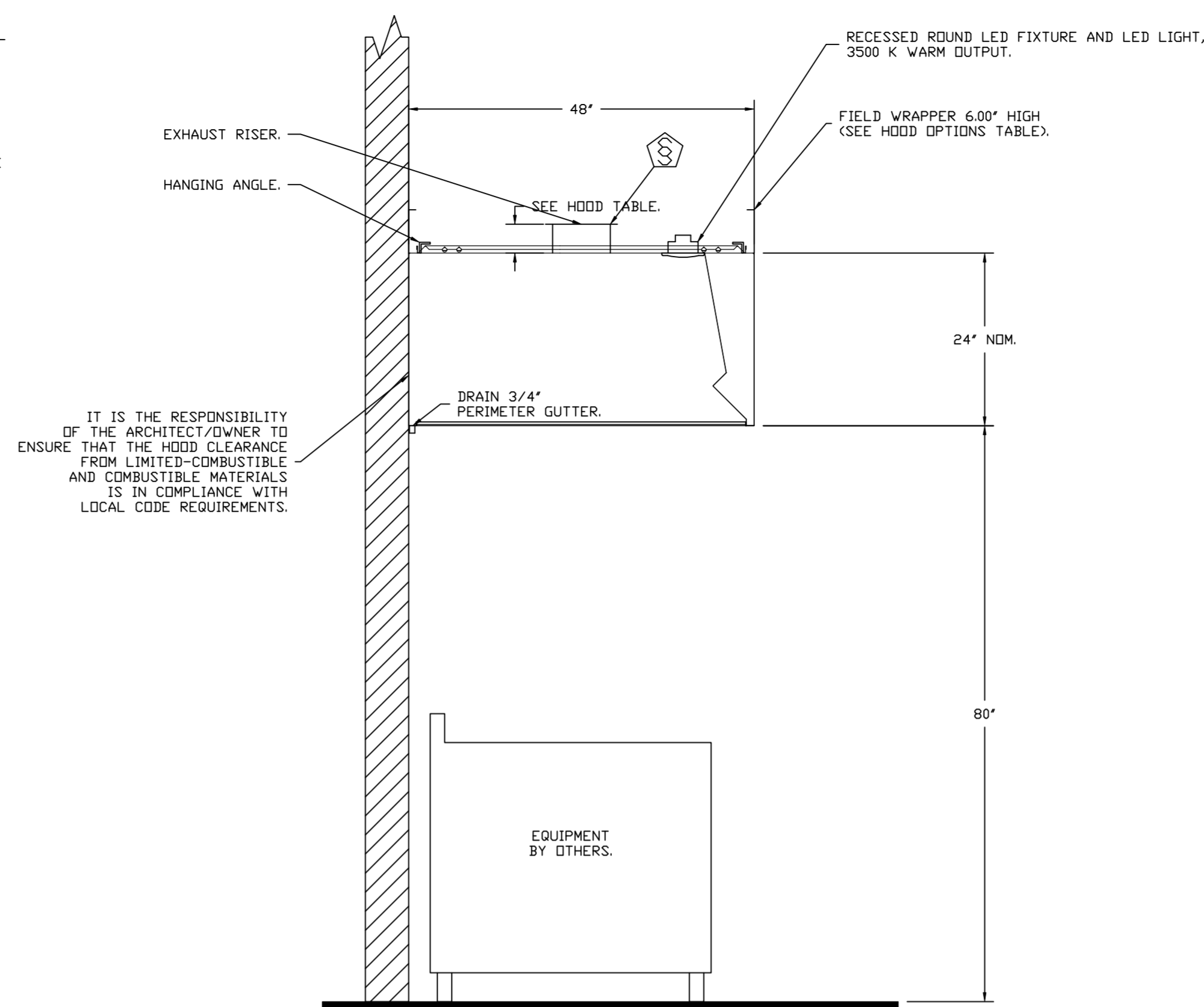

SECTION VIEW - MODEL 4824VHB-G-ND
HOOD - #2 (HD-2)

FIRE SYSTEM INFORMATION - JOB#5274616

FIRE SYSTEM NO	TAG	TYPE	SIZE	FLOW POINTS	INSTALLATION	
					SYSTEM	LOCATION ON HOOD
1		ANSUL R102	3.0/3.0	4	FIRE CABINET LEFT	LEFT, HOOD 1

GAS VALVE(S)

FIRE SYSTEM NO	TAG	TYPE	SIZE	SUPPLIED BY
1		SC ELECTRICAL	2.000	CAPTIVEAIRE SYSTEMS

REVISIONS

DESCRIPTION	DATE

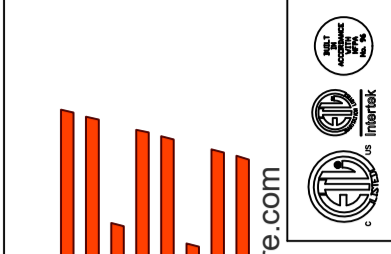

CAPTIVE AIR
Highwoods Group
www.captiveaire.com
4641 Paragon Park Rd., Raleigh, NC, 27616 PHONE: (919) 875-0420 FAX: (919) 875-0577 EMAIL: reg@captlive.com

CHIPOTLE LOYOLA PEARSON #4272
109 E Pearson St,
Chicago, IL, 60611

DATE: 7/1/2022

DWG.#:
5274616

DRAWN BY:
JMB-40

SCALE:
3/4" = 1'-0"

MASTER DRAWING

SHEET NO.
2

SPECIFICATIONS

TAG: Commercial Kitchen Ventilation Hoods, Listed Commercial Kitchen Hoods

PART 1 - GENERAL

1.1 SUMMARY

- A. The ND2 series is a Type I, wall canopy hood for use over 600°F, 700°F cooking surface temperatures. The aerodynamic design includes a mechanical baffle and performance enhancing lip for exceptional capture and containment.
- B. The VHB Series is a Premier Type II, exhaust only hood used over equipment not producing grease laden vapors. Type II hoods are used for condensation or heat removal applications.
- C. The hood shall have the size, shape, and performance specified on drawings.

1.2 SUBMITTALS

- A. The manufacturer assumes no liability for the use or results of use from this document. Specifications are to be reviewed by the engineer to confirm the project's requirements and meet Federal, State, and Local codes and regulations.
- B. As the manufacturer continues product development, it reserves the right to change design and specifications without notice.
- C. The manufacturer shall supply complete computer generated submittal drawings, including hood section view(s) and hood plan view(s). These drawings must be available to the engineer, architect, and owner for their use in construction, operation, and maintenance.

1.3 QUALITY ASSURANCE

- A. This hood is ETL-listed to standard UL710, ULC710, and ULC-S646 when installed in accordance with these installation instructions and National Fire Protection Association Standard NFPA 96, Standard for Ventilation Control and Fire Protection of Commercial Cooking Operations."
- B. Built-in compliance with NSF/ANSI Standard 2.
- C. The hood shall be ETL Listed as:
1. "Exhaust Hood Without Exhaust Damper."
 2. ETL Sanitation Listed and built in accordance with NFPA 96.
 3. The ETL label shall list temperature rating(s) and minimum CFM/ft rating(s).

1.4 WARRANTY

- A. All units shall be provided with the following standard warranty:
1. This equipment is warranted to be free from defects in materials and workmanship, under normal use and service, for a period of 2-years from date of shipment.
- B. The manufacturer shall not be liable for incidental and consequential losses and damages potentially attributable to malfunctioning equipment. Should any part of the equipment prove to be defective in material or workmanship within the 2-year warranty period, upon examination by the manufacturer, such part will be repaired or replaced by manufacturer at no charge. The buyer shall pay all labor costs incurred in connection with such repair or replacement. Equipment shall not be returned without manufacturer's prior authorization, and all returned equipment shall be shipped by the buyer, freight prepaid to a destination determined by the manufacturer.
- C. Refer to Manufacturer's Operation, Installation, and Maintenance (OIM) Manual for detailed descriptions of what is/is not covered and contact information for warranty claims.

PART 2 - PRODUCTS

2.1 GENERAL

- A. Construction shall be dependent on the structural application to minimize distortion and other defects. All seams, joints, and penetrations of the hood enclosure to the lower outermost

perimeter, which directs and captures grease-laden vapor and exhaust gases, shall have a liquid-tight continuous external weld in accordance with NFPA 96.

- B. Duct sizes, CFM, and static pressure requirements shall be as shown on drawings. Static pressure requirements shall be precise and accurate; air velocity and volume information shall be accurate within 1-ft increments along the length of the ventilator.

2.2 CONSTRUCTION

- A. Construction shall be type 430 stainless steel.
- B. Double wall insulated front to eliminate condensation and increase rigidity on wide sizes. The insulation shall have a flexural modulus of 475 EI, meet UL 181 requirements and be in accordance with NFPA 90A and 90B.
- C. Hood shall be equipped with a minimum of four connections for hanger rods. Hood lengths greater than 12' will have added hangers.
- D. Exhaust duct collar to be 4" high with flange.
- E. The grease drain system shall be an enclosed integral part of the hood back and have slopes with an exposed, removable 1/2 grease cup to facilitate cleaning.
- F. An integral baffle to direct grease laden vapors toward the exhaust filter bank.
- G. Hood shall be furnished with UL classified filters, supplied in size and quantity as required by ventilator.
- H. All seams shall be welded and have stainless steel on exposed surfaces.

2.3 LIGHTING

- A. L55 Series canopy light fixture, includes clear thermal and shock resistant globe.
- B. Recessed round LED fixture and LED light, 3500K Warm output.

2.4 FILTERS

- A. Stainless Steel Captrate Solo filter with hook, ETL Listed. Particulate capture efficiency: 85% efficient at 9 microns, 76% efficient at 5 microns.

2.5 OPTIONS

- A. Fire Suppression System: UL 300 fire suppression system.
- B. Hood Mounted Utility Cabinet - Cabinet can store listed fire suppression system, listed components, pre-wired electrical controls.

2.6 ACCESSORIES

- A. End Panel(s) maximize hood performance and eliminate the effects of cross drafts in the kitchen. Units constructed of stainless steel and sized according to hood width and cooking equipment. Exposed edges hemmed for safety and rigidity. Selected panels:
1. Quarter End Panel
- B. Standoff(s) selected:
1. Right End Standoff
- C. Wrapper(s) may be installed from the factory or field installed. Wrapper(s) selected:
1. Wrapper
- D. Miscellaneous option(s) selected:
1. Full Dimension Hanging Bracket -Unistrut added to allow for various hood mounting locations.
 2. Insulation for Top of Hood -Fully insulated top of hood.
 3. Insulation for Back of Hood -Backside of hood is fully insulated.
 4. Riser Sensor Install -Sensor set-up for 6" plenum.

PART 3 - EXECUTION

3.1 EXAMINATION

- A. Examine areas and conditions under which the system is installed. Do

not proceed with work until unsatisfactory conditions have been corrected in a manner acceptable to Installer.

3.2 INSTALLATION

- A. Install in accordance with manufacturer's instructions, drawings, written specifications, manufacturer's installation manual, and all applicable building codes.

REVISIONS

DESCRIPTION	DATE
△	
△	
△	
△	

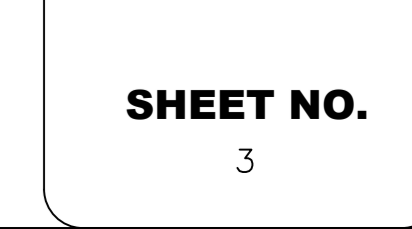
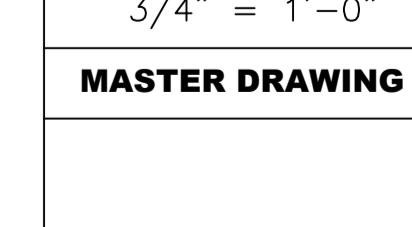
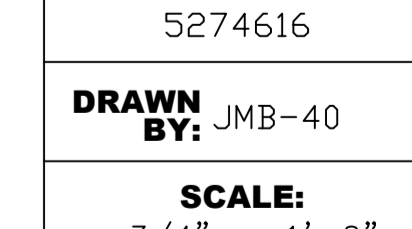
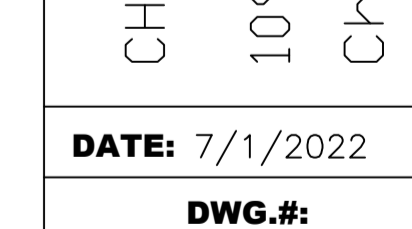
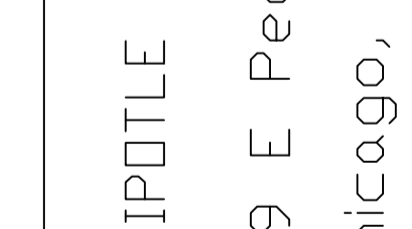
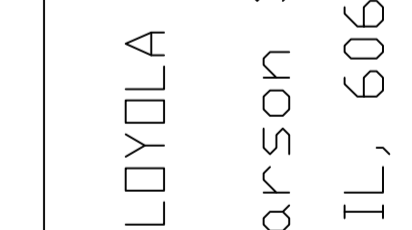
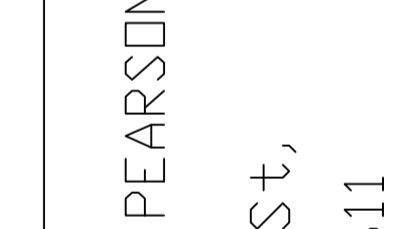
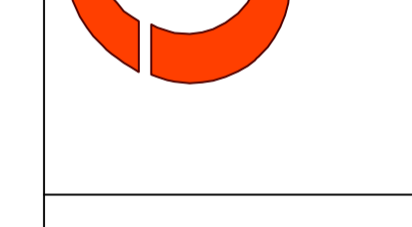
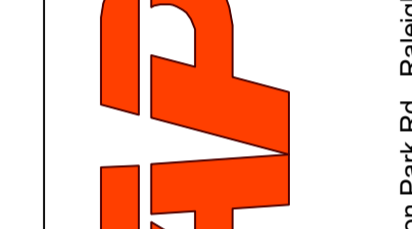
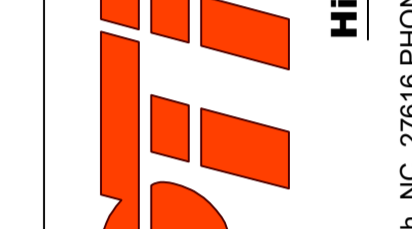
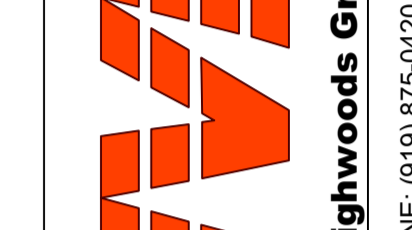
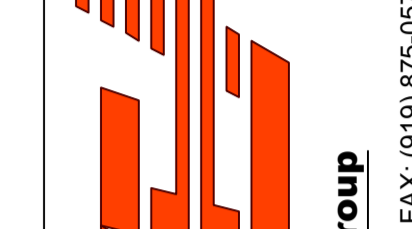
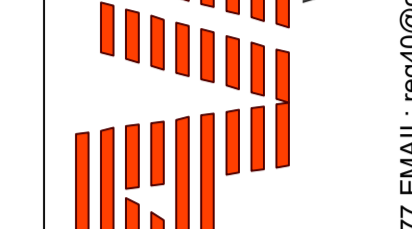
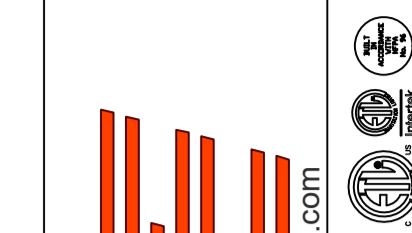

CHIPOTLE LOYOLA PEARSON #4272
109 E Pearson St,
Chicago, IL, 60611

DATE: 7/1/2022

DWG.#:
5274616DRAWN
BY: JMB-40SCALE:
3/4" = 1'-0"

MASTER DRAWING

SHEET NO.

3

www.captive.com

Highwoods Group

4641 Paragon Park Rd., Raleigh, NC, 27616 PHONE: (919) 875-0420 FAX: (919) 875-0577 EMAIL: reg10@captive.com

EXHAUST FAN INFORMATION – JOB#5274616

FAN UNIT NO	TAG	QTY	FAN UNIT MODEL #	MANUFACTURER	CFM	ESP	RPM	MOTOR ENCL	HP	BHP	PHASE	VOLT	FLA	WEIGHT (LBS)	SONES
1	EF-1	1	CFA 900CA	CAPTIVEAIRE	450	0.750	595	GENERALPURPOSE	0.410	0.3080	1	115	3.0	72	N/A
2	EF-2	1	CFA 500CA	CAPTIVEAIRE	180	0.800	738	GENERALPURPOSE	0.310	0.2290	1	115	2.2	40	N/A
3	EF-3	1	CFA 250CA	CAPTIVEAIRE	110	0.800	759	GENERALPURPOSE	0.222	0.1660	1	115	2.1	29	N/A

MUA FAN INFORMATION – JOB#5274616

FAN UNIT NO	TAG	QTY	FAN UNIT MODEL #	BLOWER	HOUSING	MIN CFM	DESIGN CFM	ESP	RPM	MOTOR ENCL	HP	BHP	PHASE	VOLT	FLA	MCA	MOCF	WEIGHT (LBS)	SONES
4	MAU-1	1	A2-D.500-20D	20MF-2-MDD	A2-D.500	2000	3740	0.800	1552	DDP, PREMIUM	3.000	2.0910	3	208	9.5	11.9A	20A	794	15.3

GAS FIRED MAKE-UP AIR UNIT(S)

FAN UNIT NO	TAG	INPUT BTUs	OUTPUT BTUs	TEMP RISE	REQUIRED INPUT GAS PRESSURE	GAS TYPE	BURNER EFFICIENCY(%)
4	MAU-1	301772	277630	71°F	7 IN. W.C. – 14 IN. W.C.	NATURAL	92

FAN OPTIONS

FAN UNIT NO	TAG	QTY	DESCRIPTION
1	EF-1	1	983L IN LINE KIT
		1	STRAIGHT THROUGH DISCHARGE – ASSEMBLY – CFA INLINE
		1	CEILING VIBRATION HANGERS
		1	FAN CONTROL – 6 AMP WHITE SPEED CONTROL FOR CFA FANS
		1	2 YEAR PARTS WARRANTY
2	EF-2	1	982L IN LINE KIT
		1	STRAIGHT THROUGH DISCHARGE – ASSEMBLY – CFA INLINE
		1	CEILING VIBRATION HANGERS
		1	FAN CONTROL – 3 AMP FAN MOUNTED SPEED CONTROL FOR CFA CEILING FANS
		1	2 YEAR PARTS WARRANTY
3	EF-3	1	981L IN LINE KIT
		1	STRAIGHT THROUGH DISCHARGE – ASSEMBLY – CFA INLINE
		1	CEILING VIBRATION HANGERS
		1	FAN CONTROL – 3 AMP FAN MOUNTED SPEED CONTROL FOR CFA CEILING FANS
		1	2 YEAR PARTS WARRANTY
4	MAU-1	1	INLET PRESSURE GAUGE, 0-35"
		1	MANIFOLD PRESSURE GAUGE, -5 TO 15" WC
		1	LOW FIRE START
		1	AC INTERLOCK RELAY – 24VAC COIL
		1	MOTORIZED BACKDRAFT DAMPER FOR A2-D HOUSING – MEETS AMCA CLASS 1A RATING
		1	INSULATION OPTION FOR VBANK FILTER SECTION
		1	DF2 INDOOR HANGING OPTION – INCLUDES 2 HSA125 HANGING SPRING ISOLATORS PER UNI-STRUT
		1	SEPARATE 120V WIRING PACKAGE (REQUIRED AND USED ONLY FOR DCV OR PREWIRE WITH VFD) – THREE PHASE ONLY
		1	SIZE 2 DIRECT FIRED HEATER LOW CFM PROFILE PACKAGE – USED ON HEATERS UNDER 2500 CFM
		1	UNIT MOUNTED VFD FOR USE WITH ECPM03
		1	2 YEAR PARTS WARRANTY

FAN ACCESSORIES

FAN UNIT NO	TAG	EXHAUST				SUPPLY		
		GREASE CUP	GRAVITY DAMPER	WALL MOUNT	SIDE DISCHARGE	GRAVITY DAMPER	MOTORIZED DAMPER	WALL MOUNT
1	EF-1							
2	EF-2							
3	EF-3							
4	MAU-1				YES		YES	

FAN #2 CFA 500CA – EXHAUST FAN (EF-2)

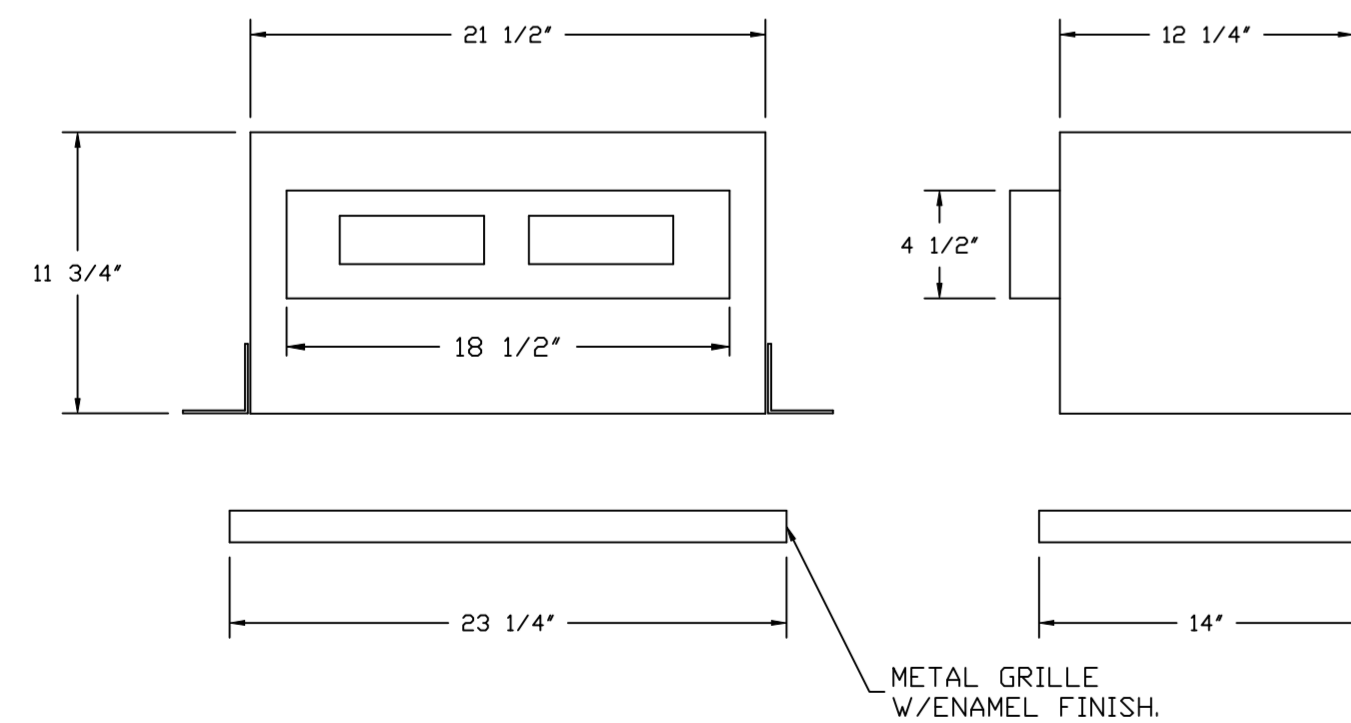

- FEATURES:**
- 1/2" ACOUSTIC HOUSING INSULATION.
 - 20 GA. GALVANIZED STEEL HOUSING.
 - PLUG TYPE DISCONNECT.
 - BUILD IN AUTOMATIC BACKDRAFT DAMPER.
 - AMCA SOUND & AIR CERTIFIED.
 - UL LISTED.
 - CAN BE INSTALLED IN CEILING OR WALL.
 - 8 POSITION MOUNTING BRACKETS.

- OPTIONS**
- 982L IN LINE KIT.
 - STRAIGHT THROUGH DISCHARGE – ASSEMBLY – CFA INLINE.
 - CEILING VIBRATION HANGERS.
 - FAN CONTROL – 3 AMP FAN MOUNTED SPEED CONTROL FOR CFA CEILING FANS.
 - 2 YEAR PARTS WARRANTY.

FAN #1 CFA 900CA – EXHAUST FAN (EF-1)

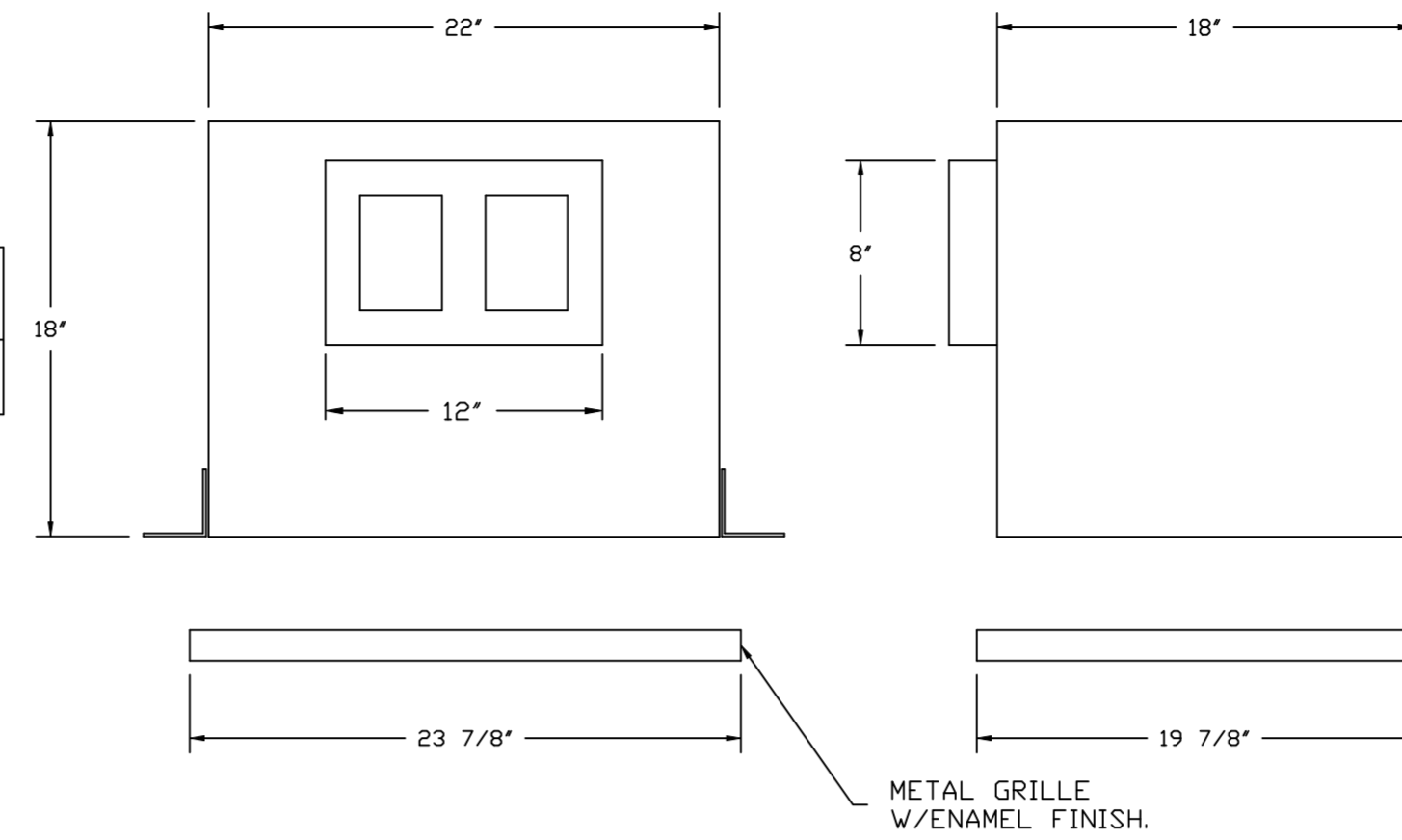

- FEATURES:**
- 1/2" ACOUSTIC HOUSING INSULATION.
 - 20 GA. GALVANIZED STEEL HOUSING.
 - PLUG TYPE DISCONNECT.
 - BUILD IN AUTOMATIC BACKDRAFT DAMPER.
 - AMCA SOUND & AIR CERTIFIED.
 - UL LISTED.
 - CAN BE INSTALLED IN CEILING OR WALL.
 - 8 POSITION MOUNTING BRACKETS.

- OPTIONS**
- 983L IN LINE KIT.
 - STRAIGHT THROUGH DISCHARGE – ASSEMBLY – CFA INLINE.
 - CEILING VIBRATION HANGERS.
 - FAN CONTROL – 6 AMP WHITE SPEED CONTROL FOR CFA FANS.
 - 2 YEAR PARTS WARRANTY.

FAN #3 CFA 250CA – EXHAUST FAN (EF-3)

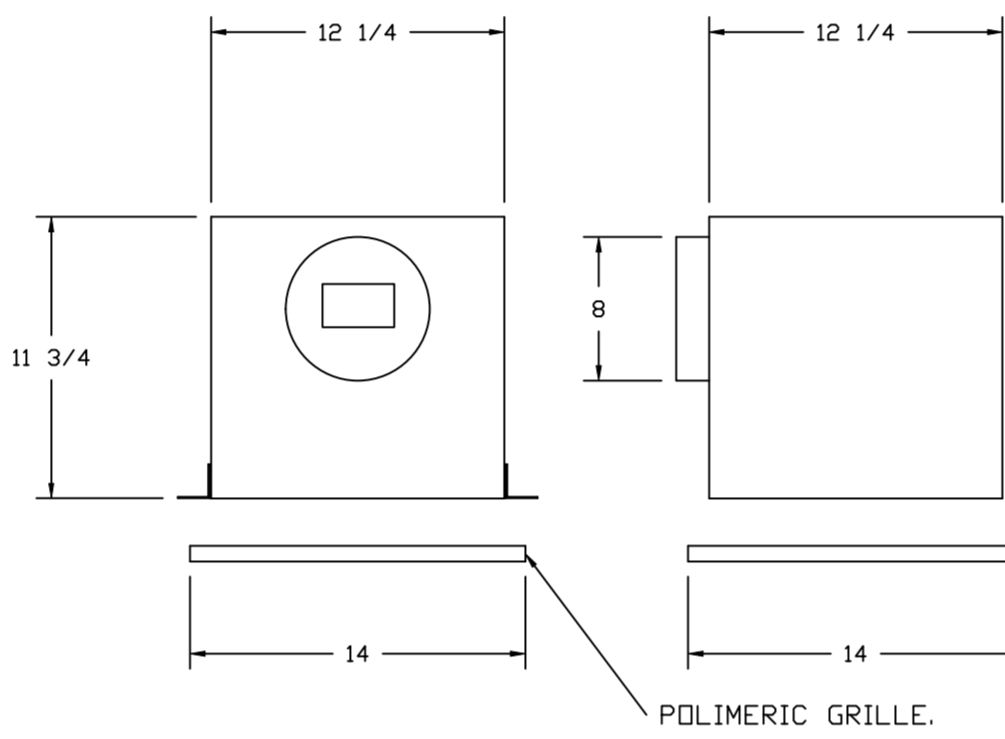

- FEATURES:**
- 1/2" ACOUSTIC HOUSING INSULATION.
 - 20 GA. GALVANIZED STEEL HOUSING.
 - PLUG TYPE DISCONNECT.
 - BUILD IN AUTOMATIC BACKDRAFT DAMPER.
 - AMCA SOUND & AIR CERTIFIED.
 - UL LISTED.
 - CAN BE INSTALLED IN CEILING OR WALL.
 - 8 POSITION MOUNTING BRACKETS.

- OPTIONS**
- 981L IN LINE KIT.
 - STRAIGHT THROUGH DISCHARGE – ASSEMBLY – CFA INLINE.
 - CEILING VIBRATION HANGERS.
 - FAN CONTROL – 3 AMP FAN MOUNTED SPEED CONTROL FOR CFA CEILING FANS.
 - 2 YEAR PARTS WARRANTY.

REVISIONS

DESCRIPTION	DATE

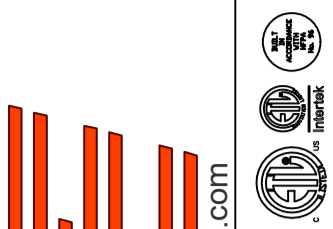

www.captiveaire.com
4641 Paragon Park Rd., Raleigh, NC, 27616 PHONE: (919) 875-0420 FAX: (919) 875-0577 EMAIL: reg40@captiveaire.com



CHIPOTLE LOYOLA PEARSON #4272
109 E Pearson St,
Chicago, IL, 60611

DATE: 7/1/2022

DWG.#:
5274616

DRAWN BY: JMB-40

SCALE:
3/4" = 1'-0"

MASTER DRAWING

SHEET NO.

- FAN #4 A2-D500-20D - HEATER (MAU-1)
1. DIRECT GAS FIRED HEATED MAKE UP AIR UNIT WITH 20" MIXED FLOW DIRECT DRIVE FAN.
 2. V-BANK EZ FILTERS - INDOOR.
 3. SIDE DISCHARGE - AIR FLOW RIGHT -> LEFT.
 4. GAS PRESSURE GAUGE, 0-35", 2.5" DIAMETER, 1/4" THREAD SIZE.
 5. GAS PRESSURE GAUGE, -5 TO +15 INCHES WC, 2.5" DIAMETER, 1/4" THREAD SIZE.
 6. LOW FIRE START, ALLOWS THE BURNER CIRCUIT TO ENERGIZE WHEN THE MODULATION CONTROL IS IN A LOW FIRE POSITION.
 7. COOLING INTERLOCK RELAY, 24VAC COIL, 120V CONTACTS, LOCKS OUT BURNER CIRCUIT WHEN AC IS ENERGIZED.
 8. MOTORIZED BACK DRAFT DAMPER 22.75" X 24" FOR SIZE 2 STANDARD & MODULAR HEATER UNITS W/EXTENDED SHAFT, STANDARD GALVANIZED CONSTRUCTION, 3/4" REAR FLANGE, LOW LEAKAGE, LF120S ACTUATOR INCLUDED.
 9. "INSULATION" FOR V-BANK INTAKE OPTION.
 10. INDOOR HANGING CRADLE FOR THE SIZE 2 DIRECT FIRED UNIT, 2 HSA125 HANGING ISOLATORS PER UNI-STRUT INCLUDED.
 11. SEPARATE 120VAC WIRING PACKAGE FOR MAKE-UP AIR UNITS. OPTION MUST BE SELECTED WHEN MOUNTING VFD IN PREWIRE PANEL OR WITH DCV PACKAGE. PROVIDES SEPARATE 120VAC INPUT TO SUPPLY FAN. THIS 120V SIGNAL MUST BE RUN BY ELECTRICIAN FROM DCV TO MUA SWITCH.
 12. PROFILE PLATE CONFIGURATION FOR SIZE 2 DIRECT FIRED UNIT FOR LOW CFM APPLICATIONS.
 13. UNIT MOUNTED VFD FOR USE WITH ECPM03.
 14. HINGED DOUBLE WALL INSULATED DOOR ASSEMBLY (BURNER/BLOWER SECTION).
 15. 2 YEAR PARTS WARRANTY.

NOTE: SUPPLY DUCT MUST BE INSTALLED TO MEET SMACNA STANDARDS. A MINIMUM STRAIGHT DUCT LENGTH MUST BE MAINTAINED DOWNSTREAM OF UNIT DISCHARGE AS OUTLINED IN AMCA PUBLICATION 201. WHEN USING RECTANGULAR DUCTWORK, ELBOWS MUST BE RADIUS THROAT, RADIUS BACK WITH TURNING VANES. FLEXIBLE DUCTWORK AND SQUARE THROAT/SQUARE BACK ELBOWS SHOULD NOT BE USED. ANY TRANSITION AND/OR TURNS IN THE DUCTWORK WILL CAUSE SYSTEM EFFECT, SYSTEM EFFECT WILL DRASTICALLY INCREASE STATIC PRESSURE AND REDUCE AIRFLOW. DO NOT RELY ON UNIT TO SUPPORT DUCT IN ANY WAY. FAILURE TO PROPERLY SIZE DUCTWORK MAY CAUSE SYSTEM EFFECTS AND REDUCE PERFORMANCE OF THE EQUIPMENT. SUGGESTED STRAIGHT DUCT SIZE IS 26" x 26".

SUPPLY SIDE HEATER INFORMATION:
 WINTER TEMPERATURE = 4°F. TEMP. RISE = 71°F.
 BTUs CALCULATED OFF ACTUAL AIR DENSITY.
 OUTPUT BTUs AT ALTITUDE OF 0.0 FT. = 283687.
 INPUT BTUs AT ALTITUDE OF 0.0 FT. = 308355.
 OUTPUT BTUs AT ALTITUDE OF 596 FT. = 277630.
 INPUT BTUs AT ALTITUDE OF 596 FT. = 301772.

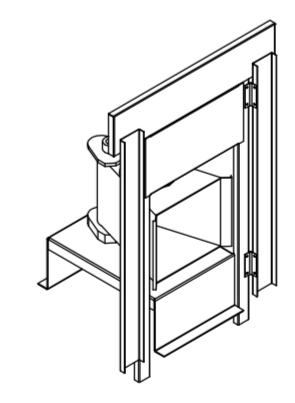
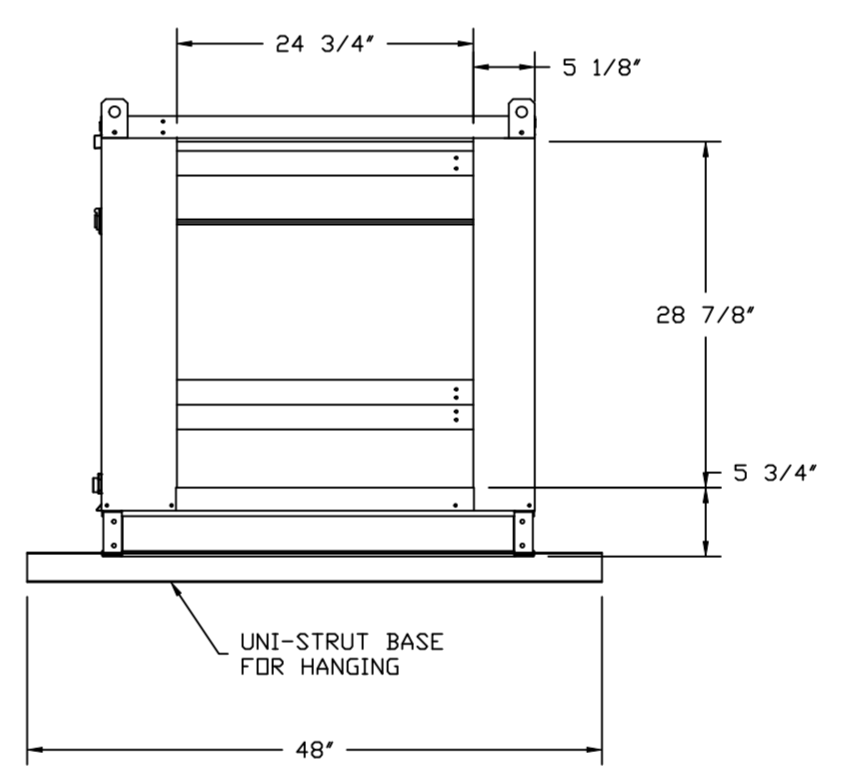
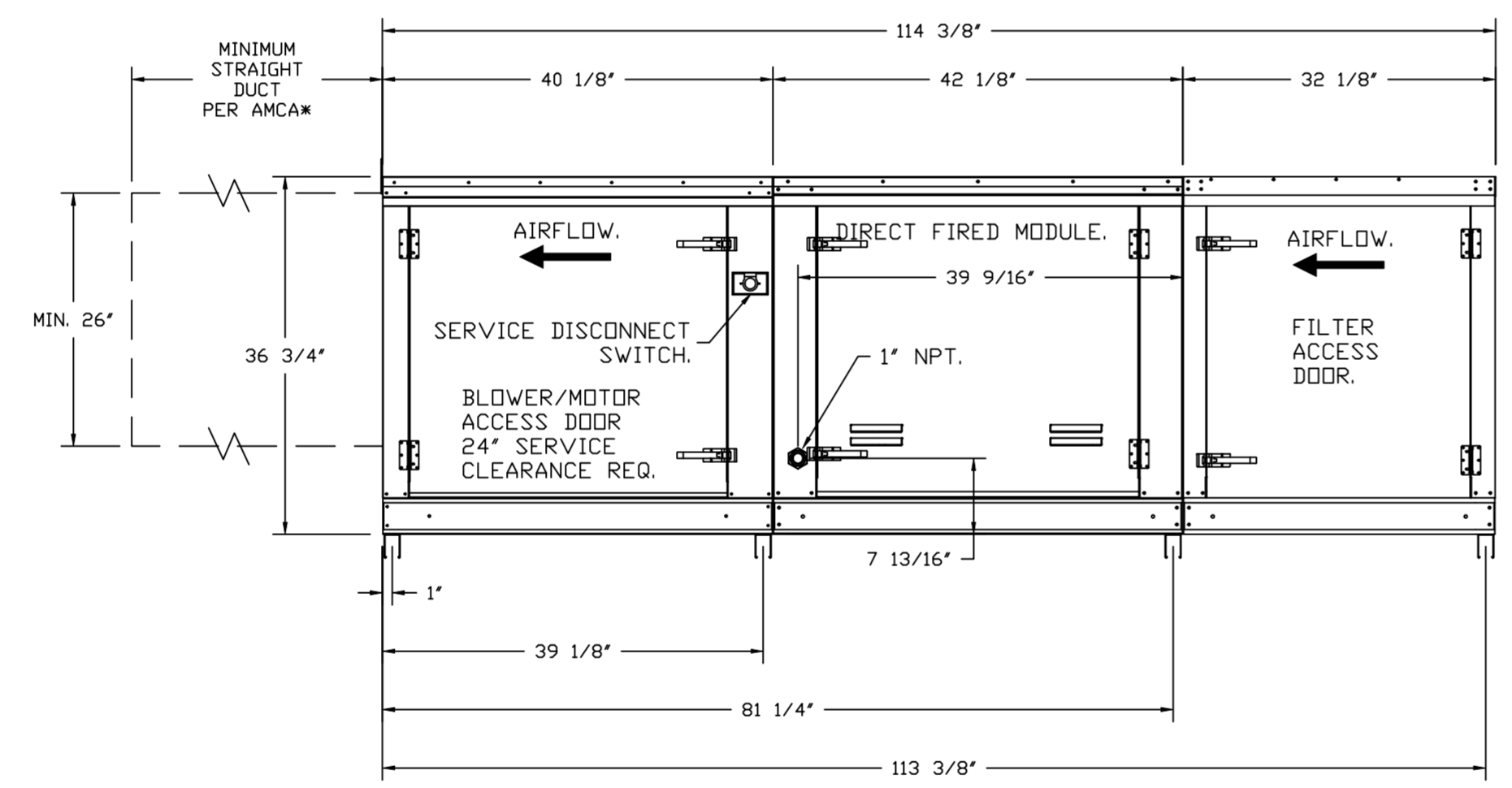
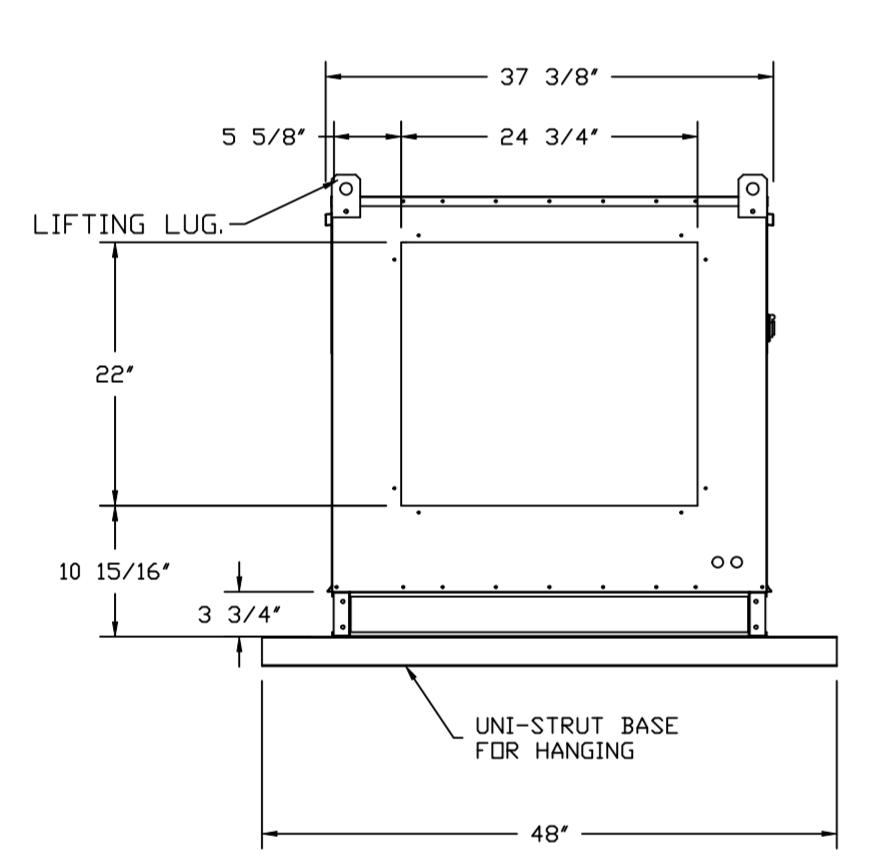
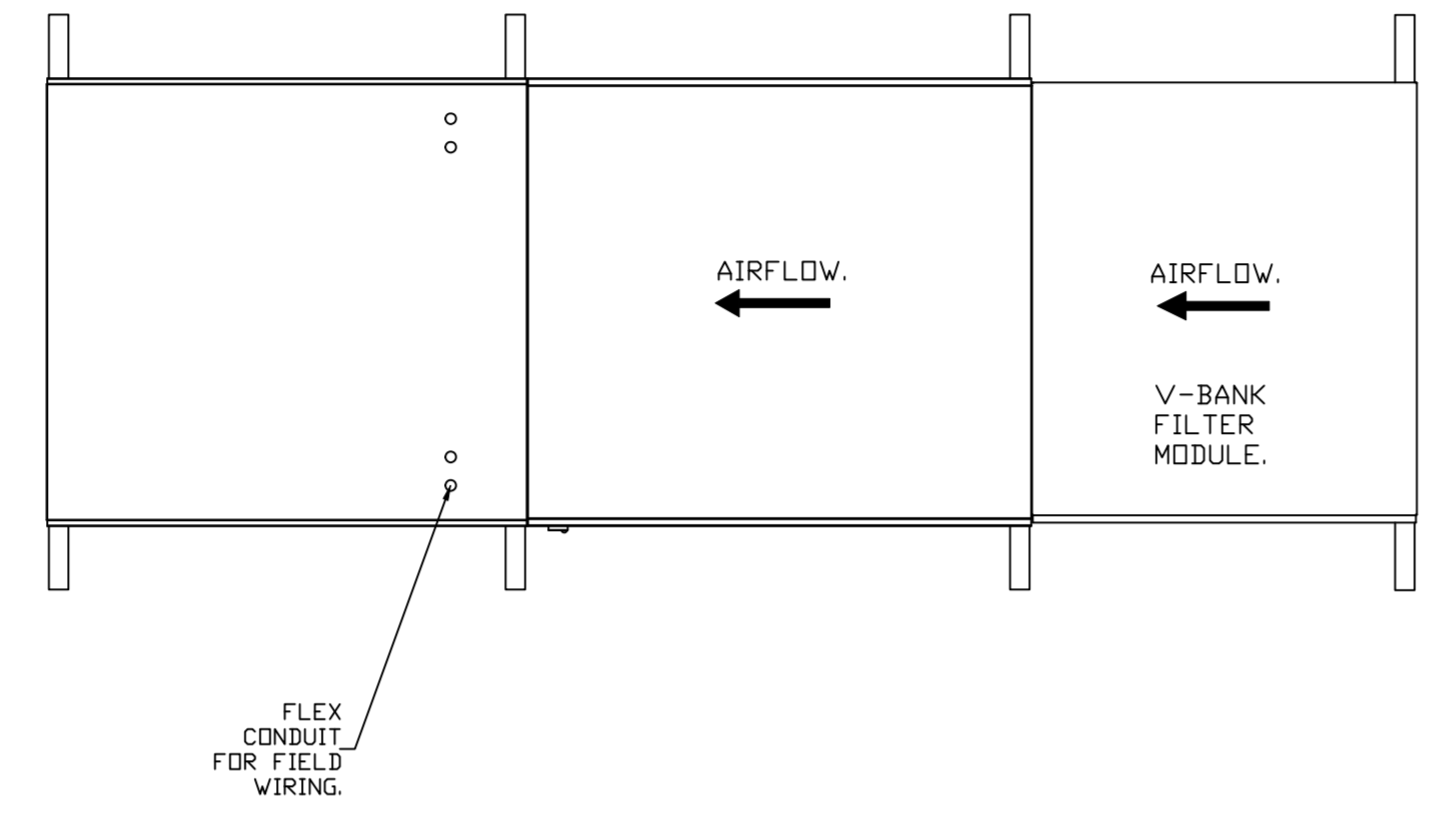

DIRECT FIRED (DF) PROFILE PLATE ASSEMBLY

DESCRIPTION:
 DIRECT FIRED BURNERS SHALL HAVE PATENTED (US PATENT NO. US6629522B2), SELF-ADJUSTING PROFILE PLATES DESIGNED TO ENSURE PROPER AIR VELOCITY AND PRESSURE DROP ACROSS THE BURNER. PROFILE PLATES SHALL ALLOW BURNERS TO ACHIEVE CLEAN COMBUSTION BY LIMITING BY-PRODUCT LEVELS TO A MAXIMUM OF 95PPM OF CARBON MONOXIDE (CO) AND 400PPM OF NITROGEN DIOXIDE (NO2). DIRECT FIRED UNITS SHALL BE CONFIGURED WITH THE BLOWER MOUNTED DOWNSTREAM OF THE BURNER. THIS ARRANGEMENT WILL ENSURE A CONSISTENT AIRFLOW, REGARDLESS OF INLET AIR TEMPERATURE.

APPLICATION:
 SPRING-LOADED BURNER PROFILE PLATES ARE ENGINEERED TO AUTOMATICALLY REACT TO THE MOMENTUM OF A FRESH AIR STREAM, WITHOUT THE NEED FOR ANY MOTORS OR ACTUATORS TO MECHANICALLY ADJUST THEM. WITH THIS FEATURE, ALL DF UNITS ARE DESIGNED FOR DEMAND CONTROL VENTILATION (DCV) REQUIREMENTS.

CERTIFICATIONS:
 ALL PROFILE PLATE ASSEMBLIES SHALL BE INCLUDED IN THE DF UNIT'S ETL LISTING AND COMPLY WITH COMBINED SAFETY STANDARDS ANSI Z83.4 AND CSA 3.7 (NON-RECIRCULATING DF HEATERS) AND ANSI Z83.8 (RECIRCULATING DF HEATERS).

GENERAL CONSTRUCTION:
 -PROFILE PLATES SHALL BE FORMED FROM G90 GALVANIZED STEEL.
 -PROFILE PLATES SHALL VARY IN SIZE PER UNIT.
 -PROFILE PLATES SHALL BE MOUNTED ALONG THE SAME PLANE AS THE DISCHARGE OF THE BURNER.
 -DESIGN SHALL INCORPORATE PROPERLY TORQUED, PERMANENTLY MOUNTED SPRING HINGES.
 -SPRING HINGES SHALL BE MADE FROM PLATED STEEL.

REVISIONS

DESCRIPTION	DATE

CAPTIVE

Highwoods Group

4641 Paragon Park Rd., Raleigh, NC, 27616 PHONE: (919) 875-0420 FAX: (919) 875-0577 EMAIL: reg10@captivair.com

CHIPOTLE LOYOLA PEARSON #4272

109 E Pearson St,
 Chicago, IL, 60611

DATE: 7/1/2022

DWG.#:
 5274616

DRAWN BY: JMB-40

SCALE:
 3/4" = 1'-0"

MASTER DRAWING

SHEET NO.
 5

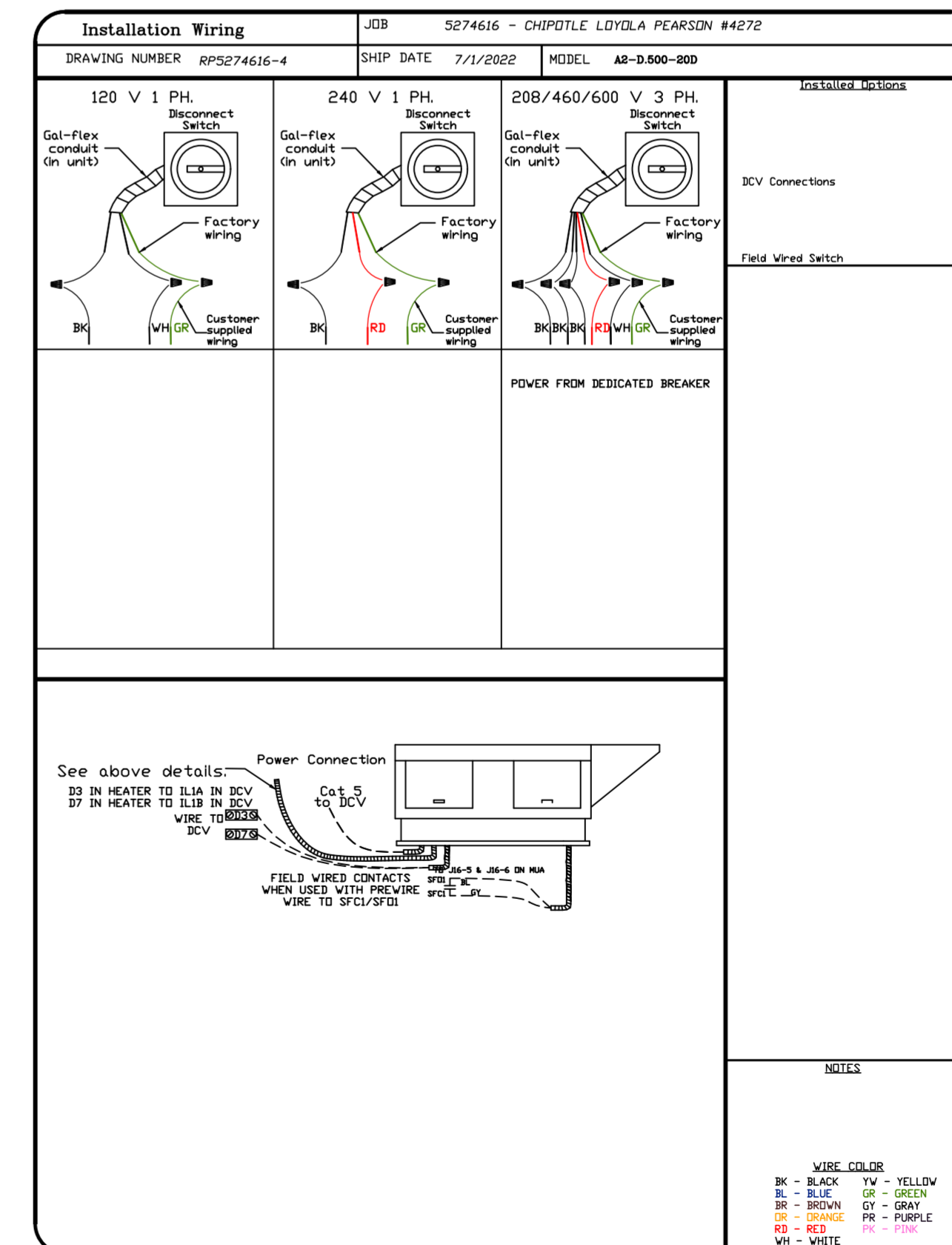
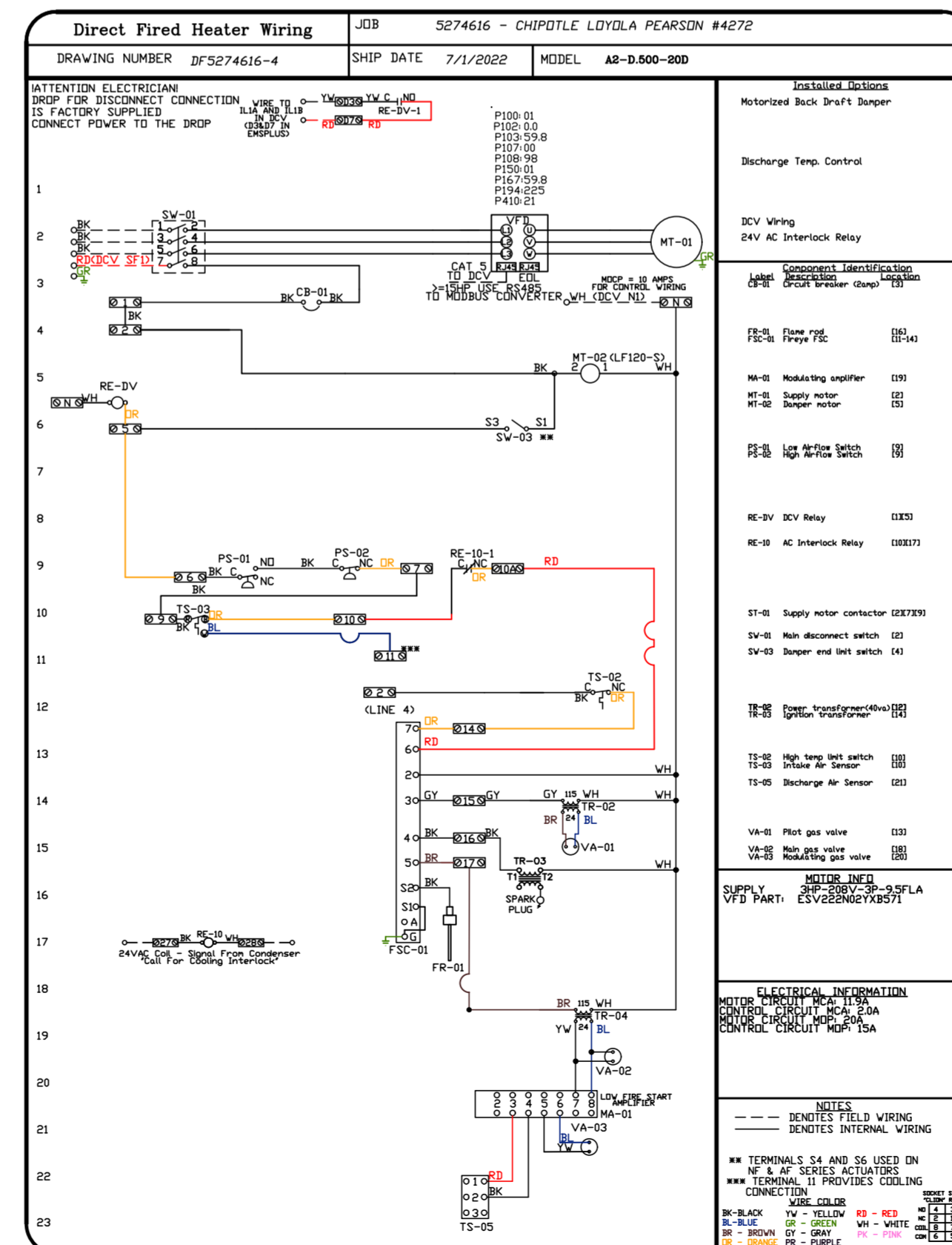
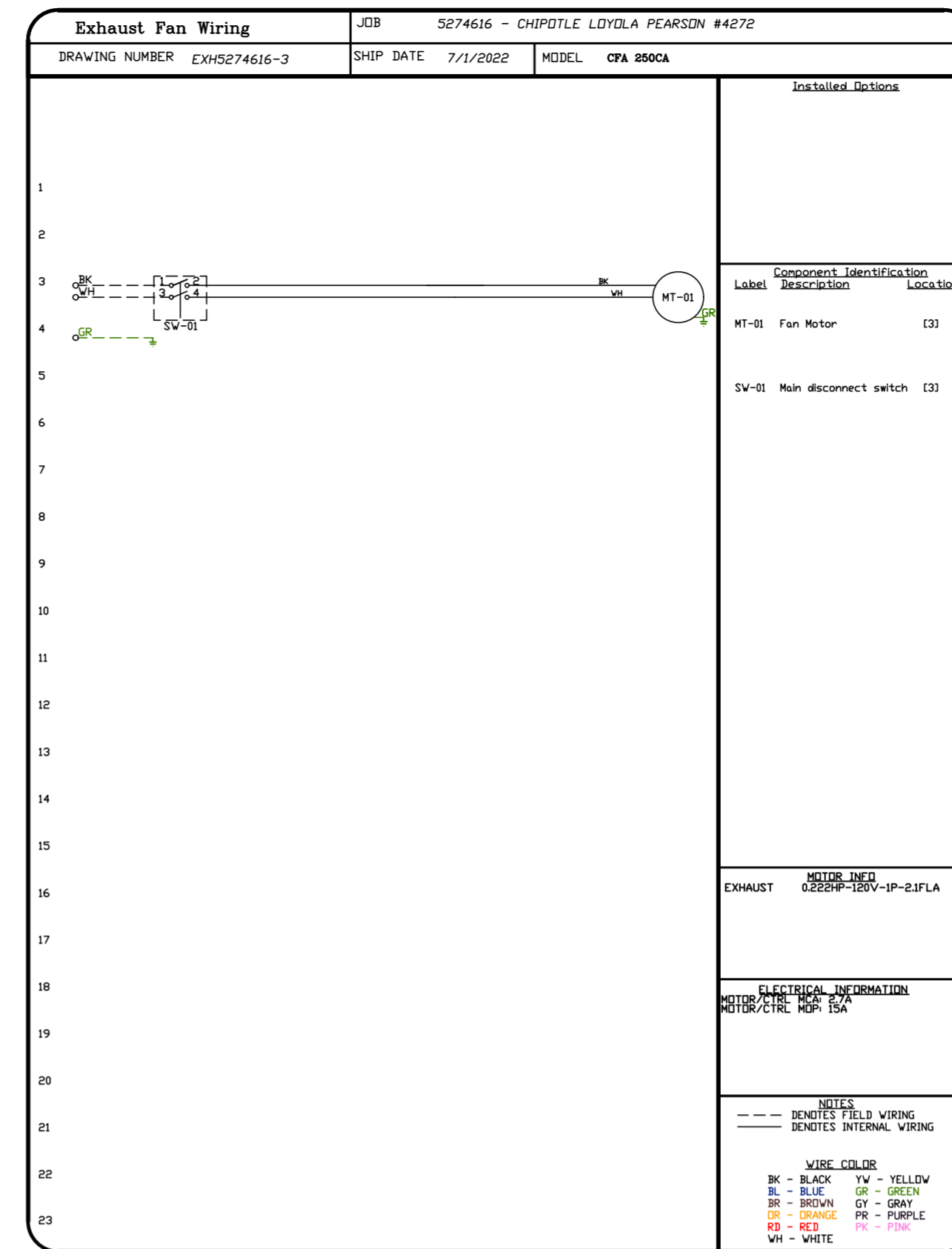
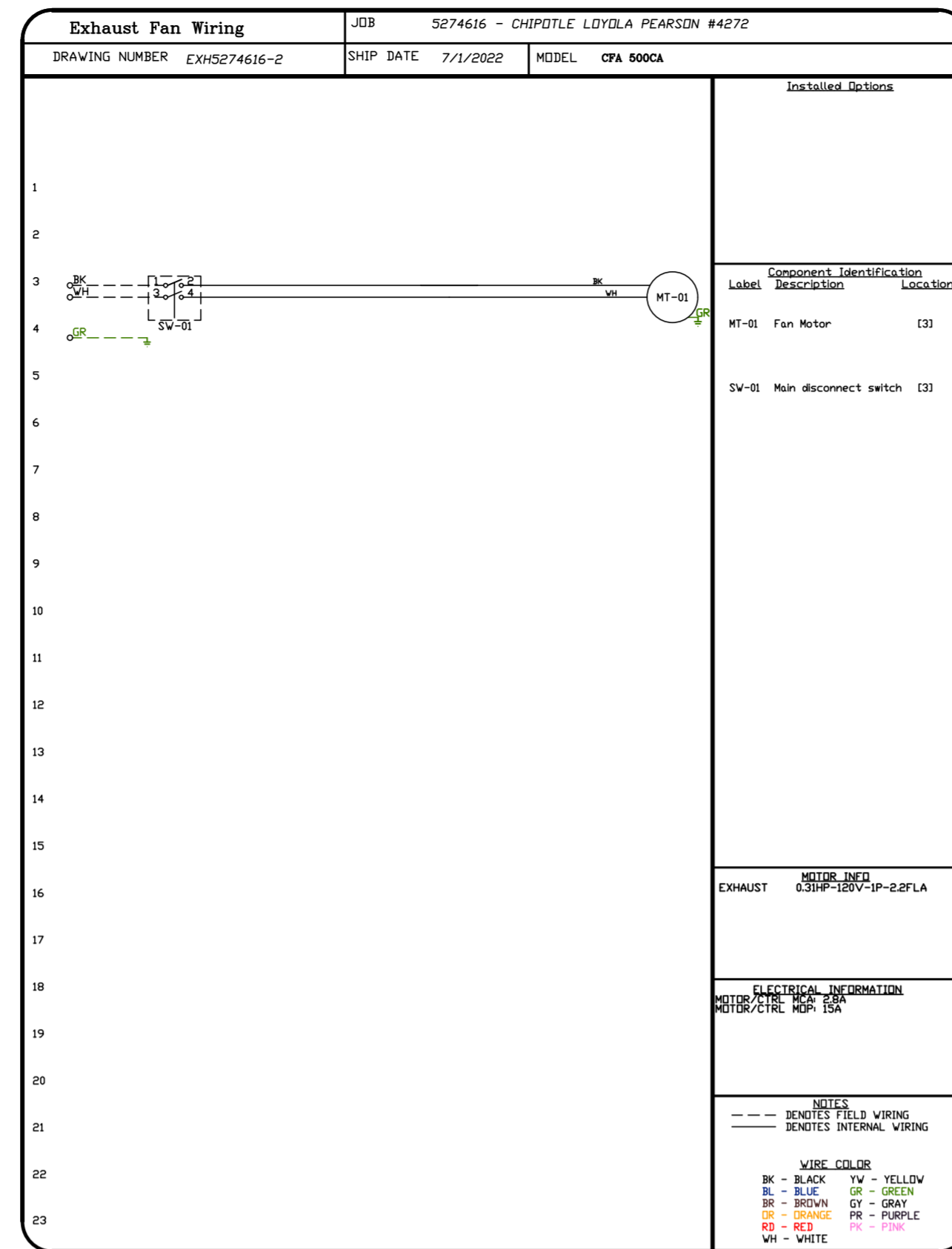
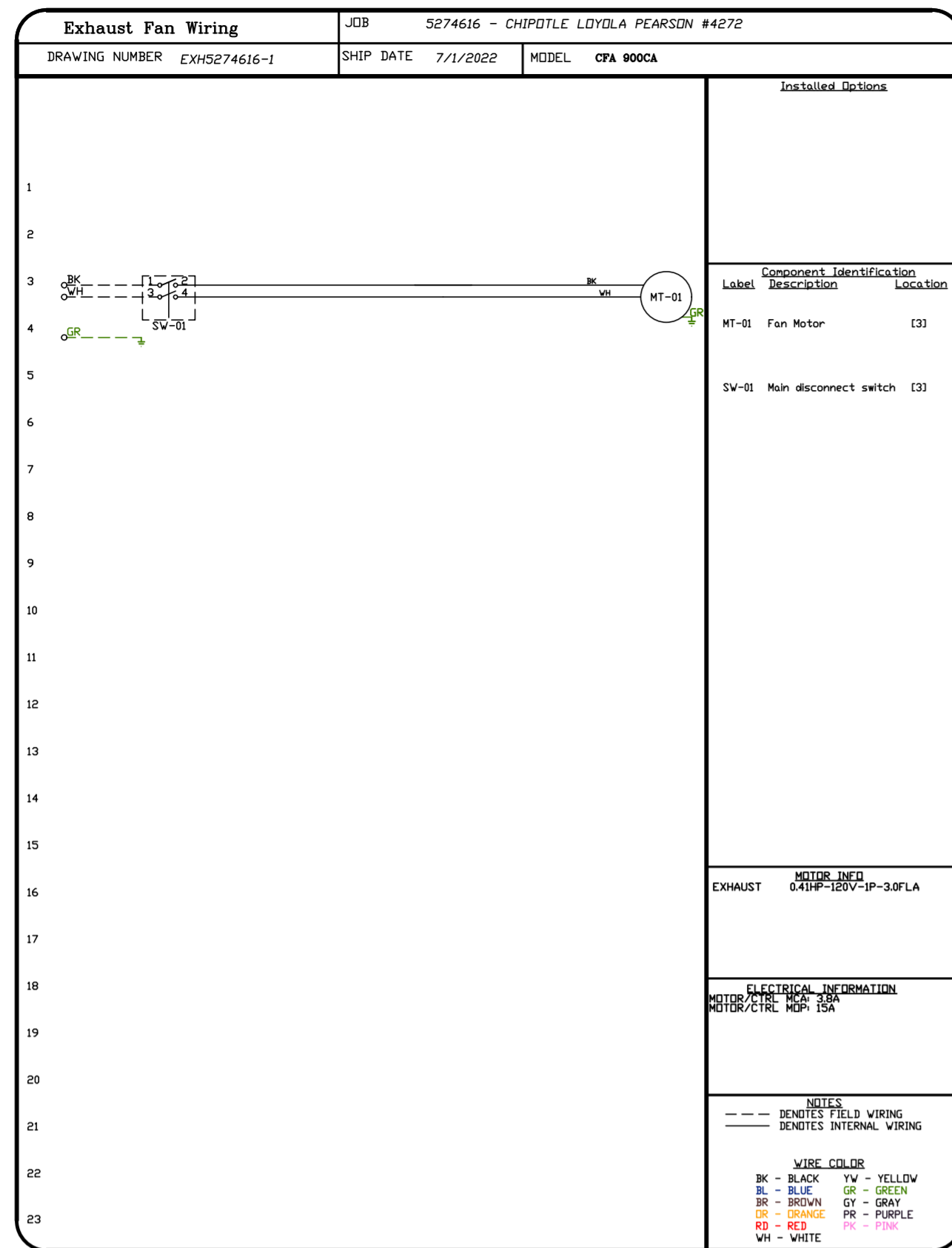

REVISIONS	
DESCRIPTION	DATE

www.captive.com
 Highwoods Group
 4641 Paragon Park Rd., Raleigh, NC 27616 PHONE: (919) 875-0420 FAX: (919) 875-0577 EMAIL: reg10@captive.com

CHIPOTLE LOYOLA PEARSON #4272
 109 E Pearson St,
 Chicago, IL, 60611

DATE: 7/1/2022
 DWG.#:
 5274616
 DRAWN BY: JMB-40
 SCALE:
 3/4" = 1'-0"
 MASTER DRAWING

SHEET NO.
 6

