

Direct Drive Upblast Centrifugal Roof Exhaust Fan

MARK INFORMATION		FAN INFORMATION								SOUND INFORMATION				MOTOR INFORMATION										
MARK	QTY	MODEL	DRIVE TYPE	VOLUME (CFM)	EXTERNAL SP (IN. WG)	TOTAL EXTERNAL SP (IN. WG)	FAN SPEED (RPM)	OUTLET VELOCITY (FT/MIN)	FEI	TOTAL WEIGHT (LB)	INLET dBA	INLET SONES	INLET SONES (SPHERICAL)	OUTLET dBA	OUTLET SONES	OPERATING POWER (HP)	MOTOR SIZE (HP)	FEP INPUT POWER (KW)	ENCLOSURE	VOLTAGE	CYCLE	PHASE	EC MOTOR	NEC FLA*
EF-1 (Hood-1)	1	XCUE-160-VG	Direct	2,550	1.2	1.2	1,330	1,482.56	1.4	106	68.74	16.82	0	0	0	0.87	2	0.78	TF	208	60	1	VariGreen	13.2

*NEC FLA - Based on table 430.250 or 430.248 of National Electrical Code 2020. Actual motor FLA may vary for sizing thermal overload, consult factory"

EF-1 (Hood-1) : SELECTED OPTIONS AND ACCESSORIES

One piece fully welded windband
 Tapered bushing wheel hub
 Breather tube outlet area min. 4.4 sq. in. (sizes 99-480), 2.0 sq. in. (sizes 60-95)
 Min. windband material thickness: 0.051" aluminum (060-240), 0.064" aluminum (240HP, 240XP), 0.080" aluminum (sizes 300-480)
 Larger Curb Cap Size - 26 Square
 UL/cUL 705 Listed - Supplement SC - "Power Ventilators for Restaurant Exh. Appliances" (Formerly UL 762)
 Switch, NEMA-3R, Toggle,
 Aluminum Wheel Material

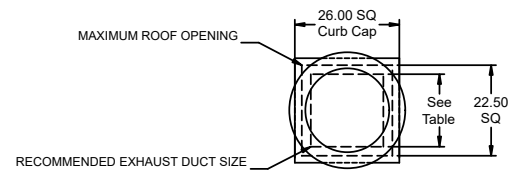

DUCT TYPE	SIZE
STANDARD	18 SQ
FIRE-WRAPPED	12 SQ

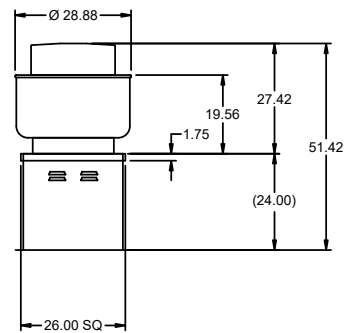

DUCT DIMENSIONS ARE LARGEST POSSIBLE DUCT TO FIT THROUGH CURB.
 CONSULT SYSTEM DESIGN ENGINEER FOR RECOMMENDED DUCT SIZE.

OVERALL HEIGHT MAY BE GREATER DEPENDING ON
 MOTOR, ADAPTER, AND/OR HINGE BASE.

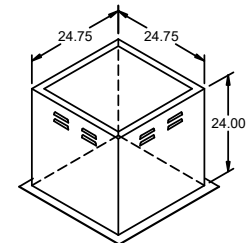

CHIPOTLE-JOSEY & PARKER
 5277

PROJECT
 12/22/2024

MARK
 EF-1 (HOOD-1)

DIRECT CHAIN ACX
 JOE - AYUB
 JOE.AYUB@ACCUREX.COM
 (857)272-8727

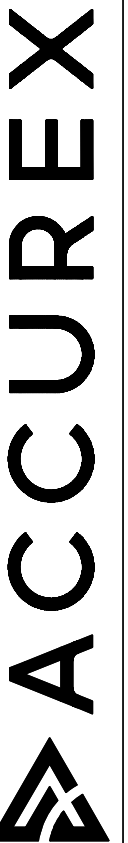

HOOD INFORMATION																	
HOOD NO.	MARK	MODEL	HOOD DIMENSIONS (IN.)			HOOD CONSTR.	COOKING LOAD / DUTY RATING	EXHAUST					SUPPLY		HANGING WEIGHT LBS.	SECTION LOCATION	
			LENGTH	WIDTH	HEIGHT			TOTAL CFM	COLLAR(S)			MUA CFM	AC CFM				
1	HOOD-1	XXEW-153-S	153	54	24	430 SS WHERE EXPOSED	HEAVY	2550	10	24		2550	0.483	1300	700	732	SINGLE

HOOD INFORMATION														
HOOD NO.	MARK	LIGHTING DETAILS				GREASE FILTRATION DETAILS				UTILITY CABINET(S)				
		FIXTURE TYPE	BULB / LAMP INFO	QTY	FOOT CANDLES	TYPE / MODEL MATERIAL	QTY	SIZE (IN.) L H	LOCATION	FIRE SYSTEM TYPE	SIZE	MODEL	CONTROLS INTERFACE	
1	HOOD-1	INCANDESCENT (GLOBE)	100W A19 (BULBS NOT INCL.)	8	54.77	X-TRACTOR (SPARK ARRESTOR INCL.) STAINLESS STEEL	2	16 20	20	RIGHT	ANSUL R102	6	XKC	TOUCHSCREEN

SUPPLY PLENUM INFORMATION																		
HOOD NO.	MARK	POS.	TYPE	SIZE (IN.)			INSULATED	DAMPER(S)	LED LIGHT(S)		TOTAL CFM	TOTAL S.P.	COLLARS					
				L	W	H			SUPPLIED	QTY			TYPE	MOUNTING	QTY	W	L	DIA.
1	HOOD-1	FRONT	SPLIT ASF	82.5	14	4	NO	NO		650	0	MUA	FACTORY	2	12	28	325	139
				82.5	10	4	YES	YES		350	0.02	AC	FACTORY	3			117	335
1	HOOD-1	FRONT	SPLIT ASF	82.5	14	4	NO	NO		650	0	MUA	FACTORY	2	12	28	325	139
				82.5	10	4	YES	YES		350	0.02	AC	FACTORY	3			117	335

HOOD OPTIONS

- UL 710 LISTED W/ OUT EXHAUST FIRE DAMPER - UL #R25625
- BACK INTEGRAL AIR SPACE - 3 IN WIDE - ZERO CLEARANCE
- 10 IN HIGH CEILING ENCLOSURES - FRONT LEFT RIGHT - FIELD INSTALLED
- FACTORY MOUNTED EXHAUST COLLAR(S)
- LEFT INSULD END PNL W/ ADJ LEG 80 IN HIGH 27.00 IN TOP WIDTH 21.0 IN BOTTOM WIDTH
- RIGHT INSULD END PNL W/ ADJ LEG 80 IN HIGH 27.00 IN TOP WIDTH 21.0 IN BOTTOM WIDTH
- PERFORMANCE ENHANCING LIP (PEL) TECHNOLOGY
- STANDING SEAM CONSTRUCTION FOR SUPERIOR STRENGTH

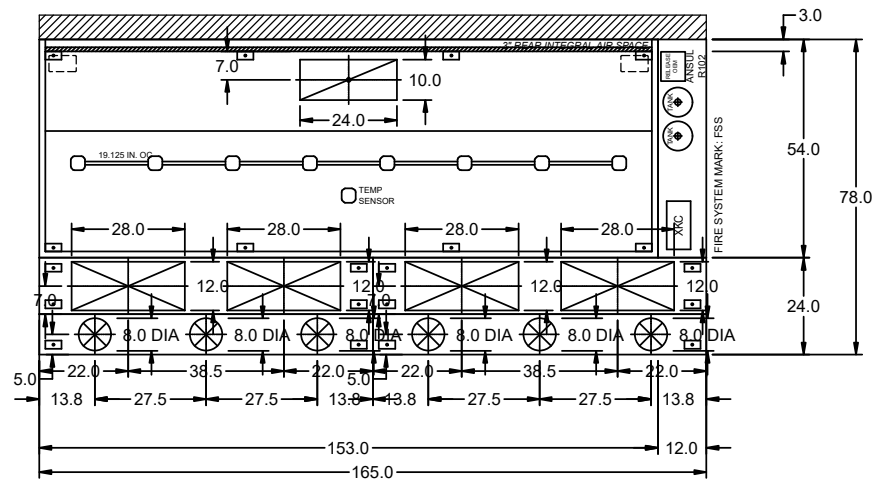

MARK: Hood-1 - SECTION 1
PLAN VIEW

FIRE (PIPING/DROPS/NOZZLES/ETC.)
SUBJECT TO CHANGE. AS-BUILT
DRAWINGS CAN BE PROVIDED AT
TIME OF ORDER AND INCLUDED
WITH PRODUCT SHIPMENT

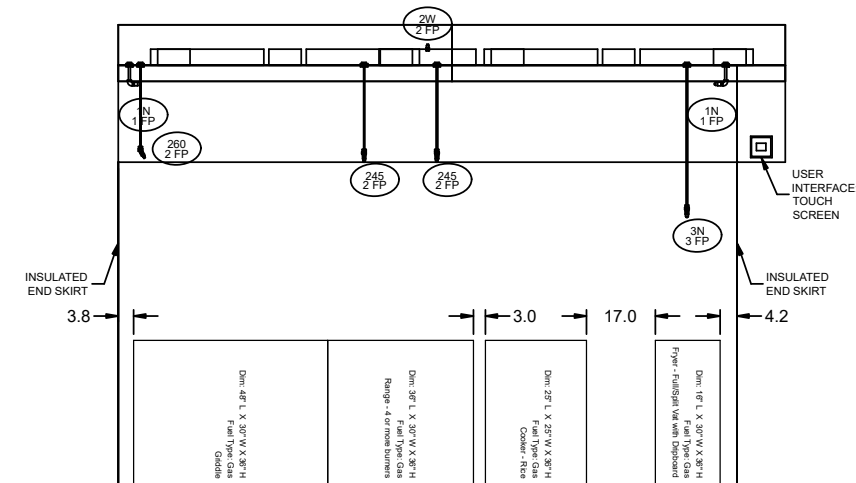

MARK: Hood-1 - SECTION 1
ELEVATION VIEW

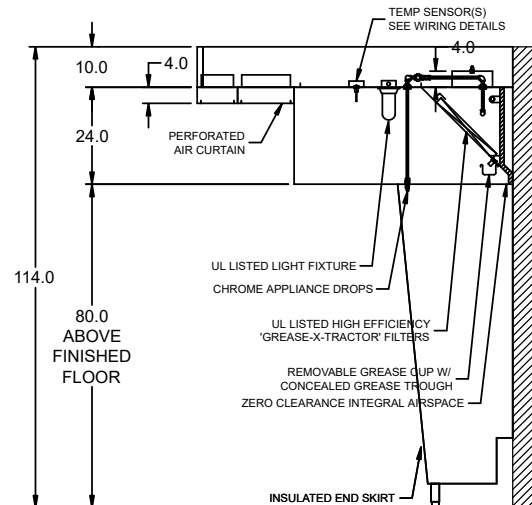

MARK: Hood-1
SECTION VIEW

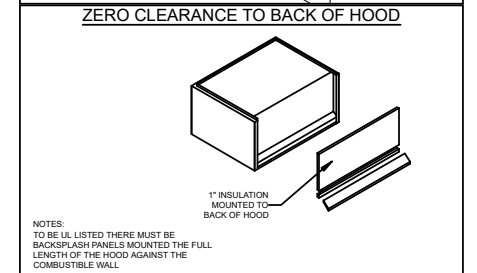
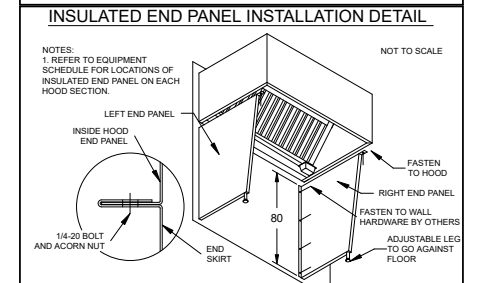
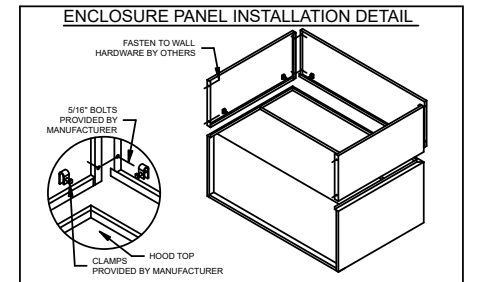

HOOD HANGING HEIGHT FOR FIRE SYSTEMS
VERIFICATION OF HOOD HANGING HEIGHT ABOVE FINISHED FLOOR (A.F.F.) IS REQUIRED FOR CORRECT PLACEMENT OF FIRE SYSTEM NOZZLES.

- RECOMMENDED HANGING HEIGHT = 80" FROM FINISHED FLOOR TO LOWER FRONT EDGE OF HOOD.
- OTHER HANGING HEIGHT = * FROM FINISHED FLOOR TO LOWER EDGE OF HOOD.

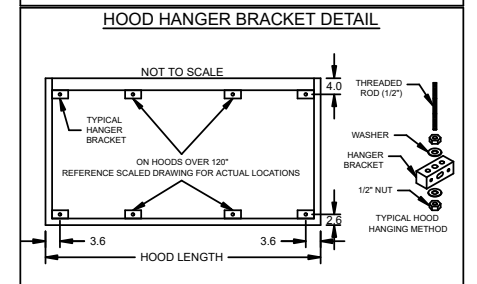
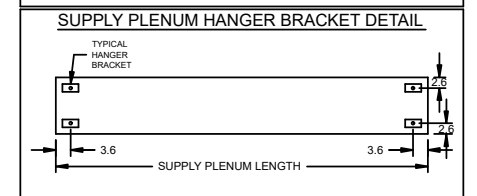

Direct Drive Centrifugal Roof Exhaust Fan

MARK INFORMATION		FAN INFORMATION									SOUND INFORMATION				MOTOR INFORMATION									
MARK	QTY	MODEL	DRIVE TYPE	VOLUME (CFM)	EXTERNAL SP (IN. WG)	TOTAL EXTERNAL SP (IN. WG)	FAN SPEED (RPM)	OUTLET VELOCITY (FT/MIN)	FEI	TOTAL WEIGHT (LB)	INLET dBA	INLET SONES	INLET SONES (SPHERICAL)	OUTLET dBA	OUTLET SONES	OPERATING POWER (HP)	MOTOR SIZE (HP)	FEP INPUT POWER (KW)	ENCLOSURE	VOLTAGE	CYCLE	PHASE	EC MOTOR	NEC FLA*
EF-2 (Restroom)	1	XRED-097-VG	Direct	150	0.6	0.6	1,330	156.25	0	43.2	51.87	6.22	0	0	0	0.05	0.25	0	TN	115	60	1	VariGreen	5.8

*NEC FLA - Based on table 430.250 or 430.248 of National Electrical Code 2020. Actual motor FLA may vary for sizing thermal overload, consult factory"

EF-2 (Restroom) : SELECTED OPTIONS AND ACCESSORIES
Standard Curb Cap Size - 19 Square UL/cUL 705 Listed - "Power Ventilators" Switch, NEMA-1, Toggle, Damper Shipped Loose, BD-100-PB-12X12, Gravity Operated, Not Coated, Nominal Size Birdscreen: Galvanized, nom. 84% Free Area Conduit Chase Qty 1

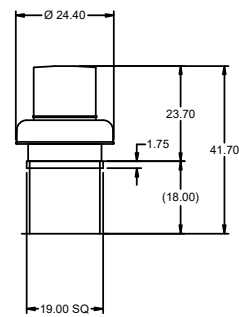
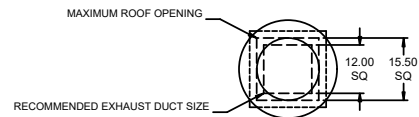

DUCT DIMENSIONS ARE LARGEST POSSIBLE DUCT TO FIT THROUGH CURB.
CONSULT SYSTEM DESIGN ENGINEER FOR RECOMMENDED DUCT SIZE.

OVERALL HEIGHT MAY BE GREATER DEPENDING ON MOTOR, ADAPTER, AND/OR HINGE BASE.

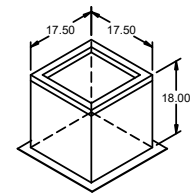
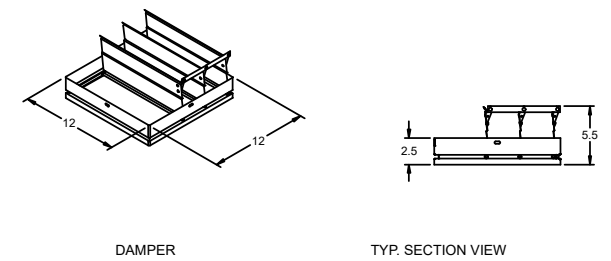

CHIPOTLE-JOSEY & PARKER
5277

PROJECT
12/22/2024

MARK

EF-2 (RESTROOM)

DIRECT CHAIN ACX
JOE AYOUB
JOE.AYOUB@ACCUREX.COM
(857)272-8727

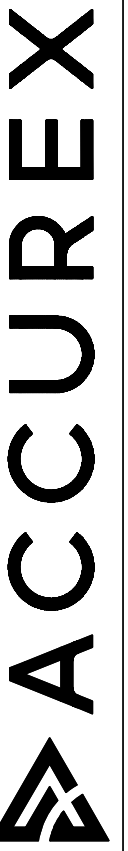

EQUIPMENT SCHEDULE										OPTIONS AND ACCESSORIES									
Tempered Make-Up Air Unit										Air Flow Arrangement: Outdoor Air Only Weatherhood: Aluminum Mesh, 16x20x2 - (2) Dampers: Inlet Outdoor Air Intake Position: End Discharge Position: Bottom Coating: Galvanized Insulation: Double Wall - Tempering On Supply Fan Control: Vari-Green ECM Vari-Green Control: Dial on Motor Access Side: Right-Hand Unit Weight: 421 lb Control Center Heat Inlet Air Sensor External Cooling Lockout Relay Unit Controls: Terminal Strip Temperature Control: Discharge Direct Gas Options/Accessories Approvals: ETL FM Compliant Flame Sensing: Flame Rod Ignition Control: Pilot									
Qty	Accurex Model	Volume	External SP	Total SP	MCA	MOP	Weight	SCCR	Mark: MAU-1										
1	XDGX-P115-H05-VG	1,300 CFM	0.5 in. wg	1,446 in. wg	21.3	35	421 lb	5kA											
Motor Information																			
Size	V/CP	Enclosure	Motor with Shaft Grounding	Motor RPM	Operating Power														
1 hp	115/60/1	ODP	No	1725	0.68 hp														
Heating																			
Type	Gas Type	Temperature	Energy	Connection	Building	Control	Gas Pressure												
Direct Gas	Natural	Winter DB Max Δ Max LAT	Input Output Efficiency	Gas (IN)	Pressure	Access	Min Max												
		10.0 F 60.0 F 70.0 F	91.6 MBH 84.2 MBH 92%	3/4"	1/2 PSI	Right Hand	7 in. wg 0.5 PSI												

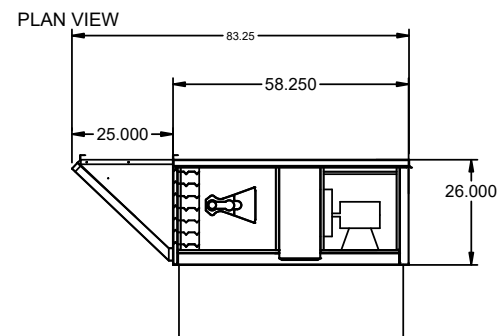
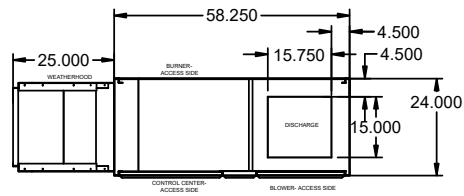

ELEVATION VIEW

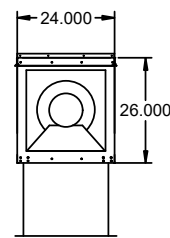

END VIEW

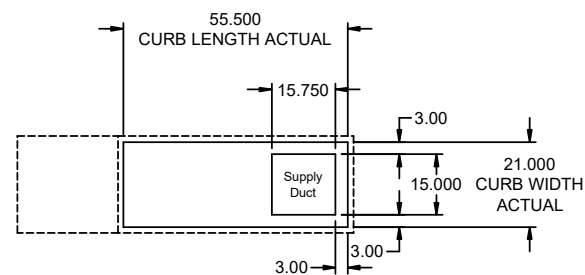

FOOTPRINT

NOTE: Roof Opening Requirements:

Minimum Roof Opening: The minimum roof opening size is the illustrated duct diameter plus 0.25 in. on all sides. For example: If the duct size is 14 x 14 in. square, the minimum roof opening size is 14.5 x 14.5 in. square.

Maximum Roof Opening: There must be a minimum perimeter of 1.75 in. between the roof opening and the roof curb. For example: If the roof curb is 75 x 30 in. square, the maximum roof opening is 71.5 x 26.5 in. inches square.

NOTE: The weatherhood and filter sections of the make-up air unit are not supported by the curb. This is by design, in order to help alleviate water infiltration issues. MUA Unit supports are shipped loose with unit.

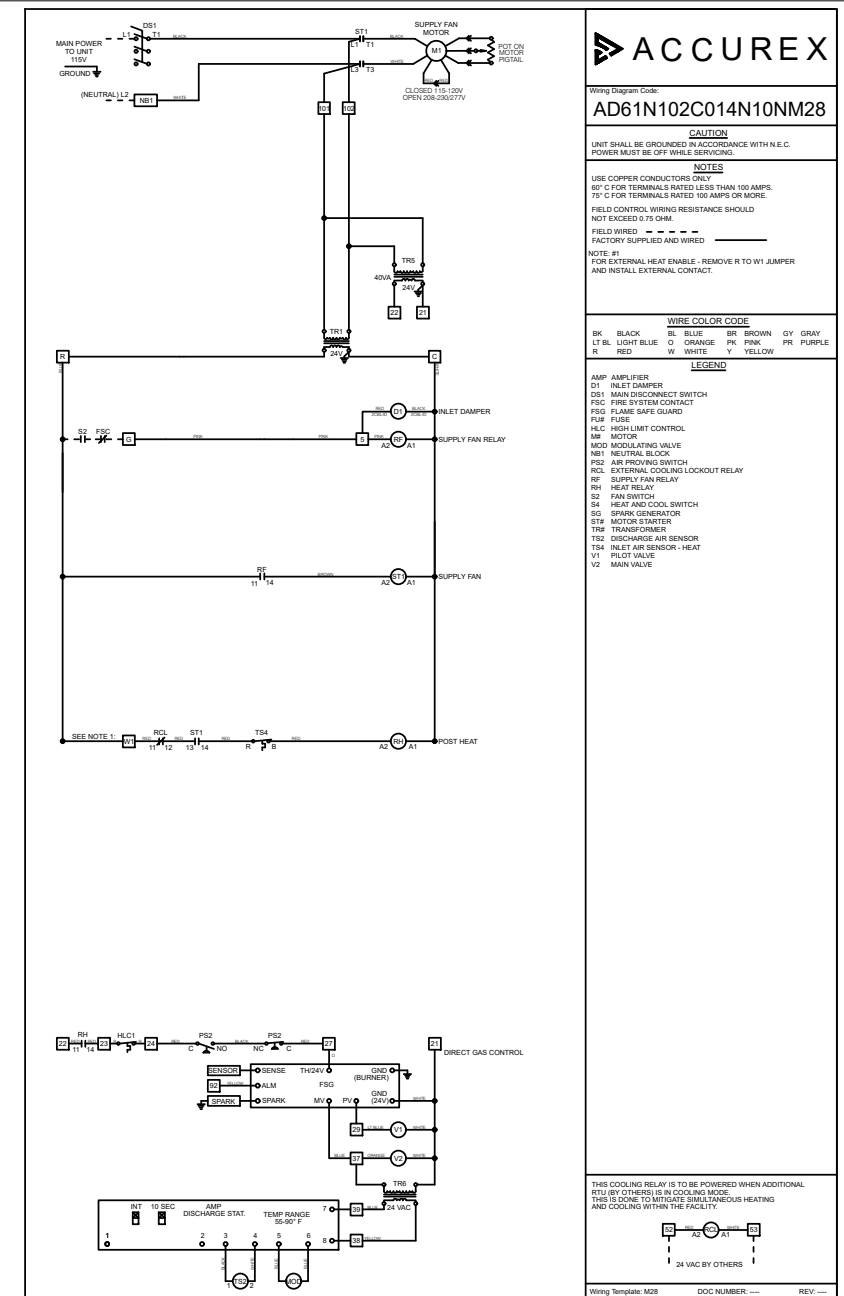

ACCUREX

Wiring Diagram Code:
AD61N102C014N10NM28

CAUTION
UNIT SHALL BE GROUNDED IN ACCORDANCE WITH N.E.C. POWER MUST BE OFF WHILE SERVICING.

NOTES
USE COPPER CONDUCTORS ONLY
60° C FOR TERMINALS RATED LESS THAN 100 AMPS.
75° C FOR TERMINALS RATED 100 AMPS OR MORE.
FIELD CONTROL WIRING RESISTANCE SHOULD NOT EXCEED 0.75 OHM.
FIELD WIRING: ————
FACTORY SUPPLIED AND WIRED: ————

NOTE #1
FOR EXTERNAL HEAT ENABLE, REMOVE R TO W1 JUMPER AND INSTALL EXTERNAL CONTACT.

WIRE COLOR CODE
BK BLACK BL BLUE BR BROWN GY GRAY
LT LIGHT BLUE O ORANGE PK PINK PR PURPLE
R RED W WHITE Y YELLOW

LEGEND
AMP AMPLIFIER
D1 INLET DAMPER
D2 MAIN DISCONNECT SWITCH
FSC FIRE SYSTEM CONTACT
FSG FLAME SAFE GUARD
FLS FUSE
HLC HIGH LIMIT CONTROL
IM MOTOR
MCV MODULATING VALVE
NBT NEUTRAL BLOCK
P2 AIR PROVING SWITCH
P3 AIR PROVING SWITCH
RCL EXTERNAL COOLING LOCKOUT RELAY
SF SUPPLY FAN RELAY
RH HEAT RELAY
S2 FAN SWITCH
S4 HEAT AND COOL SWITCH
SG SPARK GENERATOR
STB MOTOR STARTER
TR TRANSFORMER
TS2 DISCHARGE AIR SENSOR
T2B INLET AIR SENSOR - HEAT
V1 PILOT VALVE
V2 MAIN VALVE

THE COOLING RELAY IS TO BE POWERED WHEN ADDITIONAL RTUs BY OTHERS IS IN COOLING MODE. THIS IS DONE TO MITIGATE SIMULTANEOUS HEATING AND COOLING WITHIN THE FACILITY.

Wiring Diagram: M2B DOC NUMBER: REV: —

PROJECT: 12/2/2024
MARK: MAU-1
CHIPOTLE-JOSEY PARKER 5277

DIRECT CHAIN ACX
JOE AYUB
JOE.AYUB@ACCUREX.COM
(857)272-8727

ACCUREX

HVAC PLAN NOTES

- SEE ARCHITECTURAL REFLECTED CEILING PLAN FOR CEILING MOUNTED EQUIPMENT LOCATION. TYPICAL.
- PAINT DUCTWORK VISIBLE THROUGH DINING ROOM SUPPLY REGISTERS BLACK. TYPICAL.
- PENETRATIONS THROUGH SHEAR WALL SHALL BE LIMITED TO 10" DIAMETER (OR A GROUP OF PENETRATIONS ALL CONTAINED WITHIN 10" DIAMETER). IF LARGER PENETRATIONS OR GROUPS OF PENETRATIONS ARE REQUIRED COORDINATE WITH STRUCTURAL ENGINEER FOR APPROPRIATE BRACING. SEE STRUCTURAL DRAWINGS FOR SHEAR WALL LOCATION.
- 26/18 DUCT UP FOR TRANSITION TO RTU-1 RETURN CONNECTION IN ROOF CURB. RTU-1 SHALL HAVE AN INTEGRAL SMOKE DETECTOR MOUNTED IN THE RETURN AIR STREAM. INTERLOCK SMOKE DETECTOR TO RTU-1 OPERATION.
- 26/18 DUCT UP FOR TRANSITION TO RTU-2 RETURN CONNECTION IN ROOF CURB. RTU-2 SHALL HAVE AN INTEGRAL SMOKE DETECTOR MOUNTED IN THE RETURN AIR STREAM. INTERLOCK SMOKE DETECTOR TO RTU-2 OPERATION.
- 26/18 DUCT UP FROM BUILDING SUPPLY THROUGH ROOF. TRANSITION TO RTU-1 SUPPLY CONNECTION IN ROOF CURB.
- 26/18 DUCT UP FROM BUILDING SUPPLY TO RTU-2 SUPPLY CONNECTION. TRANSITION IN ROOF CURB.
- 16/16 DUCT UP THROUGH ROOF. TRANSITION TO MAU-1 SUPPLY CONNECTION IN ROOF CURB.
- 24/10 DUCT UP FROM HOOD THROUGH ROOF TO EF-1 COMPLIANT WITH NFPA 96. PROVIDE RADIUS ELBOWS WITH AN INSIDE RADIUS OF 0.5W AT ELBOWS IN GREASE DUCT.
- 8/6 DUCT UP THROUGH ROOF TO EF-2.
- 280/10 DUCT DOWN TO MAKEUP AIR PSP DUCT CONNECTION. TRANSITION TO SUPPLY PLENUM OPENING SIZE. TYPICAL. CAP UNUSED DUCT CONNECTIONS.
- 8" DIA. DUCT DOWN TO AC PSP DUCT CONNECTION. TRANSITION TO SUPPLY PLENUM OPENING SIZE. TYPICAL. CAP UNUSED DUCT CONNECTIONS.
- INSTALL GRIDPOINT THERMOSTATS FURNISHED BY TEMS FOR RTU-1 (TS200) AND RTU-2 (TS200) AT THIS LOCATION AT 48" AFF. COORDINATE WITH ELECTRICAL SWITCHING IN THIS AREA. PROVIDE THERMOSTAT WIRING FROM EACH THERMOSTAT TO THE CORRESPONDING ROOFTOP UNIT. PROVIDE CATSE CABLE FROM RTU-1 TS200 TO J-BOX #2 ABOVE ELECTRICAL PANELS (LEAVE 16" OF CABLE COILED UP INSIDE OF J-BOX #2 ND 16" BEHIND WALL OF THERMOSTAT FOR FINAL CONNECTION TO THE EMS SYSTEM BY THE TEMS) AND LABEL BOTH ENDS OF CABLE "TSTATS". SEE GRIDPOINT INSTALLATION INSTRUCTIONS FOR TERMINATION INSTRUCTIONS.
- INSTALL GRIDPOINT ZONE SENSOR MODULE FURNISHED BY TEMS FOR RTU-1 AT THIS LOCATION 84" AFF DIRECTLY TO WALL (NO JUNCTION BOX). COORDINATE LOCATION WITH EQUIPMENT. PROVIDE 18G-24G SHIELDED TWISTED PAIR FROM ZSM TO RTU-1 THERMOSTAT T1 TERMINALS. SEE GRIDPOINT INSTALLATION INSTRUCTIONS FOR TERMINATION INSTRUCTIONS.
- INSTALL GRIDPOINT ZONE SENSOR MODULE FURNISHED BY TEMS FOR RTU-2 AT THIS LOCATION 60" AFF DIRECTLY TO WALL (NO JUNCTION BOX). COORDINATE LOCATION WITH EQUIPMENT. PROVIDE 18G-24G SHIELDED TWISTED PAIR FROM ZSM TO RTU-2 THERMOSTAT T1 TERMINALS. SEE GRIDPOINT INSTALLATION INSTRUCTIONS FOR TERMINATION INSTRUCTIONS.
- INSTALL GRIDPOINT SUPPLY PROBE FURNISHED BY TEMS FOR RTU-1 IN THE SUPPLY DUCTWORK UPSTREAM FROM THE FIRST BRANCH CONNECTION. PROVIDE 18G-24G SHIELDED TWISTED PAIR FROM SUPPLY PROBE TO RTU-1 THERMOSTAT T2 TERMINALS. SEE GRIDPOINT INSTALLATION INSTRUCTIONS FOR TERMINATION INSTRUCTIONS.
- INSTALL GRIDPOINT SUPPLY PROBE FURNISHED BY TEMS FOR RTU-2 IN THE SUPPLY DUCTWORK UPSTREAM FROM THE FIRST BRANCH CONNECTION. PROVIDE 18G-24G SHIELDED TWISTED PAIR FROM SUPPLY PROBE TO RTU-2 THERMOSTAT T2 TERMINALS. SEE GRIDPOINT INSTALLATION INSTRUCTIONS FOR TERMINATION INSTRUCTIONS.
- INSTALL REMOTE TEMPERATURE SENSOR FOR HOOD HD-1 AT THIS LOCATION 84" AFF. COORDINATE LOCATION WITH EQUIPMENT. PROVIDE (2) #18 G. THERMISTOR CABLE FROM TEMPERATURE SENSOR TO HOOD CONTROL PANEL.

HVAC PLAN NOTES

- INSTALL KITCHEN HOOD, HD-1. SUPPORT HOOD PER MANUFACTURER'S INSTALLATION INSTRUCTIONS AND AS DETAILED IN THE ARCHITECTURAL AND STRUCTURAL DRAWINGS. INSTALL HOOD ACCORDING TO THE REQUIREMENTS OF ITS LISTING, IN COMPLIANCE WITH NFPA 96, THE BUILDING CODE, AND AUTHORITIES HAVING JURISDICTION. HOOD SHALL HAVE AN INTEGRAL DUCT COLLAR TEMPERATURE SENSOR TO AUTOMATICALLY ENERGIZE THE EXHAUST AND MAKEUP AIR FANS IF COOKING TEMPERATURES ARE DETECTED. EXHAUST DUCT SYSTEM TO BE WELDED OR FACTORY-MANUFACTURED WATER AND AIR TIGHT. INSTALL CLEANOUTS PER CODE AND AS SHOWN. INSTALL HOOD PER DETAILS 2 AND 4/M700. CHIPOTLE WILL PROVIDE AN INDEPENDENT TESTING AGENCY FOR TESTING THE INTEGRITY OF THE GREASE DUCT SYSTEM.
- INSTALL REMOTE CONDENSING UNIT FOR WALK-IN COOLER ON ROOF AS DETAILED IN THE ARCHITECTURAL AND STRUCTURAL DRAWINGS. CMG VENDOR TO INSTALL REFRIGERANT LINE SET, THERMOSTATIC EXPANSION VALVE, SOLENOID VALVE, TEMPERATURE CONTROL, SIGHT GLASS, FILTER DRIER, PRESSURE CONTROL, LOW AMBIENT CONTROLS, AND WEATHERPROOF HOUSING. TRAP AND SLOPE REFRIGERANT LINES PER MANUFACTURER'S RECOMMENDATIONS. INSTALLATION SHALL COMPLY WITH ASHRAE/ANSI STANDARD 15. INSTALL THE REFRIGERANT LINE SET UNDER THE ROOF DECK TO WITHIN 3' OF THE CONDENSING UNIT. CUT 2-1/2" HOLE IN WALK-IN COOLER ROOF FOR REFRIGERANT LINE SET AND SEAL PER THE COOLER MANUFACTURER'S INSTALLATION INSTRUCTIONS AFTER LINE SET IS INSTALLED.
- INSTALL REMOTE CONDENSER FOR ICE MACHINE ON ROOF AS DETAILED IN THE ARCHITECTURAL AND STRUCTURAL DRAWINGS. CMG VENDOR TO INSTALL REFRIGERANT LINE SET, THERMOSTATIC EXPANSION VALVE, SOLENOID VALVE, TEMPERATURE CONTROL, SIGHT GLASS, FILTER DRIER, PRESSURE CONTROL, LOW AMBIENT CONTROLS, AND WEATHERPROOF HOUSING. TRAP AND SLOPE REFRIGERANT LINES PER MANUFACTURER'S RECOMMENDATIONS. SEAL PIPING PENETRATIONS THROUGH ROOF. INSTALLATION SHALL COMPLY WITH ASHRAE/ANSI STANDARD 15. INSTALL THE REFRIGERANT LINE SET UNDER THE ROOF DECK TO WITHIN 3' OF THE REMOTE CONDENSER. IF REFRIGERANT PIPING TO ICE MAKER IS EXPOSED TO PUBLIC VIEW CONCEAL WITHIN A STAINLESS STEEL SHROUD AS SHOWN IN THE ARCHITECTURAL DRAWINGS.
- INSTALL ROOFTOP EQUIPMENT PER MANUFACTURER'S INSTALLATION INSTRUCTIONS AND AS DETAILED IN THE ARCHITECTURAL AND STRUCTURAL DRAWINGS.
- INSTALL EXHAUST FAN EF-1 PER DETAIL 5/M700 AND AS DETAILED IN THE ARCHITECTURAL AND STRUCTURAL DRAWINGS. INSTALL GREASE VIROGUARD SYSTEM FURNISHED BY CHIPOTLE ON EXHAUST FAN, EF-1.
- PROVIDE SUPPLY DIFFUSER CONNECTION TO SUPPLY SYSTEM PER DETAIL 1/M700. TYPICAL.
- PROVIDE AUDIO/VISUAL REMOTE SMOKE DETECTOR ANNUNCIATOR WITH REMOTE KEY OPERATED RESET. WIRE A UNIT BACK TO EACH SMOKE DETECTOR. MOUNT UNIT 60" AFF. TYPICAL.
- INSTALL REME HALO AIR PURIFIER FURNISHED BY TUV IN RTU PER DETAIL 6/M700. SEE ELECTRICAL DRAWINGS FOR POWER CONNECTION INFORMATION. INSTALL UV WARNING STICKERS ON FACE OF ENCLOSURE PER DETAIL AND ON ANY RTU ACCESS DOOR(S) THROUGH WHICH THE REME HALO WOULD BE VISIBLE IF OPENED.
- MAINTAIN 10' CLEARANCE BETWEEN WATER HEATER FLUE TERMINATION AND OUTSIDE AIR INTAKES. MAINTAIN 10' CLEARANCE BETWEEN WATER HEATER COMBUSTION AIR INTAKE AND EXHAUST FAN EF-1 DISCHARGE. SEE PLUMBING DRAWINGS FOR MORE INFORMATION ON WATER HEATER FLUE AND COMBUSTION AIR TERMINATIONS.
- ADJUST SUPPLY REGISTERS SO THAT SUPPLY AIR HITS WALL ON OPPOSITE SIDE OF ROOM AT APPROXIMATELY 20' FROM WALL. SEE PLUMBING DRAWINGS FOR MORE INFORMATION.
- PROVIDE AIR CURTAIN ABOVE DOOR. SEE MANUFACTURER'S SPEC SHEET.

6 M100
1/4" = 1'-0"

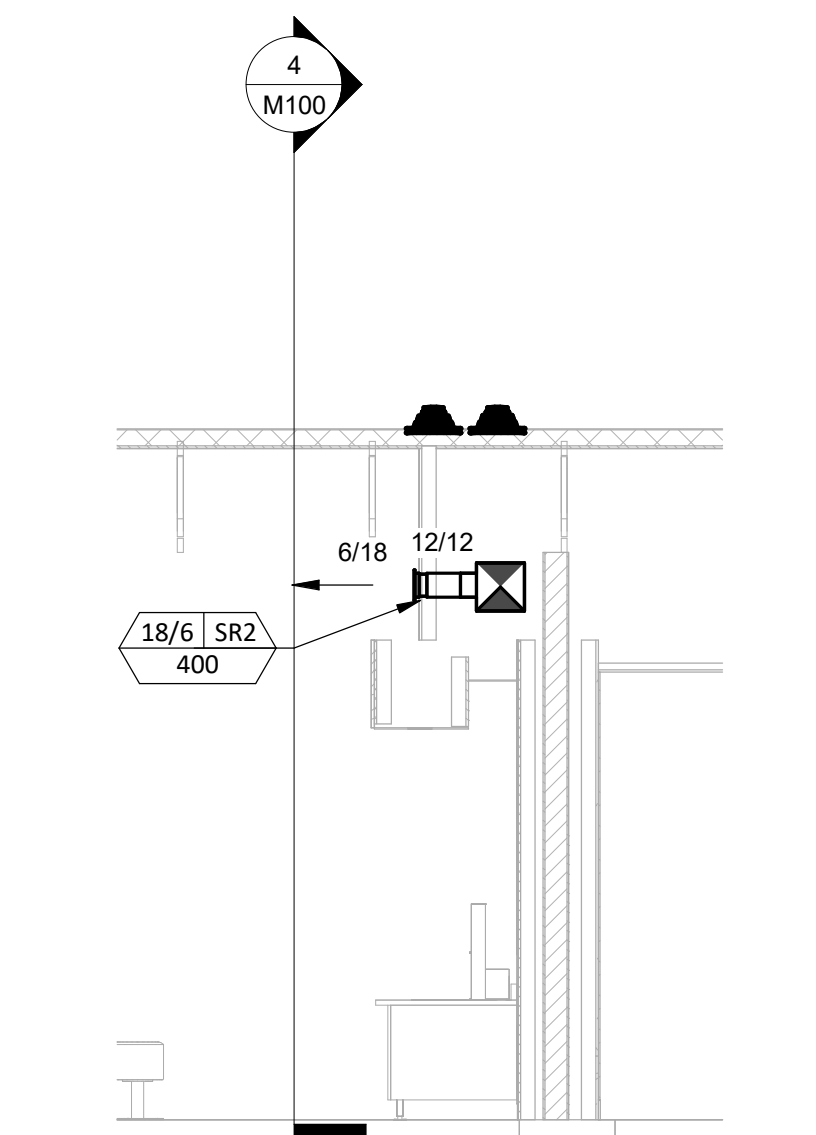
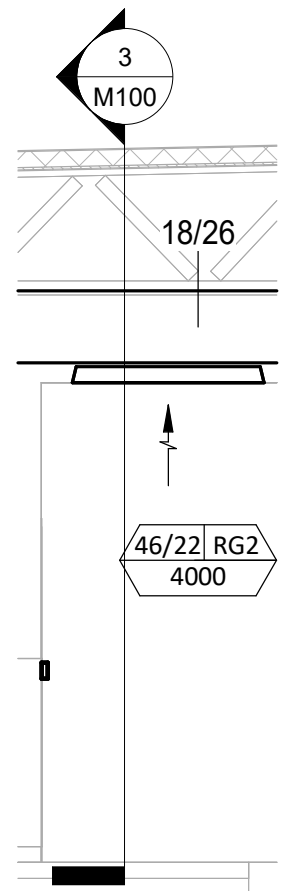

5 M100
1/4" = 1'-0"

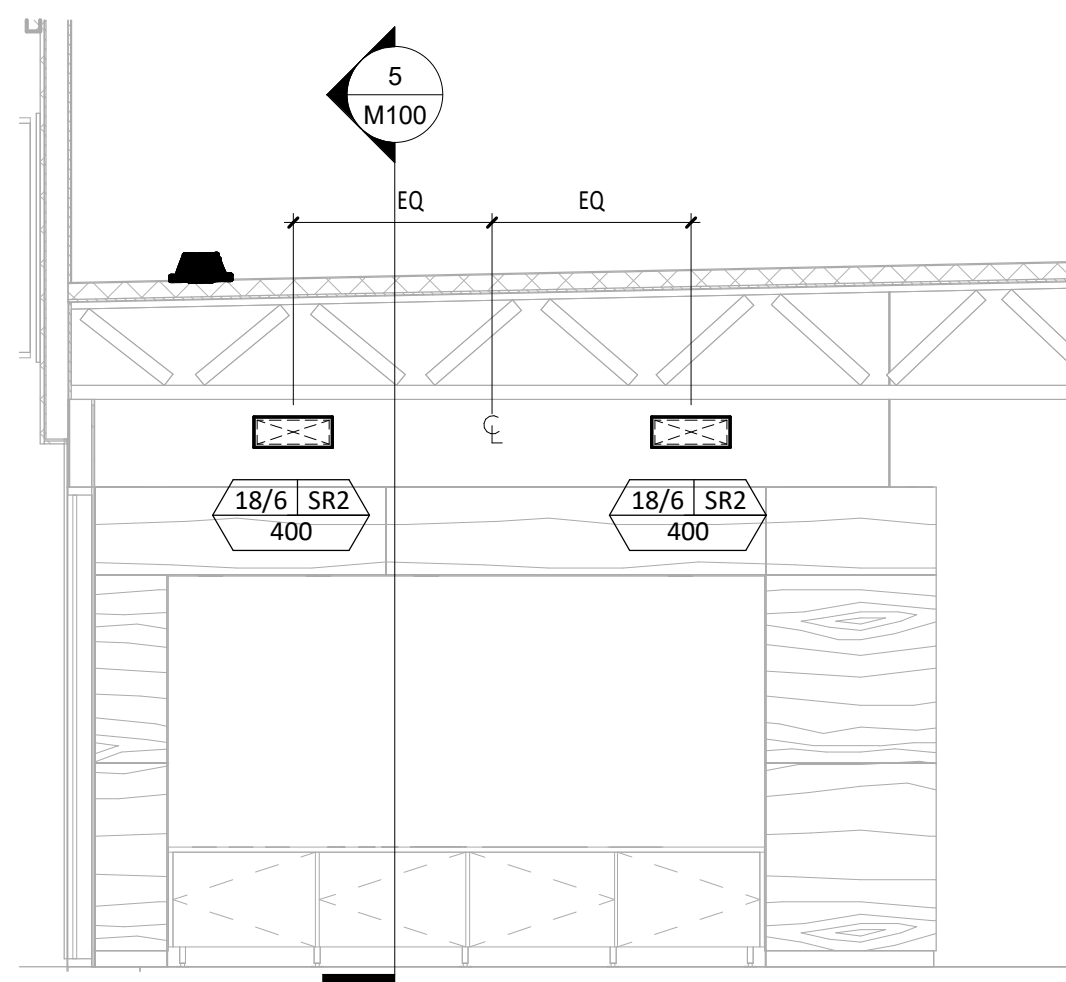

4 M100
1/4" = 1'-0"

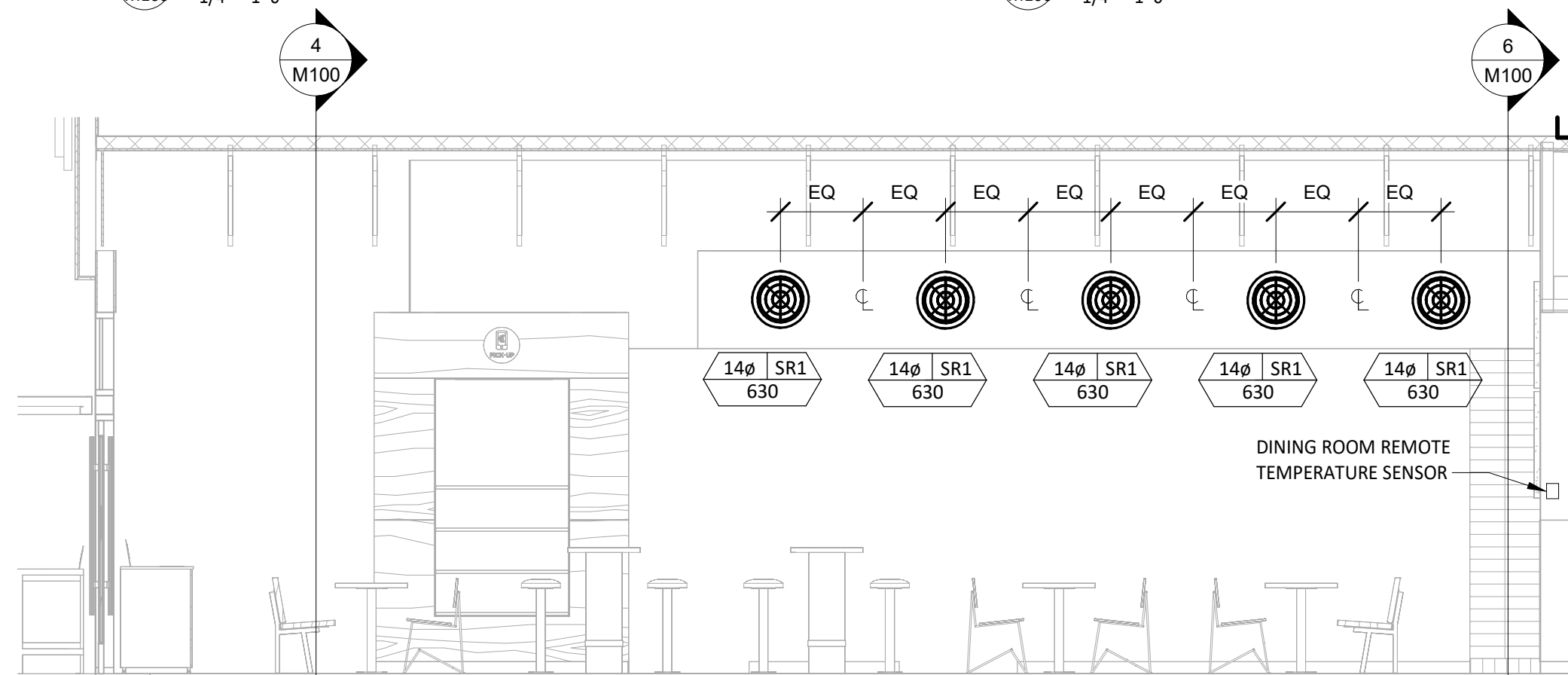

3 M100
1/4" = 1'-0"

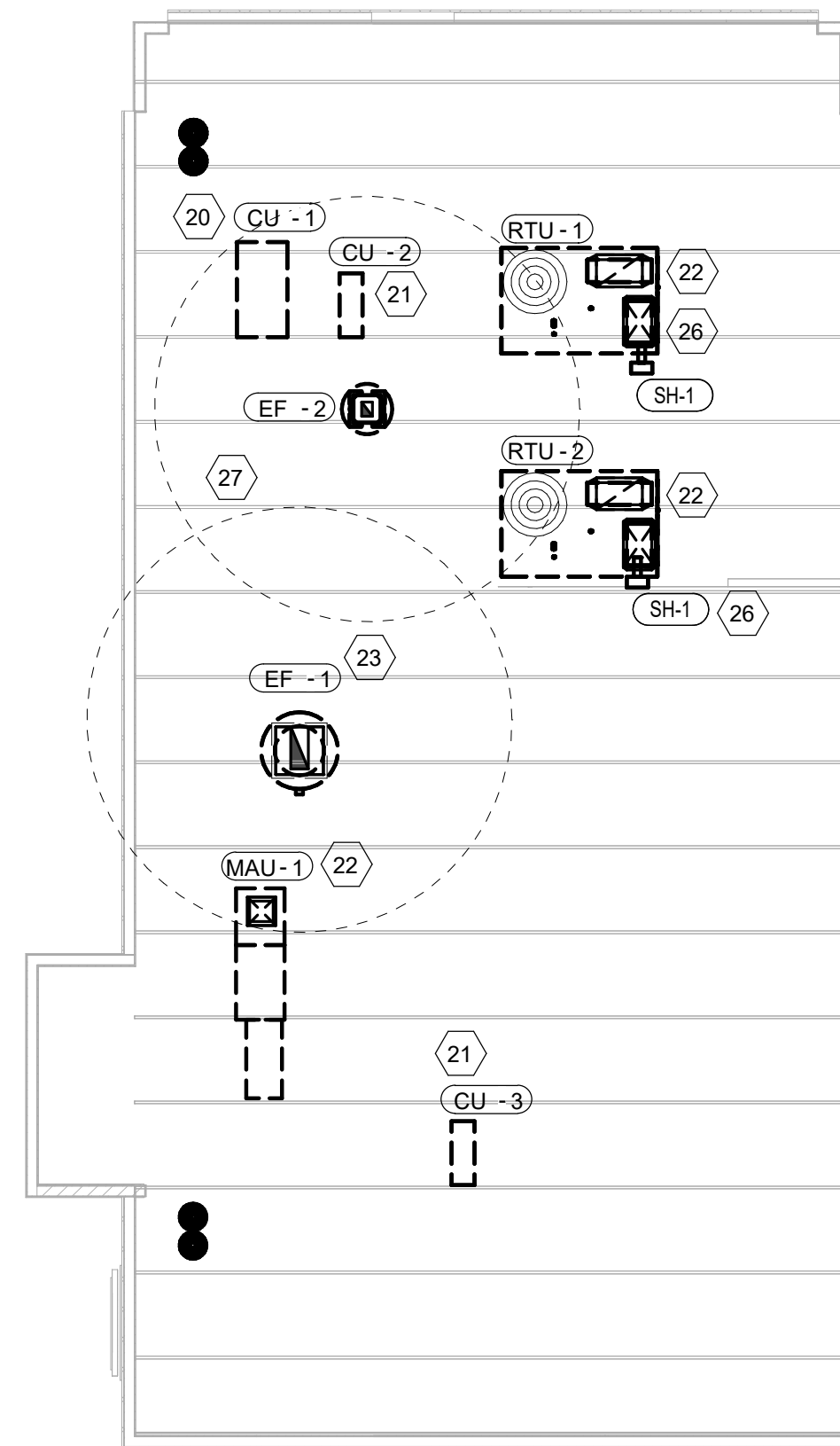

2 M100
1/8" = 1'-0"

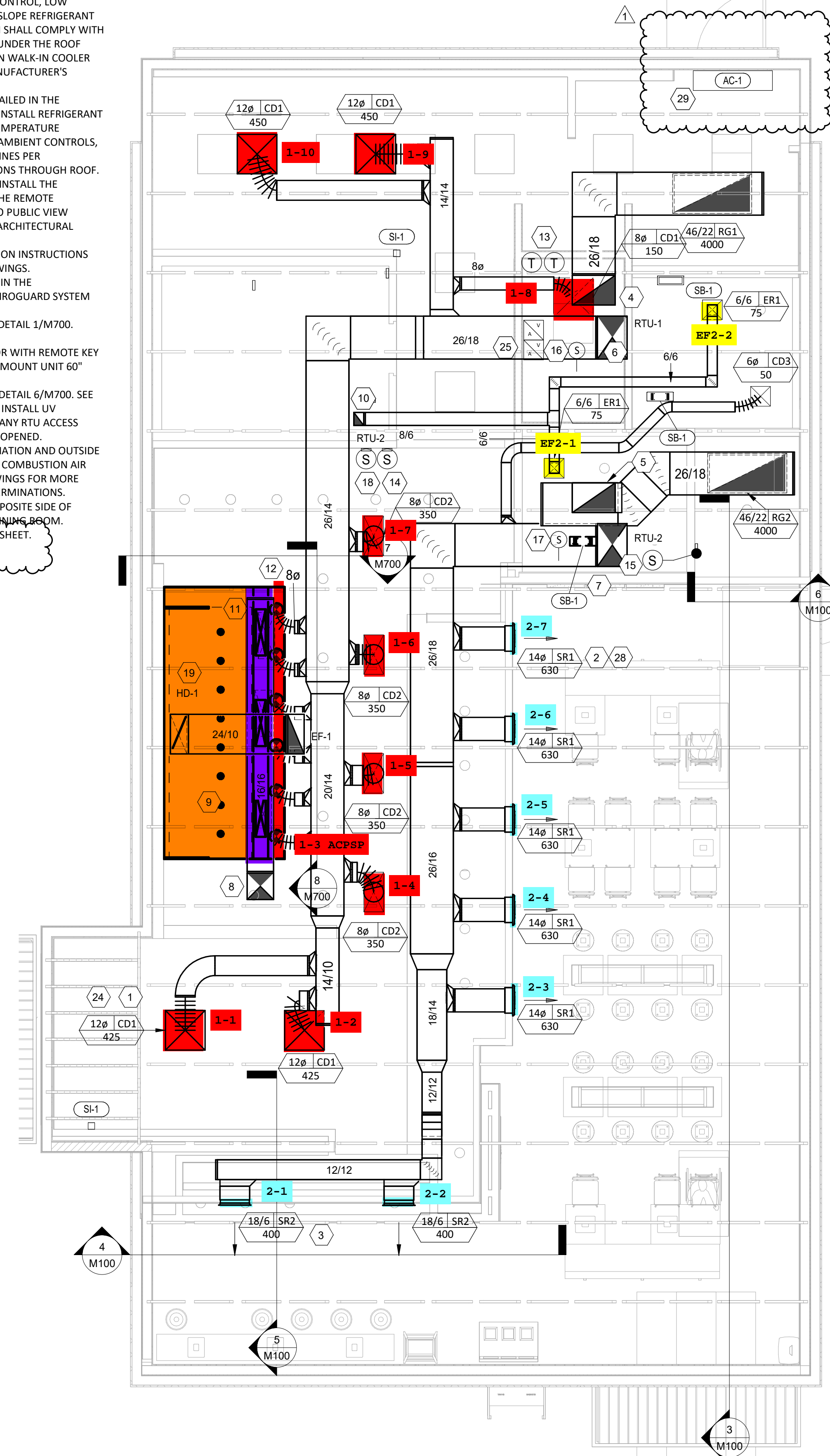

1 M100
1/4" = 1'-0"

ARCHITECT OF RECORD



513 MAIN STREET, SUITE 300
FORT WORTH, TEXAS 76102
(817) 820-0433

SEAL



CONSTRUCTION SET -
01/10/25

COPYRIGHT 2019
THIS DRAWING IS AN INSTRUMENT OF SERVICE
AND AS SUCH REMAINS THE PROPERTY OF
CHIPOTLE MEXICAN GRILL, INC. PERMISSION FOR
USE OF THIS DOCUMENT IS LIMITED AND CAN BE
EXTENDED ONLY BY WRITTEN AGREEMENT WITH
CHIPOTLE MEXICAN GRILL, INC.



CHIPOTLE MEXICAN GRILL, INC.
PO BOX 182566
COLUMBUS, OH 43218-2566
TELEPHONE: 614.318.2400
INTERNET: WWW.CHIPOTLE.COM

STORE NO.: 5277
JOSEY & PARKER
4825 N. JOSEY LN.
CARROLLTON, TX 75010

Issue Record:
11/25/24 PERMIT SET

Revisions:
1 12/12/24 CITY COMMENTS

Drawn: JW
Checked: JV

Project No:
24-0204

Contents:
HVAC PLAN

CASE
Engineering Inc.

M100



513 MAIN STREET, SUITE 300
FORT WORTH, TEXAS 76102
(817) 820-0433

SEAL



CONSTRUCTION SET -
01/10/25

COPYRIGHT 2019
THIS DRAWING IS AN INSTRUMENT OF SERVICE
AND AS SUCH REMAINS THE PROPERTY OF
CHIPOTLE MEXICAN GRILL, INC. PERMISSION FOR
USE OF THIS DOCUMENT IS LIMITED AND CAN BE
EXTENDED ONLY BY WRITTEN AGREEMENT WITH
CHIPOTLE MEXICAN GRILL, INC.



CHIPOTLE MEXICAN GRILL, INC.
PO BOX 182566
COLUMBUS, OH 43218-2566
TELEPHONE: 614.318.2400
INTERNET: WWW.CHIPOTLE.COM

STORE NO.: 5277
JOSEY & PARKER
4825 N. JOSEY LN.
CARROLLTON, TX 75010

Issue Record:
11/25/24 PERMIT SET

Revisions:
1 12/12/24 CITY COMMENTS

Drawn: JW Checked: JW

Project No:
24-0204

Contents:

MECHANICAL
SCHEDULES

M600



AIR BALANCE SCHEDULE

TAG	SUPPLY FLOW	RETURN FLOW	EXHAUST FLOW	SUBTOTAL
EF-1	0 CFM	0 CFM	2,550 CFM	-2,550 CFM
EF-2	0 CFM	0 CFM	150 CFM	-150 CFM
MAU-1	1,300 CFM	0 CFM	0 CFM	1,300 CFM
RTU-1	4,000 CFM	3,500 CFM	0 CFM	500 CFM
RTU-2	4,000 CFM	3,000 CFM	0 CFM	1,000 CFM
NET PRESSURIZATION				100 CFM

CONTROL FUNCTIONS

- THE MAIN COOKING EXHAUST FAN AND MAKE-UP AIR UNIT SHALL BE INTERLOCKED TO OPERATE TOGETHER. THIS CONTROL CIRCUIT IS ACTIVATED BY A SWITCH AND INCLUDES A FIRE PROTECTION OVERRIDE.
- THE TEMPERATURE IN EACH ZONE IS CONTROLLED BY SPACE TEMPERATURE SENSORS CONNECTED TO THE THERMOSTATS LOCATED IN THE OFFICE. ALL ZONES SHALL OPERATE WITH CONTINUOUS FAN OPERATION DURING OCCUPIED TIMES AND INTERMITTENTLY AS NEEDED TO MAINTAIN SET POINTS DURING UNOCCUPIED TIMES. OUTSIDE AIR DAMPERS SHALL BE OPEN CONTINUOUSLY WHEN EITHER IN OCCUPIED MODE OR WHEN THE HOOD SYSTEM IS ON AND SHALL BE CLOSED DURING UNOCCUPIED PERIODS.
- THE THERMOSTATS SHALL DETERMINE OCCUPIED/UNOCCUPIED STATUS BASED ON THE SCHEDULE IN THE ENERGY MANAGEMENT SYSTEM.

SANITIZING EQUIPMENT SCHEDULE

TAG	COUNT	DESCRIPTION	FURNISHED BY	INSTALLED BY	BASIS FOR DESIGN		REMARKS
					MANUFACTURER	MODEL	
SB-1	2	BATHROOM AIR PURIFICATION UNIT	TUV	GC	RGF ENVIRONMENTAL GROUP	BRU ASSEMBLY	SEE ELECTRICAL SHEETS FOR CONNECTION INFORMATION
SH-1	2	HVAC AIR PURIFICATION UNIT	TUV	GC	RGF ENVIRONMENTAL GROUP	REME-HALO	SEE DETAIL 6/M700 FOR INSTALLATION INFORMATION.
SI-1	3	ICE MACHINE TREATMENT SYSTEM	TUV	GC	RGF ENVIRONMENTAL GROUP	IMS-B-GA	SEE PLUMBING DRAWINGS FOR INSTALLATION INFORMATION.

FAN SCHEDULE

TAG	DESCRIPTION	AIRFLOW	E.S.P.	WEIGHT	ELECTRICAL		FURNISHED BY	INSTALLED BY	BASIS FOR DESIGN		REMARKS
					MOTOR POWER	V/P/H			MANUFACTURER	MODEL	
EF-1	UPBLAST DU180HFA EXHAUST FAN	2,550 CFM	1.45 in-wg	183 lb	2 hp	208/3/60	HS	GC	CAPTIVE-AIRE	DU180HFA	DIRECT DRIVE DU180HFA UPBLAST EXHAUST FAN FURNISHED WITH WEATHERPROOF DISCONNECT AND VENTED ROOF CURB
EF-2	DOWNBLAST RESTROOM EXHAUST FAN	150 CFM	0.60 in-wg	100 lb	0.18 hp	120/1/60	HS	GC	CAPTIVE-AIRE	DR12HFA	DIRECT DRIVE DOWNBLAST RESTROOM EXHAUST FAN FURNISHED WITH INTEGRAL DISCONNECT, SPEED CONTROL, BACKDRAFT DAMPER, AND CURB

VIROGUARD SCHEDULE

TAG	COUNT	DESCRIPTION	DUCT CONNECTION SIZE	FAN	FURNISHED BY	INSTALLED BY	BASIS FOR DESIGN MANUFACTURER
VG-1	1	VIROGUARD HOOD EXHAUST FAN ROOFTOP CONTAINMENT SYSTEM	16" X 16"	CAPTIVE-AIRE DU180HFA	TDC	GC	ENVIROMATIC

CONDENSING UNIT SCHEDULE

TAG	DESCRIPTION	NOMINAL CAPACITY	NUMBER OF		REFRIGERANT		WEIGHT	ELECTRICAL			FURNISHED BY	INSTALLED BY	BASIS FOR DESIGN		REMARKS
			COMPRESSORS	CIRCUITS	TYPE	CHARGE		MOC/P	FLA	V/P/H			MANUFACTURER	MODEL	
CU-1	CONDENSING UNIT - WALK-IN COOLER		1	1	R-404A	10.4 lb	250 lb	15 A	9 A	208/1/60	WCS	GC	RUSSELL DOE	RF0060M45DAALNT	FURNISHED WITH WALK-IN COOLER
CU-2	REMOTE CONDENSER - LOW CAPACITY ICE MAKER		0	1	R-404A	11.46 lb	100 lb			120/1/60	KES	GC	HOSHIZAKI	URC-9F	FURNISHED WITH ICE MAKER
CU-3	REMOTE CONDENSER - SODA MACHINE ICE MAKER		0	1	R-404A	3.86 lb	100 lb			120/1/60	KES	GC	HOSHIZAKI	URC-5F	FURNISHED WITH ICE MAKER

MAKEUP AIR UNIT SCHEDULE

TAG	DESCRIPTION	AIRFLOW	E.S.P.	HEATING			WEIGHT	ELECTRICAL		FURNISHED BY	INSTALLED BY	BASIS FOR DESIGN		REMARKS
				INPUT	OUTPUT	EAT		MOTOR POWER	V/P/H			MANUFACTURER	MODEL	
MAU-1	DIRECT-FIRED MAKEUP AIR UNIT	1,300 CFM	0.50 in-wg	70,942 Btu/h	65,267 Btu/h	21 °F	495 lb	2 hp	208/3/60	HS	GC	CAPTIVE-AIRE	A1-D.250-15D	12.5:1 MAX TURNDOWN. FURNISHED WITH DISCONNECT, ROOF CURB, SCREEN INTAKE, AND WASHABLE ALUMINUM FILTERS

AIR CURTAIN SCHEDULE	
DESIGNATION	AC-1
LENGTH	72"
MANUFACTURER	BERNER
MODEL	SLC07-1042A
VOLTAGE	120/1Ø
MCA/MOC/P	3.4/15
WEIGHT (LBS)	38
ACCESSORIES	PROVIDE ALL MANUFACTURER-RECOMMENDED ACCESSORIES FOR A COMPLETE OPERATIONAL SYSTEM. VERIFY EXACT SPECIFICATION WITH OWNER PRIOR TO ORDERING.

KITCHEN HOOD SCHEDULE

TAG	DESCRIPTION	MAX COOKING TEMP.	EXHAUST PLENUM							PERFORATED SUPPLY PLENUMS							BASIS FOR DESIGN		REMARKS						
			AIRFLOW	E.S.P.	DUCT COLLARS		LENGTH	WIDTH	LENGTH	WIDTH	MAU PLENUM			AC PLENUM		NO. OF LIGHT FIXTURES	WEIGHT	FURNISHED BY		INSTALLED BY	MANUFACTURER	MODEL			
					NO.	WIDTH					AIRFLOW	NO.	WIDTH	LENGTH	AIRFLOW								NO.	DIAMETER	
HD-1	TYPE I CANOPY HOOD WITH PERFORATED MAU AND AC SUPPLY PLENUMS	600 °F	2,550 CFM	0.96 in-wg	1	10"	24"	13'-9"	4'-3"	54"	19"	1,300 CFM	3	6"	2'-4"	696 CFM	8	8"	8	1,029 lb	HS	GC	CAPTIVE-AIRE	S424 ND-2-ACPS-P	MAT'L: 18 GA. TYPE 430 SS. FURNISHED WITH VERTICAL END PANELS, 24V GAS VALVE, VAPORPROOF INCANDESCENT LIGHT FIXTURES, 16" TALL HE SS FILTERS, INTEGRAL UTILITY CABINET, KITCHEN EXHAUST SUPPRESSION SYSTEM, DUCT COLLAR TEMPERATURE SENSOR, PREWIRE PACKAGE, SPARE FIRE SYSTEM DRY CONTACT, AND 4-POLE 20A CONTACTOR

ROOFTOP UNIT SCHEDULE

TAG	DESCRIPTION	NOMINAL CAPACITY	EER	AIRFLOW			NET COOLING CAPACITY				HEATING CAPACITY			NUMBER OF		REFRIGERANT	WEIGHT	ELECTRICAL			FURNISHED BY	INSTALLED BY	BASIS FOR DESIGN		REMARKS		
				TOTAL	OA	E.S.P.	TOTAL	SENSIBLE	DB	WB	COND. EAT	INPUT	OUTPUT	EAT	COMPRESSORS			CIRCUITS	TYPE	MOC/P			FLA	V/P/H		MANUFACTURER	MODEL
				4,000 CFM <th>500 CFM <th>1.0 in-wg <th>118,000 Btu/h <th>91,000 Btu/h <th>80 °F <th>67 °F <th>80 °F <th>250,000 Btu/h <th>205,000 Btu/h <th>65 °F <th>2 <th>2 <th>R-454B <th>1,445 lb <th>80 A <th>66 A <th>208/3/60 <th>CMG <th>GC <th>CARRIER <th>48FEFN12 </th></th></th></th></th></th></th></th></th></th></th></th></th></th></th></th></th></th></th></th></th>	500 CFM <th>1.0 in-wg <th>118,000 Btu/h <th>91,000 Btu/h <th>80 °F <th>67 °F <th>80 °F <th>250,000 Btu/h <th>205,000 Btu/h <th>65 °F <th>2 <th>2 <th>R-454B <th>1,445 lb <th>80 A <th>66 A <th>208/3/60 <th>CMG <th>GC <th>CARRIER <th>48FEFN12 </th></th></th></th></th></th></th></th></th></th></th></th></th></th></th></th></th></th></th></th>	1.0 in-wg <th>118,000 Btu/h <th>91,000 Btu/h <th>80 °F <th>67 °F <th>80 °F <th>250,000 Btu/h <th>205,000 Btu/h <th>65 °F <th>2 <th>2 <th>R-454B <th>1,445 lb <th>80 A <th>66 A <th>208/3/60 <th>CMG <th>GC <th>CARRIER <th>48FEFN12 </th></th></th></th></th></th></th></th></th></th></th></th></th></th></th></th></th></th></th>	118,000 Btu/h <th>91,000 Btu/h <th>80 °F <th>67 °F <th>80 °F <th>250,000 Btu/h <th>205,000 Btu/h <th>65 °F <th>2 <th>2 <th>R-454B <th>1,445 lb <th>80 A <th>66 A <th>208/3/60 <th>CMG <th>GC <th>CARRIER <th>48FEFN12 </th></th></th></th></th></th></th></th></th></th></th></th></th></th></th></th></th></th>	91,000 Btu/h <th>80 °F <th>67 °F <th>80 °F <th>250,000 Btu/h <th>205,000 Btu/h <th>65 °F <th>2 <th>2 <th>R-454B <th>1,445 lb <th>80 A <th>66 A <th>208/3/60 <th>CMG <th>GC <th>CARRIER <th>48FEFN12 </th></th></th></th></th></th></th></th></th></th></th></th></th></th></th></th></th>	80 °F <th>67 °F <th>80 °F <th>250,000 Btu/h <th>205,000 Btu/h <th>65 °F <th>2 <th>2 <th>R-454B <th>1,445 lb <th>80 A <th>66 A <th>208/3/60 <th>CMG <th>GC <th>CARRIER <th>48FEFN12 </th></th></th></th></th></th></th></th></th></th></th></th></th></th></th></th>	67 °F <th>80 °F <th>250,000 Btu/h <th>205,000 Btu/h <th>65 °F <th>2 <th>2 <th>R-454B <th>1,445 lb <th>80 A <th>66 A <th>208/3/60 <th>CMG <th>GC <th>CARRIER <th>48FEFN12 </th></th></th></th></th></th></th></th></th></th></th></th></th></th></th>	80 °F <th>250,000 Btu/h <th>205,000 Btu/h <th>65 °F <th>2 <th>2 <th>R-454B <th>1,445 lb <th>80 A <th>66 A <th>208/3/60 <th>CMG <th>GC <th>CARRIER <th>48FEFN12 </th></th></th></th></th></th></th></th></th></th></th></th></th></th>	250,000 Btu/h <th>205,000 Btu/h <th>65 °F <th>2 <th>2 <th>R-454B <th>1,445 lb <th>80 A <th>66 A <th>208/3/60 <th>CMG <th>GC <th>CARRIER <th>48FEFN12 </th></th></th></th></th></th></th></th></th></th></th></th></th>	205,000 Btu/h <th>65 °F <th>2 <th>2 <th>R-454B <th>1,445 lb <th>80 A <th>66 A <th>208/3/60 <th>CMG <th>GC <th>CARRIER <th>48FEFN12 </th></th></th></th></th></th></th></th></th></th></th></th>	65 °F <th>2 <th>2 <th>R-454B <th>1,445 lb <th>80 A <th>66 A <th>208/3/60 <th>CMG <th>GC <th>CARRIER <th>48FEFN12 </th></th></th></th></th></th></th></th></th></th></th>	2 <th>2 <th>R-454B <th>1,445 lb <th>80 A <th>66 A <th>208/3/60 <th>CMG <th>GC <th>CARRIER <th>48FEFN12 </th></th></th></th></th></th></th></th></th></th>			2 <th>R-454B <th>1,445 lb <th>80 A <th>66 A <th>208/3/60 <th>CMG <th>GC <th>CARRIER <th>48FEFN12 </th></th></th></th></th></th></th></th></th>	R-454B <th>1,445 lb <th>80 A <th>66 A <th>208/3/60 <th>CMG <th>GC <th>CARRIER <th>48FEFN12 </th></th></th></th></th></th></th></th>	1,445 lb <th>80 A <th>66 A <th>208/3/60 <th>CMG <th>GC <th>CARRIER <th>48FEFN12 </th></th></th></th></th></th></th>			80 A <th>66 A <th>208/3/60 <th>CMG <th>GC <th>CARRIER <th>48FEFN12 </th></th></th></th></th></th>	66 A <th>208/3/60 <th>CMG <th>GC <th>CARRIER <th>48FEFN12 </th></th></th></th></th>		208/3/60 <th>CMG <th>GC <th>CARRIER <th>48FEFN12 </th></th></th></th>	CMG <th>GC <th>CARRIER <th>48FEFN12 </th></th></th>
RTU-1	KITCHEN ROOFTOP UNIT	10 ton	11.2	4,000 CFM	500 CFM	1.0 in-wg	118,000 Btu/h	91,000 Btu/h	80 °F	67 °F	80 °F	250,000 Btu/h	205,000 Btu/h	65 °F	2	2	R-454B	1,445 lb	80 A	66 A	208/3/60	CMG	GC	CARRIER	48FEFN12	FURNISHED WITH COMP. ENTHALPY ECON., BAROMETRIC RELIEF, RET. SMOKE DETECTOR W/ REMOTE KEYED ANNUNCIATOR/RESET, M.O.D., MERV-8 FILTERS, CURB, HAIL GUARD, TOOLLESS HINGED ACCESS PANELS, DISCONNECT, HOT GAS REHEAT & UNIT-MOUNTED CONVENIENCE RECEPTACLE	
RTU-2	DINING ROOM ROOFTOP UNIT	10 ton	11.2	4,000 CFM	1,000 CFM	1.0 in-wg	118,000 Btu/h	91,000 Btu/h	80 °F	67 °F	80 °F	250,000 Btu/h	205,000 Btu/h	65 °F	2	2	R-454B	1,445 lb	80 A	66 A	208/3/60	CMG	GC	CARRIER	48FEFN12	FURNISHED WITH COMP. ENTHALPY ECON., BAROMETRIC RELIEF, RET. SMOKE DETECTOR W/ REMOTE KEYED ANNUNCIATOR/RESET, M.O.D., MERV-8 FILTERS, CURB, HAIL GUARD, TOOLLESS HINGED ACCESS PANELS, DISCONNECT, HOT GAS REHEAT & UNIT-MOUNTED CONVENIENCE RECEPTACLE	

CONTROL INFORMATION

MARK	ELECTRICAL CONTROL PACKAGE		USER INTERFACE		FANS CONTROLLED											
	MODEL	LOCATION	TYPE	LOCATION	FAN #	TYPE	FAN	FAN MARK	ZONE	CFM	MOTOR HP	MOTOR VOLT	CYCLE	MOTOR PHASE	MOTOR STARTER IN PANEL	VFD IN PANEL
HOOD CONTROLS	XKC-CV-SB-11-1-1-0	RIGHT CABINET ON HOOD-1	FULL COLOR TOUCHSCREEN	CABINET - RIGHT CABINET ON HOOD-1	1	SUPPLY	S1	MAU-1	1	1300	1	115	60	1	NO	NO
					2	EXHAUST	E1	EF-1 (HOOD-1) SINGLE PHASE	1	2550	2	208	60	1	NO	NO

CONTROL FEATURES
 HOOD LIGHT CONTROL
 TEMP SENSORS (FACTORY INSTALLED) - QTY. 1
 DRY FIRE CONTACTS - QTY. 2
 LIGHTS OFF DURING FIRE
 EXHAUST MAX DURING FIRE
 SUPPLY OFF DURING FIRE
 BMS INTEGRATION - BACNET MSTP

SPECIAL DESIGN REQUESTS
 SDR #K2300291-1 - APPLIANCE CONTACTORS - 20A



DOC NUMBER: ---	REV: ---	THESE DRAWINGS SHALL NOT BE REMOVED FROM THIS EQUIPMENT. USE COPPER CONDUCTORS RATED TO 90°C UNLESS SPECIFIED. TORQUE CONTROL & GROUND BLOCKS TO 8 LBS. IN. TORQUE POWER LUGS/SCREWS TO COMPONENT RATINGS LISTED. TORQUE CONTROL BOARD SCREW TERMINALS TO 3.5 LBS. IN. FIELD CONTROL WIRING RESISTANCE SHOULD NOT EXCEED 0.75 OHM. SEE IOM FOR ADDITIONAL INFORMATION, OR CALL FACTORY AT 1-800-371-8858.	NE PAS RETIRER CES DESSINS DE CET EQUIPEMENT SAUF INDICATION CONTRAIRE. UTILISER DES CONDUCTEURS EN CUIVRE CLASSÉS 90 °C. SERRER LES BORNES EN COMMANDE ET DE MISE À LA TERRE À 8 LB-PO. SERRER LES COSSÉS/VIS D'ALIMENTATION AUX COUPLES INDICQUÉS POUR LE COMPOSANT. SERRER LES BORNES À VIS DE LA CARTE DE COMMANDE À 3.5 LB-PO. LA RÉSISTANCE DU CÂBLAGE DE COMMANDE LOCAL NE DOIT PAS DÉPASSER 0.75 OHM. POUR PLUS D'INFORMATION, CONSULTER LE MANUEL OU APPELER 1-800-371-8858.
CAUTION UNIT MUST BE GROUNDED IN ACCORDANCE WITH N.E.C. POWER MUST BE OFF WHILE SERVICING.	ATTENTION L'APPAREIL DOIT ÊTRE MIS À LA TERRE CONFORMÉMENT AU CODE C.E. L'ALIMENTATION DOIT ÊTRE COUPÉE DURANT L'ENTRETIEN.	WIRING DIAGRAM CODE: WDC# JOB NAME: CHIPOTLE-JOSEY & PARKER 5277	
COMMERCIAL APPLIANCE OUTLET CENTER ELECTRICAL RATINGS: 110-240V, 1PHASE, 50-60HZ, 15A BASE FILE #E200616, ML FILE #E313951		MODEL: XKC-CV-SB-11-1-1-0 SERIAL NUMBER: WDSN# MARK: HOOD CONTROLS	

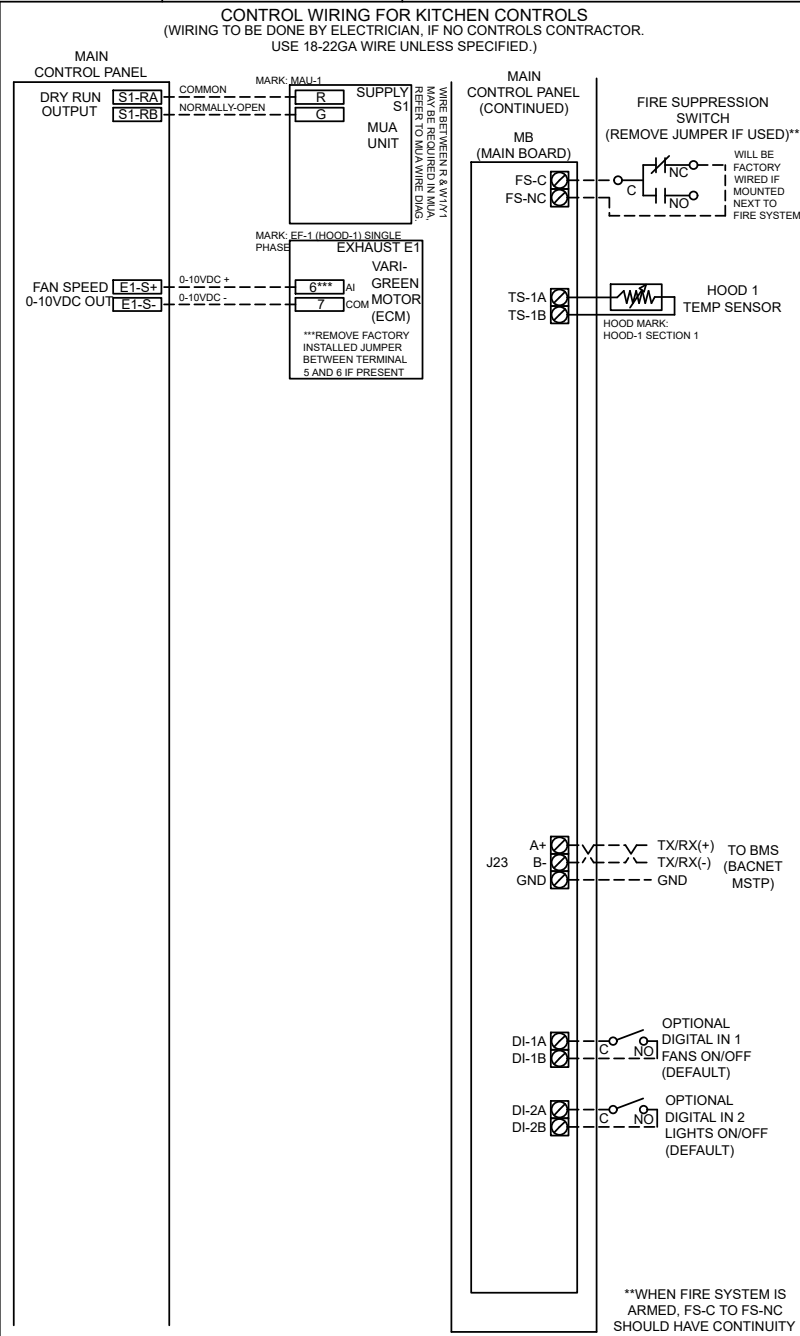
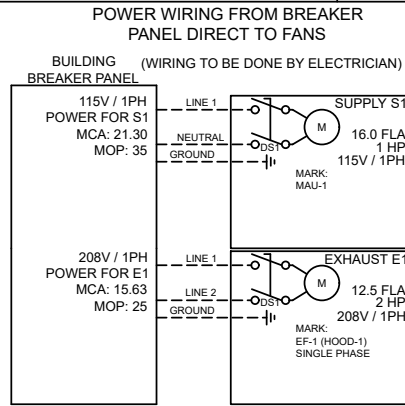
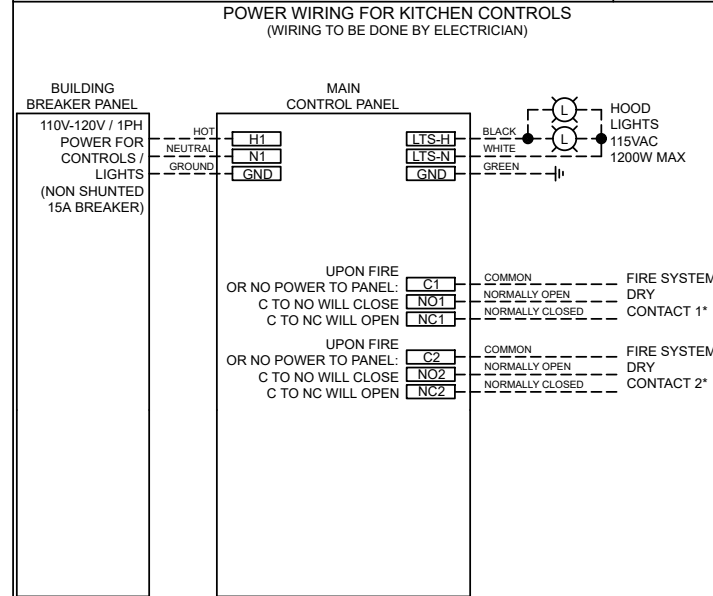

CABINET DETAILS	USER INTERFACE DETAILS
<p>DRAWING NOT TO SCALE</p> <p>KITCHEN HOOD</p> <p>CONTROLS</p>	<p>MOUNTING TYPE FACTORY MOUNTED: UTILITY CABINET - RIGHT END OF HOOD</p> <p>USER INTERFACE CONTROL FANS AND LIGHTS</p> <p>INTERFACE CABLE LENGTH 7FT (FACTORY PROVIDED)</p> <p>MOUNTING LOCATION: UTILITY CABINET ON HOOD (INNER CONTROL BOX: 12 X 20 X 6)</p> <p>NOTES: 1) WHEN CONTROLS ARE MOUNTED IN HOOD-MOUNTED OR WALL-MOUNTED UTILITY CABINET, FOR HOOD OR WALL CABINET DIMENSIONS SEE HOOD SUBMITTAL. 2) MINIMUM OF 36" OF CLEARANCE RECOMMENDED IN FRONT OF CONTROL CABINET</p>

ZONE CONFIGURATION <table border="1"> <thead> <tr> <th>ZONE #</th> <th>ZONE</th> <th>ROOM TEMP</th> </tr> </thead> <tbody> <tr> <td>1</td> <td>Z1</td> <td>PRESET</td> </tr> </tbody> </table>			ZONE #	ZONE	ROOM TEMP	1	Z1	PRESET	WIRING DIAGRAM CODE: WDC# JOB NAME: CHIPOTLE-JOSEY & PARKER 5277 MODEL: XKC-CV-SB-11-1-1-0 SERIAL NUMBER: WDSN# MARK: HOOD CONTROLS DOC NUMBER: --- REV: ---																																			
ZONE #	ZONE	ROOM TEMP																																										
1	Z1	PRESET																																										
HOOD CONFIGURATION <table border="1"> <thead> <tr> <th>HOOD #</th> <th>HOOD</th> <th>HOOD MARK</th> <th>ZONE</th> <th>EXHAUST</th> <th>SUPPLY</th> <th>MB-TEMP SENSORS</th> <th>HCB</th> </tr> </thead> <tbody> <tr> <td>1</td> <td>H1</td> <td>HOOD-1 SECTION 1</td> <td>Z1</td> <td>E1</td> <td>S1</td> <td>TS1</td> <td>NO</td> </tr> </tbody> </table>			HOOD #	HOOD	HOOD MARK	ZONE	EXHAUST	SUPPLY	MB-TEMP SENSORS	HCB	1	H1	HOOD-1 SECTION 1	Z1	E1	S1	TS1	NO	DEFAULT SETTINGS / PARAMÈTRES PAR DÉFAUT TYPE: CV CONFIGURATION: STANDARD ZONES: 1 HOODS: 1 SUMPS: 0 EXHAUST FANS: 1 SUPPLY FANS: 1 MB ROOM SENSOR: NO MB TEMP SENSORS: 1 HIGH TEMP FAULT: NO FREEZE PROTECTION: YES GAS RESET: NO FAN PROVING: NO BMS: BACNET MSTP																									
HOOD #	HOOD	HOOD MARK	ZONE	EXHAUST	SUPPLY	MB-TEMP SENSORS	HCB																																					
1	H1	HOOD-1 SECTION 1	Z1	E1	S1	TS1	NO																																					
FAN CONFIGURATION <table border="1"> <thead> <tr> <th>FAN #</th> <th>TYPE</th> <th>FAN</th> <th>FAN MARK</th> <th>ZONE</th> <th>MIN CFM</th> <th>MAX CFM</th> <th>MODBUS VFD</th> <th>VFD ADDRESS</th> <th>MIN FREQ.</th> <th>MAX FREQ.</th> <th>MIN VDC</th> <th>MAX VDC</th> </tr> </thead> <tbody> <tr> <td>1</td> <td>SUPPLY</td> <td>S1</td> <td>MAU-1</td> <td>Z1</td> <td>-</td> <td>1300</td> <td>NO</td> <td>-</td> <td>-</td> <td>-</td> <td>-</td> <td>10.0</td> </tr> <tr> <td>2</td> <td>EXHAUST</td> <td>E1</td> <td>EF-1 (HOOD-1) SINGLE PHASE</td> <td>Z1</td> <td>-</td> <td>2550</td> <td>NO</td> <td>-</td> <td>-</td> <td>-</td> <td>-</td> <td>7.7</td> </tr> </tbody> </table>			FAN #	TYPE	FAN	FAN MARK	ZONE	MIN CFM	MAX CFM	MODBUS VFD	VFD ADDRESS	MIN FREQ.	MAX FREQ.	MIN VDC	MAX VDC	1	SUPPLY	S1	MAU-1	Z1	-	1300	NO	-	-	-	-	10.0	2	EXHAUST	E1	EF-1 (HOOD-1) SINGLE PHASE	Z1	-	2550	NO	-	-	-	-	7.7	PRG VERSION: V4		
FAN #	TYPE	FAN	FAN MARK	ZONE	MIN CFM	MAX CFM	MODBUS VFD	VFD ADDRESS	MIN FREQ.	MAX FREQ.	MIN VDC	MAX VDC																																
1	SUPPLY	S1	MAU-1	Z1	-	1300	NO	-	-	-	-	10.0																																
2	EXHAUST	E1	EF-1 (HOOD-1) SINGLE PHASE	Z1	-	2550	NO	-	-	-	-	7.7																																

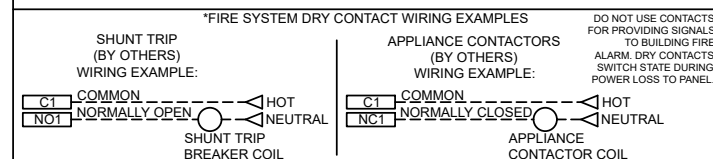

SERVICE INFORMATION

MARK: CERTIFICATION	MODEL: CERTIFICATION
ITEM: SERVICE	QUANTITY: 1

ACCUREX AFTERMARKET CERTIFICATION PROGRAM CONFIRMS THE EQUIPMENT IS INSTALLED AND OPERATING ACCORDING TO THE MANUFACTURER'S REQUIREMENTS BY A FACTORY AUTHORIZED SERVICER (FAS). INSTALLATION AND START-UP OF EQUIPMENT PER THE MANUFACTURER'S INSTALLATION AND OPERATIONS MANUAL TO BE PERFORMED BY OTHERS PRIOR TO THIS SERVICE. A WRITTEN REPORT WILL BE PROVIDED AFTER THIS SERVICE IS COMPLETED.

TRIP QUANTITY: 1

ONE TRIP TO THE JOBSITE INCLUDED FOR THE CERTIFICATION WORK TO BE PERFORMED (TIME ONSITE TBD BASED ON EQUIPMENT SELECTED)

EQUIPMENT INCLUDED IN CERTIFICATION:

- HOOD CONTROLS
- MAU-1
- EF-2 (RESTROOM)
- HOOD-1
- EF-1 (HOOD-1)

 ACCUREX	DIRECT CHAIN ACX JOE AYUB JOE.AYUB@ACCUREX.COM (857)272-8727
	PROJECT 12/27/2024
MARK CHIPOTLE-JOSEY PARKER 5277	CERTIFICATION
	

FIRE SYSTEM INFORMATION

MARK	MODEL	LOCATION	FLOW POINTS		SUPPLY LINE	DETECTION	MARK(S) PROTECTED BY FIRE SYSTEM
			HOODS	PCU			
FSS	ANSUL R-102 WET CHEMICAL	CABINET – RIGHT END OF HOOD-1	13 UTILIZED 22 AVAILABLE		CONTINUOUS	FUSIBLE LINK	HOOD-1 SECTION 1

FIRE SYSTEM OPTIONS AND ACCESSORIES

FULL INSTALLATION (INCLUDES PRE-PIPED HOOD(S) WITH DETECTION AND FACTORY COORDINATED INSTALL)
 CHROME SLEEVES FOR FACTORY PROVIDED APPLIANCES DROPS - INCLUDED
 METAL BLOW-OFF CAPS - INCLUDED
 GAS VALVE - INCLUDED - ELECTRICAL SHUTOFF VALVE, 1.5", 110V, 60HZ - PART# 455396
 HOOD SUPPRESSION TANK - INCLUDED - 6 GAL. - [(2) 3.0 TANK(S)]
 REMOTE PULL STATION - STANDARD - FIELD INSTALLATION AT SINGLE POINT OF EGRESS

ANSUL R102 (WET CHEMICAL) FIRE PROTECTION SYSTEM - MODEL FSSC

CONTROL PANEL

NOTES:

WET CHEMICAL FIRE PROTECTION SYSTEM TO BE ANSUL R-102, DESIGNED IN COMPLIANCE WITH UL 300 REQUIREMENTS.

- VERIFICATION OF ALL COOKING EQUIPMENT MAKE, MODEL AND LOCATION REQUIRED FOR ALL FIRE PROTECTION SYSTEMS.
- ALL FIRE SYSTEM PIPING IS STANDARDLY TO THE RIGHT END OF THE HOOD UNLESS A WALL IS LOCATED ON THE RIGHT END.
- ANSUL AUTOMAN RELEASE TO BE LOCATED WITHIN 60" OF HOOD.

THE BASIC FIRE SYSTEM WILL INCLUDE THE FOLLOWING:

- GAS SHUT-OFF VALVE, IF REQUIRED, TO BE SUPPLIED BY MANUFACTURER (UP TO 2" DIAMETER AS STANDARD), AND INSTALLED BY A LICENSED PLUMBER.
- MICRO SWITCH TO BE SUPPLIED BY MANUFACTURER FOR CONNECTION TO, BUT NOT LIMITED TO, BUILDING ALARM SYSTEM(S), EXHAUST AND SUPPLY FANS AND ELECTRICAL POWER SHUT DOWN. FIELD WIRING AND CONNECTIONS TO BE PERFORMED BY A LICENSED ELECTRICIAN.

THE BASIC FIRE SYSTEM DOES NOT INCLUDE THE FOLLOWING:

- FULL DUMP TEST OTHER THAN WHAT IS SPECIFIED PER THE INSTALLATION MANUAL, OR TO SATISFY A STATE OR LOCAL CODE. PERMIT AND TESTING FEES ARE NOT INCLUDED UNLESS NOTED UNDER THE EQUIPMENT SCHEDULE FOR THE FIRE SYSTEM.
- MORE THAN TWO TRIPS TO THE JOBSITE OR SPECIAL TRANSPORTATION, OR OVERNIGHT LODGING REQUIREMENTS IN REMOTE AREAS. NORMAL TRAVEL DISTANCE IS FIRST 50 MI. (80.5 KM) FROM OFFICE.
- SPECIAL CLASSES OR ADDITIONAL LABOR FOR ACCESS TO SECURITY SENSITIVE AREAS.
- INSTALLATION OF GAS SHUT-OFF VALVE.
- SPECIAL DRAWINGS REQUIRED TO SATISFY STATE OR LOCAL CODE. PLAN EXAMINATION FEES, PE OR P'S APPROVAL STAMP.
- UNION LABOR, GOVERNMENT LABOR, OR PREVAILING WAGES REQUIRED FOR FINAL FIELD HOOK-UP.
- ANY AND ALL ELECTRICAL COMPONENTS/CONNECTIONS REQUIRED TO SHUT DOWN FANS, SHUT OFF DEVICE FOR ELECTRIC COOKING EQUIPMENT (SHUNT TRIP BREAKER), OR ACTIVATE AN ALARM SYSTEM, ETC.
- ANY DISMANTLING OR REASSEMBLY REQUIRED TO GAIN ACCESS TO THE FIRE SUPPRESSION PIPING LOCATED ON THE TOP OF THE HOOD.
- ROUGH-IN HIDDEN CONDUIT FOR REMOTE PULL STATION OR GAS VALVE (FLUSH MOUNTED PULL STATION).
- INSTALLATION OF MORE THAN (1) REMOTE PULL STATIONS OR DISTANCES GREATER THAN 20 FT (6.1M).
- PARTS OR LABOR REQUIRED TO CORRECT PIPING DUE TO COOKING EQUIPMENT CHANGES OR DEVIATION FROM PLANS. OR ANY CHARGES FOR MISSING OR ADDITIONAL PARTS OTHER THAN THOSE INDICATED ON THE FIRE SUPPRESSION DETAIL.

WIRING DIAGRAM FOR MICRO SWITCHES

NOTES:

IF ELECTRIC RELEASE, BOTH UPPER SWITCHES WILL BE USED FOR ACTUATING ADDITIONAL AUTOMANS (THEY WILL BE WIRED TO EACH OTHER AND TO THE BROWN WIRE ON THE ELECTRIC SOLENOID). THEREFORE, USE ONE OF THE UN-UTILIZED LOWER SWITCHES TO WIRE BACK TO CONTROL PANEL (DO NOT USE EITHER OF THE UPPER SWITCHES).

IF USING LOWER SWITCHES TO WIRE BACK TO CONTROL PANEL, NORMALLY-CLOSED WILL BE BLACK LEAD, AND NORMALLY-OPEN WILL BE BROWN LEAD.

DPDT SWITCHES PROVIDED BY MANUFACTURER MAY BE WIRED PER TYPICAL EXAMPLES SHOWN. VERIFY WITH LOCAL CODES AND EQUIPMENT SUPPLIED AS THE CONNECTION NEEDED FOR YOUR INSTALLATION.

WIRING DIAGRAM FOR MANUAL RESET RELAY (ELECTRIC GAS VALVE ONLY)

NOTES:

1. --- DENOTES FIELD INSTALLATION.

2. ——— DENOTES FACTORY INSTALLATION.

PROJECT 12/2/2024

MARK

ANSUL R102 (WET CHEMICAL) FIRE PROTECTION SYSTEM - MODEL FSSC

UL LISTED

CONFORMS TO UL 300

CHIPOTLE-JOSEY & PARKER

5277

FSS

DIRECT CHAIN ACX

JOE AYOUB

JOE.AYOUB@ACCUREX.COM

(857)272-8727

ACCUREX