

PROJECT # 107237, AESC-SC1 – Florence, SC
1330 Estate Road
Florence, SC 29506

Date: 6/18/2024

Reference Number: 211

Transmitted To: Grant Parsons
I.C. Thomasson Associates, Inc.
2950 Kraft Drive
Nashville, TN 37204
Tel: 615-346-3400
Fax:

Transmitted By: Cesar Villagrana
SPC Mechanical Corporation
1500 Wendell Blvd.
Wendell, NC 27591
Tel:
Fax:

Submitting Company:

Submittal Package No	Description	Package Category
211 - 23 7313	Submittal 211 - RTS-01 thru RTS-06 AHU's (FOR RECORD)	CR M E P FP

Item #	Ref #	Rev	Description	Status	Due	Returned
1	000897	1	AIR HANDLING UNIT - MEDIUM OR LOW PRESSURE		3/21/2024	

Item Notes:

Package Notes:

- Submittal for record includes only Units RTS-1 to RTS-6 previously Approved.
- Roof curbs not included on this submittal.

-SPC Mechanical to furnish an install items according to Scope Work, Specs and Mechanical Schedules including those noted as "by others" by manufacturer.

C:

 THE ART & SCIENCE OF BUILDING	<input type="checkbox"/> Reviewed
	<input type="checkbox"/> Reviewed As Noted
	<input type="checkbox"/> Revise and Resubmit
This review is only for general conformance with the contract documents and is subject to final review by the Designer of Record. Corrections or Comments made on these documents during this review do not relieve subcontractor/vendor from compliance with the requirements of the plans and specifications. All dimensions, quantities, field measurements, and installation requirements remain the responsibility of the subcontractor /vendor.	
Submittal #	211
Spec Section	23 7313
Description	Submittal 211 - RTS-01 thru RTS-06 AHU's
Subcontractor	SPC Mechanical
Reviewer	Francisco Robledo
Date	06/20/2024

<input type="checkbox"/> APPROVED	<input type="checkbox"/> FURNISH AS CORRECTED
<input type="checkbox"/> REJECTED	<input type="checkbox"/> REVISE AND RESUBMIT
<input type="checkbox"/> SUBMIT SPECIFIED ITEM	<input checked="" type="checkbox"/> REVIEWED
This review is only for general conformance with the design concept and the information given in the Construction Documents. Contractor is responsible for compliance with the information provided in the contract documents. Corrections or comments made on the shop drawings during this review do not relieve the contractor from compliance with the requirements of the plans and specifications and applicable laws, codes and regulations. Review of a specific item shall not include review of an assembly of which the item is a component. The Contractor is responsible for: dimensions to be confirmed and correlated at the jobsite; information that pertains solely to the fabrication processes or to the means, methods, techniques, sequences and procedures of construction; coordination of the Work with that of all other trades and performing all Work in a safe and satisfactory manner.	
BY: Reagan McMann	
DATE: 06/28/2024	
 I. C. THOMASSON ASSOCIATES, INC.	



SPC Mechanical
 10125 Berkeley Pl Dr
 Charlotte, NC 28262

Submittal

WR2310-S019.1 Submittal

REVIEW DATE:

PROJECT NAME:

JOB NUMBER:

ARCHITECT:

ENGINEER:

PRODUCT/MATERIAL ID:

SPEC. SECTION/PARAGRAPH NO.:

SUBCONTRACTOR/SUPPLIER:

NOTES:

ARCHITECT/ENGINEER REVIEW/APPROVAL	SPC REVIEW/APPROVAL
	<input type="checkbox"/> No Exceptions Taken
	<input type="checkbox"/> Exceptions Indicated
	<input type="checkbox"/> Rejected - Revise & Resubmit
	<p>SPC'S REVIEW IS FOR CONFORMANCE WITH THE GENERAL DESIGN CONCEPT AND FOR GENERAL ARRANGEMENT ONLY.</p> <p>REVIEW SHALL NOT BE CONSTRUED TO MEAN THAT SPC ACCEPTS ANY DEVIATIONS FROM THE CONTRACT DOCUMENTS UNLESS NOTED AND APPROVED BY SPC AND BY THE ARCH/ENG.</p> <p>SUPPLIER IS RESPONSIBLE FOR ERRORS OR OMISSIONS IN THE SHOP DRAWINGS, FOR MEETING ALL REQUIREMENTS OF THE CONTRACT DOCUMENTS, FOR CONFIRMING AND CORRELATING JOBSITE DIMENSIONS, FOR INFORMATION THAT PERTAINS SOLELY TO FABRICATION PROCESSES OR TO TECHNIQUES OF CONSTRUCTION, AND FOR COORDINATION OF THE WORK, EQUIPMENT AND/OR SUPPLIES</p> <p>ALL MATERIAL MUST BE SHIPPED AS PER SPC PURCHASE ORDER</p>



EQUIPMENT SUBMITTAL FOR RECORD

PROJECT: AESC Battery Manufacturing Plant

LOCATION: Florence, SC



Note: Picture is example only – see submittal for drawings

EQUIPMENT	Semi-Custom Air Handling Units
UNIT TAGS	VARIOUS
QUANTITY	113
SPEC SECTION	23 7313

SOLD TO:
SPC Mechanical

CONSULTANT:
I.C.Thomasson Associates

PREPARED BY:
Johnson Controls, Inc.

DATE:
Jun 10, 2024

REVISION:
1

General Notes/Clarifications/CDE



General Notes

- Contractor/Engineer to confirm unit performance prior to release.
- Contractor to approve unit dimensions and handling for site coordination purposes.
- All power wiring to unit to be supplied and installed by others unless explicitly mentioned.
- Long term storage is required if unit is not started up within 6 months of shipment, or if equipment will be shipped over a body of salt water, or if equipment will be located within 5 miles of a body of salt water
- Any included startup/field work/training must be performed during normal working business hours 7am-3pm (Mon-Fri) and excluding any holidays. Start-up/field work/training requested outside of normal business hours are subject to a change order.
- Any quoted training are NOT videotaped unless explicitly mentioned.

Clarifications

- If Units are not Started Up within 6 months, additional cost increase will occur due to delayed Start-Up (Delayed Start-Up is not included; must be purchased separately if required)
- Any Accessories Not Specified in the Items Included will not be Provided
- Request for Items Not Listed and Not Included will be a Change Order
- Please see CDE section (starting next page).

SECTION 23 7313 - AIR HANDLING UNIT - MEDIUM OR LOW PRESSURE

PART 1 GENERAL

1.01 DESCRIPTION

- A. Provide air-handling units of the single-zone draw-thru, blow thru multizone, double wall central station type and size as scheduled on drawings.

1.02 PERFORMANCE

- A. Certify unit components in accordance with AHRI Standard 430 as applicable.
- B. Certify coils in accordance with AHRI Standard 410. Substantiate performance by AHRI computer-generated output.
- C. Furnish coils with minimum rows and fins as scheduled even though performance can be achieved with fewer rows or fins.

PART 2 PRODUCTS

2.01 ACCEPTABLE MANUFACTURERS

- A. Trane, McQuay, York/JCI, Carrier, or approved equal.
- B. Manufacturers both listed above and proposed alternates to review the allowable space for the units considering supply and return airflow, service and maintenance access, coil pull clearance, and piping connections to ensure adequate clearance exists for their units prior to submitting bid. Contractor shall not be allowed extra payment should the low bidder prove to have unacceptable clearance.

2.02 UNIT CONSTRUCTION

- A. Unit sections shall be double wall construction. Exterior wall shall be minimum 18-gage solid galvanized steel. Interior wall shall be minimum 20-gage solid galvanized steel. Unit to be completely insulated with 1" thick, 1-1/2 pound density fiberglass insulation. Insulation shall meet NFPA-90A standards. All connecting channels shall be insulated to prevent sweating. Insulate divider plate between hot and cold deck.

2.03 FAN SECTION

- A. Provide DWDI fan with galvanized or phosphatized painted steel scroll housing. RPM selection shall not exceed 90% of maximum RPM capacity of unit.
- B. Provide air foil fan wheel. Dynamically balance fan before and after installation in the cabinet section.
- C. Provide steel fan shaft keyed, set screwed or clamped to the wheel per the manufacturers standard design to meet the specified performance. Maximum fan rpm to be well below the first critical speed.
- D. Provide units with internally or externally mounted fan motors. Mount motors on slide rail base complete with adjustment nuts. See Specification Section 23 0513 - Electric Motors.
- E. Provide fan section with full sized, hinged, latched, double wall access doors for access to fan, motor, and bearings. Fans with externally mounted motors and bearings may provide removable access panels.

E - N/A
(direct drive)

F. For AHUs 20 horsepower and less, V-belt drive shall be variable pitch, suitable for adjustment within 5 percent of specified RPM. For AHUs 25 horsepower and greater, V-belt drive shall be fixed pitch. Drives shall be selected at 1.5 service factor. Provide belt guard for drive on externally mounted motors.

D - extended lubrication lines not available; lubrication port is located on the front of the fan motor

G. Provide self-aligning, grease-lubricated fan bearings of the ball, roller, or pillow block type. Provide extended lubrication lines from fan bearing to unit casing. Connect lubrication lines to a Zerk fitting mounted on the casing. Select bearings for an average life of 200,000 hours at design operating conditions.

D - rubber pad neoprene isolators provided as standard

H. Mount fan and motor assembly on minimum 2" deflection spring isolators. Fan assembly to be completely isolated from unit bulkhead with flexible neoprene connections.

2.04 COIL SECTION

A. Coil Section:

D - no drain pan under the fan section

1. Provide insulated, double wall, stainless steel construction drain pan extending under the coil and fan sections. Pan shall be sloped to provide positive drainage of condensate. Drain connection(s) are to be provided on the water piping connection side of unit. Coil sections with stacked coils to have an intermediate drain pan with condensate drop tubes to main drain pan.

C

2. Completely enclose coil headers within the insulated casing with piping connections extended through cabinet. Piping connections to be on same end of unit.

C - view IOM for reference

3. Provide coil section with removable access panel or access door to remove coil.

B. Cooling Coils - Direct Expansion (where scheduled on drawings):

E - N/A

1. Provide coils suitable for working pressure of 300 psig. Use pressure type liquid distribution on coil headers. Coils to have gravity oil drainage. Provide solder type coil connections.

2. Dehydrate coils after factory testing and charge with dry air.

3. Design and test coils in accordance with American National Standards Code for Mechanical Refrigeration (ANSI B9.1.).

4. Coils for row or face split operation to have intertwined circuits for equal loading on each circuit.

5. Coils to be constructed of 5/8" outside diameter copper tubing with aluminum fins. Bond fins by mechanical expansion.

C. Cooling Coils - Chilled Water (where scheduled on drawings):

Coil construction info provided on submittal for engineer review

1. Coil to be constructed of 5/8" outside diameter copper tubing with minimum .0075" thick aluminum fins and cast iron or copper headers. Bond fins by mechanical expansion.

2. Provide coils with a maximum working pressure of 175 psig at 200 degrees F.

3. Provide circuited drainable coils with vent connection at highest point and drain connection at lowest point.

4. Coils to be leak tested.

C

D. Heating Coils - Hot Water (where scheduled on drawings):

1. Coil to be constructed of 1/2" or 5/8" outside diameter tubing with minimum .0075" thick aluminum fins and cast iron or copper headers. Bond fins by mechanical expansion.
2. Provide coils with a maximum working pressure of 175 psig at 200 degrees F.
3. Provide circuited drainable coils with vent connection at highest point and drain connection at lowest point.
4. Coils to be leak tested.

Coil construction info provided on submittal for engineer review

C

2.05 ADDITIONAL SECTIONS

A. Filter Section:

1. Refer to Section 23 41 10 - Air Filters.
2. Provide factory-built filter section complete with filters as specified herein. Minimum filter area to be as specified on unit schedule but not to exceed 500 fpm filter face velocity. Filter sections to have full sized, hinged, latched, double wall access doors for filter service.

D - JCI standard air filters provided, air filter specification not provided to JCI with Bid package

Face velocity info provided on the submittal for engineer review

C

- B. Provide a factory mounted Dwyer Magnehelic gage across filter section and mark gage to indicate design clean and dirty loading conditions.
- C. Provide one complete set of replacement filters to Owner at job completion.
- D. Mixing box to have interconnected low-leak type outside and return air dampers with parallel blades. Arrange dampers so outside and return air merge when entering mixing box. Damper rods to rotate in nylon bushings.
- E. Diffuser section: Provide on units as shown on the drawings a field fabricated diffuser section. Construct diffuser plate of 1/16" thick aluminum with 1/2" diameter holes staggered 5/8" center to center, with a minimum free area of 70%. Anchor plate to the housing with angle iron as required.

C - filters must ship within 1 year of unit shipment

D - RA opening comes with CD60 galvanized damper (no OA)

E - to be field provided by others (where required)

PART 3 EXECUTION

3.01 COORDINATION

- A. Prior to purchasing units, refer to drawings and coordinate the required side of unit for motor, access panels and doors, and duct and piping connections to provide proper access clearance.

3.02 INSTALLATION

- A. Install each unit on a minimum 6" high, level, rigid, and heavy concrete base.
- B. Provide proper clearance at each unit for routine service including the changing of filters, removal of coils, bearing greasing, opening of access doors, and pulling of fan shaft.
- C. Ductwork: Duct connections at each unit to allow for straight and smooth airflow. No turns are to be installed at the fan discharge which are in the opposite direction to fan wheel rotation. Provide flexible connections at duct connections to unit.
- D. Piping:
 1. Support piping independently of coils and with adequate flexibility to prevent undue stress at coil header connections.

Done by others



Done by
others



2. Install full size drain lines from the drain pan connection to nearest floor drain and include trap to permit condensate to drain freely. The cooling coil condensate drain piping should be suitably configured and trapped to allow the condensate to drain while the air handling unit is in operation.
3. Install service valves on both supply and return lines to coils and install so valves can be shut off, a small section of pipe removed, and coil allowed to slide out. This condition applies to water and steam coils only.

E - N/A (multizone
not included in base
design)

- E. Submittal data for multizone units to contain zoning damper arrangements for zones indicated on drawings. Indicate CFM for each section.

END OF SECTION

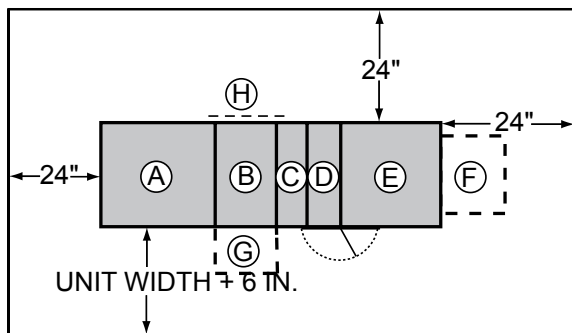
**MIN. CLEARANCE DIMENSIONS**

- Ⓐ Fan Section
- Ⓑ Coil Section
- Ⓒ Face and Bypass Damper Section
- Ⓓ Filter Section - Door should open 180°
- Ⓔ Inlet Section
- Ⓕ Rain Hood (add unit width or length)
- Ⓖ Pipe Chase Enclosure (add to unit width)
- Ⓗ Coil Access Panel on Outdoor Unit (allow clearance = to unit width)

LD6326-4

FIGURE 15 - MINIMUM SERVICE CLEARANCES**Assembling the Johnson Controls Provided Curb**

The curb, which supports the AHU, will be shipped unassembled, and requires assembly on the job site. Assembly drawings and a hardware package, which includes a nailer and gasket, are shipped with each curb. All other parts such as wood or fiber cant strips, roofing felts and material, caulking, and curb-to-roof fasteners are field supplied.

If there are questions about the number of curb parts or assembling the curb, notify a Johnson Controls Field Service Office immediately.

Use the following instructions to assemble the curb:

1. Unpack the shipping package. Layout the parts according to the exploded views.
2. Layout all channel pieces as shown in *Figure 16 on page 27*. Make certain that all channel tabs are located on inside of the mating channel, and that all curb walls, accessories, and flanges, which may have been distorted in handling, are straightened before assembly.
3. Attach the curb walls together to form rectangular perimeter as shown, leaving bolts loose. After the curb is set in place, ensure proper consideration has been given to the air duct openings through the roof.
4. The curb installation drawing shows a gasket that is mounted between the curb and the unit as shown in *Figure 16 on page 27*. This gasket is shipped with the curb parts. Install the curb gasket before setting the AHU on the curb. The gasket forms an

air seal between the AHU and the curb and serves as a dampener, preventing metal-to-metal contact between the AHU and curb. However, the gasket should not be used as a vibration isolator where the prevention of noise and vibration transmission into the building is critical.

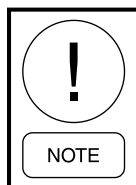

When the AHU is shipped in skids, replace the curb gasket with the caulk provided by contractor.

5. After verifying the curb is square and level, tighten all bolts, and then anchor appropriately. DO NOT tighten the bolts after anchoring because the curb will be pulled, twisted, and torqued out of square.
6. Mark the exact location for the pipe chase curb. Drill and assemble the pipe chase curb. The job submittal drawing package contains a curb drawing that shows the dimensions of the curb and pipe chase.
7. Insulate and roof the curb as required. Refer to Sheet Metal and Air Conditioning Contractors National Association (SMACNA) for counter flash information.

Steel Frame

When a steel frame is used to support the AHU, it must be level, flat without uneven steel frame joints, and support the AHU around the full perimeter. As a general rule, cross members should be placed every 96 in., in addition to each shipping split.

BYPASS COOLING UNIT SCHEDULE

TAG	BCU-1 THRU BCU-61
SERVICE	
MANUFACTURER (BODY)	YORK SOLUTION
MODEL #	XTI-72x126
UNIT DIMENSIONS (LxWxH) INCHES	149 x 126 x 72
UNIT WEIGHT (lbs)	5569
FAN	
SUPPLY CFM	22,500
DRIVE TYPE	DIRECT
VARIABLE FREQUENCY DRIVE	YES
SUPPLY ESP (IN W.C.)	1
SUPPLY TOTAL SP (IN W.C.)	3.93
FAN QUANTITY	2
HP/FAN	15
BRP/FAN	10.34
ELECTRICAL	460/360
FLA	36.2
MCA	40.7
MCCP	50
EMERGENCY POWER (YES / NO)	NO
HIGH EFFICIENCY FILTER	
TYPE	PRIMARY FILTER
DEPTH (IN TYPE)	4" MINI-PLEAT
MEDIA / MERV	60-65% / MERV 11
# OF SPARES	1
HEPA FILTER	
TYPE	PRIMARY FILTER
DEPTH (IN TYPE)	11.5" HEPA
MEDIA / MERV	99.97% EFF / MERV 17
# OF SPARES	1
COOLING CAPACITY (PER COIL)	
NUMBER OF COOLING COILS PER UNIT	1
TOTAL CAPACITY (MBH)	603
SENSIBLE CAPACITY (MBH)	603
CFM THRU COIL	22,500
WATER FLOW RATE (GPM)	100.2
MAX WATER PRESSURE DROP (FT/W.C.)	7.1
MAX AIR PRESSURE DROP (IN W.G.)	0.36
EWT (°F)	42
LWT (°F)	54
EAT (DB °F)	75
LAT (DB °F)	49.5
MIN. # OF ROWS	6
MAX. FACE VELOCITY (FT/MIN)	474
REMARKS	
1. PROVIDE PRESSURE INDEPENDENT MODULATING CHILLED WATER CONTROL VALVES, STRAINER, UNIONS, AND SHUT OFF BALL VALVES	
2. ECM FAN MOTOR WITH VFD	
3. FACTORY PROVIDED CONDENSATE OVERFLOW SWITCH	
4. UNIT MOUNTED DISCONNECT	
5. ALL UNITS TO BE STAINLESS STEEL ON INSIDE WITH STAINLESS STEEL COILS, AND PAINTED EXTERIOR CASING	
6. PROVIDE CONDENSATE PUMP WITH MINIMUM 25 FT LIFT	

AIR ROTATION UNIT SCHEDULE

TAG	ARU-01.03.04.05.06.07	ARU-02.09.10	ARU-08.11	ARU-12
LOCATION	OUTDOOR	INDOOR	INDOOR	OUTDOOR
TYPE	E	E	E	E
MANUFACTURER	MJC	MJC	MJC	MJC
SUPPLY FAN				
SUPPLY CFM *	104,000	104,000	40,000	40,000
O.A. CFM (MIN.)	11,000	11,000	0	0
SUPPLY ESP (IN W.C.)	2.00	2.00	2.00	2.00
SUPPLY TOTAL SP (IN W.C.)	2.65	2.65	2.39	2.39
HP TOTAL# OF FANS	40/2	40/2	30/1	30/1
ELECTRICAL				
FLA				
SUPPLY FAN HP	40*	40*	30*	30*
EMERGENCY POWER (YES/NO)	NO	NO	NO	NO
FILTER				
TYPE	MERV 8	MERV 8	MERV 8	MERV 8
COOLING CAPACITY				
TOTAL CAPACITY (MBH)	4682.57	4682.57	1786.29	1786.29
SENSIBLE CAPACITY (MBH)	3166.74	3166.74	1211.68	1211.68
WATER FLOW RATE (GPM)	582.9	582.9	222.4	222.4
WATER PRESSURE DROP (FT)	17.18	17.18	14.59	14.59
AIR PRESSURE DROP	0.94	0.94	.93	.93
EWT (°F)	42	42	42	42
LWT (°F)	58	58	58	58
EAT (DB °F)	80/67	80/67	80/67	80/67
LAT (DB °F)	51.67/51.64	51.67/51.64	51.81/51.79	51.81/51.79
# OF COILS	2	2	2	2
FINS/FT	156	156	156	156
MIN. # OF ROWS	8	8	8	8
MAX. FACE VELOCITY (FPS)	498	498	494	494
RUNOUT SIZE (IN.)	3	3	2	2
HEATING CAPACITY				
TYPE	HOT WATER COIL	HOT WATER COIL	HOT WATER COIL	HOT WATER COIL
TOTAL CAPACITY (MBH)	4,418.25	4,418.25	1,796.63	1,796.63
WATER FLOW RATE (GPM)	299.3	299.3	121.7	121.7
WATER PRESSURE DROP (FT)	29.61	29.61	23.10	23.10
AIR PRESSURE DROP	0.57	0.57	.08	.08
EWT (°F)	140	140	140	140
LWT (°F)	110	110	110	110
EAT (DB °F)	50	50	50	50
LAT (DB °F)	87.7	87.7	90	90
FINS/FT	72	72	84	84
MIN. # OF ROWS	5	5	3	3
MAX. FACE VELOCITY (FPM)	996	996	409	409
RUNOUT SIZE (IN.)	3	3	2	2
UNIT DIMENSIONS (LxWxH) INCHES	109x216x366	109x216x366	105x93x246	105x93x246
UNIT WEIGHT (lbs)				
REMARKS	1 THRU 4	1 THRU 4	1 THRU 4	1 THRU 4
* INDICATES PREMIUM EFFICIENCY MOTORS WITH VFD				
TYPE:	A. MODULAR CHILLED WATER AIR HANDLING UNIT - SECTIONS IN DIRECTION OF AIRFLOW: TOP RETURN PLENUM; RETURN FAN; RELIEF SECTION TOP DISCHARGE; OUTSIDE AIR SECTION TOP INTAKE; FILTER SECTION; PRE-HEAT STEAM COIL; COOLING COIL; SUPPLY FAN; SUPPLY PLENUM TOP AND BOTTOM DISCHARGE			
	B. MODULAR CHILLED WATER AIR HANDLING UNIT - SECTIONS IN DIRECTION OF AIRFLOW: REAR RETURN PLENUM; RETURN FAN; RELIEF SECTION TOP DISCHARGE; OUTSIDE AIR SECTION TOP INTAKE; FILTER SECTION; PRE-HEAT STEAM COIL; COOLING COIL; SUPPLY FAN; SUPPLY PLENUM TOP AND BOTTOM DISCHARGE			
	C. MODULAR CHILLED WATER AIR HANDLING UNIT - SECTIONS IN DIRECTION OF AIRFLOW: TOP RETURN PLENUM; RETURN FAN; RELIEF SECTION TOP DISCHARGE; OUTSIDE AIR SECTION TOP INTAKE; FILTER SECTION; COOLING COIL; SUPPLY FAN; SUPPLY PLENUM TOP AND BOTTOM DISCHARGE			
	D. MODULAR CHILLED WATER AIR HANDLING UNIT - SECTIONS IN DIRECTION OF AIRFLOW: TOP RETURN PLENUM; RETURN FAN; RELIEF SECTION TOP DISCHARGE; OUTSIDE AIR SECTION TOP INTAKE; FILTER SECTION; PRE-HEAT STEAM COIL; COOLING COIL; REHEAT COIL; STACK SUPPLY FAN TOP DISCHARGE			
	E. MODULAR CHILLED WATER AIR HANDLING UNIT - SECTIONS IN DIRECTION OF AIRFLOW: BOTTOM RETURN PLENUM; OUTSIDE AIR SECTION BOTTOM INTAKE; FILTER SECTION; PRE-HEAT HOT WATER COIL; COOLING COIL; SUPPLY FAN; SUPPLY PLENUM TOP DISCHARGE			
REMARKS:	1. PROVIDE PRESSURE INDEPENDENT MODULATING CHILLED CONTROL VALVES, STRAINER, UNIONS, AND SHUT OFF BALL VALVES			
	2. ARU-8 IN OUTBOUND WAREHOUSE TO DISCHARGE SUPPLY AIR MINIMUM 50 FT A.F.F.			
	3. FACTORY PROVIDED CONDENSATE OVERFLOW SWITCH			
	4. UNIT MOUNTED DISCONNECT			

AIR HANDLING UNIT SCHEDULE

TAG	AHU-SPINE-01 THRU 08	AHU-GEN-01 THRU 08	AHU-01	AHU-02	AHU-03	AHU-04	AHU-05.06.07.08	HTA-01 THRU 03	CG-01 THRU 06	FAHU-01 THRU 03	RTS-01 THRU 06	VOF-01 THRU 06
SERVICE	1ST FLOOR SPINE	GENERAL PLANT	ANODE MIXING	ANODE MIXING	ANODE COATER HEAD	ANODE COATER END	CATHODE/ANODE OVENS	HTA TUNNELS	CAPACITY GRADING	FORMATION	RT STANDING	VOF POWER SUPPLY
MANUFACTURER	YORK	YORK	YORK	YORK	YORK	YORK	YORK	YORK	YORK	YORK	YORK	YORK
MODEL #	XTI-108x108	XTI-132x138	XTI-63x93	XTI-132x126	XTI-126x126	XTI-126x126	XTI-132x132	XTO-132x120	XTO-132x120	XTO-132x120	XTO-132x138	XTI-51x66
SUPPLY FAN												
SUPPLY CFM	30,000	50,000	13,500	35,000	40,000	40,000	45,000	38,500	42,000	40,500	50,000	7,000
O.A. CFM (MIN.)	6,000	0	13,500	0	0	0	0	0	0	0	0	0
DRIVE TYPE	DIRECT	DIRECT	DIRECT	DIRECT	DIRECT	DIRECT	DIRECT	DIRECT	DIRECT	DIRECT	DIRECT	DIRECT
DESIGN FAN SPEED (RPM)	2,115	1,776	2,458	2,079	2,079	2,079	1,785	2,436	1,770	1,770	1,971	1,343
MAX FAN SPEED (RPM)	2,269	2,269	2,771	2,269	2,269	2,269	2,269	2,675	2,269	2,269	2,269	2,269
SUPPLY ESP (IN W.C.)	3.00	1.00	4.00	3.00	3.00	3.00	1.5	2.0	1.5	1.5	1.5	1.00
SUPPLY TOTAL SP (IN W.C.)	5.33	2.95	7.15	7.68	6.69	6.69	3.70	4.61	4.42	4.57	4.63	2.67
MIN. MOTOR HORSEPOWER	2 @ 20 EACH	4 @ 15 EACH	2 @ 15 EACH	4 @ 20 EACH	4 @ 20 EACH	4 @ 20 EACH	4 @ 15 EACH	4 @ 15 EACH	4 @ 15 EACH	4 @ 15 EACH	4 @ 20 EACH	1 @ 7.5 EACH
VFD	2	2	2	2	2	2	2	2	2	2	2	1
PREHEAT COIL												
TOTAL CAPACITY (MBH)			531				1,981					
SENSIBLE CAPACITY (MBH)			531				1,981					
WATER FLOW RATE (GPM)			27.0				101.0					
WATER PRESSURE DROP (FT)			8.5				7.0					
AIR PRESSURE DROP			.07				.12					
EWT (°F) / LWT (°F)			140/100				140/100					
EAT (DB °F)			15				50					
LAT (DB °F)			50.0				90.6					
FINS/INCH			12				11					
MIN. # OF ROWS			1				2					
MAX FACE VELOCITY (FPM)			457				450					
FLUID VELOCITY (FPS)			4.7				3.6					
HEATING COIL												
TOTAL CAPACITY (MBH)		2169	517	1,319				640	1,917	1,864	2,290	
SENSIBLE CAPACITY (MBH)		2169	517	1,319				640	1,917	1,864	2,290	
WATER FLOW RATE (GPM)		110.6	35.1	89.3				38.3	97.5	94.9	116.7	
WATER PRESSURE DROP (FT)		8.6	6.1	1.3				3.4	6.0	5.7	9.5	
AIR PRESSURE DROP		0.13	0.10	0.09				0.39	0.14	0.13	0.14	
EWT (°F) / LWT (°F)		140/100	140/110	140/109.9				140/106	140/100	140/100	140/100	
EAT (DB °F)		50	50	50				105	50	50	50	
LAT (DB °F)		90	84.8	84.3				120.1	91.9	92.5	92.3	
FINS/INCH		11	8	8				12	12	12	12	
MIN. # OF ROWS		2	2	2				2	2	2	2	
MAX FACE VELOCITY (FPM)		476	457	431				428	469	450	476	
FLUID VELOCITY (FPS)		4	2.9	1.9				1.4	3.5	3.4	4.2	
COOLING COIL												
TOTAL CAPACITY (MBH)	1,223	1,385	1,416	1,750	1,068	1,068	1,994		1,857	1,893	2,183	194
SENSIBLE CAPACITY (MBH)	860	1,385	675	1,115	897	897	1,237		676	1,244	1,463	194
WATER FLOW RATE (GPM)	153.1	172.4	176.8	217.5	133.4	133.4	247.3		229.9	236.9	271.7	24.1
WATER PRESSURE DROP (FT)	19.3	3.3	21.8	10.5	8.4	8.4	17.2		13.8	14.6	7.9	6.3
AIR PRESSURE DROP	0.64	0.31	1.01	0.79	0.39	0.39	0.5		0.62	0.68	0.72	0.25
EWT (°F) / LWT (°F)	42/58	42/58	42/58	42/58	42/58	42/58	42/58		42/58	42/58	42/58	42/58
EAT (DB °F)	79/65.2	80/55	97/81	80/67	75/62	80/67	80/67		80/67	80/67	80/67	80/55
LAT (DB °F)	51.9/50.8	54.5/43.6	49.0/48.8	49.9/49.5	54.7/52.7	54.7/52.7	54.1/52.4		53.6/52.5	52.4/51.5	53.7/52.7	53.4/43.2
FINS/INCH	11	8	12	11	10	10	10		10	11	11	10
MIN. # OF ROWS	6	6	8	8	5	5	6		6	6	6	5
MAX FACE VELOCITY (FPM)	474	474	457	431	449	449	450		469	450	476	439
FLUID VELOCITY (FPS)	4.6	2.1	2.9	3.4	3.1	3.1	4.4		4.1	4.2	3.3	2.4
FILTER												
TYPE	2" MERV 08	2" MERV 08			2" MERV 08		2" MERV 08	2" MERV 08	2" MERV 08	2" MERV 08	2" MERV 08	2" MERV 08
FILTER SIZES	24x24	24x20			24x24		24x24	24x24	24x24	24x24	24x24	24x24
UNIT DIMENSIONS (LxWxH) (IN)	228x120x114	210x150x138	222x126x84	226x138x120	237x142x134	237x142x134	234x144x138	242x156x141	310x156x141	287x156x141	311x174x142	115x78x57
UNIT WEIGHT (lbs)	10,000	15,350	10,000	14,000	15,400	15,400	17,500	18,600	18,500	20,000	20,000	3,000
REMARKS	1 THRU 4	1 THRU 4	1 THRU 4	1 THRU 4	1 THRU 4	1 THRU 4	1 THRU 4	1 THRU 4	1 THRU 4	1 THRU 4	1 THRU 4	1 THRU 4
1. PROVIDE PRESSURE INDEPENDENT MODULATING CHILLED CONTROL VALVES, STRAINER, UNIONS, AND SHUT OFF BALL VALVES E - by others												
2. PROVIDE 120V 20A CIRCUIT FOR LIGHTS AND CONTROLS. D - controls to be provided by others												
3. FACTORY PROVIDED CONDENSATE OVERFLOW SWITCH. E - by others												
4. UNIT MOUNTED DISCONNECT D -												

Project Coordination / Release for Fabrication



PROJECT COORDINATION

Release for Fabrication Notes

Release for Fabrication Requirements:

1. **Purchase Order (scanned or hard copy).** Document must state "Purchase Order". Purchase Requisition, Purchase Request, and other similar documents which do not reflect "Purchase Order" will not be considered.
2. **Approved Submittals.** Stamped on the submittal or sent through email. Verbal and text message approvals will not be considered.
3. **Release Confirmation.** Stamped on the submittal or sent through email formalizing the release of equipment. Verbal and text message release confirmation will not be considered.
 - a. Any "**SUBMITTAL NOTES**" or "**EQUIPMENT RELEASE APPROVAL FORM**" page(s) must be filled out.
 - b. Any **HANDING COORDINATION** documents must be confirmed and filled out.
 - c. Any **DRAWINGS** or **PERFORMANCE** sheets needs to be verified and signed off.

Lead times do not start until release requirements are met.

Revisions After Release:

1. Equipment will be ordered and manufactured based on the approved submittal.
2. Any **revisions AFTER release** will have to be approved by the corresponding JCI factory.
3. Revision approval will **solely depend on the JCI factory**. The local JCI office does not have the authority to approve any revisions AFTER release.
4. Revisions AFTER release **may incur additional costs for approval**. These costs are not part of the original contract price and will be processed as a Change Order.
5. Revisions AFTER release **may affect lead time**. This impact will be relayed to the customer prior to revision approval. Any lead time estimates/promises made before the revision will be null and void.
6. Revisions AFTER release that require additional costs will not be processed unless a Change Order for the revision is submitted to JCI.
7. Revisions AFTER release include, but are not limited to the following:
 - a. Project name change.
 - b. Unit(s) tag number change.
 - c. Unit(s) performance revisions (includes changes in input parameters such as CFM, temperatures, gpm, capacity, electrical ratings, OSHPD/seismic certifications, etc.)
 - d. Unit(s) drawing revisions (includes changes in nozzle configurations, intake/discharge orientations, dimension modifications, weight reduction, OSHPD/seismic certifications, etc.)
 - e. Change in BOM (includes, scope of work, warranty, items provided, items excluded, quantity, etc.)

Long Term Storage

If the equipment is not planned to be started before six (6) months from the date of shipment, or if the area they are going to be stored in will be subject to unusual atmospheric conditions (including within 5 miles of salt water/shipped over salt water). If these conditions exist, please contact your JCI representative for JCI's long term storage recommendations and a quote for delayed startup to maintain unit(s) warranty.

Units not started up within 6 months will not have warranty, unless notified by customer of needing this requirement prior to 6 months from shipment.

Installation, Operation, & Maintenance Manuals

One physical copy of IOMs for detailed information on shipping and receiving ships with unit. Additional digital copies are available upon request.

Shipping & Receiving

Shipping

JCI consolidates loads and non-standard shipments aren't part of JCI scope, unless specifically included in the quote. All non-standard shipments will require a change order. Non-standard shipment include but are not limited to:

- Shipping units or sections in a certain order
- Shipping 1 unit per truck
- Shipping units by floor

Receiving

It is the installing contractor's responsibility to verify the following prior to signing the bill of lading presented by the transportation company:

- Ensure everything on the bill of lading was delivered
- Visually perform a thorough inspection of all equipment for any signs of shipping damage

Any short-shipments or shipping damage must be noted on the bill of lading prior to signing.

Loose Items Shipment Notes (If Included with Order, See Bill of Materials)

Look inside cabinets, base rails, etc for ship loose items that the ship with units. Certain ship loose items may not arrive at the same time as units.

AHUs:

- Filters shipped separately to the units. Customers to direct where and when to ship filters at least 2 weeks prior to unit(s)' shipment. Spare filters ship at the same time as the first set of filters.

SOLUTION SEGMENT IDENTIFICATION

FAN SEGMENTS

- FS – Supply
 - Forward Curved
 - Airfoil
 - Industrial Airfoil
 - SWSI Plenum (Belt and Direct Drive)
- FR – Return
 - Forward Curved
 - Airfoil
 - Industrial Airfoil
 - SWSI Plenum (Belt and Direct Drive)
- FE – Exhaust
 - Forward Curved
 - Airfoil
 - Industrial Airfoil

COIL SEGMENTS

- CC – Cooling Coil
- HC – Heating Coil
- VC – Vertical Coil
- MZ - Multizone

HEAT SEGMENTS

- IC – Integral Face & Bypass Coil
- IG – Indirect Gas Fired Furnace
- EH – Electric Heater

ENERGY RECOVERY

- ER – Energy Recovery

FILTER SEGMENTS

- FF – Flat Filter (2" or 4")
- AF – Angle Filter (2" & 4")
- RF – High Efficiency Filter
 - Rigid Filter (12")
 - Bag Filter (21")
 - Mini-Pleat Filter (4")
- HF – HEPA Filter

INLET SEGMENTS

- MB – Mixing Box
- FM – Filter/Mixing Box
- EF – Filter/Economizer
- EE – Economizer
- IP – Inlet Plenum
- VE – Vertical Economizer
- VF – Vertical Filter/Economizer

ACCESSORY SEGMENTS

- VP – Vertical Plenum
- DP – Discharge Plenum
- TN – Turning Plenum
- DI – Diffuser
- XA – Access segment
- AB- Air Blender
- EB – External Bypass
- IB – Internal Bypass
- FD – Face Damper
- AT – Attenuator
- HM - Humidifier
- UV - UVC Lamps

Unit & Coil Hand Identification

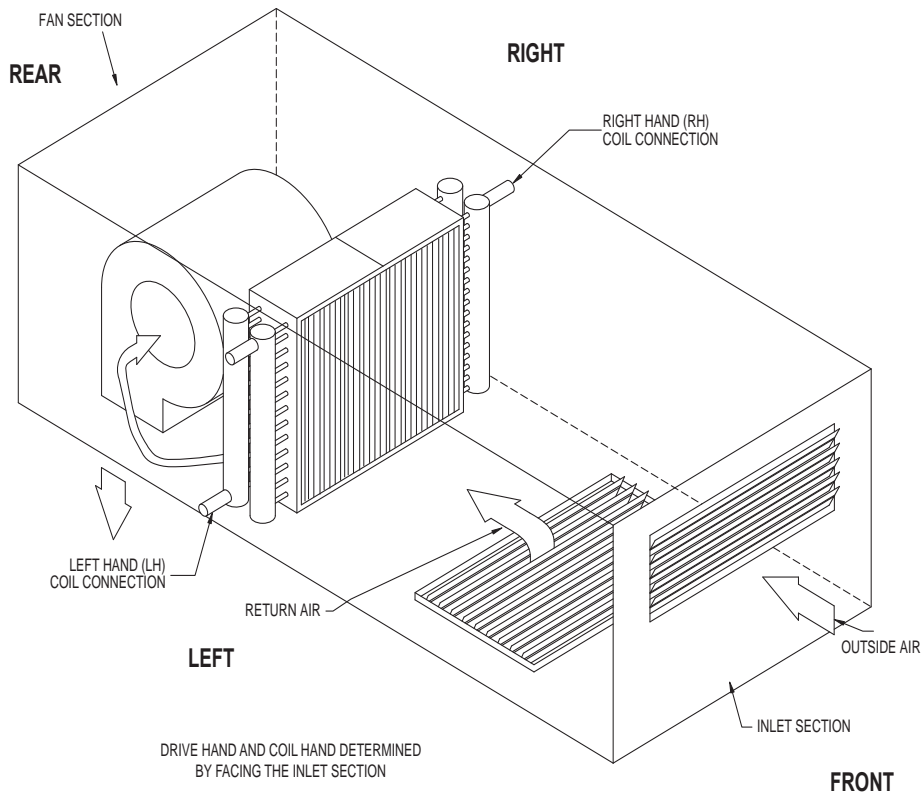

AHU Equipment Release / Configuration Process

Attached you will find preliminary drawings representing the unit(s) we submitted on this project. Please review these forms, make any required modifications, sign each page indicating your approval and then fax them back to my attention. Please note that equipment cannot be released for fabrication until these forms are completed and returned with your signature of approval. Please feel free to contact our office if you have any questions regarding the attached information.

Unit Section	Items for Review	Potential Configurations
Supply Fan	Supply /Return Fan Discharge Location (see below)	Top, Top Inverted, Bottom, Bottom Inverted, Rear, Rear Inverted
	Supply /Return Fan Motor Location	Left or Right
	Fan Motor Voltage & Phase	208, 230, 460, 480, Single or Three Phase
Coils (CHW, HW, DX, EH)	CHW Cooling Coil Hand Connections	Left or Right
	DX Cooling Coil Hand Connections	Left or Right
	Heating Coil Hand Connections	Left or Right
	DX Coil Circuits	One or Two
	Electric Heat Voltage & Phase	208, 230, 460, 480, Single or Three
	Condensate Drain Connection	Left or Right
Plenums	Discharge Plenum Openings (if required)	Left, Right, Top, Bottom
	Inlet Plenum Openings (If required)	Left, Right, Top, Bottom, Front
	Inlet Plenum Dampers (if required)	Left, Right, Top, Bottom, Front (Specify Return Air & Outside Air)
Electrical	VFD Location (if required)	Left or Right
	Starter Location (if required)	Left or Right
	Disconnect Location (if required)	Left or Right
	Power connections	Single Point or Multiple Point
General	Unit Height	Please review contract drawings to approve attached dimensions
	Unit Width	Please review contract drawings to approve attached dimensions
	Unit Length	Please review contract drawings to approve attached dimensions
	Unit Weight	Please review and approve
	Access Door Locations (if required)	Left, Right or Both
	Roof Curb (if required)	Check height, slope and coil hand locations
	Shipping Splits (if required)	See Note #9 below

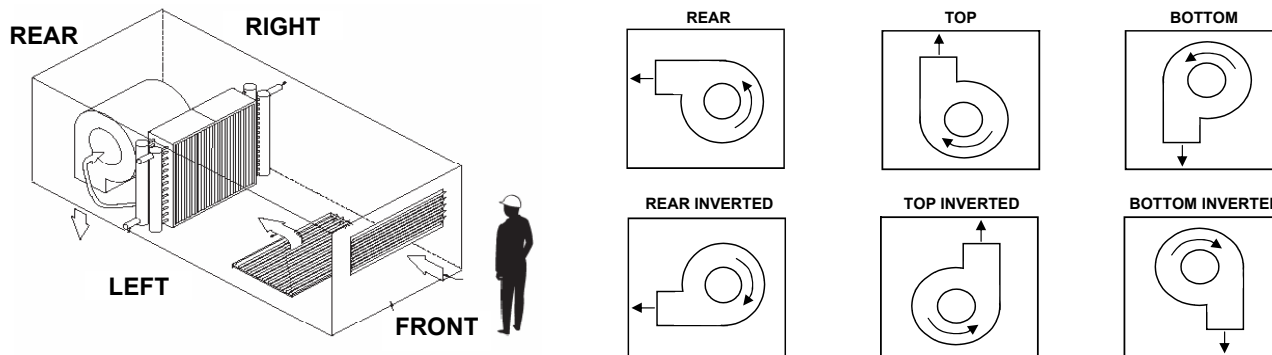

NOTE: Drive hand and coil hand determined by facing the inlet section

Important Notes:

- 1) Actual fabrication release cannot commence until this form is **confirmed by the customer and returned to JCI**
- 2) The release process cannot commence until **written** release notification is issued by customer including **want date** and **ship to address**
- 3) Equipment "**lead-time**" **does not start** until confirmed release documentation is received
- 4) Modifications to equipment configurations after fabrication release may impact cost and lead-time
- 5) Attached configurations are as shown in the approved equipment submittals or as defined in superseding customer correspondence
- 6) AHU "Side" / "Hand" orientation is relative to a person standing inside an AHU with air hitting the back of the head. See drawing above.
- 7) Note that once this document is confirmed, the equipment configurations defined by this document take precedence over all other documents
- 8) "Want date" and/or "ship to address" changes made after this document is confirmed may impact cost and lead-time
- 9) The attached drawings also include shipping split explosions with corresponding weights and dimensions. If additional splits are required there will be additional cost and the unit length will increase.

Equipment Release Approval Form

SUBMITTAL NOTES

The following table must be completed prior to releasing the equipment for fabrication. Please initial the column indicating the information contained in this submittal has been verified, or indicate to refer to a marked-up page.

SUBMITTAL VERIFICATION	
	Purchaser Initials
Electrical voltage and electrical connections are compatible with jobsite requirements.	
Piping / Ductwork connections shown in this submittal are correct .	
Unit tag designations are correct.	

SUBMITTAL VERIFICATION	
	Purchaser Initials
Indicate equipment configuration choices on the Equipment Release /Configuration Process form (if included on this Submittal package), and sign the form.	

Important Notes:

- 1) Actual fabrication release cannot commence until this form is signed by the customer and returned to JCI along with a release notification want date and ship to address.
- 2) Equipment "lead-time" does not start until confirmed release documentation is received, and the order is actually released to the factory.
- 3) Modifications to equipment configurations after fabrication release may impact cost and lead-time

Please fill out the following table and refer to the receiving/rigging instructions in this submittal to help ensure a smooth delivery and installation of the equipment.

DELIVERY INFORMATION	
	Please fill out information below
Contact name for coordinating delivery of equipment with transportation company	
Contact phone number	
Advance notice required from transportation company prior to delivering equipment (typically 48 hours)	
Ship to address:	
Other special shipping instructions or requirements	

FILTER DELIVERY INFORMATION

Instructions: Please fill out the following table for timely delivery of the filters and ensure they are not lost or damaged until it is time for unit startup.

Please fill out information below:	
Primary contact name, number, and email for coordinating delivery of filters with transportation company	
Alternate delivery contact name, phone number, and email (if applicable)	
Advance notice required from transportation company prior to delivery (typically 48 hours)	
Ship-to address	
Requested delivery date (NOTE: Subject to factory lead time)	
Other special shipping instructions or requirements	
Has the site agreed to accept the delivery of the filters? (YES or NO)	
Will the delivery truck be required to have a lift gate? (YES or NO)	



Bill of Material and Scope Details

Product Type: Semi-Custom Air Handling Units

Unit Tags: Various

C. OUTDOOR AIR HANDLING UNITS: TAGs: RTS-01 ~ RTS-06

Furnish Eighteen (18) Outdoor Air Handling Units with 460/3/60 power furnished with the following sections:

- ❖ Economizer Mixing Box
- ❖ Filter Section
- ❖ Cooling coil
- ❖ Heating Coils
- ❖ Supply Fan
- ❖ Discharge Plenum

FURNISHED WITH THE FOLLOWING FEATURES AND ACCESSORIES:

- ❖ Unit Options:
 - Unit casing deflection no greater than L/240 at 8" of static pressure
 - Maximum leakage of 1% at 8" of static pressure
 - **GALVANIZED STEEL INTERIOR LINER**
 - 2" double wall construction
 - **CHAMPAGNE URETHANE EXTERIOR PAINT**
 - 6" base rail
 - 15 Amp GFI outlet provided in the supply fan segment
 - Vapor proof LED lights
- ❖ Economizer Mixing Box:
 - Low leakage dampers
- ❖ Filter Segment:
 - Two (2) sets of 2" MERV 8 pleated filters
 - Magnehelic filter gauge
- ❖ Cooling and Heating coil segments:
 - Galvanized steel bulkhead, support, and casings
 - Stainless steel drain pan
 - **EXTERIOR PIPE CHASE WITH ACCESS DOOR**
- ❖ Supply Fans:
 - Direct drive plenum fan array
 - Premium efficiency motor with shaft grounding rings
 - Factory mounted VFDs **(2 VFDs Total per Unit)**
 - Fan Airflow Monitoring
- ❖ Start-Up & Warranty:
 - JCI Factory Startup
 - Standard Eighteen (18) month parts and labor warranty from shipment or twelve (12) months from startup, whichever occurs first.
 - **ADDITIONAL 1 YEAR OF PARTS AND LABOR WARRANTY (2 YEARS TOTAL) TO EXTEND WARRANTY THROUGH 1 YEAR POST SUBSTANTIAL COMPLETION**

ITEMS NOT INCLUDED (ALL SCOPE ABOVE):

- ❖ Controls
- ❖ Smoke detectors
- ❖ Wiring or installation of control components
- ❖ Piping or piping specialties
- ❖ Hauling, Unloading, Rigging, Installation and Re-Assembly of Equipment
- ❖ Taxes, Delayed Shipment, Expedited Freight, and Long Term Storage
- ❖ Extended Warranty
- ❖ Factory or Field Leakage and Deflection Testing



Performance Ratings & Unit Drawings

Product Type: Semi-Custom Air Handling Units

Unit Tags: Various

Job Summary

Project Name:	Envision 2 SC Outdoor Units		
Unit Tag(s):	RTS-01, RTS-02, RTS-03, RTS-04, RTS-05, RTS-06		
Quantity:	6	Environment:	Outdoor



Unit Overview

Model	Airflow (CFM)	Altitude (ft)	Weight (lbs)
XTO-132x138	50,000	0	18,409

Segment Sequence

(DP)(FS)(XA HC CC)(FF MB)

Unit Construction

Casing Details

Segment(s)	Thickness (in)	Exterior Paint	Exterior Gauge and Material	Interior Gauge and Material	Insulation Thickness and Material	Mylar Lining	Thermal Break	Bulkhead Material
MB, XA, DP	2"	Champagne Urethane 3,500 Hr	18 Ga. G-90 Galvanized	Standard Ga. G-90 Galvanized	2" Foam	-	-	None
FF, CC, HC, FS	2"	Champagne Urethane 3,500 Hr	18 Ga. G-90 Galvanized	Standard Ga. G-90 Galvanized	2" Foam	-	-	Galvanized Steel

Base Details

Segment(s)	Material	Paint
MB, FF, CC, HC, XA, FS, DP	6" Formed Steel	Champagne Urethane 3,500 Hr

Floor Details

Segment(s)	Gauge and Material	Paint	Insulation	Thermal Break	Attachment	Sub-Floor Gauge and Material
MB, FF, CC, HC, XA, FS, DP	Standard Ga. G-90 Galvanized	None	2"	-	Screw Down	None

Notes

Enhanced Thermal Performance construction.

High Humidity OA construction.

A curb rest will be provided with the unit.

Vestibule/Pipe Chase

Casing Details						
Segment(s)	Thickness (in)	Exterior Paint	Exterior Gauge and Material	Interior Gauge and Material	Insulation Thickness and Material	Depth
PC	2"	Champagne Urethane 3,500 Hr	18 Ga. G-90 Galvanized	Standard Ga. G-90 Galvanized	2" Foam	36"

Floor Details						
Segment(s)	Gauge and Material	Paint	Insulation	Thermal Break	Attachment	Sub-Floor Gauge and Material
PC	Standard Ga. G-90 Galvanized	None	2"	-	Screw Down	None

Notes

Openings in vestibule/pipe chase floor to be field cut by others unless indicated otherwise. Refer to IOM for procedures for cutting openings. Vestibule/pipe chase floor is designed to support a maximum point load of 300 lbs. Equipment to be installed and attached in the field. Vestibule/Pipe Chase must be reviewed with the factory prior to release for fabrication to ensure proper structural design of vestibule/pipe chase floor.

Vestibule/pipe chase roof is not designed to be used to support field installed piping, ductwork, exhaust hoods, etc.

Unit Electrical

Circuit Details					
#	Component(s)	V/Ph/Hz	Full Load Amps (FLA)	Minimum Current Ampacity (MCA)	Maximum Overcurrent Protection (MOP)
1	Manual Motor Protector on FS,VFD on FS	460/3/60	48	54	70
2	Manual Motor Protector on FS,VFD on FS	460/3/60	48	54	70
3	Electrical Outlet and Light Switch on FS	120/1/60	-	-	20

Electrical Details			
Minimum Unit SCCR	10 kA rms Symmetrical	ETL Label (UL1995/NEC-2002)	
Unit Light Type		Light Switch Enclosure	
LED		Outdoor	

Supply Fan(s)

Performance Details													
Fan Manufacturer	Model	# Blades	Class	Size	% Wheel Width	% Wheel Diameter	Quantity	Airflow per Fan (CFM)	Altitude (ft)	TSP (in w.g.)	ESP (in w.g.)	Fan Speed (RPM)	Fan Power (BHP)
Lau	SF	9	II	245	120	100	4	12,500	0	4.72	1.50	1,980	15.58
Max RPM	Wheel Type	Blade Type	Wheel Material	Base Material	Fan Flow Isolation	AirFlow Monitoring	Inverter Drive Balancing	Isolation Type	Thrust Restraints				
2,269	SWSI	Airfoil	Aluminum	-	Damper	Yes (K=2941.00)	-	Rubber Pad	-				
Drive Type	FEI	FEP (KW)	Inlet Screen	Fan Cage	Fan Stand	Motor Removal Rail	Seismic Snubber						
Direct Drive	0.28	53.43	-	-	-	-	-						
Motor Details													
Type / MFG	Motor Power (HP)	V/Ph/Hz	Quantity	Insulation Class	RPM	Frame Size	FLA (Amps)	Efficiency	Location	SGR			
TEFC / Baldor	20.0	460/3/60	4	H	1,800	256T	24.00	Premium	Left	Yes			
At Motor Synchronous Details													
TSP (in w.g.)	Total Air Flow (CFM)	Fan Speed (RPM)	Fan Power (BHP)										
3.77	11,174	1,770	11.13										

Notes

Certified by the AHRI Central Station Air-Handling Unit (AHU) Certification Program, based on AHRI Standard 430/431. AHRI certified units are subject to rigorous and continuous testing, have performance ratings independently measured and are third-party verified. Certified units may be found in the AHRI Directory at www.ahridirectory.org

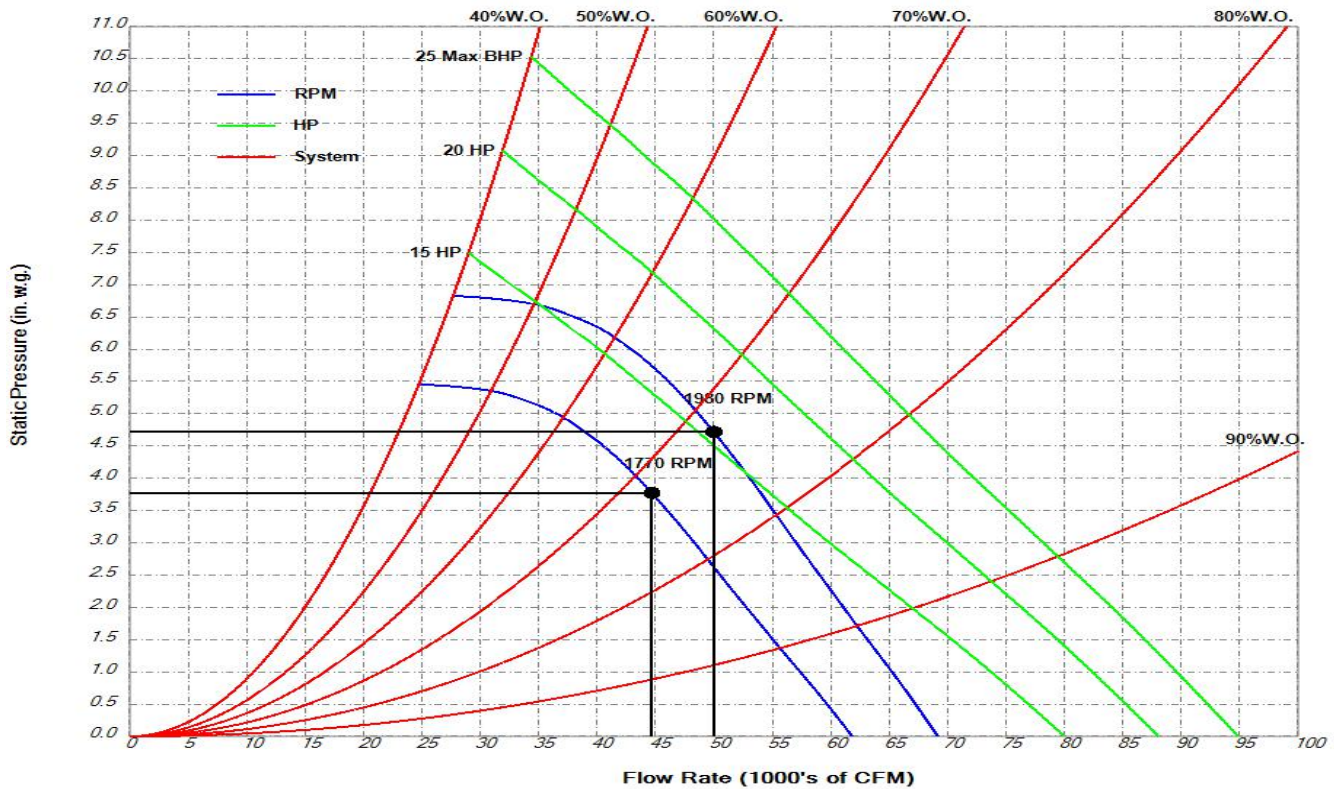

Water Coil(s)

Coil Information

Segment[Index]	Coil Tag	Coil Duty	Fluid Type	Airflow (cfm)	Flow Direction	Density	Altitude (ft)
CC[1]	-	Cooling	Water	50000	Horizontal	Standard	0
HC[1]	-	Heating	Water	50000	Horizontal	Standard	0

Coil Bank Configuration

Segment[Index]	Tube Diameter (in) Fin Type	Total Fin Height (in)	Fin Length per Coil (in)	Face Velocity (fpm)	Stacking Rack Material	Coils High	Coils Wide	Coil Configuration	Coil Stagger (in)	Coil Pull Panel
CC[1]	0.500 Corrugated	120.00	126.00	476	-	3	1	Standard	0	Left Side
HC[1]	0.500 Corrugated	120.00	126.00	476	-	3	1	Standard	0	Left Side

Airside Performance

Segment[Index]	EAT-DB (°F)	EAT-WB (°F)	LAT-DB (°F)	LAT-WB (°F)	TMBH	SMBH	Air Pressure Drop (in w.g.)
CC[1]	80.0	67.0	53.7	52.7	2183	1463	0.72
HC[1]	50.0	-	92.3	-	2290	2290	0.14

Fluidside Performance

Segment[Index]	EFT (°F)	LFT (°F)	Fluid Velocity (fps)	Fluid Flow (gpm)	Fluid Pressure Drop (ft)	Rows	Tubes Per Circuit	Reynolds Number
CC[1]	42.0	58.0	3.3	271.7	7.9	6	4	9500
HC[1]	140.0	100.1	4.2	116.7	9.5	2	4	28892

Fin and Tube Configuration

Segment[Index]	Fin Thickness (in) / Material	Fin Spacing (fpi)	Tube Thickness (in)	Return Bend Thickness	Casing Material	Coil Coating	Fouling Factor (hr.ft ² .°F/BTU)
CC[1]	0.008 Aluminum	11	0.016	0.016	Galvanized	None	-
HC[1]	0.008 Aluminum	12	0.016	0.016	Galvanized	None	-

Header and Connection Configuration

Segment[Index]	Header Material	Connection Material	Connection Diameter (in)	Connection Offset (in)	Connection Type	Connection Location/Rotation
CC[1]	Copper	Steel	3	0	MPT	Left
HC[1]	Copper	Steel	2.5	0	MPT	Left

Other Performance

Segment[Index]	Dry Weight (lbs)	Fluid Weight (lbs)	Internal Volume (ft ³)
CC[1]	1773	531	9.1
HC[1]	780	204	3.4

Notes

- Performance is shown for the entire coil bank. Performance is not per coil.
- Coil index indicates position in segment. Example: CC-1, index 1; Spacer, index 2; CC-1, index 3
- Ratings are for coils manufactured by Johnson Controls, Inc., 507 E. Michigan St., Milwaukee WI 53202.
- All Coils: Johnson Controls suggests using red brass or copper connectors when the coil is to be attached to a copper or brass piping system.
- This coil is certified in accordance with the AHRI Forced-Circulation Air-Cooling and Air-Heating Coils Certification Program which is based on AHRI Standard 410 within the range of Standard rating conditions listed in Table 1 of the Standard. Certified units may be found in the AHRI Directory at www.ahridirectory.org.
- All Coils: AHRI Certified: Yes. Certified in accordance with the AHRI Forced-Circulation Air-Cooling and Air-Heating Coils Certification Program which is based on AHRI Standard 410 within the range of Standard rating conditions listed in Table 1 of the Standard. Certified units may be found in the AHRI Directory at www.ahridirectory.org.
- All Coils: BDW Tube Spacing: 1.25 x 1.08
- All Coils: Coil DII Version: 8.2

Drain(s)

Details			
Segment	Drain Pan		
	Liner Material	Connection Location	Liner Coating
CC	Stainless Steel, 304	Right	None

Filter(s)

Details							
Segment	Type	Depth	Filter Loading	Media/MERV	# of Spares	Spare Filter Media	Frame Material
FF	Primary Filter	2"	Side	Pleated 30% Efficiency (MERV 8)	1	Pleated 30% Efficiency (MERV 8)	Galvanized Steel

Sizes						Filter Gauge Details		
Segment	Filter	1 st Filter Size H x W (in)	1 st Qty	2 nd Filter Size H x W (in)	2 nd Qty	Location	Type	Range (in w.g)
FF	Primary Filter	24x20	20	24x24	10	Door	Magnehelic with Flag	0 - 2.0

Damper(s)

Details												
Segment	Air Path	H x W (in)	Qty	Total Face Velocity (ft/min)	Face Area (ft ²)	Airflow (CFM)	Min Airflow Measurement (CFM)	Type	Config	Model	Material	Blade Orientation
MB	Return Air	39.00 x 100.00	1	1,846	27.1	50,000	-	Control	100%	CD60	Galvanized	Parallel
FS	Inlet Air	37.25 x 37.68	4	1,282	39.0	50,000	-	Counterbalanced Backdraft	100%	CBD6	Aluminum	Parallel

Door(s)

Details												
Segment(s)	Location	Swing	Hinge Location	H x W x T (in)	View Port	ViewPort Wire	Test Port	Spare Gasket	Thermal Break	Fastener Type	Safety Latch	Noncontact Safety Interlock
MB	Left	Outward	Front	78 x 18 x 2	Standard Double Pane	-	Yes	-	Yes	Plated	-	-
FF	Left	Outward	Front	126 x 10 x 2	None	-	-	-	Yes	Plated	-	-
FF	Right	Outward	Front	126 x 10 x 2	None	-	-	-	Yes	Plated	-	-
CC	Right	Outward	Rear	78 x 18 x 2	Standard Double Pane	-	Yes	-	Yes	Plated	-	-
XA	Left	Outward	Front	78 x 18 x 2	Standard Double Pane	-	Yes	-	Yes	Plated	-	-
DP	Left	Outward	Rear	78 x 24 x 2	Standard Double Pane	-	Yes	-	Yes	Plated	Yes	-
PC	Left	Outward	Front	129 x 18 x 2	None	-	-	-	-	Plated	-	-
PC	Left	Outward	Rear	129 x 18 x 2	None	-	-	-	Yes	Plated	-	-

Motor Control(s)

VFD Details									
Segment	Type	V/Ph/Hz	Input/Output Amps*	Efficiency (%)	Heat Loss (at 100% load)	Enclosure	Bypass	Disconnect Type	RFI/EMI EMC Filter
FS	AYK-580	460/3/60	52/52	98	835	NEMA 3R	-	Fused	Yes
FS	AYK-580	460/3/60	52/52	98	835	NEMA 3R	-	Fused	Yes

Notes (ABB VFD)

*Drives are rated for use below 3,000 ft and 104°F. Refer to the Air-Mod Engineering Guide Form 100.42-EGI (813) for additional information.

Drives are current rated devices. The HP ratings provided are for reference only and are based on typical 4-pole motors at nominal voltages (NEC Table 430-150). If full motor torque is required, ensure the drive has a continuous current rating equal to, or greater than, the full load amp rating of the motor.

Storage Temperature: -40°F to 158°F (-40°C to 70°C).

Ambient Operating Temperature: Temperate 5°F to 104°F (-15°C to 40°C). De-rating to operate at 122°F (50°C).

Relative Humidity: 5% to 95% non-condensing. Maximum relative humidity is 60% in the presence of corrosive gasses.

Altitude: 100% Load Capacity (No De-rating) up to 3,300 ft. (1,000 m). 1% derating for each 330 ft. above 3,300 ft. Installations above 6,600ft. (2,000 m) require review.

If 8KHZ Switching Frequency is used, de-rate output current to 80%.

Overload Current Rating: 110% for 1 minute every 10 minutes and is capable of 130% short term-overload rating for 2 seconds our of each minute.

If applicable, motor overload protection in the bypass mode is provided by a Class 20 motor overload relay.

The customer is responsible for providing either a platform/catwalk or portable means to access the VFD when the VFD is installed where the center of the handle of the disconnecting means in its uppermost position is greater than 78" above the finished floor.

Input line Impedance: 5% Equivalent Input Impedance with internal reactor(s). Patented swinging choke design for superior harmonic mitigation.

Use Copper Conductors Only. Do not use aluminum wire.

Manual Motor Protection Details

Location Segment	Disconnect Type	Enclosure Type	V/Ph/Hz	# of Fans Served	Motor HP (Each)
FS	None	NEMA 3R	460/3/60	4	20
FS	None	NEMA 3R	460/3/60	4	20
Total Combined HP	Total Amps	Drain/Vent Assembly	Service	# of Circuits	
80	48	-	Supply Fan motor(s)	2	
80	48	-	Supply Fan motor(s)	2	

Notes

Use Copper Conductors Only. Do not use aluminum wire.

The Class 10 trip rating of the MMP device will not withstand an across-the-line start of a fan and should not be used with VFDs with bypass circuits.

Face Velocity and Static Pressure

Summary						
Segment	Description	Face Area (ft ²)	Airflow (CFM)	Face Velocity (ft/min)	Supply Fan Static Pressure (in w.g.)	Exhaust/Return Fan Static Pressure (in w.g.)
MB	CD60 (Control Damper 60 - Galvanized Airfoil)	27.1	50,000	1,846	0.04	0.00
MB	Safety Cover	27.1	50,000	1,846	0.37	0.00
MB	Return Air Opening	27.1	50,000	1,846	0.57	0.00
FF	2" Pleated 30% Efficiency (MERV 8)	106.7	50,000	469	0.26	0.00
FF	Dirty Filter Allowance	0.0		0	0.50	0.00
CC	Cooling - 6 Row - 11 Fins Per Inch	105.0	50,000	476	0.72	0.00
HC	Heating - 2 Row - 12 Fins Per Inch	105.0	50,000	476	0.14	0.00
FS	CBD6 (Backdraft Damper With Counterbalance)	39.0	50,000	1,282	0.09	0.00
FS	External Static - User Entered	0.0		0	1.50	0.00
DP	Safety Cover	36.0	50,000	1,389	0.21	0.00
DP	Supply Air Opening	36.0	50,000	1,389	0.32	0.00
Total					4.72	0.00

Dimensions and Weight

Details					
Segment	Description	Length ¹ (in)	Height (in)	Width ² (in)	Weight ³ (lbs)
MB	Mixing Box	53	132	138	2,330
FF	Flat Filter	13	132	138	440
CC	Cooling Coil	44	132	138	3,549
HC	Heating Coil	18	132	138	1,507
XA	Access	21	132	138	546
FS	Fan (Supply)	98	132	138	6,923
DP	Discharge Plenum	64	132	138	2,382
Overall		311			

Notes

¹The length includes bottom tier segments only.

²The width does not include coil connection extensions or door latches that extend beyond the unit casing. The width does not include the depth of any pipe chases.

³See Shipping Summary for notes on weights.

Recommended Trap Height

Details									
Segment	Applicable Fan	Fan TSP (in w.g.)	Positive or Negative	Calculated Dimensions (in)			Recommended Dimensions (in)		Base Rail Height (in)
				H	X	H + X	H	H + X	
CC	Supply Fan	4.72	Negative	4.96	2.48	7.44	5.00	7.50	6

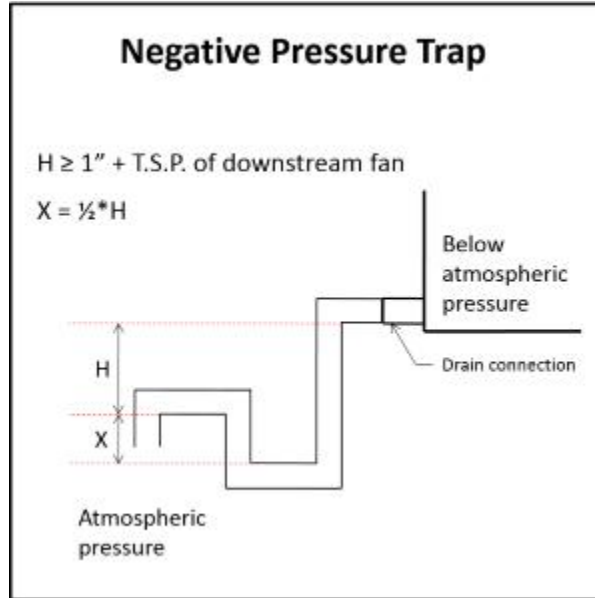

Notes

Formulas and calculations are recommendations only. Contractor shall determine actual dimensions required for each trap based on jobsite conditions, and application requirements.

Refer to the Installation Manual of the IOM for more information.

Statement of Compliance

Details

Air Handling Unit AHU's meet IBC seismic requirements for non-critical equipment ($I_p = 1.0$) for locations with design spectral response $S_d \leq 0.43$. Units must be rigid mounted.

The anchorage of the unit to the ground or building structure needs to be evaluated by and is the responsibility of the engineer of record. Specification of seismic requirements is the responsibility of the project design engineer. If formal certification is required, please contact your sales representative and/or application engineer for review. Certain application and site requirements may require additional cost and/or lead time.

Component locations are listed as Segment Hand (Unit Hand): ex. Left (Right). See Submittal Drawing for additional details.

Air handling unit parameters vary depending on conditions. Parameters such as airflows, air pressure drops, and coil capacities are shown for design conditions.

Shipping Summary

Details				
Skid	Skid Length (in)	Skid Height (in)	Skid Width (in)	Skid Weight (lbs)
FF MB	70	144	146	2,798
XA HC CC	86	144	146	4,895
FS	101	144	159	6,951
DP	67	144	146	2,410
Pipe Chase(s)	N/A	N/A	N/A	732
Overall				17,786

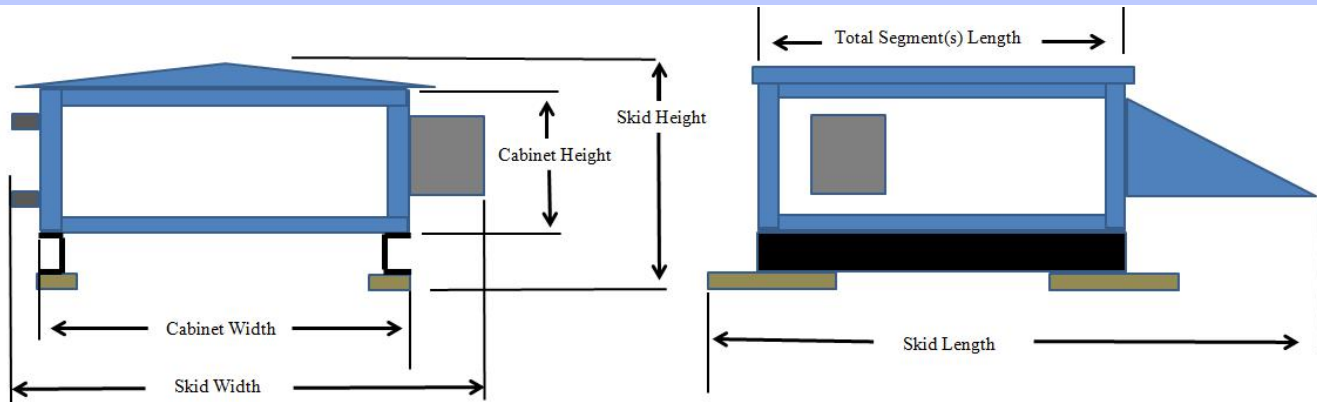

Notes

Skid Width: Total width of the shipping skid, including any items that may extend beyond the cabinet (this includes any door handles, coil connections, drain connections, lifting lugs, mounted pipe-chases, electrical/control components, tie-down brackets, side dampers).

Skid Height: Total height of the shipping skid, including any items that may extend beyond the cabinet (this includes any base-rails, shipping wood-blocks, roof peak, discharge flanges, mounted gas-furnace flue pipes).

Skid Length: Total length of the shipping skid, including any items that may extend beyond the cabinet (this includes any mounted rain-hoods, discharge flanges, tie-down brackets, shipping wood-blocks, front dampers, split connectors, electrical/control components, outriggering extensions, isolation dampers, inlet baskets).

Skid Weight: Weight values represent the estimated operational weight with a tolerance of +/- 10% for values greater than 5,000 lbs. Values less than 5,000 lbs. may have higher percentage variation but not any consequential shipping impact. Operational weight estimate includes unit shell, internal components and structure, and known ship loose and/or field-installed items (weather hoods, pipe chases, factory-provided filter media and estimated fluid weight in coils). Actual operating weight will be heavier due to additional field installed materials including but not limited to field-provided filter media, piping, control devices, and/or inertia base concrete.

Special Request(s)

Details				
Location	Number	Description	Resolution	Status
Unit	26844-002	500 dollar MLP add to order form per Maryann's email.	**INFORMATION ONLY**Revision charge per Customer Service.	In Progress
MB	26844-003	Post-Release to add custom RA damper only. Overall length to be kept the same as before (311 inches).Maryann approval email attached to add 500 MLP for this revision. Please see attachments.		In Progress

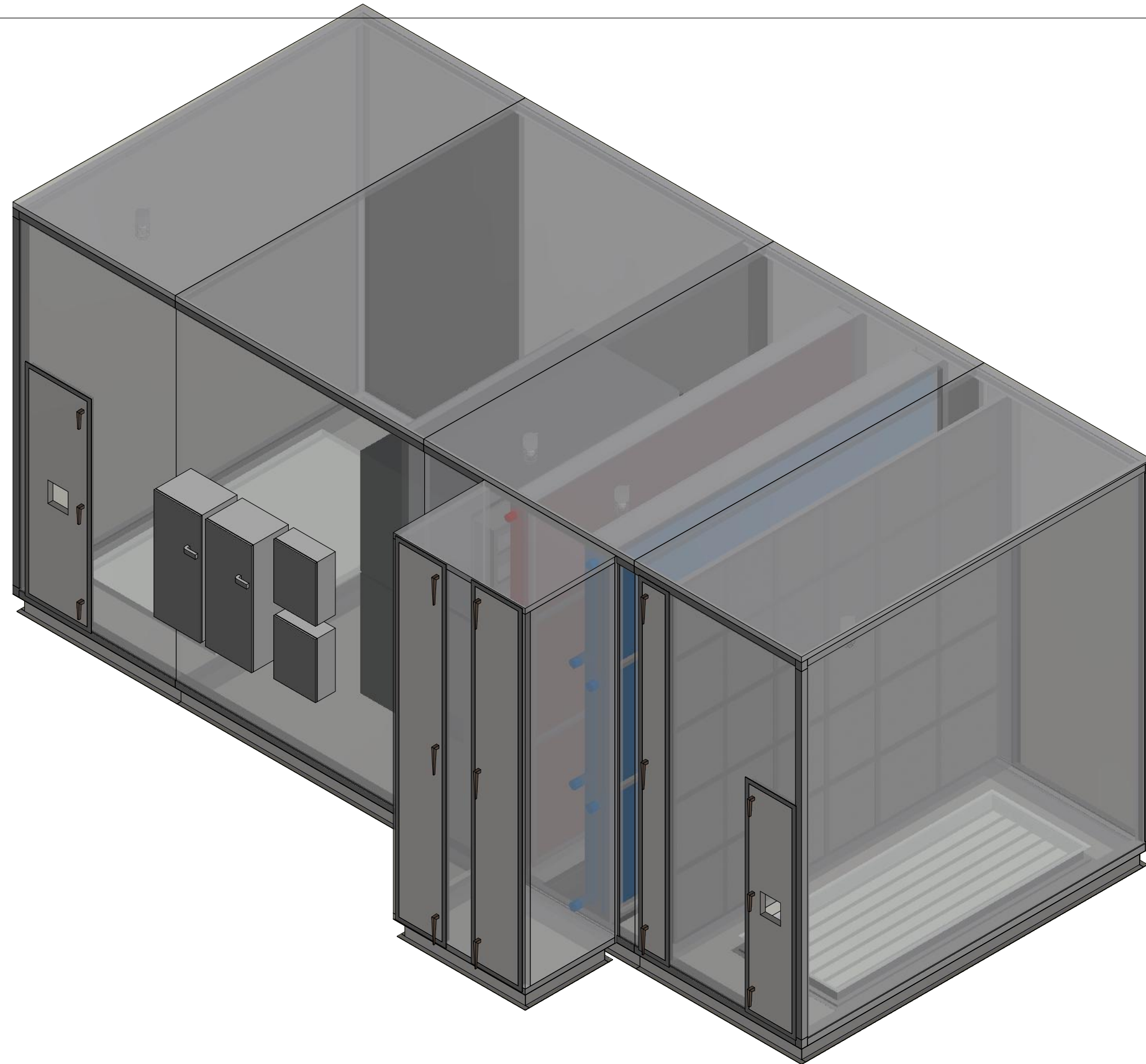

REV	DATE	REVISION CHANGE	REV BY

YORK SOLUTION UNIT DRAWING
 MODEL: XTO-132x138 05/08/2024 01:22:28 PM UTC
 DESIGNATION: RTS-01
 PROJECT NAME: ENVISION 2 SC OUTDOOR UNITS

ISOMETRIC VIEW
 SHEET 1 OF 6 CONTRACT#: 4E-H40118-04
 UNIT TAG: **RTS-01, RTS-02, RTS-03, RTS-04, RTS-05, RTS-06**

ALL DIMENSIONS SHOWN IN: INCHES
 DRAWING SCALE: NTS
 DIMENSION TOLERANCES: UNIT (+/- 1/2"); PIPING (+/- 2")
 WEIGHT: 18409 (+/- 10%)
DRAWING NOT TO BE USED FOR CONSTRUCTION

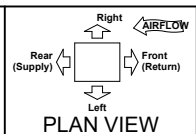

PLAN VIEW

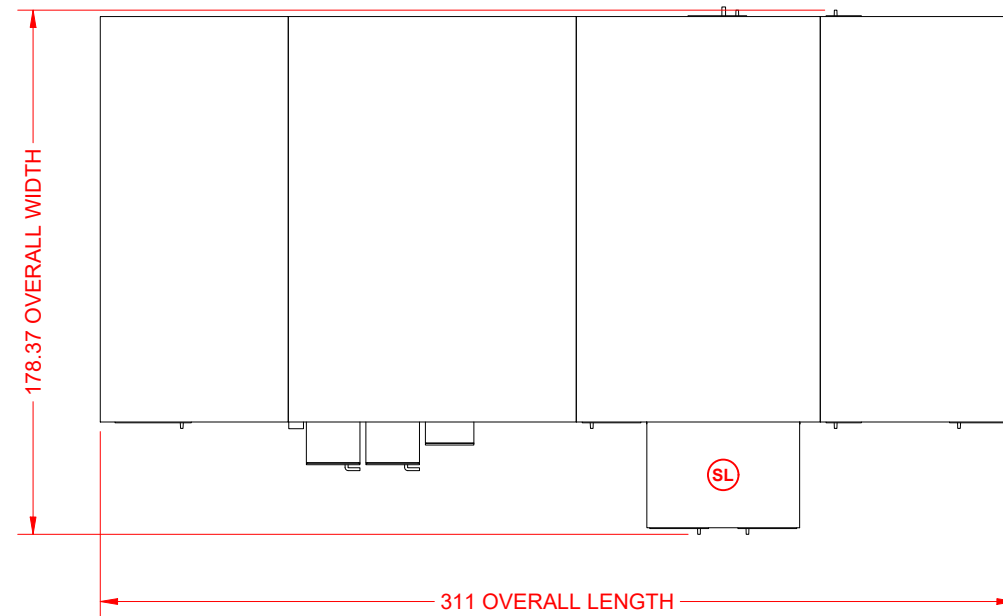

NOTES:

UNITS WITH A BASERAIL AND A BOTTOM OPENING: DUCT CONNECTION FLUSH WITH THE BOTTOM OF UNIT, NOT FLUSH WITH BOTTOM OF BASERAIL.

REFER TO PERFORMANCE REPORT FOR SHIPPING SPLIT DETAILS.

ALLOW SUFFICIENT SPACE AROUND THE UNIT FOR REMOVING THE ACCESS PANELS AND VARIOUS PARTS OF THE UNIT. A MINIMUM CLEARANCE EQUAL TO THE WIDTH OF THE UNIT MUST BE PROVIDED ON ONE SIDE OF THE UNIT FOR REMOVING THE COIL OR FAN ASSEMBLY.

CONTRACTOR RESPONSIBLE FOR PENETRATIONS AND CONNECTIONS OF ALL ELECTRICAL BOXES AND INTERNAL COIL CONNECTIONS (IF PRESENT).

OVERALL DIMENSIONS ACCOUNT FOR COMPONENTS EXTENDING BEYOND UNIT CABINET IN ORDER TO CONVEY THE TRUE SPACE REQUIREMENTS FOR THE UNIT. THESE ITEMS MAY INCLUDE OUTDOOR ROOF PEAK, MOTOR CONTROL AND/OR FACTORY PACKAGE CONTROL BOXES, WEATHER HOODS, PIPE CHASES, DAMPER/LOUVER ASSEMBLIES, AND/OR UNIT BASE RAIL.

CERTAIN ITEMS MAY EXTEND BEYOND CABINET DIMENSIONS INCLUDING: COIL CONNECTIONS, ROOF TRIM, DOOR HANDLES, LIGHT SWITCHES, ELECTRICAL PANEL HANDLES, LIFTING LUGS, GAS FUEL SYSTEM, ETC.

THE OVERALL UNIT LENGTH MAY INCLUDE ADDITIONAL 1/4" PER SHIPPING SPLIT (IF APPLICABLE) FOR GASKET AND CONNECTION HARDWARE.

FILTER DIMENSIONS ARE NOMINAL SIZES.

ELECTRICAL DEVICES (LIGHTS, SWITCHES, PANELS, ETC.) INDICATE GENERAL AREA OF UNIT (E.G., SEGMENT); FINAL PLACEMENT DETERMINED DURING MANUFACTURING.

REAR VIEW

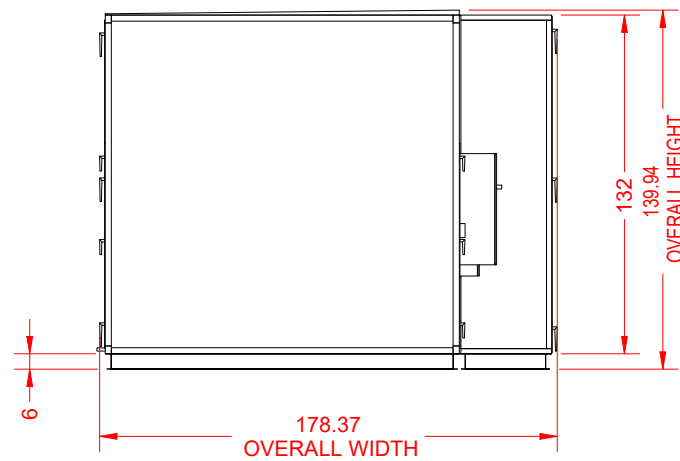

ELEVATION VIEW LEFT

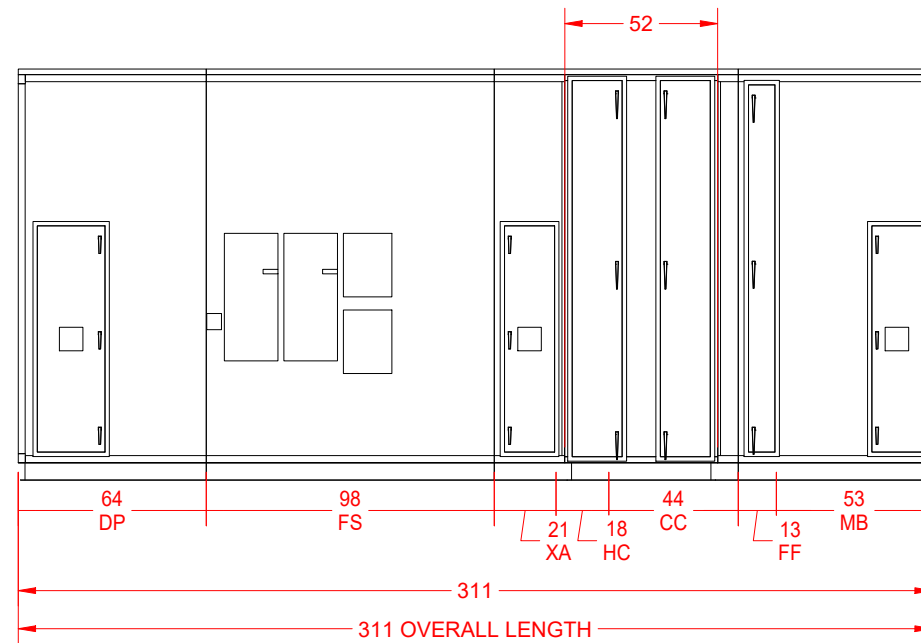

FRONT VIEW

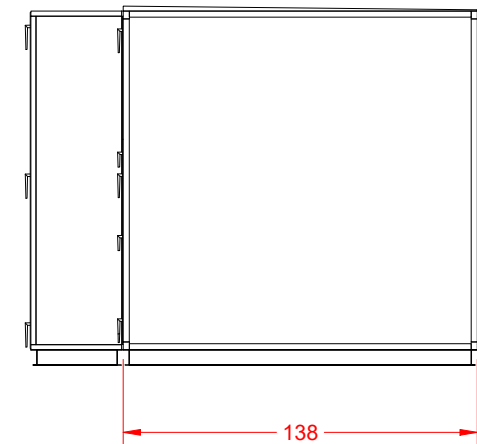

REV	DATE	REVISION CHANGE	REV BY

YORK SOLUTION UNIT DRAWING
 MODEL: XTO-132x138 05/08/2024 01:22:28 PM UTC
 DESIGNATION: RTS-01
 PROJECT NAME: ENVISION 2 SC OUTDOOR UNITS

EXTENTS VIEW
 SHEET 2 OF 6 CONTRACT#: 4E-H40118-04
 UNIT TAG: **RTS-01, RTS-02, RTS-03, RTS-04, RTS-05, RTS-06**

ALL DIMENSIONS SHOWN IN: INCHES
 DRAWING SCALE: NTS
 DIMENSION TOLERANCES: UNIT (+/- 1/2"); PIPING (+/- 2")
 WEIGHT: 18409 (+/- 10%)
DRAWING NOT TO BE USED FOR CONSTRUCTION

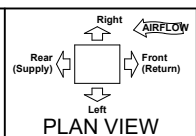

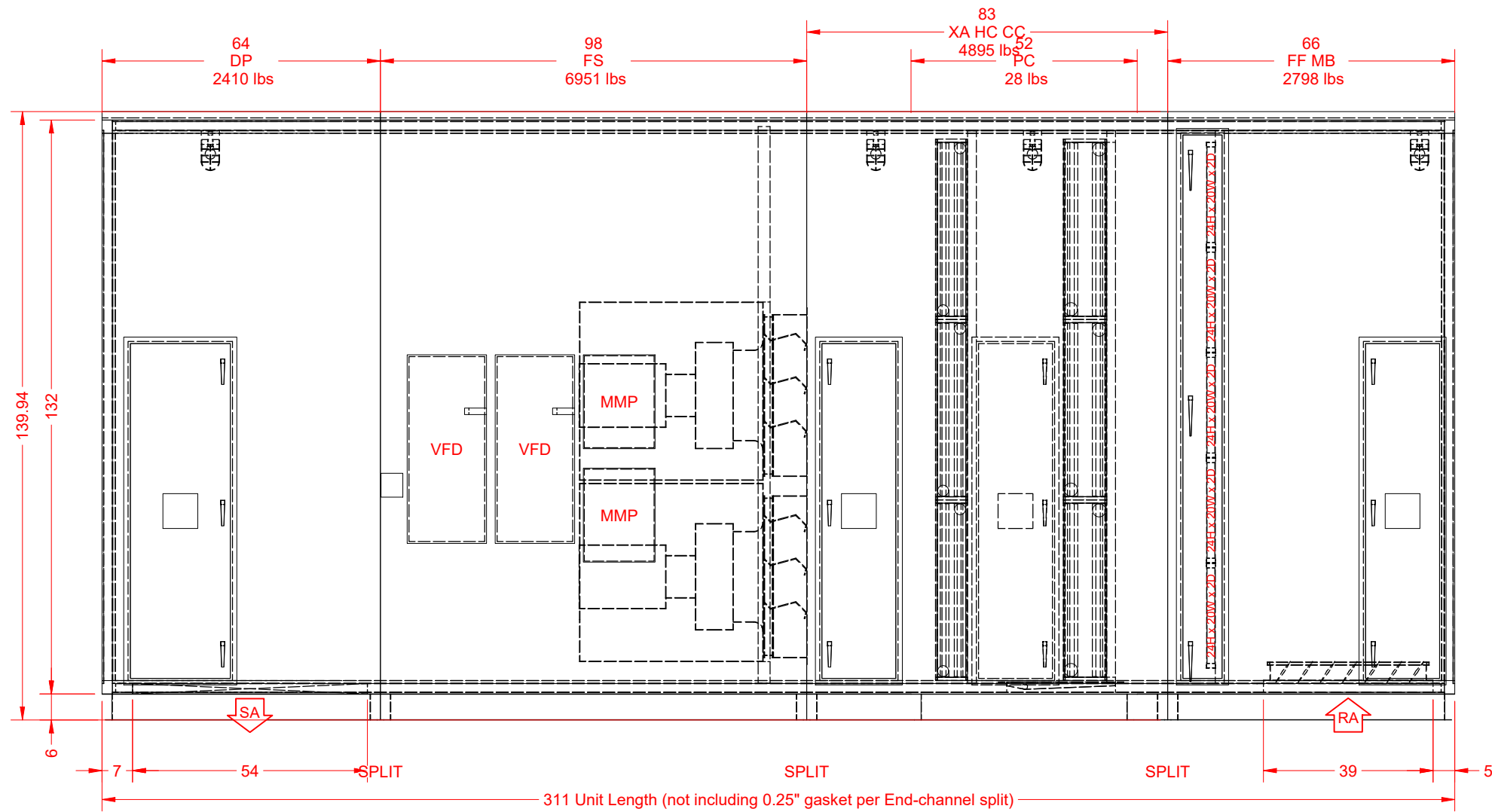

REV	DATE	REVISION CHANGE	REV BY

YORK SOLUTION UNIT DRAWING

MODEL: XTO-132x138 05/08/2024 01:22:28 PM UTC

DESIGNATION: RTS-01

PROJECT NAME: ENVISION 2 SC OUTDOOR UNITS

ELEVATION VIEW

SHEET 3 OF 6 CONTRACT#: 4E-H40118-04

UNIT TAG: **RTS-01, RTS-02, RTS-03, RTS-04, RTS-05, RTS-06**

ALL DIMENSIONS SHOWN IN: INCHES

DRAWING SCALE: NTS

DIMENSION TOLERANCES: UNIT (+/- 1/2"); PIPING (+/- 2")

WEIGHT: 18409 (+/- 10%)

DRAWING NOT TO BE USED FOR CONSTRUCTION

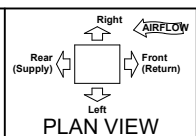

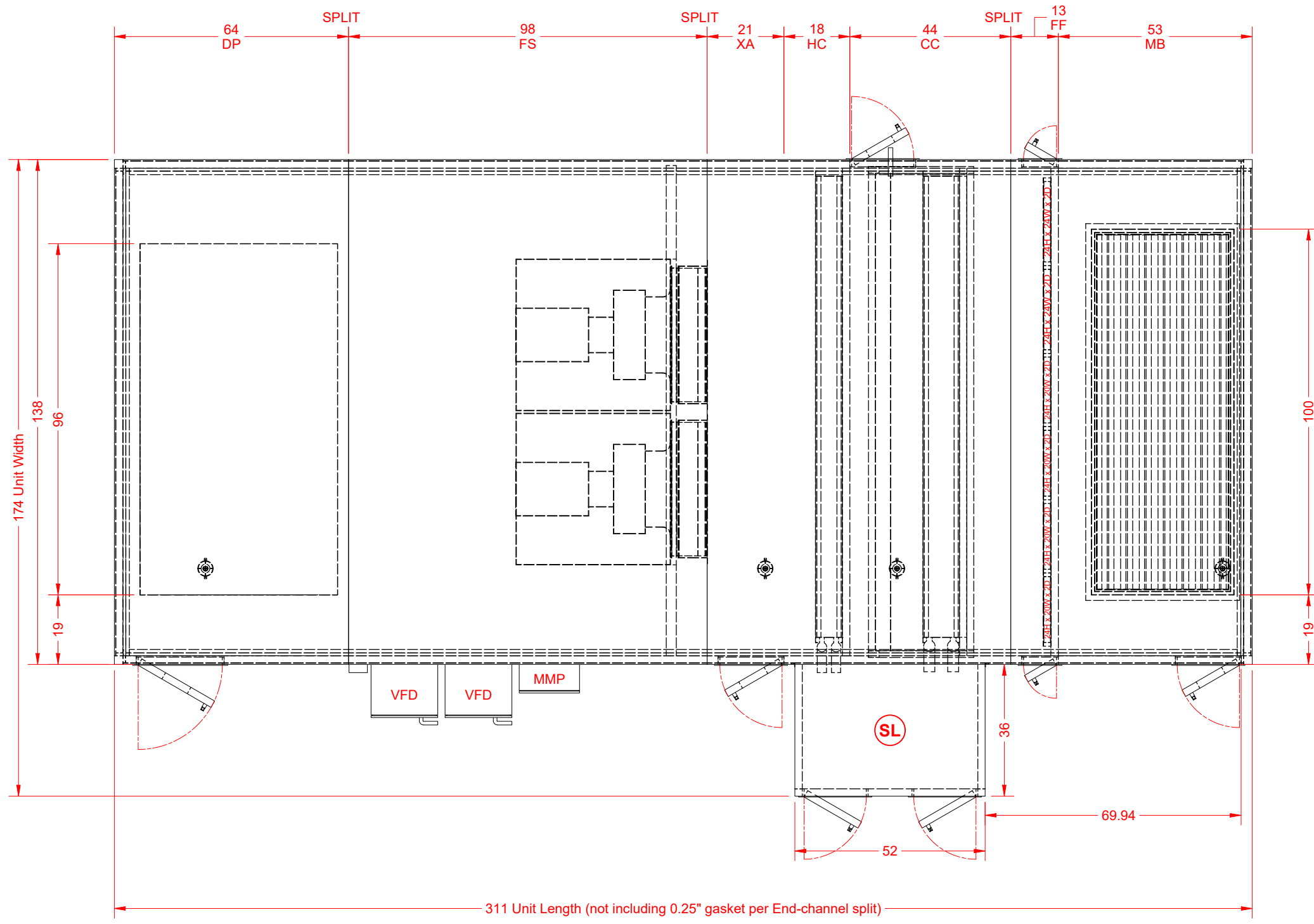

REV	DATE	REVISION CHANGE	REV BY

YORK SOLUTION UNIT DRAWING
 MODEL: XTO-132x138 05/08/2024 01:22:28 PM UTC
 DESIGNATION: RTS-01
 PROJECT NAME: ENVISION 2 SC OUTDOOR UNITS

PLAN VIEW
 SHEET 4 OF 6 CONTRACT#: 4E-H40118-04
 UNIT TAG: **RTS-01, RTS-02, RTS-03, RTS-04, RTS-05, RTS-06**

ALL DIMENSIONS SHOWN IN: INCHES
 DRAWING SCALE: NTS
 DIMENSION TOLERANCES: UNIT (+/- 1/2"); PIPING (+/- 2")
 WEIGHT: 18409 (+/- 10%)
DRAWING NOT TO BE USED FOR CONSTRUCTION

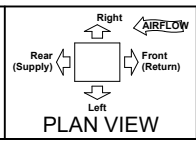

COIL CONNECTIONS							
CNCT	XDIM	YDIM	SEG	HAND	TYPE	SIZE	SRVC
S1	193.4	11.2	HC	LEFT	MPT	2.5	SPLY
S4	222.8	11.5	CC	LEFT	MPT	3	SPLY
R4	229.3	48.2	CC	LEFT	MPT	3	RTRN
R1	197.3	48.5	HC	LEFT	MPT	2.5	RTRN
S2	193.4	52.7	HC	LEFT	MPT	2.5	SPLY
S5	222.8	53.0	CC	LEFT	MPT	3	SPLY
R5	229.3	89.7	CC	LEFT	MPT	3	RTRN
R2	197.3	90.0	HC	LEFT	MPT	2.5	RTRN
S3	193.4	94.2	HC	LEFT	MPT	2.5	SPLY
S6	222.8	94.5	CC	LEFT	MPT	3	SPLY
R6	229.3	131.2	CC	LEFT	MPT	3	RTRN
R3	197.3	131.5	HC	LEFT	MPT	2.5	RTRN
DRAIN CONNECTIONS							
CNCT	XDIM	YDIM	SEG	HAND	TYPE	SIZE	SRVC
D1	212.2	7.7	CC	RIGHT	-	1.25	DRAIN

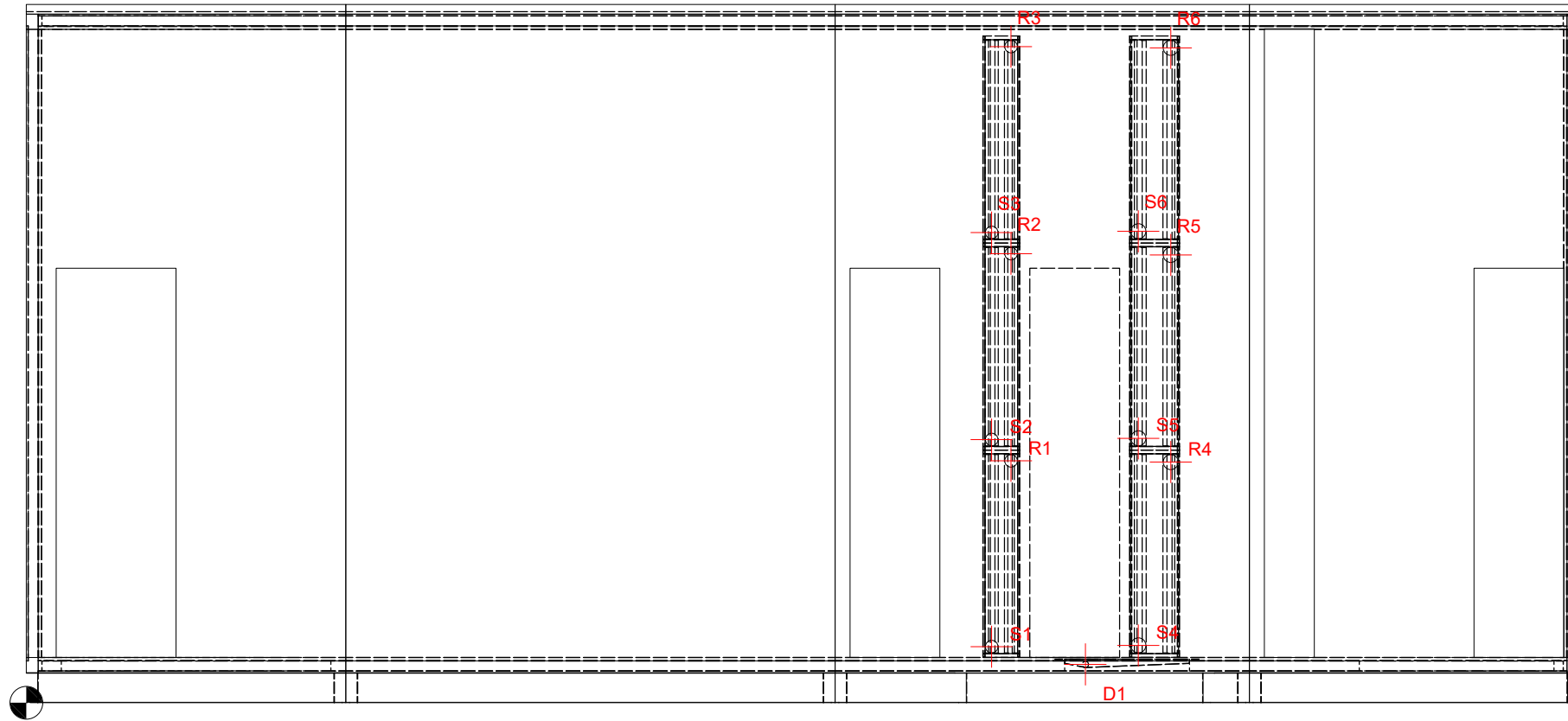

REV	DATE	REVISION CHANGE	REV BY

YORK SOLUTION UNIT DRAWING
 MODEL: XTO-132x138 05/08/2024 01:22:28 PM UTC
 DESIGNATION: RTS-01
 PROJECT NAME: ENVISION 2 SC OUTDOOR UNITS

PIPING CONNECTIONS
 SHEET 5 OF 6 CONTRACT#: 4E-H40118-04
 UNIT TAG: **RTS-01, RTS-02, RTS-03, RTS-04, RTS-05, RTS-06**

ALL DIMENSIONS SHOWN IN: INCHES
 DRAWING SCALE: NTS
 DIMENSION TOLERANCES: UNIT (+/- 1/2"); PIPING (+/- 2")
 WEIGHT: 18409 (+/- 10%)
DRAWING NOT TO BE USED FOR CONSTRUCTION

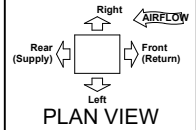

JCI NOTE: Not official curb drawings (for reference only). Curb submittal to be provided separately.

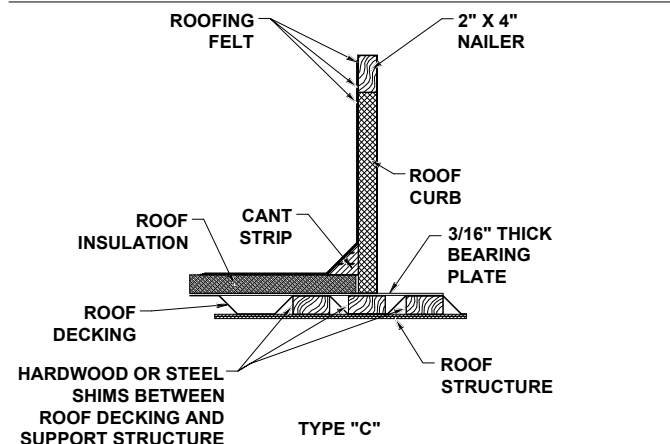
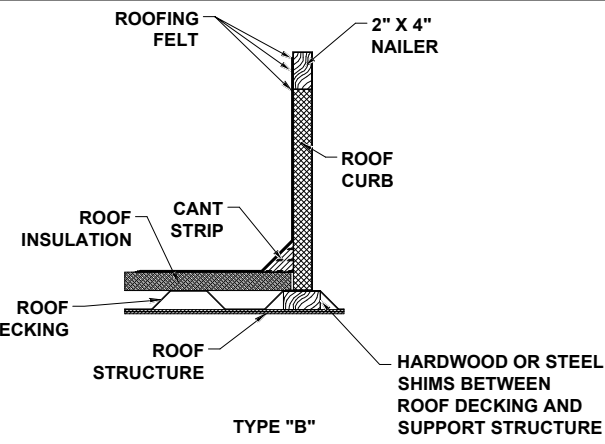
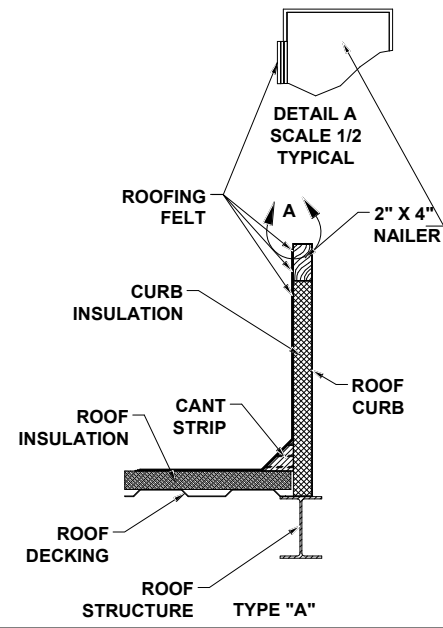

NOTES: 1. CERTAIN ITEMS MAY EXTEND BYOND CABINET DIMENSIONS. (ex. COIL CONNECTIONS, DOOR Handles, MOUNTING FEET, ETC.)
 2. ROOF CURB MUST BE INSTALLED SQUARE AND LEVEL.
 3. CROSS BRACES AS REQ'D: NO SPLICES OR CROSS BRACES WITHIN 10.00\"/>

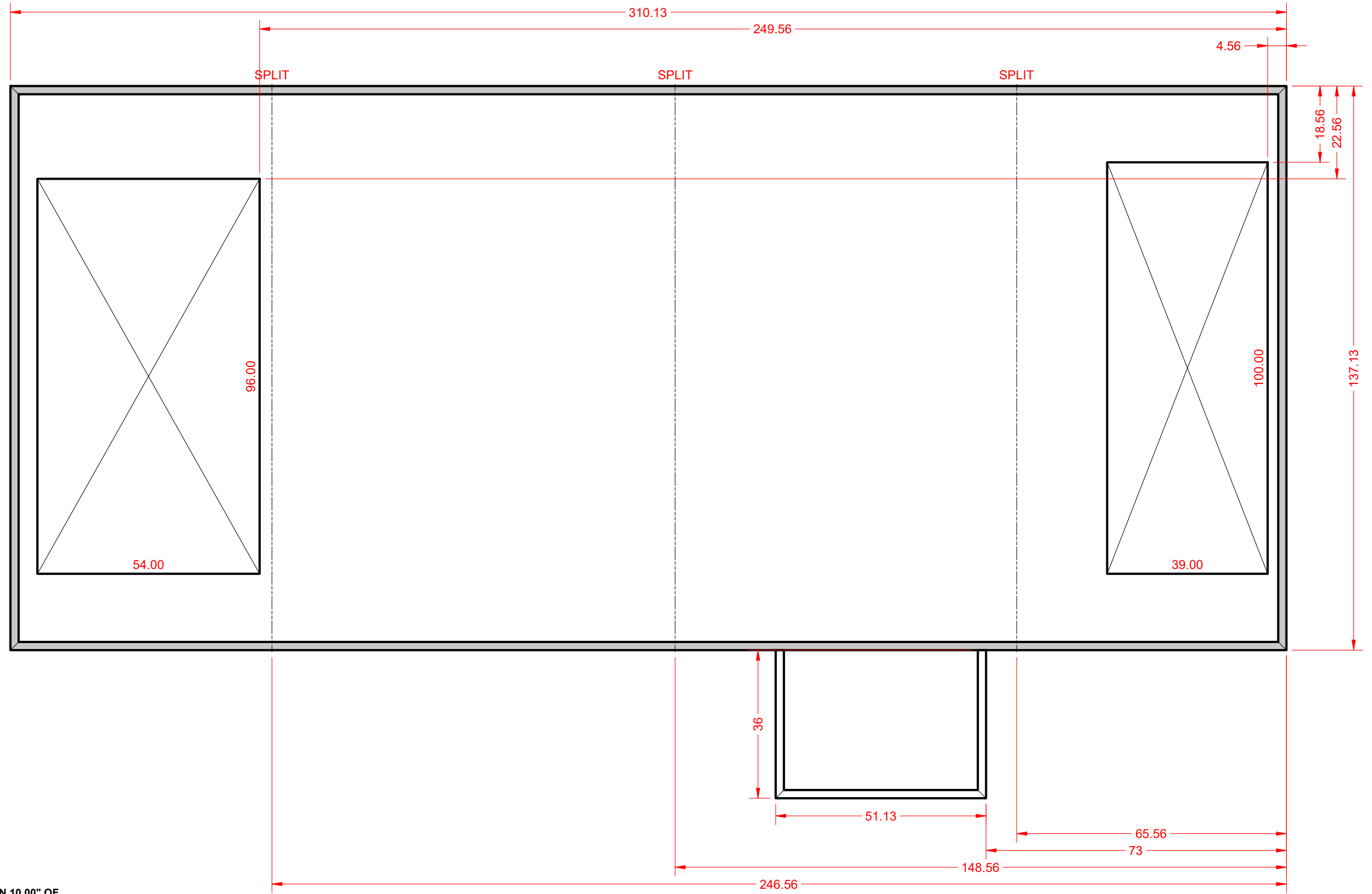

REV	DATE	REVISION CHANGE	REV BY

YORK SOLUTION UNIT DRAWING
 MODEL: XTO-132x138 05/08/2024 01:22:28 PM UTC
 DESIGNATION: RTS-01
 PROJECT NAME: ENVISION 2 SC OUTDOOR UNITS

ROOF CURB
 SHEET 6 OF 6 CONTRACT#: 4E-H40118-04
 UNIT TAG: **RTS-01, RTS-02, RTS-03, RTS-04, RTS-05, RTS-06**

ALL DIMENSIONS SHOWN IN: INCHES
 DRAWING SCALE: NTS
 DIMENSION TOLERANCES: UNIT (+/- 1/2"); PIPING (+/- 2")
 WEIGHT: 18409 (+/- 10%)
DRAWING NOT TO BE USED FOR CONSTRUCTION

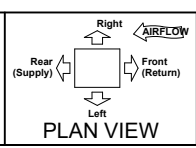



Wiring Diagrams

Product Type: Semi-Custom Air Handling Units

Unit Tags: Various

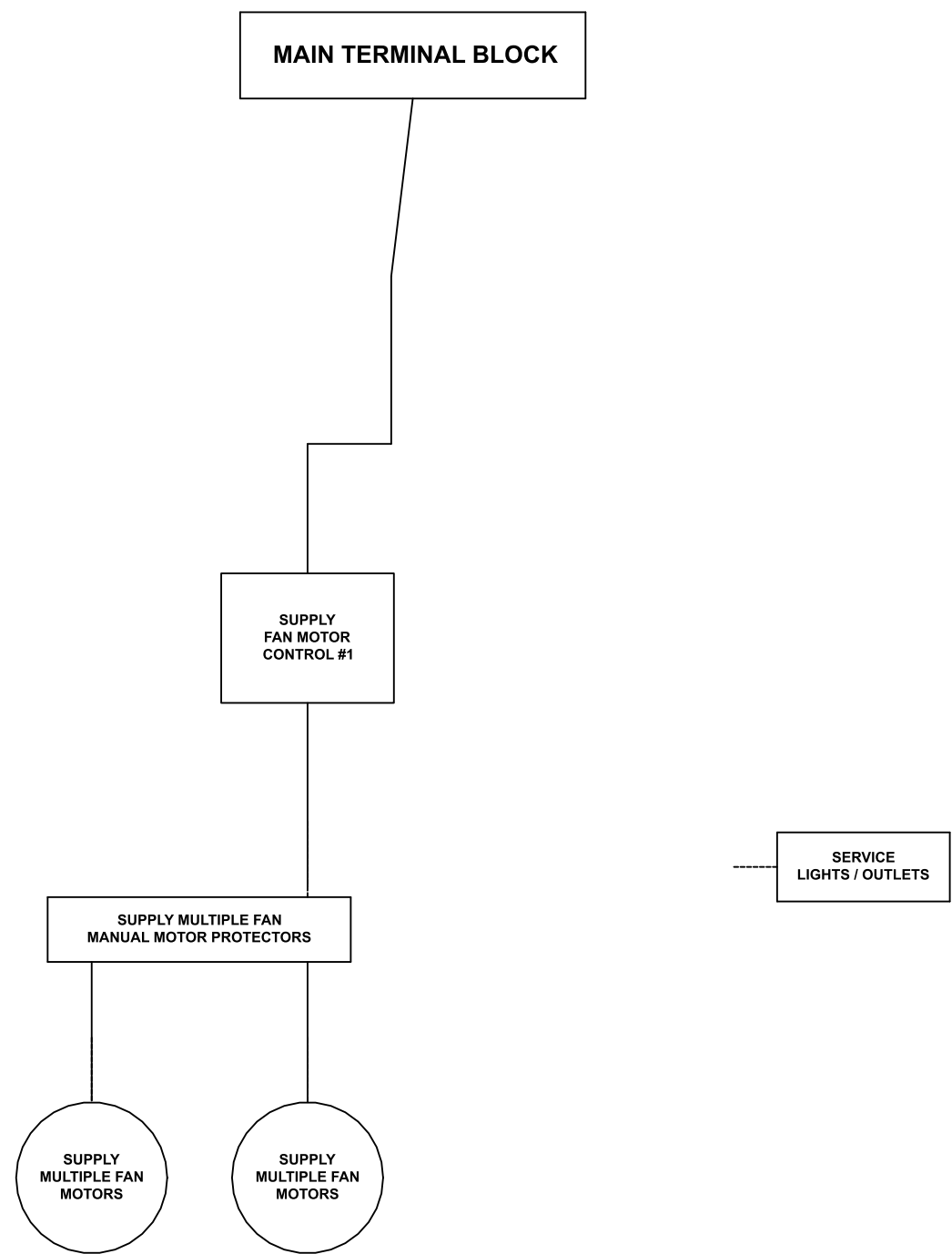

RTS 01-06

PRODUCT DRAWING
 AHU Field Wiring
 MODEL:
NOT FOR CONSTRUCTION

Project Name: Envision 2 SC Outdoor Units
 Location: ,
 Engineer:
 Contractor:
 For:

Sold To:
 Cust Purch Order#:
 Contract#: 4E-H40118-01
 UNIT
 TAG:

Date: 3/29/2024 5:58:02 PM (UTC)
 Form No.: 100.09-EG1
 Dwg. Lev.: 12/03
 Dwg. Scale: NTS

Serial Number:
 SQ Database Number:
 YORKworks Release:
 Dwg. Name:
 Dwg. Location:





VFD Information

Product Type: Semi-Custom Air Handling Units

Unit Tags: Various



AYK 580 Air-Modulator

ENGINEERING GUIDE



1 - 75HP / (4.6 to 273 Amps)	208 - 240VAC
1.5 - 150HP / (2.1 to 180 Amps)	380 - 480VAC
2 - 125HP / (2.7 to 125 Amps)	515 - 600VAC



JOHNSON CONTROLS PACKAGE CONFIGURATIONS

The following AYK580 JCI Drive configurations are available as standard product offerings:



Base Drive

"01" Configuration

- AYK580 VFD UL Type 1 / NEMA 1 / conduit box supplied as standard
- AYK580 HVAC advanced control panel supplied as standard
- 100K SCCR at 480 V w/ fast acting drive input fusing



Base Drive with Fused Disconnect

"PF" Configuration

- AYK580 VFD "01" Base Drive w/ fast acting drive input fusing belly box
- Available as standard:
 - UL Type 1 / Nema 1 indoor
 - UL Type 3R / Nema 3R outdoor
- Fused main disconnect with pad lockable handle
- 100K SCCR at 480 V



Base Drive with Bypass, VFD Isolation Service Switch, Main Fused Disconnect

"CF" Configuration



- AYK580 VFD available as standard UL Type 1 / Nema 1 indoor UL Type 3R / Nema 3R outdoor Supplied as standard
- Special note: Heater and thermostat included on all 3R units.
- Main J Type fused disconnect with pad lockable handle in the open position
- VFD input fast acting fused service disconnect
- Control power transformer
- Classic 2 contactor (wide range coil) mechanical bypass
- Class 10, 20, or 30 electronic overload relay for bypass circuit
- VFD/OFF/BYPASS (3 position) selector switch
- HAND/OFF/AUTO (3 position) selector switch for operation in bypass only. HOA in VFD mode through VFD control panel



Dimensions (continued)

Use the chart below to determine the overall dimensions based on HP, current, voltage, and package configuration.

TABLE 5 - AYK 580 FRAME SIZE CHART (NEMA 3R/UL TYPE 3R OUTDOOR)

HP	208/230 V			460 V			575 V		
	CUR-RENT	(PF)	(CF)	CUR-RENT	(PF)	(CF)	CUR-RENT	(PF)	(CF)
1	4.6	PX3R-1	CX3R-1	2.1	PX3R-1	CX3R-1	N/A	N/A	N/A
1.5	6.6	PX3R-1	CX3R-1	3	PX3R-1	CX3R-1	N/A	N/A	N/A
2	7.5	PX3R-1	CX3R-1	3.5	PX3R-1	CX3R-1	2.7	PX3R-2	CX3R-2
3	10.6	PX3R-1	CX3R-1	4.8	PX3R-1	CX3R-1	3.9	PX3R-2	CX3R-2
5	16.7	PX3R-1	CX3R-1	7.6	PX3R-1	CX3R-1	6.1	PX3R-2	CX3R-2
7.5	24.2	PX3R-2	CX3R-2	12	PX3R-1	CX3R-1	9	PX3R-2	CX3R-2
10	30.8	PX3R-2	CX3R-2	14	PX3R-2	CX3R-2	11	PX3R-2	CX3R-2
15	46.2	PX3R-3	CX3R-3	23	PX3R-2	CX3R-2	17	PX3R-2	CX3R-2
20	59.4	PX3R-3	CX3R-3	27	PX3R-3	CX3R-3	22	PX3R-3	CX3R-3
25	74.8	PX3R-4	CX3R-4	34	PX3R-3	CX3R-3	27	PX3R-3	CX3R-3
30	88	PX3R-4	CX3R-4	44	PX3R-3	CX3R-3	32	PX3R-4	CX3R-4
40	114	PX3R-4	CX3R-4	52	PX3R-4	CX3R-4	41	PX3R-4	CX3R-4
50	143	PX3R-6	CX3R-6	65	PX3R-4	CX3R-4	52	PX3R-4	CX3R-4
60	169	PX3R-6	CX3R-6	77	PX3R-4	CX3R-4	62	PX3R-4	CX3R-4
75	211	PX3R-6	CX3R-6	96	PX3R-4	CX3R-4	77	PX3R-6	CX3R-6
100	273	N/A	N/A	124	PX3R-5	CX3R-5	99	PX3R-6	CX3R-6
125	N/A	N/A	N/A	156	PX3R-6	CX3R-6	125	PX3R-6	CX3R-6
150	N/A	N/A	N/A	180	PX3R-6	CX3R-6	N/A	N/A	N/A

PF+B058 - Base drive with fused input disconnect switch

CF+B058 - Base drive with fused input disconnect, classic 2 contactor bypass, drive isolation input fast acting fused service disconnect switch

Note: When mounting drives side by side, allow 2 in. (50.8 mm) on each side to provide clearance for door swing and cooling.

Dimensions (continued)

Base drive with fused disconnect
(Pages to) AYK590-PF+B058 Nema 3R Option
 Enclosures 1 through 6. The following dimensions are for options PF+B058.

TABLE 6 - AYK580-PF+B058 NEMA 3R OPTION

UL (NEMA) TYPE 3R				DRIVE W/ MAIN INPUT FUSED DISCONNECT			
PACKAGE SIZE	DIMENSIONAL DRAWING NO.	ELECTRICAL DRAWING NO.	"DIM REF"	HEIGHT (H)	WIDTH (W)	DEPTH (D)	EST. WEIGHT
				IN	IN	IN	LB
Box 1	3AXD50000494781	3AXD50000490134	PX3R-1	22.427	15.158	14.359	49
Box 2	3AXD50000495030	3AXD50000490134	PX3R-2	28.432	15.158	14.359	64
Box 3	3AXD50000495146	3AXD50000490134	PX3R-3	35.103	18.520	14.359	151
Box 4	3AXD50000496563	3AXD50000490134	PX3R-4	45.568	18.52	16.54	214
Box 5	3AXD50000495221	3AXD50000490134	PX3R-5	49.682	21.77	18.54	273
Box 6	3AXD50000496747	3AXD50000490134	PX3R-6	56.755	21.935	21.537	392

Base drive with main input fused disconnect, classic two contactor bypass and drive isolation fast acting fused service switch
(Pages to) AYK580-CF+B058 Nema 3R Option
 Enclosures 1 through 6. The following dimensions are for Options CF+B058.

UL (NEMA) TYPE 3R				DRIVE W/ MAIN INPUT FUSED DISCONNECT, BYPASS & FUSED SERVICE SWITCH			
PACKAGE SIZE	DIMENSIONAL DRAWING NO.	ELECTRICAL DRAWING NO.	"DIM REF"	HEIGHT (H)	WIDTH (W)	DEPTH (D)	EST. WEIGHT
				IN	IN	IN	LB
Box 1	3AXD50000495078	3AXD50000489268	CX3R-1	20.507	18.000	17.359	70
Box 2	3AXD50000495597	3AXD50000489268	CX3R-2	27.507	20.158	17.359	84
Box 3	3AXD50000496419	3AXD50000489268	CX3R-3	32.731	22.52	17.359	175
Box 4	3AXD50000496938	3AXD50000489268	CX3R-4	45.49	28.52	18.54	273
Box 5	3AXD50000496334	3AXD50000489268	CX3R-5	46.181	32.52	22.462	394
Box 6	3AXD50000499632	3AXD50000489268	CX3R-6	53.177	32.52	22.462	485

Dimensions (continued)

Drawing #: 3AXD50000494781

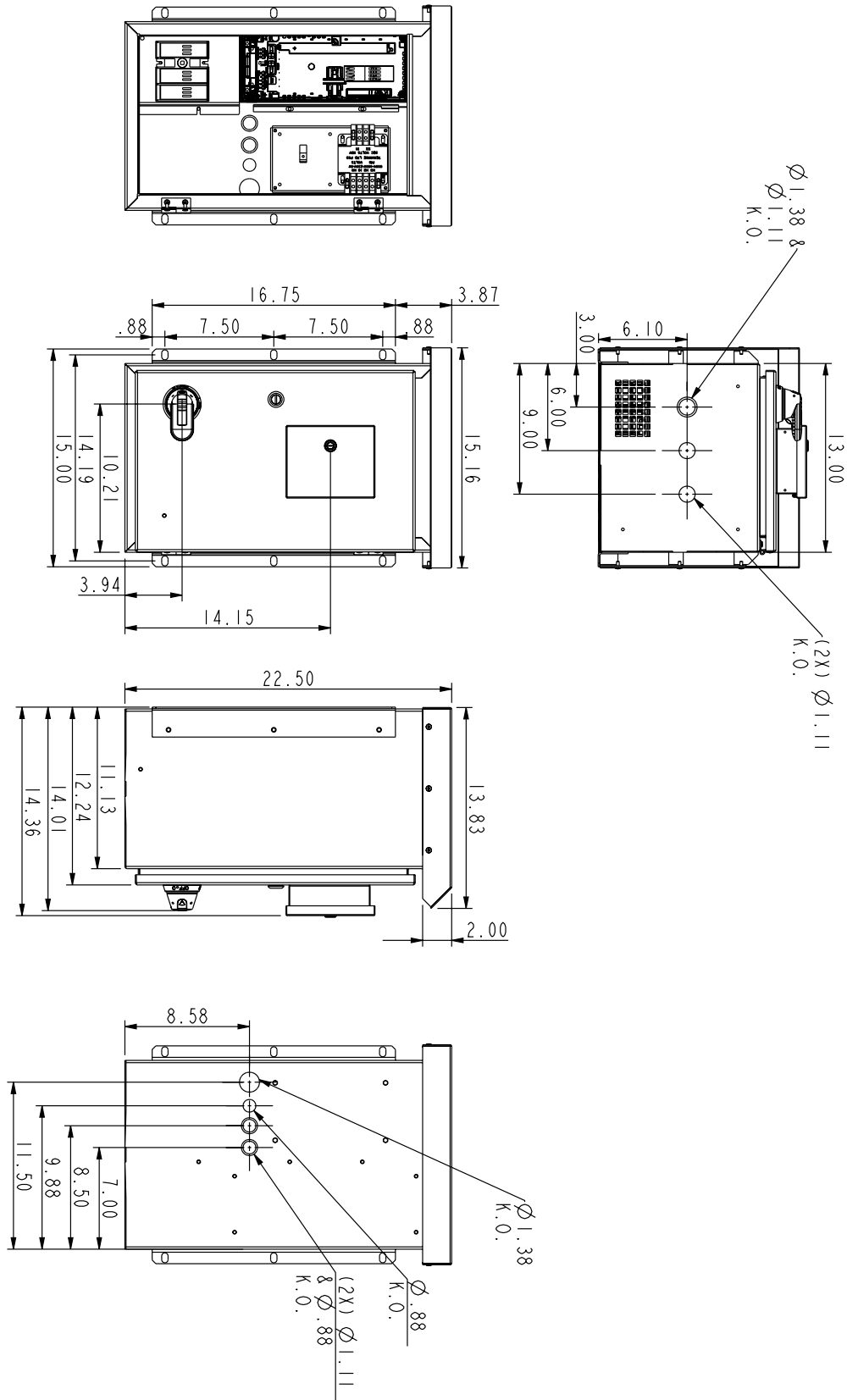

FIGURE 31 - 3R NONBYPASS BOX 1

Dimensions (continued)

Drawing #: 3AXD50000495030

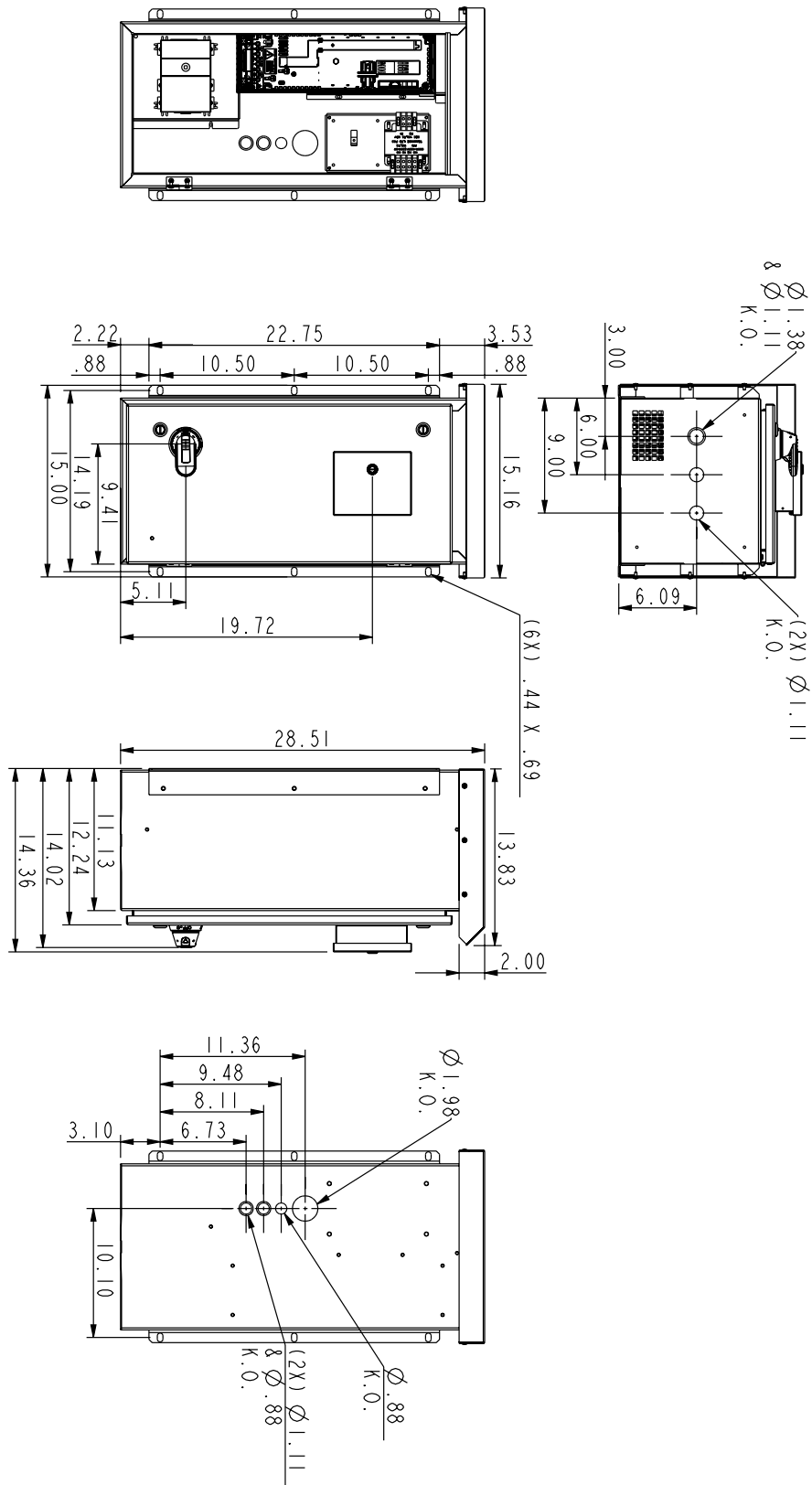

FIGURE 32 - 3R NONBYPASS BOX 2

Dimensions (continued)

Drawing #: 3AXD50000495146

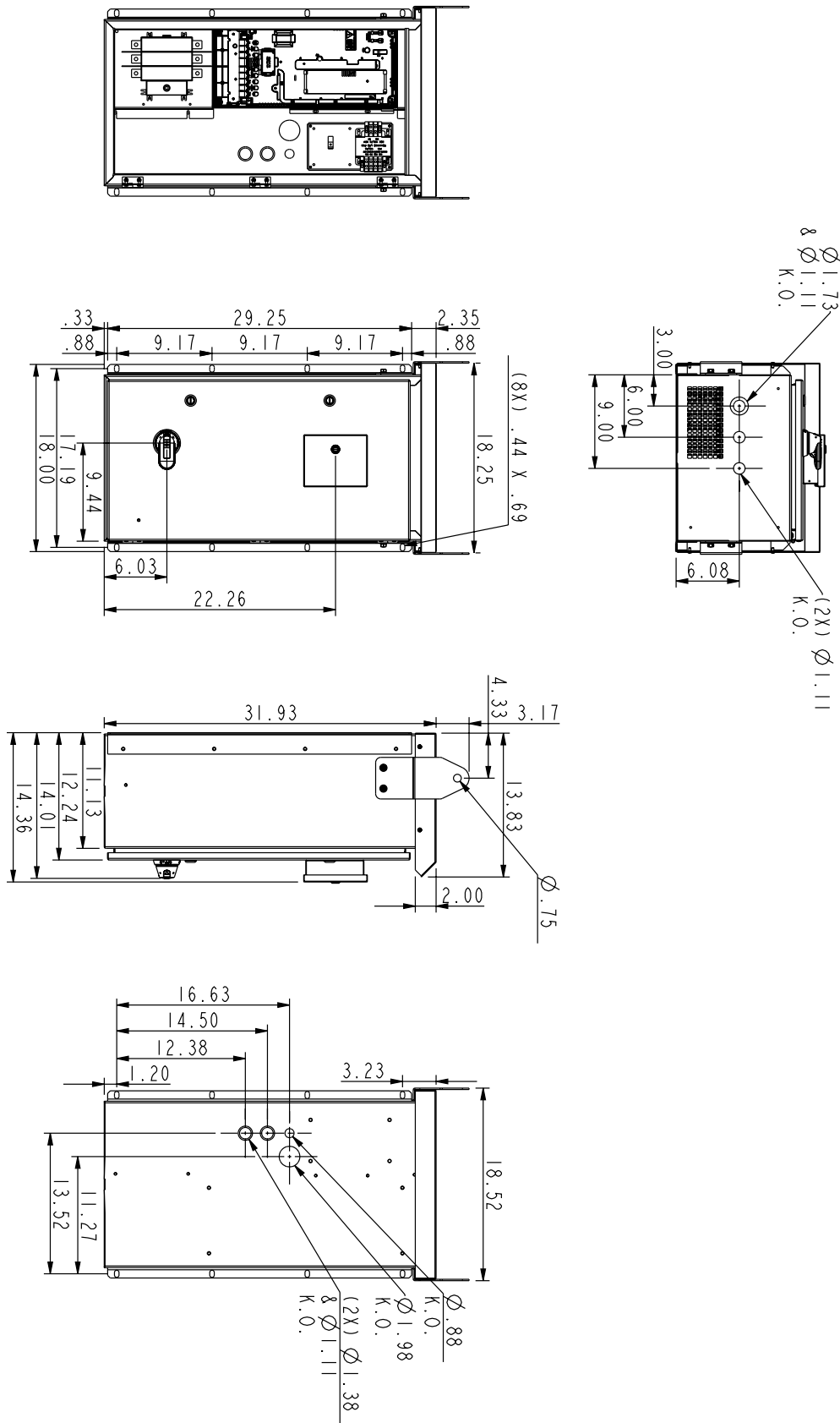

FIGURE 33 - 3R NONBYPASS BOX 3

Dimensions (continued)

Drawing #: 3AXD50000496563

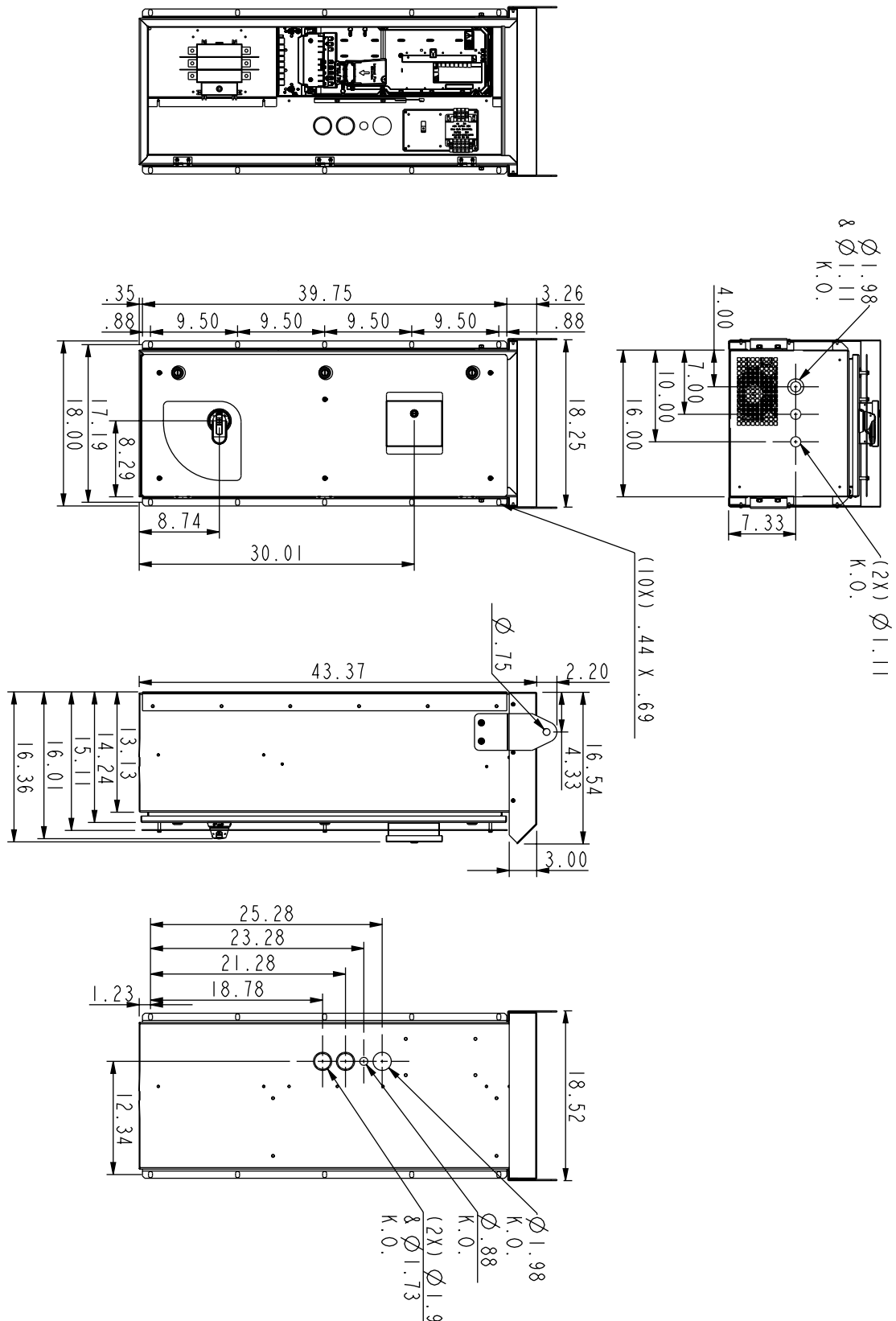

FIGURE 34 - 3R NONBYPASS BOX 4

Dimensions (continued)

Drawing #: 3AXD50000495221

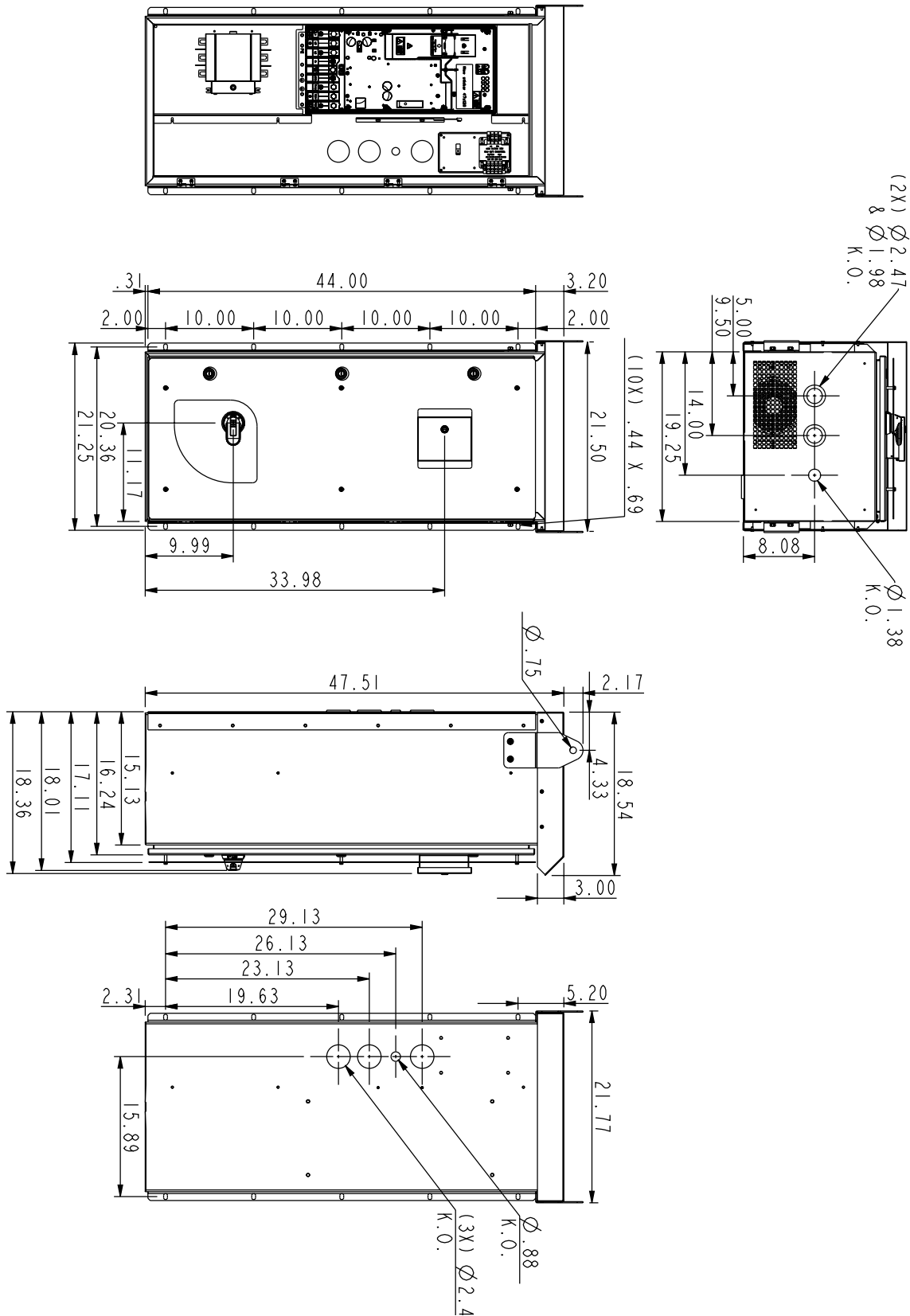

FIGURE 35 - 3R NONBYPASS BOX 5

Dimensions (continued)

Drawing #: 3AXD50000496747

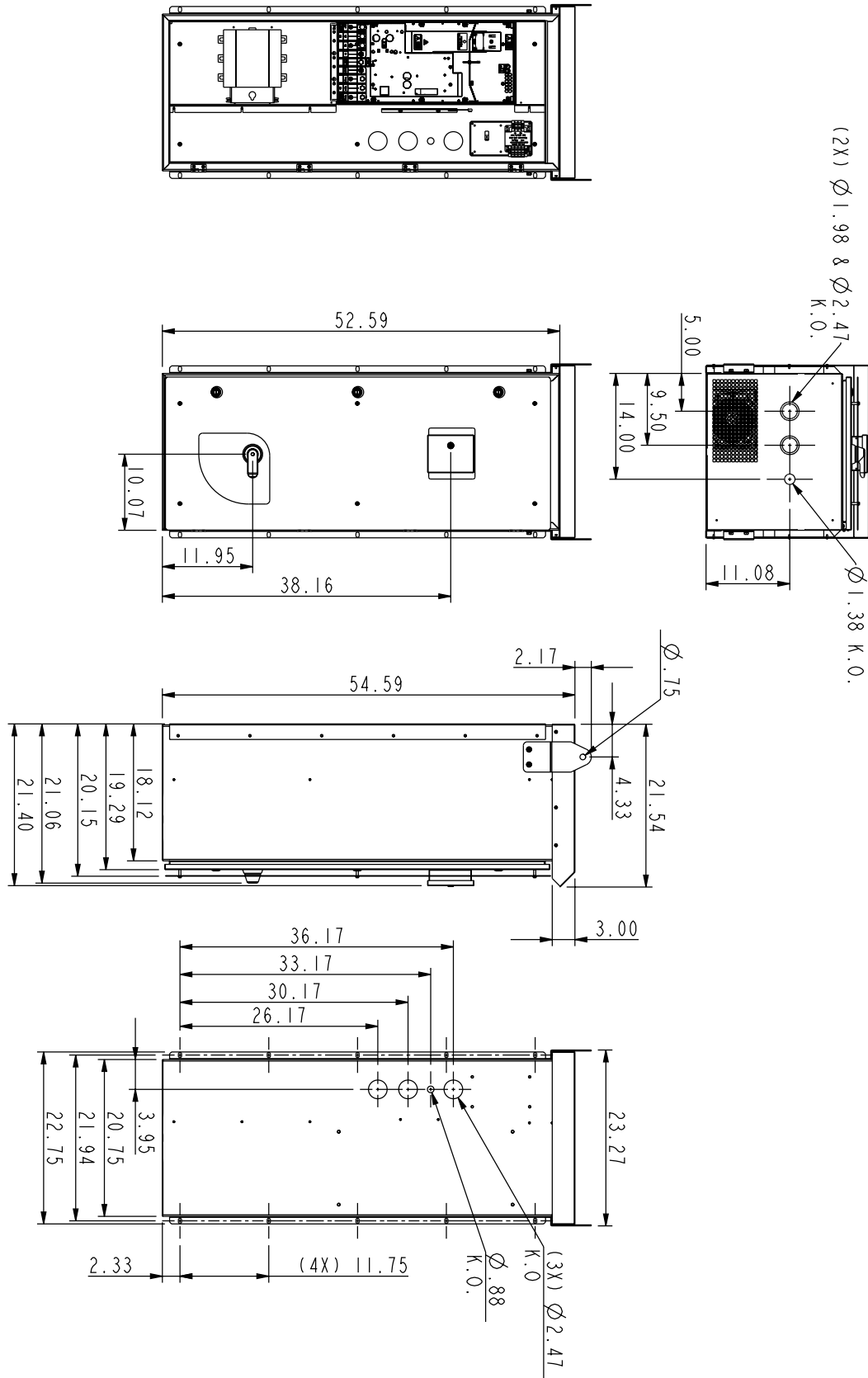

FIGURE 36 - 3R NONBYPASS BOX 6

TABLE 7 - PERFORMANCE DATA 200 - 240 VAC

AYK JCI Drive	Special Note: Plus Code +P940 = Base Drive Less Cover and Less Conduit Box / IP20							
ABB Model	AYK 580-01	AYK 580-01	AYK 580-01	AYK 580-01	AYK 580-01	AYK 580-01	AYK 580-01	AYK 580-01
Series	-04A6-2	-06A6-2	-07A5-2	-10A6-2	-017A-2	-024A-2	-031A-2	-046A-2
Motor Horsepower	1	1.5	2	3	5	7.5	10	15
Motor KW	0.7	1.1	1.5	2.2	3.7	5.6	7.5	11.2
Frame Size	R1	R1	R1	R1	R1	R2	R2	R3
Output Current Amps @ 40°C	4.6	6.6	7.5	10.6	16.7	24.8	30.8	46.2
Overload Current Rating	110% for 1 minute every 10 minutes							
Max Output Voltage	3 Phase 0 volts up to input voltage max.							
Rated Input Voltage	3 Phase 208/240 VAC +10%/-15% 48/63Hz +/- 3%							
Rated Input Current Amps @ 40°C (Use on Unit ID Nameplate)	4.6	6.6	7.5	10.6	16.7	24	30.8	46.2
Recommended Class T Fuse Size (Amps)	15	15	15	15	30	40	40	80
Maximum Power Cable Size AWG	10	10	10	10	10	6	6	2
Heat Loss in watts 100 % load	45	55	66	84	133	174	228	322
Efficiency (%) min.	Approximately 98% at nominal load							
Environment								
Ambient Temperature	-15 to +50 °C (5 to 122 °F): No frost allowed / Output derated above +40 °C (104 °F)							
Storage Temperature	-40°C to 70°C -40 - 158° F							
Humidity	5 to 95% No condensation allowed Maximum relative humidity is 60% in the presence of corrosive gasses							
Altitude	MAX 3,300 feet without de-rate. 1% derate for each 330 feet above 3,300 up to 6,600' / Above 6,600' Contact Tech Support for additional derating (Max Altitude to 13,123' with Derate)							
Enclosure	Nema 1 Fan Cooled / with Conduit Box Included as Standard							
Weight kg approximate	4.60	4.60	4.60	4.60	4.60	6.60	6.60	11.80
Weight Lbs approximate	10.10	10.10	10.10	10.10	10.10	14.60	14.60	26.00
Input Frequency	48-63 Hz							
Imbalance	maximum +/- 3% of nominal phase to phase input voltage							
Fundamental Power Factor (cos phi)	0.98 at nominal load							
Frequency Resolution	0.01Hz							
Maximum motor cable length	100 M (R1); 200 M (R2); 300 M (R3-R9) max without output fitters							
Heat Loss in BTU/Hr 100 % load	155	187	224	288	454	593	777	1100
Air Flow m3/h	43	43	43	43	43	101	101	179
Air Flow ft3/min	25	25	25	25	25	59	59	105
Sinusoidal Vibration (IEC 60068-2-6)	Mechanical conditions: IEC 60068-2 , 2....13.2Hz 1mm (0.04in) , 13.2...100Hz 7m/s2 (23 ft/s2)							
Output Current Derating								
Temperature 1% per degree C above 40°C IE: 50°C=output* 0.90	-15 to +50 °C (5 to 122 °F): No frost allowed / Output derated above +40 °C (104 °F)							
Altitude: 1% of output for every 330 feet above 3,300 feet	MAX 3,300 feet without de-rate. 1% derate for each 330 feet above 3,300 up to 6,600' / Above 6,600' Contact Tech Support for additional derating (Max Altitude to 13,123' with Derate)							
Single Phase supply for 208-240v drives derate output by 50%	Rule of THUMB for Single Phase supply for 208-240v drives derate output by 50% / Need Actual 3Phase Motor Data to Determine Drive Size / Also Refer to User Manual for any additional concerns it any							
Switching Frequency: 2, 4, 8 or 12 kHz See User Manual for Derate	Switching Frequency: 2, 4, 8 or 12 kHz Please see User Manual for Proper Derates at Carrier Frequencies above 4KHz. / Automatic fold back in case of overload							

Single phase 208-240 VAC input available on base drive only. Output will be at 3 phase to motor. Bypass will not work on single phase input. Consult Johnson Controls Marketing for single phase applications
Do not use aluminium cable with frame sizes R1...R4

Performance Data (continued)

TABLE 17 - PERFORMANCE DATA 200 - 240 VAC (CONT'D)

AYK JCI Drive	Special Note: Plus Code +P940 = Base Drive Less Cover and Less Conduit Box / IP20							
ABB Model	AYK 580-01	AYK 580-01	AYK 580-01	AYK 580-01	AYK 580-01	AYK 580-01	AYK 580-01	AYK 580-01
Series	-059A-2	-075A-2	-088A-2	-114A-2	-143A-2	-169A-2	-211A-2	-273A-2
Motor Horsepower	20	25	30	40	50	60	75	100
Motor KW	14.9	18.6	22.4	29.8	37.3	44.7	55.9	74.6
Frame Size	R3	R4	R5	R5	R6	R7	R7	R8
Output Current Amps @ 40°C	59.4	74.8	88	114	143	169	211	273
Overload Current Rating	110% for 1 minute every 10 minutes							
Max Output Voltage	3 Phase 0 volts up to input voltage max.							
Rated Input Voltage	3 Phase 208/240 VAC +10%/-15% 48/63Hz +/- 3%							
Rated Input Current Amps @ 40°C (Use on Unit ID Nameplate)	59.4	74.8	88	114	143	169	211	273
Recommended Class T Fuse Size (Amps)	80	100	150	150	200	250	300	400
Maximum Power Cable Size AWG	2	1	2/0	2/0	300MCM	500MCM	500MCM	(2)300MCM
Heat Loss in watts 100 % load	430	525	619	835	1035	1251	1251	2061
Efficiency (%) min.	Approximately 98% at nominal load							
Environment								
Ambient Temperature	-15 to +50 °C (5 to 122 °F): No frost allowed / Output derated above +40 °C (104 °F)							
Storage Temperature	-40°C to 70°C -40 - 158' F							
Humidity	5 to 95% No condensation allowed Maximum relative humidity is 60% in the presence of corrosive gasses							
Altitude	MAX 3,300 feet without de-rate. 1% derate for each 330 feet above 3,300 up to 6,600' / Above 6,600' Contact Tech Support for additional derating (Max Altitude to 13,123' with Derate)							
Enclosure	Nema 1 Fan Cooled / with Conduit Box Included as Standard							
Weight kg approximate	11.80	19.00	28.30	28.30	42.40	54.00	54.00	69.00
Weight Lbs approximate	26.00	41.90	62.40	62.40	93.50	119.10	119.10	152.20
Input Frequency	48-63 Hz							
Imbalance	maximum +/- 3% of nominal phase to phase input voltage							
Fundamental Power Factor (cos phi)	0.98 at nominal load							
Frequency Resolution	0.01Hz							
Maximum motor cable length	100 M (R1); 200 M (R2); 300 M (R3-R9) max without output fitters							
Heat Loss in BTU/Hr 100 % load	1469	1791	2114	2852	3535	4272	5194	7039
Air Flow m3/h	179	288	139	139	435	450	450	550
Air Flow ft3/min	105	170	82	82	256	265	265	324
Sinusoidal Vibration (IEC 60068-2-6)	Mechanical conditions: IEC 60068-2, 2....13.2Hz 1mm (0.04in) , 13.2...100Hz 7m/s2 (23 ft/s2)							
Output Current Derating								
Temperature 1% per degree C above 40°C IE: 50°C=output* 0.90	-15 to +50 °C (5 to 122 °F): No frost allowed / Output derated above +40 °C (104 °F)							
Altitude: 1% of output for every 330 feet above 3,300 feet	MAX 3,300 feet without de-rate. 1% derate for each 330 feet above 3,300 up to 6,600' / Above 6,600' Contact Tech Support for additional derating (Max Altitude to 13,123' with Derate)							
Single Phase supply for 208-240v drives derate output by 50%	Rule of THUMB for Single Phase supply for 208-240v drives derate output by 50% / Need Actual 3Phase Motor Data to Determine Drive Size / Also Refer to User Manual for any additional concerns it any							
Switching Frequency: 2, 4, 8 or 12 kHz See User Manual for Derate	Switching Frequency: 2, 4, 8 or 12 kHz Please see User Manual for Proper Derates at Carrier Frequencies above 4KHz. / Automatic fold back in case of overload							

Single phase 208-240 VAC input available on base drive only. Output will be at 3 phase to motor. Bypass will not work on single phase input. Consult Johnson Controls Marketing for single phase applications
Do not use aluminium cable with drame sizes R1...R4

Performance Data (continued)

FORM 100.42-EG1 (920)

TABLE 8 - PERFORMANCE DATA 380-480 VAC

AYK JCI Drive	Special Note: Plus Code +P940 = Base Drive Less Cover and Less Conduit Box / IP20							
ABB Model	AYK 580-01	AYK 580-01	AYK 580-01	AYK 580-01	AYK 580-01	AYK 580-01	AYK 580-01	AYK 580-01
Series	-02A1-4	-03A0-4	-03A5-4	-04A8-4	-07A6-4	-012A-4	-014A-4	-023A-4
Motor Horsepower	1	1.5	2	3	5	7.5	10	15
Motor KW	0.7	1.1	1.5	2.2	3.7	5.6	7.5	11.2
Frame Size	R1	R1	R1	R1	R1	R1	R2	R2
Output Current Amps @ 40°C	2.1	3	3.5	4.8	7.6	12	14	23
Overload Current Rating	110% for 1 minute every 10 minutes							
Max Output Voltage	3 Phase 0 volts up to input voltage max.							
Rated Input Voltage	380/400/415/440/460/480 +10% -15% VAC 3 phase 48/63Hz +/- 3%							
Rated Input Current Amps @ 40°C (Use on Unit ID Nameplate)	2.1	3	3.5	4.8	7.6	12	14	23
Recommended Class T Fuse Size (Amps)	15	15	15	15	15	15	30	30
Maximum Power Cable Size AWG	10	10	10	10	10	10	6	6
Heat Loss in watts 100 % load	45	55	66	84	133	174	228	322
Efficiency (%) min.	Approximately 98% at nominal load							
Environment								
Ambient Temperature	-15 to +50 °C (5 to 122 °F): No frost allowed / Output derated above +40 °C (104 °F)							
Storage Temperature	-40°C to 70°C -40 - 158° F							
Humidity	5 to 95% No condensation allowed Maximum relative humidity is 60% in the presence of corrosive gasses							
Altitude	MAX 3,300 feet without de-rate. 1% derate for each 330 feet above 3,300 up to 6,600' / Above 6,600' Contact Tech Support for additional derating (Max Altitude to 13,123' with Derate)							
Enclosure	Nema 1 Fan Cooled / with Conduit Box Included as Standard							
Weight kg approximate	4.60	4.60	4.60	4.60	4.60	4.60	6.60	6.60
Weight Lbs approximate	10.10	10.10	10.10	10.10	10.10	10.10	14.60	14.60
Input Frequency	48-63 Hz							
Imbalance	maximum +/- 3% of nominal phase to phase input voltage							
Fundamental Power Factor (cos phi)	0.98 at nominal load							
Frequency Resolution	0.01Hz							
Maximum motor cable length	100 M (R1); 200 M (R2); 300 M (R3-R9) max without output filters							
Heat Loss in BTU/Hr 100 % load	155	187	224	288	454	593	777	1100
Air Flow m3/h	43	43	43	43	43	43	101	101
Air Flow ft3/min	25	25	25	25	25	25	59	59
Sinusoidal Vibration (IEC 60068-2-6)	Mechanical conditions: IEC 60068-2 , 2....13.2Hz 1mm (0.04in) , 13.2...100Hz 7m/s2 (23 ft/s2)							
Output Current Derating								
Temperature 1% per degree C above 40°C IE: 50°C=output* 0.90	-15 to +50 °C (5 to 122 °F): No frost allowed / Output derated above +40 °C (104 °F)							
Altitude: 1% of output for every 330 feet above 3,300 feet	MAX 3,300 feet without de-rate. 1% derate for each 330 feet above 3,300 up to 6,600' / Above 6,600' Contact Tech Support for additional derating (Max Altitude to 13,123' with Derate)							
Switching Frequency: 2, 4, 8 or 12 kHz. See User Manual for Derate	Switching Frequency: 2, 4, 8 or 12 kHz Please see User Manual for Proper Derates at Carrier Frequencies above 4KHz. / Automatic fold back in case of overload							

1% derate for each 330 feet above 3,300

Performance Data (continued)

FORM 100.42-EG1 (920)

TABLE 8 - PERFORMANCE DATA 380-480 VAC (CONT'D)

AYK JCI Drive	Special Note: Plus Code +P940 = Base Drive Less Cover and Less Conduit Box / IP20							
ABB Model	AYK 580-01	AYK 580-01	AYK 580-01	AYK 580-01	AYK 580-01	AYK 580-01	AYK 580-01	AYK 580-01
Series	-027A-4	-034A-4	-044A-4	-052A-4	-065A-4	-077A-4	-096A-4	-124A-4
Motor Horsepower	20	25	30	40	50	60	75	100
Motor KW	14.9	18.6	22.4	29.8	37.3	44.7	55.9	74.6
Frame Size	R3	R3	R3	R4	R4	R4	R5	R6
Output Current Amps @ 40°C	27	34	44	52	65	77	96	124
Overload Current Rating	110% for 1 minute every 10 minutes							
Max Output Voltage	3 Phase 0 volts up to input voltage max.							
Rated Input Voltage	380/400/415/440/460/480 +10% -15% VAC 3 phase 48/63Hz +/- 3%							
Rated Input Current Amps @ 40°C (Use on Unit ID Nameplate)	27	34	44	52	62	77	106	124
Recommended Class T Fuse Size (Amps)	40	60	60	80	100	100	150	200
Maximum Power Cable Size AWG	2	2	2	1	1	1	2/0	300MCM
Heat Loss in watts 100 % load	430	525	619	835	1024	1240	1510	1476
Efficiency (%) min.	Approximately 98% at nominal load							
Environment								
Ambient Temperature	-15 to +50 °C (5 to 122 °F): No frost allowed / Output derated above +40 °C (104 °F)							
Storage Temperature	-40°C to 70°C -40 - 158' F							
Humidity	5 to 95% No condensation allowed Maximum relative humidity is 60% in the presence of corrosive gasses							
Altitude	MAX 3,300 feet without de-rate. 1% derate for each 330 feet above 3,300 up to 6,600' / Above 6,600' Contact Tech Support for additional derating (Max Altitude to 13,123' with Derate)							
Enclosure	Nema 1 Fan Cooled / with Conduit Box Included as Standard							
Weight kg approximate	11.80	11.80	11.80	19.00	19.00	19.00	28.30	42.40
Weight Lbs approximate	26.00	26.00	26.00	41.90	41.90	41.90	62.40	93.50
Input Frequency	48-63 Hz							
Imbalance	maximum +/- 3% of nominal phase to phase input voltage							
Fundamental Power Factor (cos phi)	0.98 at nominal load							
Frequency Resolution	0.01Hz							
Maximum motor cable length	100 M (R1); 200 M (R2); 300 M (R3-R9) max without output filter							
Heat Loss in BTU/Hr 100 % load	1469	1791	2114	2852	3497	4235	5157	5041
Air Flow m3/h	179	179	179	134	134	288	139	435
Air Flow ft3/min	105	105	105	79	79	79	82	256
Sinusoidal Vibration (IEC 60068-2-6)	Mechanical conditions: IEC 60068-2 , 2....13.2Hz 1mm (0.04in) , 13.2...100Hz 7m/s2 (23 ft/s2)							
Output Current Derating								
Temperature 1% per degree C above 40°C IE: 50°C=output* 0.90	-15 to +50 °C (5 to 122 °F): No frost allowed / Output derated above +40 °C (104 °F)							
Altitude: 1% of output for every 330 feet above 3,300 feet	MAX 3,300 feet without de-rate. 1% derate for each 330 feet above 3,300 up to 6,600' / Above 6,600' Contact Tech Support for additional derating (Max Altitude to 13,123' with Derate)							
Switching Frequency: 2, 4, 8 or 12 kHz. See User Manual for Derate	Switching Frequency: 2, 4, 8 or 12 kHz Please see User Manual for Proper Derates at Carrier Frequencies above 4KHz. / Automatic fold back in case of overload							

1% derate for each 330 feet above 3,300

Performance Data (continued)

TABLE 8 - PERFORMANCE DATA 380-480 VAC (CONT'D)

AYK JCI Drive	Special Note: Plus Code +P940 = Base Drive Less Cover and Less Conduit Box / IP20					
ABB Model	AYK 580-01	AYK 580-01	AYK 580-01	AYK 580-01	AYK 580-01	AYK 580-01
Series	-156A-4	-180A-4	-240A-4	-302A-4	-361A-4	-414A-4
Motor Horsepower	125	150	200	250	300	350
Motor KW	93.2	111.9	149.1	186.4	223.7	261.0
Frame Size	R7	R7	R8	R9	R9	R9
Output Current Amps @ 40°C	156	180	240	302	361	414
Overload Current Rating	110% for 1 minute every 10 minutes					
Max Output Voltage	3 Phase 0 volts up to input voltage max.					
Rated Input Voltage	380/400/415/440/460/480 +10% -15% VAC 3 phase 48/63Hz +/- 3%					
Rated Input Current Amps @ 40°C (Use on Unit ID Nameplate)	156	180	240	302	361	414
Recommended Class T Fuse Size (Amps)	225	300	350	500	500	600
Maximum Power Cable Size AWG	500MCM	500MCM	(2) 300MCM	(2) 500MCM	(2) 500MCM	(2) 500MCM
Heat Loss in watts 100 % load	1976	2346	3336	4836	4836	6036
Efficiency (%) min.	Approximately 98% at nominal load					
Environment						
Ambient Temperature	-15 to +50 °C (5 to 122 °F): No frost allowed / Output derated above +40 °C (104 °F)					
Storage Temperature	-40°C to 70°C -40 - 158' F					
Humidity	5 to 95% No condensation allowed Maximum relative humidity is 60% in the presence of corrosive gasses					
Altitude	MAX 3,300 feet without de-rate. 1% derate for each 330 feet above 3,300 up to 6,600' / Above 6,600' Contact Tech Support for additional derating (Max Altitude to 13,123' with Derate)					
Enclosure	Nema 1 Fan Cooled / with Conduit Box Included as Standard					
Weight kg approximate	54.00	54.00	69.00	97.00	97.00	97.00
Weight Lbs approximate	119.10	119.10	152.20	213.90	213.90	213.90
Input Frequency	48-63 Hz					
Imbalance	maximum +/- 3% of nominal phase to phase input voltage					
Fundamental Power Factor (cos phi)	0.98 at nominal load					
Frequency Resolution	0.01Hz					
Maximum motor cable length	100 M (R1); 200 M (R2); 300 M (R3-R9) max without output filter					
Heat Loss in BTU/Hr 100 % load	6748	8012	11393	16516	16515	20614
Air Flow m3/h	450	450	550	1150	1150	1150
Air Flow ft3/min	265	265	324	324	677	677
Sinusoidal Vibration (IEC 60068-2-6)	Mechanical conditions: IEC 60068-2 , 2...13.2Hz 1mm (0.04in) , 13.2...100Hz 7m/s2 (23 ft/s2)					
Output Current Derating						
Temperature 1% per degree C above 40°C IE: 50°C=output* 0.90	-15 to +50 °C (5 to 122 °F): No frost allowed / Output derated above +40 °C (104 °F)					
Altitude: 1% of output for every 330 feet above 3,300 feet	MAX 3,300 feet without de-rate. 1% derate for each 330 feet above 3,300 up to 6,600' / Above 6,600' Contact Tech Support for additional derating (Max Altitude to 13,123' with Derate)					
Switching Frequency: 2, 4, 8 or 12 kHz. See User Manual for Derate	Switching Frequency: 2, 4, 8 or 12 kHz Please see User Manual for Proper Derates at Carrier Frequencies above 4KHz. / Automatic fold back in case of overload					

1% derate for each 330 feet above 3,300

Performance Data (continued)

TABLE 9 - PERFORMANCE DATA 50-600 VAC

AYK JCI Drive	Special Note: Plus Code +P940 = Base Drive Less Cover and Less Conduit Box / IP20								
ABB Model	AYK 580-01	AYK 580-01	AYK 580-01	AYK 580-01	AYK 580-01	AYK 580-01	AYK 580-01	AYK 580-01	AYK 580-01
Series	-02A7-6	-03A9-6	-06A1-6	-09A0-6	-011A-6	-017A-6	-022A-6	-027A-6	-027A-6
Motor Horsepower	2	3	5	7.5	10	15	20	25	25
Motor KW	1.5	2.2	3.7	5.6	7.5	11.2	14.9	18.7	18.7
Frame Size	R2	R2	R2	R2	R2	R2	R3	R3	R3
Output Current Amps @ 40°C	2.7	3.9	6.1	9	11	17	22	27	27
Overload Current Rating	110% for 1 minute every 10 minutes								
Max Output Voltage	3 Phase 0 volts up to input voltage max.								
Rated Input Voltage	500/525/575/600 +10% -15% VAC 3 phase 48/63Hz +/- 3%								
Rated Input Current Amps @ 40°C (Use on Unit ID Nameplate)	2.7	3.9	6.1	9	11	17	22	27	27
Recommended Class T Fuse Size (Amps)	15	15	15	15	15	30	40	40	40
Maximum Power Cable Size AWG	6	6	6	6	6	6	2	2	2
Heat Loss in watts 100 % load	66	84	133	174	228	322	430	525	525
Efficiency (%) min.	Approximately 98% at nominal load								
Environment									
Ambient Temperature	-15 to +50 °C (5 to 122 °F): No frost allowed / Output derated above +40 °C (104 °F)								
Storage Temperature	-40°C to 70°C -40 - 158' F								
Humidity	5 to 95% No condensation allowed Maximum relative humidity is 60% in the presence of corrosive gasses								
Altitude	MAX 3,300 feet without de-rate. 1% derate for each 330 feet above 3,300 up to 6,600' / Above 6,600' Contact Tech Support for additional derating (Max Altitude to 13,123' with Derate)								
Enclosure	Nema 1 Fan Cooled / with Conduit Box Included as Standard								
Weight kg approximate	6.60	6.60	6.60	6.60	6.60	6.60	11.80	11.80	11.80
Weight Lbs approximate	14.60	14.60	14.60	14.60	14.60	14.60	26.00	26.00	26.00
Input Frequency	48-63 Hz								
Imbalance	maximum +/- 3% of nominal phase to phase input voltage								
Fundamental Power Factor (cos phi)	0.98 at nominal load								
Frequency Resolution	0.01Hz								
Maximum motor cable length	100 M (R1); 200 M (R2); 300 M (R3-R9) max without output filterers								
Heat Loss in BTU/Hr 100 % load	224	288	454	593	777	1100	1469	1791	1791
Air Flow m3/h	101	101	101	101	101	101	179	179	179
Air Flow ft3/min	59	59	59	59	59	59	105	105	105
Sinusoidal Vibration (IEC 60068-2-6)	Mechanical conditions: IEC 60068-2, 2....13.2Hz 1mm (0.04in) , 13.2...100Hz 7m/s2 (23 ft/s2)								
Output Current Derating									
Temperature 1% per degree C above 40°C IE: 50°C=output* 0.90	-15 to +50 °C (5 to 122 °F): No frost allowed / Output derated above +40 °C (104 °F)								
Altitude: 1% of output for every 330 feet above 3,300 feet	MAX 3,300 feet without de-rate. 1% derate for each 330 feet above 3,300 up to 6,600' / Above 6,600' Contact Tech Support for additional derating (Max Altitude to 13,123' with Derate)								
Switching Frequency: 2, 4, 8 or 12 kHz. See User Manual for Derate	Switching Frequency: 2, 4, 8 or 12 kHz Please see User Manual for Proper Derates at Carrier Frequencies above 4KHz. / Automatic fold back in case of overload								

1% derate for each 330 feet above 3,300

Performance Data (continued)

TABLE 9 - PERFORMANCE DATA 50-600 VAC (CONT'D)

AYK JCI Drive	Special Note: Plus Code +P940 = Base Drive Less Cover and Less Conduit Box / IP20							
ABB Model	AYK 580-01	AYK 580-01	AYK 580-01	AYK 580-01	AYK 580-01	AYK 580-01	AYK 580-01	AYK 580-01
Series	-032A-6	-041A-6	-052A-6	-062A-6	-077A-6	-099A-6	-125A-6	-144A-6
Motor Horsepower	30	40	50	60	75	100	125	150
Motor KW	22.4	29.8	37.3	44.8	56.0	74.6	93.3	111.9
Frame Size	R3	R5	R5	R5	R5	R7	R7	R8
Output Current Amps @ 40°C	32	41	52	62	77	99	125	144
Overload Current Rating	110% for 1 minute every 10 minutes							
Max Output Voltage	3 Phase 0 volts up to input voltage max.							
Rated Input Voltage	500/525/575/600 +10% -15% VAC 3 phase 48/63Hz +/- 3%							
Rated Input Current Amps @ 40°C (Use on Unit ID Nameplate)	32	41	52	62	77	99	125	144
Recommended Class T Fuse Size (Amps)	40	100	100	100	100	150	200	250
Maximum Power Cable Size AWG	2	2/0	2/0	2/0	2/0	500MCM	500MCM	(2) 300MCM
Heat Loss in watts 100 % load	619	835	1024	1240	1510	2061	2466	3006
Efficiency (%) min.	Approximately 98% at nominal load							
Environment								
Ambient Temperature	-15 to +50 °C (5 to 122 °F): No frost allowed / Output derated above +40 °C (104 °F)							
Storage Temperature	-40°C to 70°C -40 - 158° F							
Humidity	5 to 95% No condensation allowed Maximum relative humidity is 60% in the presence of corrosive gasses							
Altitude	MAX 3,300 feet without de-rate. 1% derate for each 330 feet above 3,300 up to 6,600' / Above 6,600' Contact Tech Support for additional derating (Max Altitude to 13,123' with Derate)							
Enclosure	Nema 1 Fan Cooled / with Conduit Box Included as Standard							
Weight kg approximate	11.80	28.30	28.30	28.30	28.30	54.00	54.00	69.00
Weight Lbs approximate	26.00	62.40	62.40	62.40	62.40	119.10	119.10	152.00
Input Frequency	48-63 Hz							
Imbalance	maximum +/- 3% of nominal phase to phase input voltage							
Fundamental Power Factor (cos phi)	0.98 at nominal load							
Frequency Resolution	0.01Hz							
Maximum motor cable length	100 M (R1); 200 M (R2); 300 M (R3-R9) max without output filters							
Heat Loss in BTU/Hr 100 % load	2114	2852	3497	4235	5157	7039	8422	10266
Air Flow m3/h	139	139	139	139	139	450	450	550
Air Flow ft3/min	82	82	82	82	82	265	265	265
Sinusoidal Vibration (IEC 60068-2-6)	Mechanical conditions: IEC 60068-2, 2....13.2Hz 1mm (0.04in) , 13.2...100Hz 7m/s2 (23 ft/s2)							
Output Current Derating								
Temperature 1% per degree C above 40°C IE: 50°C=output* 0.90	-15 to +50 °C (5 to 122 °F): No frost allowed / Output derated above +40 °C (104 °F)							
Altitude: 1% of output for every 330 feet above 3,300 feet	MAX 3,300 feet without de-rate. 1% derate for each 330 feet above 3,300 up to 6,600' / Above 6,600' Contact Tech Support for additional derating (Max Altitude to 13,123' with Derate)							
Switching Frequency: 2, 4, 8 or 12 kHz. See User Manual for Derate	Switching Frequency: 2, 4, 8 or 12 kHz Please see User Manual for Proper Derates at Carrier Frequencies above 4KHz. / Automatic fold back in case of overload							

1% derate for each 330 feet above 3,300

Performance Data (continued)

TABLE 9 - PERFORMANCE DATA 50-600 VAC (CONT'D)

AYK JCI Drive	Special Note: Plus Code +P940 = Base Drive Less Cover and Less Conduit Box / IP20		
ABB Model	AYK 580-01	AYK 580-01	AYK 580-01
Series	192A-6	242A-6	271A-6
Motor Horsepower	200	250	250
Motor KW	149.2	186.5	186.5
Frame Size	R9	R9	R9
Output Current Amps @ 40°C	192	242	271
Overload Current Rating	110% for 1 minute every 10 minutes		
Max Output Voltage	3 Phase 0 volts up to input voltage max.		
Rated Input Voltage	500/525/575/600 +10% -15% VAC 3 phase 48/63Hz +/- 3%		
Rated Input Current Amps @ 40°C (Use on Unit ID Nameplate)	192	242	271
Recommended Class T Fuse Size (Amps)	300	400	400
Maximum Power Cable Size AWG	(2) 500MCM	(2) 500MCM	(2) 500MCM
Heat Loss in watts 100 % load	4086	4896	4896
Efficiency (%) min.	Approximately 98% at nominal load		
Environment			
Ambient Temperature	-15 to +50 °C (5 to 122 °F): No frost allowed / Output derated above +40 °C (104 °F)		
Storage Temperature	-40°C to 70°C -40 - 158° F		
Humidity	5 to 95% No condensation allowed Maximum relative humidity is 60% in the presence of corrosive gasses		
Altitude	MAX 3,300 feet without de-rate. 1% derate for each 330 feet above 3,300 up to 6,600' / Above 6,600' Contact Tech Support for additional derating (Max Altitude to 13,123' with Derate)		
Enclosure	Nema 1 Fan Cooled / with Conduit Box Included as Standard		
Weight kg approximate	97.00	97.00	97.00
Weight Lbs approximate	213.90	213.90	213.90
Input Frequency	48-63 Hz		
Imbalance	maximum +/- 3% of nominal phase to phase input voltage		
Fundamental Power Factor (cos phi)	0.98 at nominal load		
Frequency Resolution	0.01Hz		
Maximum motor cable length	100 M (R1); 200 M (R2); 300 M (R3-R9) max without output fitters		
Heat Loss in BTU/Hr 100 % load	13954	16721	16721
Air Flow m3/h	1150	1150	1150
Air Flow ft3/min	677	677	677
Sinusoidal Vibration (IEC 60068-2-6)	Mechanical conditions: IEC 60068-2 , 2....13.2Hz 1mm (0.04in) , 13.2...100Hz 7m/s2 (23 ft/s2)		
Output Current Derating			
Temperature 1% per degree C above 40°C IE: 50°C=output* 0.90	-15 to +50 °C (5 to 122 °F): No frost allowed / Output derated above +40 °C (104 °F)		
Altitude: 1% of output for every 330 feet above 3,300 feet	MAX 3,300 feet without de-rate. 1% derate for each 330 feet above 3,300 up to 6,600' / Above 6,600' Contact Tech Support for additional derating (Max Altitude to 13,123' with Derate)		
Switching Frequency: 2, 4, 8 or 12 kHz. See User Manual for Derate	Switching Frequency: 2, 4, 8 or 12 kHz Please see User Manual for Proper Derates at Carrier Frequencies above 4KHz. / Automatic fold back in case of overload		

1% derate for each 330 feet above 3,300

Specifications

TABLE 12 - TECHNICAL SPECIFICATIONS

PRODUCT COMPLIANCE (COMPLETE LIST ON FOLLOWING PAGE)	
AYK580-01	CE, UL, cUL
SUPPLY CONNECTION	
Input voltage (U1)	
AYK580-xx-xxxA-2	208...240V
AYK580-xx-xxxA-4	380...480V
AYK580-xx-xxxA-6	515...600V
Input voltage tolerance	+10% / -15%
Phase	3-phase (1-phase, 240 V)
Frequency	48 to 63 Hz
Line Limitations	Max $\pm 3\%$ of nominal phase to phase input voltage
Power Factor (cos ϕ) at nominal load AYK580-01	0.98
Efficiency at rated power AYK580-01	98.0%
Power Loss	Approximately 2% of rated power
MOTOR CONNECTION	
Supported motor control	Scalar and vector
Supported motor types	Asynchronous motor, permanent magnet motor (vector), SynRM (vector)
Voltage	3-phase, from 0 to supply voltage
Frequency	0 to 500 Hz
Short Term Overload Capacity Variable Torque	110% for 1 min/10min
Peak Overload Capacity	1.35 for 2 second
Variable Torque	(2 sec / 10 min)
Switching Frequency	2, 4, 8 or 12 kHz Automatic fold back in case of overload
Acceleration/Deceleration Time	0 to 1800 s
Short Circuit Current Rating (SCCR)	100 ka with fusing
INPUTS AND OUTPUTS (DRIVE)	
2 analog inputs	Selection of Current/Voltage input mode is user programmable.
Voltage reference	0 (2) to 10 V, $R_{in} > 200 \text{ k}\Omega$
Current reference	0 (4) to 20 mA, $R_{in} = 100 \Omega$
Potentiometer reference value	10 V $\pm 1\%$ max. 20 mA
2 analog outputs	AO1 is user programmable for current or voltage. AO2 current
Voltage reference	0 to 10 V, $R_{load} > 100 \text{ k}\Omega$
Current reference	0 to 20 mA, $R_{load} < 500 \Omega$
Applicable potentiometer	1 k Ω to 10 k Ω
Internal auxiliary voltage	24 V DC $\pm 10\%$, max. 250 mA
Accuracy	$\pm 1\%$ full scale range at 25°C (77°F)
Output updating time	2 ms
6 digital inputs	12 to 24 V DC, 10 to 24 V AC, Connectivity of PTC sensors supported by a single digital input. PNP or NPN connection (5 DIs with NPN connection). Programmable

TABLE 12 - TECHNICAL SPECIFICATIONS (CONT'D)

Input Updating Time	2 ms
3 relay outputs	Maximum switching voltage 250 V AC/30 V DC. Maximum continuous current 2 A rms. Programmable, Form C
Adjustable filters on analog inputs and outputs	
All control inputs isolated from ground and power	
OPERATION	
Air temperature	0 to -15 °C (32 to 5 °F). -15 to +50 °C (5 to 122 °F): No frost allowed. Output derated above +40 °C (104 °F)
Installation site altitude	0 to 4000 m (13123 ft) above sea level Output derated above 1000 m (3281 ft)
Relative humidity	5 to 95% No condensation allowed Maximum relative humidity is 60% in the presence of corrosive gasses
Atmospheric pressure	70 to 106 kPa (10.2 to 15.4 PSI) 0.7 to 1.05 atmospheres
Vibration	Risk category IV Certified (IBC 2018)
ENVIRONMENTAL PROTECTIONS	
Chemical Gasses	Class 3C2
Solid Particles	Class 3S2 No conductive dust allowed
Pollution degree (IEC/EN 61800-5-1)	Pollution degree 2
PRODUCT COMPLIANCE	
Standards and directives	Low Voltage Directive 2006/95/EC EMC Directive 2004/108/EC 60721-3-3: 2002 60721-3-1:1997 Quality assurance system ISO 9001 and Environmental system ISO 14001 CE, UL, cUL, and EAC approvals Galvanic isolation according to PELV RoHS2 (Restriction of Hazardous Substances) EN 61800-5-1: 2007; IEC/EN 61000-3-12; EN61800-3: 2017 + A1: 2012 Category C2 (1st environment restricted distribution); Safe torque off (EN 61800-5-2) BACnet Testing Laboratory (BTL) Seismic (IBC, OSHPD) Plenum (AYK580-01 only)
EMC (according to EN61800-3)	AYK580-01 class C2 (1st environment restricted distribution)

Specifications (continued)

TABLE 12 - TECHNICAL SPECIFICATIONS (CONT'D)

STORAGE (IN PROTECTIVE SHIPPING PACKAGE)	
Air Temperature	-40 to +70 °C (-40 to +158 °F)
Relative Humidity	Less than 95% No condensation allowed Maximum relative humidity is 60% in the presence of corrosive gasses
Chemical Gasses	Class 1C2
Solid Particles	Class 1S2 Contact ABB regarding Class 1S3
Atmospheric pressure	70 to 106 kPa 0.7 to 1.05 atmospheres
Vibration (ISTA)	
R1...R4	In accordance with ISTA 1A
R5...R9	In accordance with ISTA 3E
TRANSPORTATION (IN PROTECTIVE SHIPPING PACKAGE)	
Air Temperature	-40° to 70°C (-40° to 158°F)
Relative Humidity	Less than 95% No condensation allowed Maximum relative humidity is 60% in the presence of corrosive gasses
Atmospheric Pressure	60 to 106 kPa (8.7 to 15.4 PSI) 0.6 to 1.05 atmospheres
Free Fall	R1: 76 cm (30 in) R2: 61 cm (24 in) R3: 46 cm (18 in) R4: 31 cm (12 in) R5: 25 cm (10 in)
Chemical Gasses	Class 2C2
Solid Particles	Class 2S2
Shock/ Drop (ISTA)	
R1...R4	In accordance with ISTA 1A
R5...R9	In accordance with ISTA 3E
Vibration (ISTA)	
R1...R4	In accordance with ISTA 1A
R5...R9	In accordance with ISTA 3E

Feature Overview

Communication

Protocols as standard (EIA-485): BACnet MS/TP, Modbus RTU, Johnson Controls N2

Available as plug-in options: BACnet/IP, Modbus TCP, PROFIBUS-DP, DeviceNet, EtherNet/IP, LonWorks (coming 2019)

Application functions

- Start interlock
- Delayed start
- Run permissive (damper monitoring)
- Override operation mode
- Real-time clock (scheduling)
- PID controllers for motor and process
- Motor flying start
- Motor preheating
- Energy optimizer and calculators
- Timer
- 2 or 3 wire start/stop
- Ramp to stop
- 2 independent adjustable accel/decel ramp

Protection functions

- Overvoltage controller
- Undervoltage controller
- Motor earth-leakage monitoring
- Motor short-circuit protection
- Motor overtemperature protection
- Output and input switch supervision
- Motor overload protection (UL508C)
- Phase-loss detection (both motor and supply)
- Under load supervision (belt loss detection)
- Overload supervision
- Stall protection
- Loss of reference
- Panel loss
- Ground fault
- External events
- Overcurrent
- Current limit regulator
- Transient/Surge protection (MOV and choke)

Panel functions

- First start assistant
- Primary settings for HVAC applications
- Hand-Off-Auto operation mode
- HVAC quick set-up

- Includes Day, Date and Time
- Operator Panel Parameter Backup (read/write)
- Full Graphic and Multilingual Display for Operator Control, Parameter Set-Up and Operating Data Display:
 - Output Frequency (Hz)
 - Speed (RPM)
 - Motor Current
 - Calculated % Motor Torque
 - Calculated Motor Power (kW)
 - DC Bus Voltage
 - Output Voltage
 - Heatsink Temperature
 - Elapsed Time Meter (resettable)
 - kWh (resettable)
 - Input / Output Terminal Monitor
 - PID Actual Value (Feedback) & Error Fault Text
 - Warning Text
 - Three (3) Scalable Process Variable Displays
 - User-Definable Engineering Units

Motor control features

- Scalar (V/Hz) and vector modes of motor control
- Supported motor types
 - Asynchronous motor,
 - Permanent magnet motor (vector),
 - SynRM (vector)Squared
- V/Hz shapes
 - Linear
 - Squared
- Energy optimization
- IR compensation
- Slip compensation
- Three (3) Critical Frequency Lockout Bands

PID Control

- One (1) Process PID
- Four (4) Integral Independent Programmable PID
- Setpoint Controllers (Process and External)
- External Selection between Two (2) Sets of Process
- PID Controller Parameters
- PID Sleep/Wake-U

Feature Overview (continued)

STANDARD FEATURES (UNIQUE TO AYK580-PF/CF) DRIVE WITH INPUT DISCONNECT OR CLASSIC BYPASS

Standards

- UL, 508

Features Unique to AYK580 Drive with Input Disconnect (AYK580-PF)

- Main Input Fused Disconnect ONLY
- Main Input Fused Disconnect Lockable
- (Open Position)
- Nema 3R units
- (Std. w/CPT, Heater & Thermostat Setting)
- All features as defined in Base Drive Features





~~Features Unique to AYK580 Drive Pack with Bypass (AYK580-CF)~~

- ~~Main Input Fused Disconnect ONLY~~
- ~~Main Input Fused Disconnect Lockable~~
- ~~(Open Position)~~
- ~~Control Power Transformer~~
- ~~Two Contactor Classic Bypass~~
- ~~(Mechanically interlocked)~~
- ~~Contactors are ABB (AF) Wide Range~~
- ~~Electronic Coil Type~~
- ~~Motor Bypass Electronic Overload selectable~~
- ~~(Class 10, 20 or 30 / Default Set Class 20)~~
- ~~Fused Drive Input Service Switch as Standard~~
- ~~Nema 3R units~~
- ~~(Std. w/CPT, Heater & Thermostat Setting)~~
- ~~All features as defined in Base Drive Features~~

Switches and LEDs

Switches

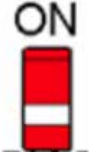
TABLE 13 - SWITCHES

SWITCH	DESCRIPTION	POSITION	
S4 (TERM)	EFB link termination. Must be set to the terminated (ON) position when the drive is the first or last unit on the link.		Bus not terminated
			Bus terminated
S5 (BIAS)	Activated on the biasing voltages to the bus. One (and only one) device, preferably at the end of the bus must have the bias on.		Bias off (default)
			Bias on

LEDS

Drive LEDs

There is a green POWER and a red FAULT LED on the front of the drive. They are visible through the panel cover but invisible if a control panel is attached to the drive. The following table describes the drive LED indications

Drive LEDs POWER and FAULT, on the front of the drive, under the control panel/panel cover

If a control panel is attached to the drive, switch to remote control (otherwise a fault is generated), and then remove the panel to be able to see the LEDs.

TABLE 14 - LEDES

LEDS OFF	LED LIT AND STEADY		LED BLINKING	
No power	Green (POWER)	Power supply on the board OK	Green (POWER)	Blinking: Drive in an alarm state Blinking for one second:
	Red (FAULT)	Active fault in the drive. To reset the fault, press RESET from the control panel or switch off the drive power.	Red (FAULT)	Drive selected on the control panel when multiple drives are connected to the same panel bus Active fault in the drive. To reset the fault, switch off the drive power.

Installation

Study the installation instructions of the AYK580-01 manual carefully before proceeding. Failure to observe the warnings and instructions may cause a malfunction or personal hazard.

WARNING: Before you begin, read the Safety Instructions in AYK580-01-IOM

1. Check the free space requirements

The drive must be installed on the wall. There are two alternative ways to install it.

NOTE: Do not install upside down.

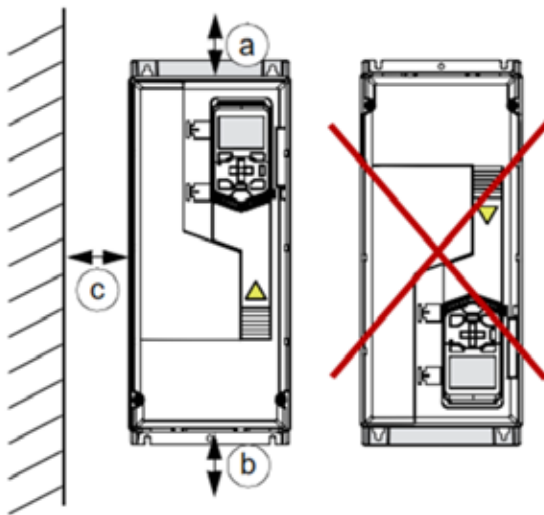

TABLE 15 - VERTICALLY ALONE CLEARANCES

FRAME SIZE	VERTICAL INSTALLATION - FREE SPACE					
	ALOVE (A)		BELOW (B)		BESIDE (C)*	
	MM	IN.	MM	IN.	MM	IN.
R1	200	7.87	150	5.91	150	5.91
R2	200	7.87	150	5.91	150	5.91
R3	200	7.87	200	7.87	150	5.91
R4	53	2.09	200	7.87	150	5.91
R5	100	3.94	200	7.87	150	5.91
R6	155	6.10	300	11.81	150	5.91
R7	155	6.10	300	11.81	150	5.91
R8	155	6.10	300	11.81	150	5.91
R9	200	7.87	300	11.81	150	5.91

3AXD00000586715

*Free space between the drive and other objects, for example, walls

FIGURE 45 - INSTALLING UNIT VERTICALLY ALONE

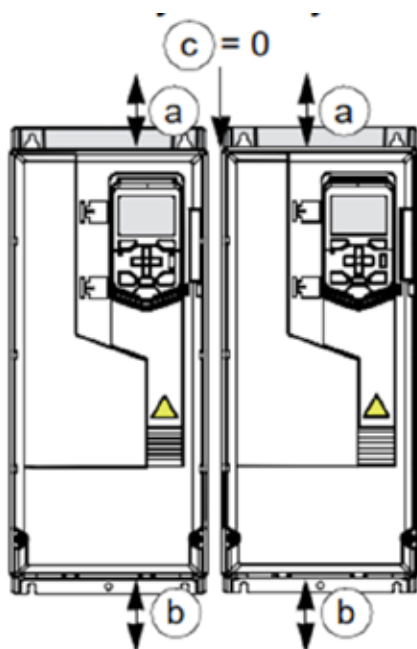

TABLE 16 - VERTICAL SIDE BY SIDE CLEARANCES

FRAME SIZE	VERTICAL INSTALLATION SIDE BY SIDE FREE SPACE					
	ALOVE (A)		BELOW (B)*		BESIDE (C)	
	MM	IN.	MM	IN.	MM	IN.
R1	200	7.87	200	7.87	0	0
R2	200	7.87	200	7.87	0	0
R3	200	7.87	200	7.87	0	0
R4	200	7.87	200	7.87	0	0
R5	200	7.87	200	7.87	0	0
R6	200	7.87	300	11.81	0	0
R7	200	7.87	300	11.81	0	0
R8	200	7.87	300	11.81	0	0
R9	200	7.87	300	11.81	0	0

* Free space below is always measured from the drive frame, not from the cable box.

FIGURE 46 - INSTALLING UNIT VERTICALLY SIDE BY SIDE

Installation (continued)

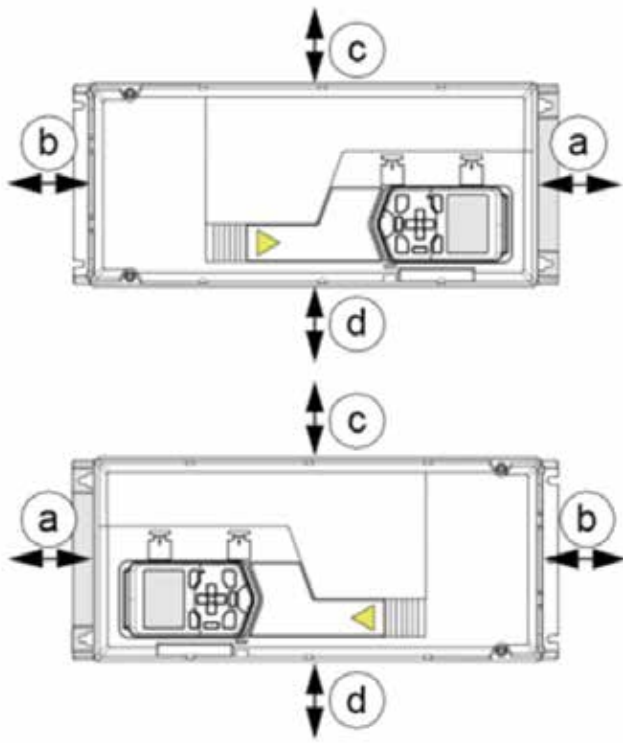

**TABLE 17 - HORIZONTAL SIDE BY SIDE
INSTALLATION CLEARANCES**

FRAME SIZE	IP21 (IP20)			
	ABOVE (A)		BELOW (B)*	
	MM	IN.	MM	IN.
R1	150	5.91	86	3.39
R2	150	5.91	86	3.39
R3	200	7.87	53	2.09
R4	30	1.18	200	7.87
R5	30	1.18	200	7.87
FRAME SIZE	SIDE UP (C)		SIDE DOWN (D)	
	MM	IN.	MM	IN.
R1	30	1.18	200	7.87
R2	30	1.18	200	7.87
R3	30	1.18	200	7.87
R4	30	1.18	200	7.87
R5	30	1.18	200	7.87

*Free space below is always measured from the drive frame, not from the cable box

FIGURE 47 - HORIZONTAL SIDE BY SIDE INSTALLATION

NOTE:

1. You can install IP21 / UL Type 1 drives horizontally but the installation meets IP29 requirements only.
2. In the horizontal mounting, the drive is not protected from dripping water
3. The vibration specification in the Ambient Conditions section may not be fulfilled.

EMC AND VAR SCREWS

WARNING: Do not install the drive with the EMC filters or VAR circuit enabled to an electrical power system that the filter is not rated for or unknown. This can cause danger and damage the drive.

NOTE: When the internal EMC filters are disconnected, the EMC protection of the drive is considerably reduced.

Identifying different types of electrical power systems

The power network can be determined with a RMS multimeter. When identified, the EMC and VAR screws may be correctly configured for that power system.

TABLE 18 - POWER SYSTEM IDENTIFICATION

U_{L-L}	U_{L1-G}	U_{L2-G}	U_{L3-G}	ELECTRICAL POWER SYSTEM TYPE	FIGURE
X	0.58x	0.58x	0.58x	TN System (Symmetrically grounded wye)	A
X	1.0x	1.0x	0	Corner-grounded Delta System (non-symmetrical)	B
X	0.866x	0.5x	0.5x	Midpoint-grounded Delta System (non-symmetrical)	C
X	Varying level versus time	Varying level versus time	Varying level versus time	IT System (ungrounded or high-resistance-grounded [>30 ohms] non-symmetrical)	D
X	Varying level versus time	Varying level versus time	Varying level versus time	TT System (the protective earth connection for the customer is provided by a local earth electrode, and there is another independently installed at the generator)	E

1. Input voltage line to line (U_{L-L})
2. Input voltage line 1 to ground (U_{L1-G})
3. Input voltage line 2 to ground (U_{L2-G})
4. Input voltage line 3 to ground (U_{L3-G})

T - Terra (ground)

N - Neutral

C - Combined

S - Separate

I - Isolated

TN-S = Terra Neutral - Separate

Earth and Neutral have separate conductors (3 wire single phase L, N, E).

IT = Isolated Neutral

Earth is either ungrounded or high-resistive (>30 ohms) non-symmetrical earth path.

TT = Tera Tera

Earth at source and Earth at destination (no earth conductor between source and consumer, the soil is used as the earth return path)

Installation (continued)

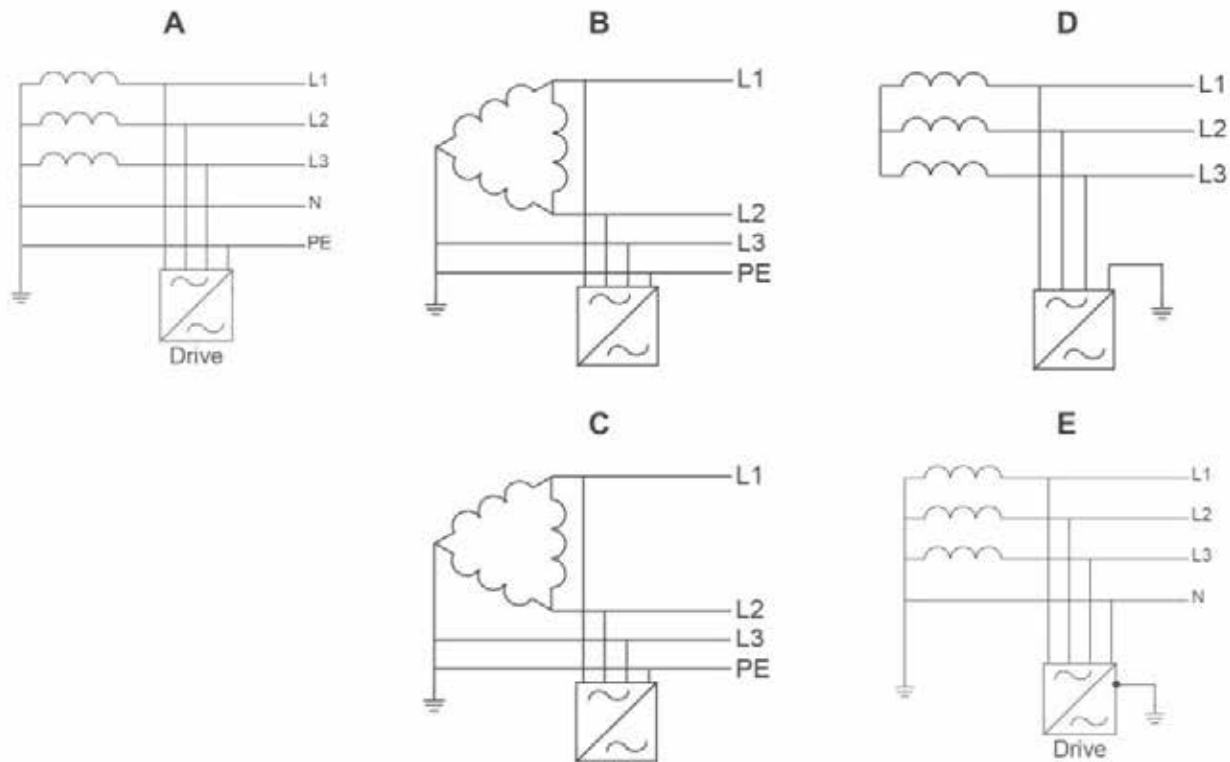
FIGURE 48 - ELECTRICAL POWER SYSTEM TYPES

Default EMC and VAR screws material

The following tables show the default material based on the drive frame and manufactured location (North America or except North America).

TABLE 19 - DEFAULT MATERIAL

FRAME	DEFAULT SCREW MATERIAL (NORTH AMERICA)			FRAME	DEFAULT SCREW MATERIAL (EXCEPT NORTH AMERICA)		
	EMC (DC)	EMC (AC)	VAR		EMC (DC)	EMC (AC)	VAR
R1...R3	Nylon	N/A	Metal	R1...R3	Nylon	N/A	Metal
R4...R5	Nylon	Nylon	Metal	R4...R5	Nylon	Metal	Metal
R6...R9*	Nylon	Nylon	Metal	R6...R9*	Nylon	Metal	Metal

NOTE: *The R7 has no EMC (DC) screw for 600 V.

EMC/VAR screw type selection for various power networks

The following describes the purpose of the EMC filter and the varistor (VAR) and how to configure based on the electrical power systems the drive will be connected.

WARNING: Disconnect EMC filter and VAR circuits when power network is unknown.

EMC filter

The EMC filter in the drive reduces the electromagnetic noise produced by the drive. Electromagnetic noise could interfere with or affect other electrical products. The EMC filter needs to be configured prior to installing the drive on the electrical power system to provide the proper EMC protection.

Varistor

The varistor (VAR) is a metal oxide varistor (MOV), which is used to protect the sensitive electronics in the drive caused by transient overvoltage conditions. The ground-to-phase varistor needs to be configured prior to installing the drive on the electrical power system to provide correct protection.

Replacement parts kits and torque values

TABLE 20 - SCREW KIT, HARDWARE R1-R4, R6-R9 PART NUMBER: 3AXD50000561261

QTY	DESCRIPTION	LOCATION	BIT SIZE	TORQUE
1	Screw, M4x12, COMBI, Torx, T20 Steel	EMC/VAR	T20	1.5 Nm
1	Screw, M4x12, PZ1, Nylon	EMC/VAR	PZ1	Hand tighten

TABLE 21 - SCREW KIT, HARDWARE R5 PART NUMBER: 3AXD50000561278

QTY	DESCRIPTION	LOCATION	BIT SIZE	TORQUE
1	Screw, M5x16, COMBI, Torx, T20 steel	EMC (AC)/VAR	T20	3.0 Nm
1	Screw, M6x16, PZ1, Nylon	EMC (AC)/VAR	PZ1	Hand tighten
1	Screw, M5x35, COMBI, Torx, T20 steel	EMC (DC)	T20	3.0 Nm
1	Screw, M6x35, PZ1, Nylon	EMC (DC)	PZ1	Hand tighten

TABLE 22 - AYK-580-01 NORTH AMERICA

		TN SYSTEM OF CORNER-GROUNDED DELTA SYSTEM	TN SYSTEM	CORNER-GROUNDED DELTA (B) AND MID- POINT-GROUNDED DELTA (C)	IT SYSTEM	TT SYSTEM
FRAME	CONNECTION	DEFAULT FIGURES A AND B	FIGURE A	FIGURES B AND C	FIGURE D	FIGURE E
R1...R3	EMC (DC)	Nylon	Metal ²	Nylon ¹	Nylon ¹	Nylon ¹
	VAR	Metal	Metal	Metal	Nylon ¹	Nylon ¹
R4 ³	EMC (DC)	Nylon	Metal ²	Nylon ¹	Nylon ¹	Nylon ¹
	EMC (AC)	Nylon	Metal ²	Nylon ¹	Nylon ¹	Nylon ¹
	VAR	Metal	Metal	Metal	Nylon ¹	Nylon ¹
R5 ³	EMC (DC)	Nylon	Metal ²	Nylon ¹	Nylon ¹	Nylon ¹
	EMC (AC)	Nylon	Metal ²	Metal ²	Nylon ¹	Nylon ¹
	VAR	Metal	Metal	Metal	Nylon ¹	Nylon ¹
R6...R9	EMC (DC)	Nylon	Metal ²	Nylon ¹	Nylon ¹	Nylon ¹
	EMC (AC)	Nylon	Metal ²	Metal ²	Nylon ¹	Nylon ¹
	VAR	Metal	Metal	Metal	Nylon ¹	Nylon ¹

NOTE: Bold text represents a change from the default material

¹ Metal screw must not be used

² Optional, for greater noise filtering

³ Frames R4 and R5 are evaluated for use on corner-grounded delta networks by UL standards. R4 and R5 frames may not be used on IEC installations with corner grounded networks.

Installation (continued)

TABLE 23 - AYK580-O1 EXCEPT NORTH AMERICA

FRAME	CONNECTION	TN SYSTEM	IT SYSTEM	TT SYSTEM
		DEFAULT FIGURES A	FIGURE D	FIGURE E
R1...R3	EMC (DC)	Metal	Nylon ¹	Nylon
	VAR	Metal	Metal	Nylon
R4 ³	EMC (DC)	Metal	Nylon ¹	Nylon
	EMC (AC)	Metal	Nylon	Nylon
	VAR	Metal	Metal	Nylon
R5 ³	EMC (DC)	Metal	Nylon ¹	Nylon
	EMC (AC)	Metal	Nylon	Nylon
	VAR	Metal	Nylon	Nylon
R6...R9	EMC (DC)	Metal	Nylon ¹	Nylon
	EMC (AC)	Metal	Nylon	Nylon
	VAR	Metal	Nylon	Nylon

NOTE: Bold text represents a change from the default material

¹ Optional, for greater noise filtering

² Frames R4 and R5 are evaluated for use on corner-grounded delta networks by UL standards. R4 and R5 frames may not be used on IEC installations with corner grounded networks.

Specifications

SCOPE

TABLE 24 - CONFIGURATION AVAILABILITY

DESCRIPTION	TYPE CODE	AYK550	AYK580
Bypass with fused disconnect	CF	YES	YES
Non-bypass with fused disconnect	PF	YES	YES
Bypass with non-fused disconnect	CD	YES	NO
Non-bypass with non-fused disconnect	PD	YES	NO

STANDARD PACKAGED DRIVES - FUNCTION

Non-bypass with fused disconnect (PF)

This product includes the AYK580-01 base drive with a fused rotary through-the-door input disconnect switch.

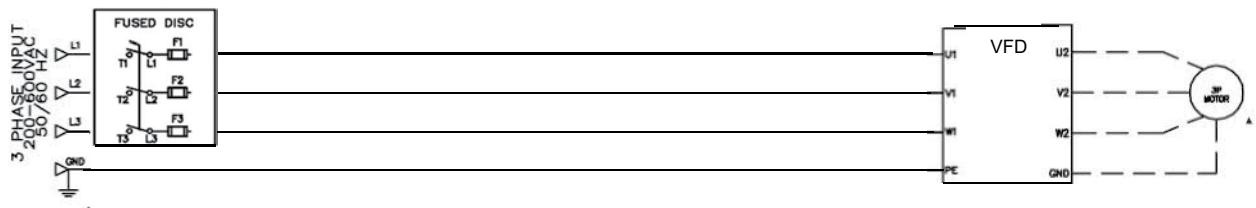
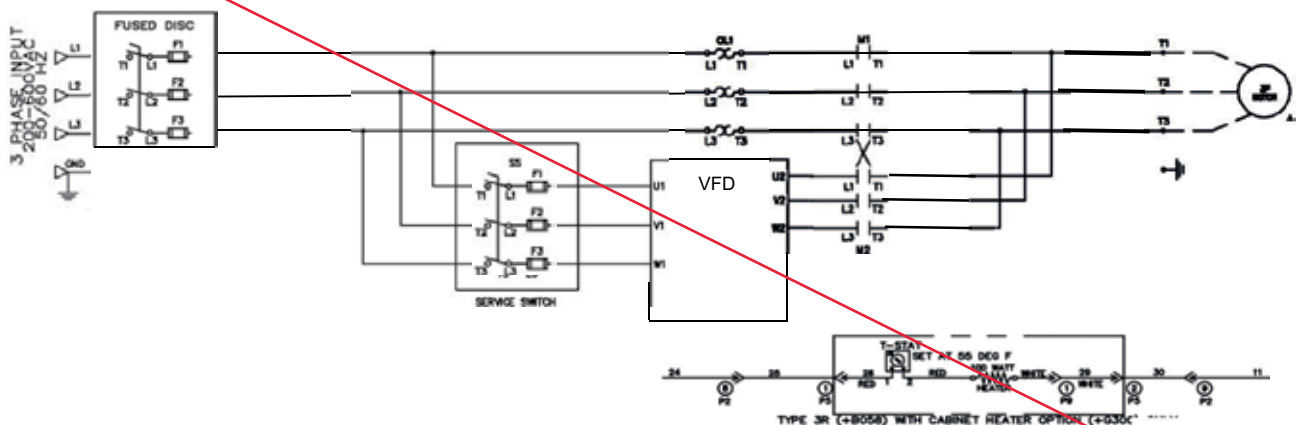

FIGURE 49 - NON-BYPASS WITH FUSED DISCONNECT (PF) CIRCUIT DIAGRAM

Electrical components

- Fused disconnect with Fast Acting class CC (R1 – R?) or Fast Acting J Fusing / DFJ fuses
- Variable frequency drive, AYK580
- Three phase motor (supplied by JCI)

~~Classic bypass with fused disconnect (CF)~~

~~This product includes the AYK580-01 base drive with a fused rotary through-the-door input disconnect switch plus a two-contactor (mechanically interlocked) bypass.~~

FIGURE 50 - CLASSIC BYPASS WITH FUSED DISCONNECT (CF) DIAGRAM

Specifications (continued)

~~Electrical components~~

- ~~• Fused disconnect with class J fuses~~
- ~~• Service switch with Fast Acting class CC (R1 – R?) or Fast Acting J Fusing / DFJ fuses~~
- ~~• Variable frequency drive, AYK580~~
- ~~• Two contactors, mechanically or electrically interlocked (ABB Type AF)~~
- ~~• Electronic overload relay (ABB Type EF)~~
- ~~• Three phase motor (supplied by JCI)~~

Standard Packaged Drives - Options

Options for the full line of products is shown below.

IMPORTANT: Some options will be included in all cases as noted.

CODE	DESCRIPTION	COMMENT
B058	UL Type 3R	Plus Code Required
G418	Alternate motor overload - one (1) standard rating below the standard motor overload for that unit (Bypass units only)	Optional on an SQ Basis If Required
G419	Alternate motor overload - two (2) standard ratings below the standard motor overload for that unit (Bypass units only)	Optional on an SQ Basis If Required
G441	Alternate motor overload - three (3) standard ratings below the standard motor overload for that unit (Bypass units only)	Optional on an SQ Basis If Required

Note: Depending on how the new electronic overloads line up with drive/motor amperages, the +G418, +G419 and +G441 option codes may not be required.

Special Order Packaged Drives

Definition

A “special order package” is defined as a unit that deviates in any way from the standard package as defined above.

Service Parts

Spare parts

ABB maintains a stock of the parts that may require replacement over the life of the drive unit. This includes fans, relays, fuses, etc. Contact ABB Drive Services for pricing and delivery.

Replacement Parts

Availability

Replacement parts are parts that do not normally fail over the life of the drive unit. This includes doors, covers, hinges, wires harnesses, etc. While ABB maintains a stock of these parts it is for use by the ABB factory to build new units. Availability as a separate replacement part to JCI may be limited.

Cabinet Doors

ABB purchases doors as part of a kit for a complete cabinet. Therefore, available as a replacement part is only as a complete cabinet. When a door is requested, ABB will supply a complete cabinet without electrical components. However, for bypass units, selector switches mounted on the door will be included.

Documentation

Each Configured unit will be shipped with electrical schematics supplied in a plastic bag within the enclosure.

Specifications (continued)

Overall Packaged Drive Specifications

TABLE 25 - OVERALL PACKAGED DRIVE SPECIFICATIONS

PACKAGE PRODUCT TYPES	
PF:	Drive with main fusible disconnect switch
CF:	Drive, 2 contactor classic bypass, main fusible disconnect, fusible drive input service switch, control power transformer and 2 selector switches (DRIVE-Off-BYPASS and HAND-OFF-AUTO) for control
PRODUCT OPTION CODES	
B058	UL Type 3R enclosure
G418	Motor overload relay, 1 size smaller (SQ Basis ONLY)
G419	Motor overload relay, 2 sizes smaller (SQ Basis ONLY)
G441	Motor overload relay, 3 sizes smaller (SQ Basis ONLY)
AGENCY APPROVALS	
UL508C:	VFD Only
UL508A:	Yes
cUL:	Yes
CSA	No – Available as a special quote request if required.
PACKAGED DRIVE NAME-PLATE RATINGS	
Short Circuit Current Rating:	100,000 RMS for all symmetrical Amperes (see drive specification / Exception: (575V SCCR 5KA)
INPUT:	
Voltage:	208 to 230 VAC 3-phase $\pm 10\%$, 60 Hz; 460 VAC 3-phase $\pm 10\%$, 60 Hz; 575 VAC 3-phase $\pm 10\%$, 60 Hz 380V/400/ 415 VAC $\pm 10\%$, 50/60 Hz (SQ Required / Available Upon Request)
FLA:	To be provided
Frequency:	60 Hz unit Frequency Tolerance 57-63 Hz 50/60 Hz unit Frequency Tolerance 48-63 Hz
OUTPUT:	
Voltage:	208 to 230 VAC 3-phase $\pm 10\%$, 60 Hz; 460 VAC 3-phase $\pm 10\%$, 60 Hz 380V/400/ 415 VAC $\pm 10\%$, 50/60 Hz; 460 VAC 3-phase $\pm 10\%$ 60 Hz, 575 VAC 3-phase $\pm 10\%$, 60 HZ
FLA:	See ratings table
Frequency:	See drive specifications
INPUT SUPPLY	
Input Voltage (U1):	208 to 230 VAC 3-phase $\pm 10\%$, 60 Hz; 460 VAC 3-phase $\pm 10\%$, 60Hz;380/400/ 415VAC $\pm 10\%$, 50/60 Hz; 575 VAC 3-phase $\pm 10\%$, 60 Hz
Frequency:	60 Hz unit Frequency Tolerance 57-63 Hz 50/60 Hz unit Frequency Tolerance 48-63 Hz
Line Limitations:	Max +/-3% of nominal phase to phase input voltage
Fundamental Power Factor (cosj):	0.98 at nominal load
LOAD CHARACTERISTICS	
Application:	HVAC Fans Factory Mounted
MOTOR	
HP:	1 to 75 HP at 208/ 230V; 1 to 75 HP at 380/400/415V; 1 to 150 HP at 460V, 1 to 125 HP at 575V
Design Type:	NEMA B Standard Efficiency
3-Phase FLA:	Less than or equal to the panel rating

Specifications (continued)

TABLE 23 - OVERALL PACKAGED DRIVE SPECIFICATIONS (CONT'D)

I peak (amps):	Estimating 6 times Motor FLA (with motor FLA not exceeding panel max amps) for a motor across the line start in bypass
Load Profile Ramp / Starting Time (sec):	We have assumed a 15 second start time

TABLE 26 - ENCLOSURE CHARACTERISTICS (UL TYPE 1)

FEATURE	DESCRIPTION
UL Enclosure Protection Class:	UL Type (NEMA) 1
Material:	
Type:	Galvanized Steel
Gauge:	
Enclosure:	14 gauge
Mounting Plate:	12 gauge
Internal Component Back plate:	12 gauge
Air Dams:	16 gauge
Remaining:	14 gauge
Assembly Type:	Bolt, Screw, & Rivet
Ventilation:	Forced air via VFD
Accessories:	
Drip Shield	No
Louvers	No
Heater	No
Drain Plug	No
Thermostat	No
Keypad Shield	No
Solar Shield – Door	No
Top Drip Shield	No
Conduit:	
Location/Placement:	
Entry	Rear (factory mount) / Bottom (field mount)
Exit	Rear (factory mount) / Bottom (field mount)
Knockout Dimensions:	
R1- R6:	Varies by type and rating. See dimension drawings.
Door:	
Type:	Removable
Hinge:	2 (R1/R2), 3 (R3), or 4 (R4-R7) loose joint
Closure:	2 (R1-R3) or 3 (R4-R7) non-locking quarter-turn Latches
Lifting Configurations:	Type PF Wall Mounting Tabs R1-R7 Type CF lifting holes R1-R7

Specifications (continued)

TABLE 27 - ENCLOSURE CHARACTERISTICS (UL TYPE 3R)

FEAUTRE	DESCRIPTION
UL Enclosure Protection Class:	UL Type (NEMA) 3R (+B058 option)
Material:	
Type:	Cold rolled commercial quality steel per ASTM Specification A-1008/A-1008M
Gauge:	
Enclosure:	14 gauge
Internal Component Back plate:	12 gauge
Air Dams:	16 gauge
Remaining:	14 gauge
Assembly Type:	Weld & rivet
Ventilation:	Forced air via VFD
Coating:	
Type:	Powder coat
Thickness:	3.0-3.5 mils
Surfaces/Components:	Enclosure surfaces powder coated
Color Description & Code:	JCI Champagne Brown
Certifications:	UL Recognized
Accessories:	
Drip Shield	Yes (R1-R6 frames)
Louvers	No
Heater	Yes
Drain Plug	No
Thermostat	Yes
Keypad Shield	Yes
Solar Shield – Door	Standard on frames R4-R7
Conduit:	
Location/Placement:	
Entry	Rear (factory mount) / Bottom (field mount)
Exit	Rear (factory mount) / Bottom (field mount)
Knockout Dimensions:	
R1- R6:	Varies by type and rating. See dimension drawings.
Door:	
Type:	Removable
Hinge:	2 (R1/R2), 3 (R3), or 4 (R4-R7) loose joint
Closure:	2 (R1-R3) or 3 (R4-R7) non-locking quarter-turn latches
Lifting Configurations:	Type PF Wall Mounting Tabs R1-R7 Type CF lifting holes R1-R7

Specifications (continued)

TABLE 28 - COMMON FEATURES IN UL TYPE 1 AND 3R

FEATURE	DESCRIPTION
Controls	
Motor Control:	VFD (all types) or (CF) 2 Contactor Classic Bypass with Electronic Coil (ABB AF Series Contactors)
Control Mode:	Variable torque
Operating Mode:	Keypad (PF/CF) & 2-Wire Bypass (CF)
Speed Command Reference:	0-10 Vdc
Control Switches:	Hand-Off-Auto & Drive-Off-Bypass (CF)
Contactors:	Bypass & Drive Output Mechanically Interlocked (CF)
Overload:	
Up to 80 Amp:	Electronic Class 10, 20 or 30 (Default Set for Class 20)
Greater than 80 Amp:	Current Transformer/Overload (electronic class 10, 20 or 30) Combination
Control Transformer:	Primary voltage selectable 208/230/460VAC @ 60Hz or 380V/400V @ 50/60 Hz or 575 VAC @ 60 Hz. ABB reserves the right to select the kVA rating on a transformer to meeting technical specifications
Control Inputs:	
PF:	Run, constant speed, safeties (all dry contact)
CF:	External speed reference, safeties (up to 2), Run time clock
Control Outputs:	fault (relay), frequency (analog & relay), running (relay)
Disconnecting Means	
Disconnect:	Rotary thru door fused, open-lockable door closed
Service Switch:	Rotary disconnect accessible from inside enclosure.
Branch circuit protection:	PF, CF max fuse size based on a target of 175% of drive FLA subject to ABB UL File max branch fuse specifications required to achieve short circuit current rating
Internal Wiring	
Type:	THHN, MTW, or silicon rubber UL3213
Wire marking specification:	Slip on markers or printed on wire
Wire color specification:	
Power	Black, size per UL508A Table 28.1
AC Control	Red (AC line), white (AC neutral), 16 AWG
DC Control	Blue (DC +supply), blue (common), 20 AWG
Environmental	
Ambient Temperature:	-15 deg C to 40 deg C (Derate required for up to 50 degree C required)
Storage Temperature:	-40 deg C to 70 deg C
Humidity:	<95% non-condensing
Altitude:	up to 1000m (3300 ft.) without derate (Derate required for high altitude)
Packaging	
UL Type 1 - PF	Corrugated paperboard box with plywood & insert internal (R1, R2) Wood pallet base & cardboard cover (R3-R6)
UL Type 1 - CF	Wood pallet base, corrugated paperboard wrapper and cover
UL Type 3R- PF/CF	Wood pallet base, corrugated paperboard wrapper and cover
Product Labeling	
General:	Per UL508A

Specifications (continued)

TABLE 26 - COMMON FEATURES IN UL TYPE 1 AND 3R (CONT'D)

FEATURE	DESCRIPTION
Exterior:	Warnings (risk of fire / shock, discharge wait)
	Caution (foreign voltage), & Controls (see controls section above)
Interior:	UL, UL Enclosure Type, & Ratings
Customized Base Drive	AYK580-01 brand labeled ACH580 with customized control panel

DEFINITION OF NEMA AND IEC ENVIRONMENTAL RATINGS

NEMA and IEC environmental ratings can be confusing. The following is a summary of the rating definitions and recommendations for application of each type supported by the AYK580 AC Drive product family.

NEMA 1, UL type 1

Indoor use primarily to provide a degree of protection against limited amounts of falling dirt

IP 2 1

(2) Protected against solid foreign objects of 12.5 mm diameter and greater

(1) Protected against certically falling water drops

Recommendation

Installation in clean environment such as clean room or in another enclosure with higher degree of protection.

NEMA 12, UL type 12

Indoor use primarily to provide a degree of protection against circulating dust, falling dirt, and dropping non-corro-sive liquids.

IP 5 4

(5) Ingress of dust is not totally prevented, but dust does not penetrate in a quantity to interfere with satisfactory operation of the apparatus or to impair safety.

(4) Water splashed against the enclosure from any direction does not have harmful effects.

Recommendation

Installation in environments with moderate to significant dust and contaminant particles. Acceptable for most applications on factory floors where dust is present but spraying liquids are not. Regular preventative maintenance for filter changing or cleaning. Inspect drive for dust or particle build up that may limit cooling in the future, clean as needed.

NEMA 3R, UL type 3R

Either indoor or outdoor use to provide a degree of protection against falling dirt, rain, sleet, and snow; and that will be undamaged by the external formation of ice on the enclosure.

IP 2 4

(2) Protected against solid foreign objects of 12.5mm diameter and greater

(4) Water splashed against the enclosure from any direction shall have no harmful effects

Recommendation

Installation in outdoor environments where rain and other precipitates are commonly present. Also suitable for indoor installation where dripping or splashing water is present. Not recommended where significant dust and contaminant particles are present.

DEFAULT CONTROL CONNECTIONS FOR THE HVAC DEFAULT

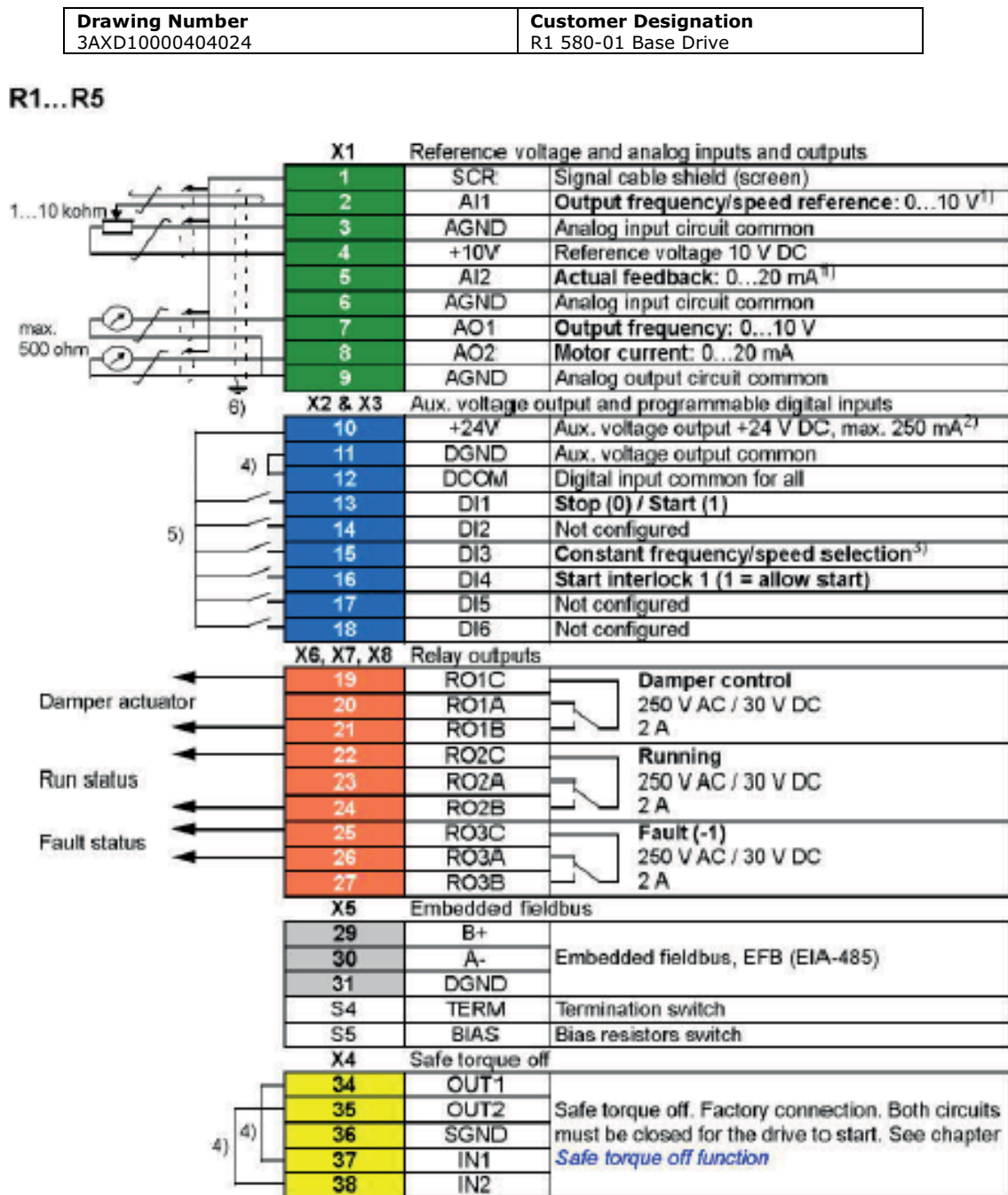

FIGURE 51 - DEFAULT CONTROL CONNECTIONS FOR THE HVAC DEFAULT

- Total load capacity of the auxiliary voltage output +24 VAC (X2:10) is 6.0 W (250 mA/24 VDC).
- Digital inputs DI1...DI5 also support 10 VAC to 24 VAC.
- Wire sizes:
 - 0.2...2.5mm² (24...14 AWG); terminals +24 V, DGND, DCOM, B+, A-, DGND, Ext. 24 V.
 - 0.14...1.5mm² (26...16 AWG); terminals DI, AI, AO, AGND, RO, STO
- Tightening torques: 0.5...0.6 N·m (0.4 lbf·ft)

EXTERNAL CONTROL CONNECTION TERMINALS, FRAMES R1...R5

The layout of the external control connection terminals of the R1 frame is shown in the following figure. Layout of the external control connection terminals is identical in frames R1...R5, but the location of the control board with the terminals is different in frames R3...R5.

Drawing Number
3AXD10000404024

Customer Designation
R1 580-01 Base Drive

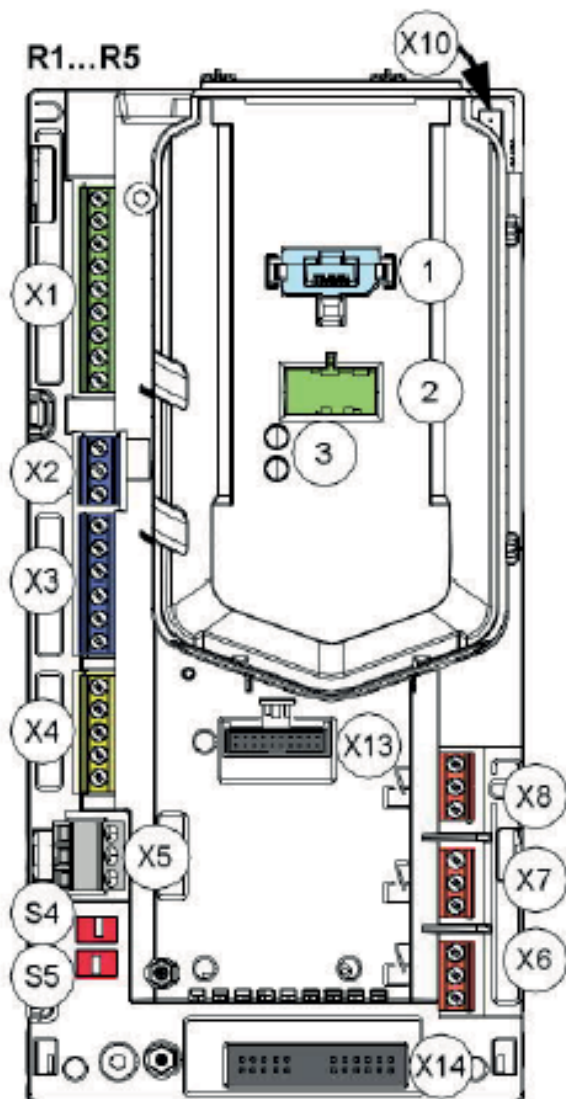

	Description
X1	Analog inputs and outputs
X2	Aux. voltage output
X3	Programmable digital inputs
X4	Safe torque off connection
X5	Embedded fieldbus
X6	Relay output 3
X7	Relay output 2
X8	Relay output 1
X10	Auxiliary fan connection (IP55)
X13	Option slot 1 (fieldbus adapter modules)
X14	Option slot 2 (I/O extension modules)
S4, S5	Termination switch (S4), bias resistor switch (S5), see section Switches See Switch Orientations Below
1	Panel Port (Control Panel Connection)
2	Cold configuration connection. This connector is used with the CCA-01 configuration adapter.
3	Power OK and Fault LEDs. See section LEDs below

FIGURE 52 - EXTERNAL CONTROL CONNECTION TERMINALS, FRAMES R1...R5

OVERVIEW OF POWER AND CONTROL CONNECTIONS

The following logical diagram shows the power connections and control interfaces of the drive.

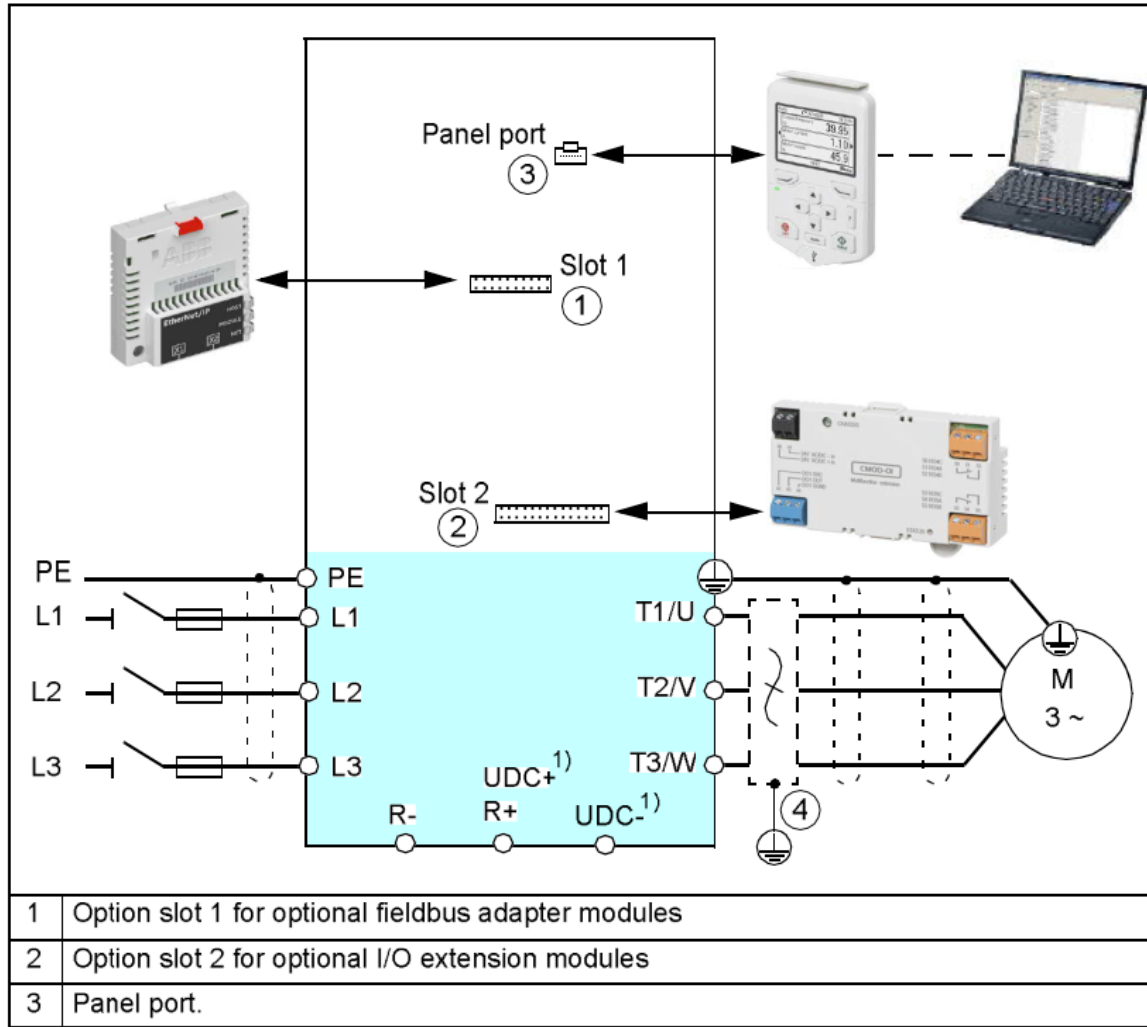





FIGURE 56 - POWER CONNECTIONS AND CONTROL INTERFACES

Switches and LEDs

Switches

TABLE 30 - SWITCHES

SWITCH	DESCRIPTION	POSITION	
S4 (TERM)	EFB link termination. Must be set to the terminated (ON) position when the drive is the first or last unit on the link.		Bus not terminated
			Bus terminated
S5 (BIAS)	Activated on the biasing voltages to the bus. One (and only one) device, preferably at the end of the bus must have the bias on.		Bias off (default)
			Bias on

LEDS

Drive LEDs

There is a green POWER and a red FAULT LED on the front of the drive. They are visible through the panel cover but invisible if a control panel is attached to the drive. The following table describes the drive LED indications

Drive LEDs POWER and FAULT, on the front of the drive, under the control panel/panel cover

If a control panel is attached to the drive, switch to remote control (otherwise a fault is generated), and then remove the panel to be able to see the LEDs.

TABLE 31 - LEDS

LEDS OFF	LED LIT AND STEADY		LED BLINKING	
No power	Green (POWER)	Power supply on the board OK	Green (POWER)	Blinking: Drive in an alarm state Blinking for one second:
	Red (FAULT)	Active fault in the drive. To reset the fault, press RESET from the control panel or switch off the drive power.	Red (FAULT)	Drive selected on the control panel when multiple drives are connected to the same panel bus
				Active fault in the drive. To reset the fault, switch off the drive power.

3AXD50000490134

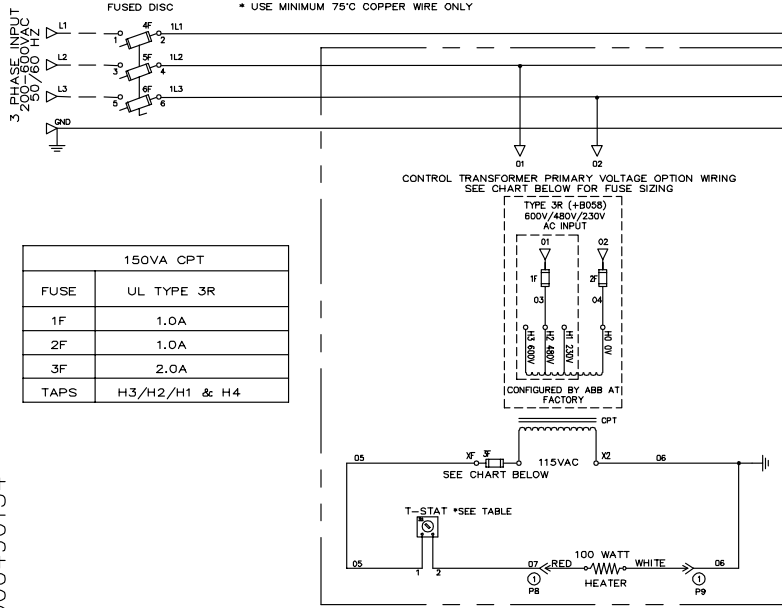

CUSTOMER TORQUE REQUIREMENTS

FRAME	TERMINAL TORQUE (Nm)			
	U	V	W	PE
R1	1.0	1.0	1.0	1.5
R2	1.5	1.5	1.5	1.5
R3	3.5	3.5	3.5	1.5
R4	4.0	4.0	4.0	2.9
R5	5.6	5.6	5.6	2.2
R6	30	30	30	9.8
R7	40	40	40	9.8
INPUT TERMINAL DISCONNECT TORQUE (Nm)				
OS30FACC12	1.9			
OS60J12	3.4			
OS100J03	5.7			
OS200J03	22			
OS400J03	42			

UH - NON-BYPASS DRIVE ONLY
 PF - NON-BYPASS WITH FUSED DISC
 B058 - TYPE 3R
 - REFER TO PANEL LABEL FOR OPTIONS

LEGEND

- OPTIONAL PANEL COMPONENTS
- WIRING PROVIDED BY ABB
- - - - - WIRING NOT PROVIDED BY ABB
- - - - - WIRING CONFIGURATION - FACTORY/FIELD
- - TERMINAL POINT
- ▲ - REMOTE DEVICE (BY OTHERS)
- ▽ - WIRE CONTINUATION POINT

NOTES:

- A CONTACT CLOSURE BETWEEN 10 AND 13 CAUSES THE DRIVE TO START. (10 TO 16 MUST BE CLOSED)
- A CONTACT CLOSURE BETWEEN 10 AND 15 WILL CAUSE DRIVE TO RUN AT A PRESET SPEED. SET PARAMETER 28.26 TO DESIRED SPEED.
- A CONTACT CLOSURE BETWEEN 10 AND 16 WILL ENABLE THE MOTOR TO RUN

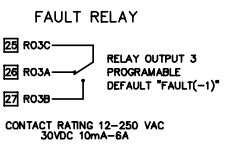
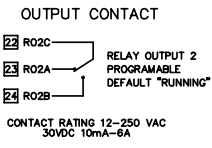
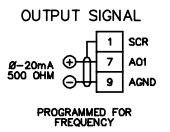
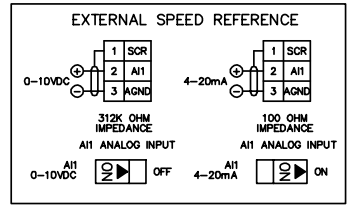
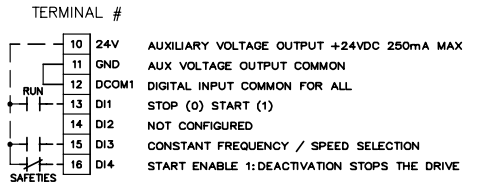
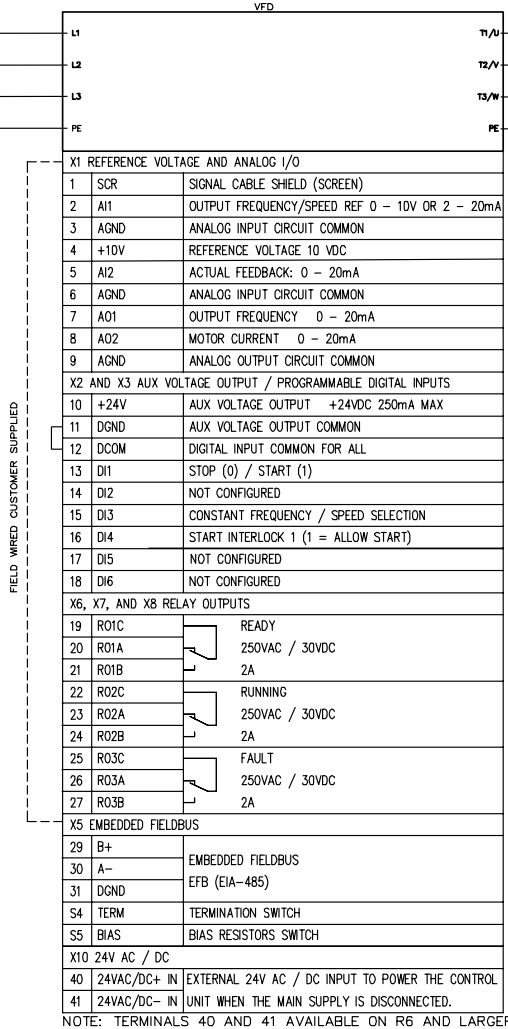

FIGURE 57 - N1-N3R FUSED DISC NON BYPASS



Attachments Section

Product Type: Semi-Custom Air Handling Units

Unit Tags: Various

SINGULAR. MODULAR. COMPACT.

STACK FAN

A Stack Fan is a direct drive plenum fan with the flexibility to be used singularly or in parallel so you can construct a multiple fan system to meet the exact performance criteria for your application.

APPLICATIONS

Systems

- High performance VAV systems
- Air Handlers
- Rooftop units
- General supply and return exhaust
- Telecom data centers
- Clean rooms

Commercial Facilities

- Hospitals & healthcare facilities
- Universities & schools
- Commercial facilities

THE STACK FAN ADVANTAGE

Fan redundancy, ensuring the system continues to perform, even with a fan in the array shut off.

Stackable, individual units allow flexibility to meet any design criteria.

Direct drive premium NEMA motor eliminates bearings, belts, and pulleys, reducing maintenance costs significantly.

Motor base optimization eliminates wasteful, costly materials not necessary.

Eliminates all resonance conditions.

Lau's proprietary balance process improves on currently accepted AMCA specifications by considering the effects of the rotating mass's on the unit as well as the whole, not just the wheel.

Size offerings available for replacement through a standard door opening.

Sound panels enclose the fan and motor to reduce attenuation levels.

STACK FAN FEATURES

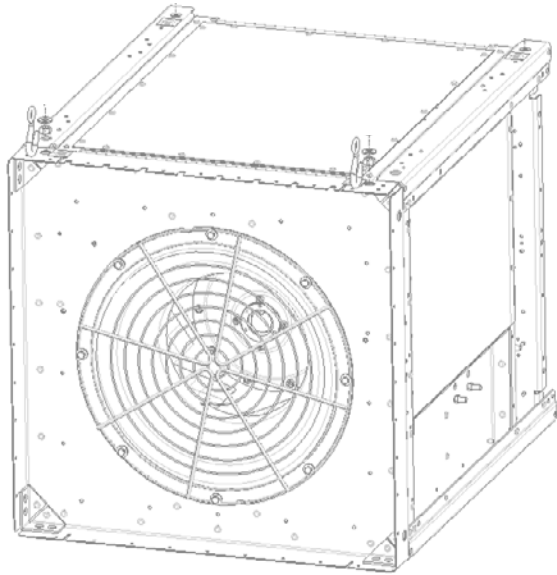

ROBOTICALLY WELDED ALUMINUM AIRFOIL WHEEL

Wheels available in 9-blade, 12-blade configurations.
Available in wheel widths of 80%, 100% & 120%



GALVANIZED STEEL FRAME AND BASE

Assembled with high strength fasteners



INDUSTRY BEST VIBRATION PERFORMANCE

Assembly balanced to G6.3



EASY TO INSTALL

Integrated lifting points



LOW MAINTENANCE

Less time, lower costs. No belts, bearings or sheaves & fewer filter replacements.



RELIABILITY PERFORMANCE

Fans designed to perform consistently throughout the entire speed range—no resonant conditions in the operating range.



SIMPLE, STACKABLE APPLICATION

Simplified application of multiple fans. Multi-fan arrangements reduce airway length and create uniform coil coverage.

MORE STACK FAN FEATURES

- Available sizes: 10" through 25"
- 9 or 12 blade, aluminum airfoil wheel
- AMCA rated
- G90 mechanically fastened frame
- Performance: up to 10 in-wg and 76% efficiency

STACK FAN SPECIFICATIONS

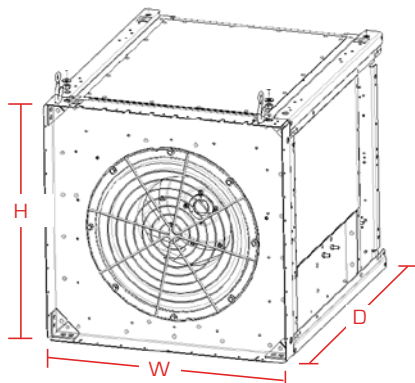

STACK FAN DIMENSIONAL DATA					
WHEEL SIZE	HOUSING DIMENSIONS			MAX STACKED CUBES**	MAX MOTOR FRAME SIZE
	WIDTH (W)	HEIGHT (H)	DEPTH (D)*		
10	20.03	18.79	24.56	4	184T
12	22.66	20.89	25.81	4	184T
13	24.53	22.4	28.06	4	213T
15	26.78	24.2	30.63	3	215T
16	29.03	25.75	35.31	3	254T
18	30.41	30.00	36.77	3	256T
20	33.75	34.00	37.85	3	284T
22	37.41	37.10	39.19	2	284T
25	41.43	41.00	40.57	2	284T

*Cabinet dimension only. Overall length including motor will vary based on motor type, size, and manufacturer.

**Recommended max stacked cubes based on max hp. Higher stacks are possible with smaller hp – contact Lau engineering

STACK FAN OPTIONS

PIEZOMETER

A system for measuring pressure consisting of a pressure taps installed on the inlet cone

SHAFT GROUNDING KIT

Diverts stray voltage spikes to ground, extending motor bearing life

SPECIAL MOTORS

Lau can install most NEMA rated motors.

INLET DAMPER

Controls the air-flow to each fan or array

INLET SCREEN

A safety feature for the intake of the fan

CLOTH WRAP

Recommended for the clean-room applications to help reduce in-stream particles

OUTLET GUARD

A safety feature for the outlet area insuring no hand penetration into moving parts



SMART. RESPONSIBLE. EFFECTIVE.

STACK FAN

Stack Fan arrays offer maximum performance, reliability and efficiency. The advantages of a proven design multiplied to achieve synergy and security.

SMALLER CABINET FOOTPRINT

Stackable, individual units that allow flexibility to meet any design criteria. The Stack Fan unit design is compact and configurable.

REDUCED ECOLOGICAL FOOTPRINT

Lau's experienced design engineers and technicians utilize state of the art engineering and laboratory facilities to provide solutions to help meet the needs of the present without compromising the ability of future generations to meet their own needs.

In addition, Lau products are produced in multiple factory locations which ensures optimized logistics and freight cost savings.

REDUNDANCY / RELIABLE

Stack Fan's redundancy ensures that the system continues performing, even with a fan in the array shut off

REDUCE MAINTENANCE COSTS

The Stack Fan direct drive plenum NEMA motor eliminates bearings, belts and pulleys, thus reducing maintenance costs significantly. Also, motor base optimization eliminates wasteful and costly materials not necessary.

INDUSTRY LEADING MANUFACTURING

MOVING AIR FOR OVER 80 YEARS

Lau leads the industry as the largest manufacturer of air-moving components and fan systems in North America for the heating, ventilation, air conditioning (HVAC) and refrigeration industries.

PRECISION

Each wheel is robotically welded to ensure the best quality and consistency.

CUTTING EDGE TECHNOLOGY

Our manufacturing facilities are equipped with the latest fabrication equipment.

A BALANCED APPROACH

Lau uses state of the art balancing systems which allow us to offer precision balancing grades.

PROVEN RESULTS

Lau manufacturing is a foundation of our production philosophies resulting in measurable efficiency in every product.

CERTIFIED PERFORMANCE

Lau is certified under the ISO9001/2008 standard of performance and we pride ourselves on continuous measurable improvements and accountability.

EFFICIENT SOLUTIONS

Fans are produced in multiple factory locations which ensures optimized logistics and freight cost savings.

CBD6 COUNTERBALANCED BACKDRAFT DAMPER

STANDARD CONSTRUCTION

FRAME

6063T5 extruded aluminum .125" (3.2) wall thickness.

BLADES

6063T5 extruded aluminum .070" (1.8) wall thickness with extruded vinyl edge seals.

BEARINGS

Zytel.

LINKAGE

1/8" x 1/2" (3 x 13) aluminum tiebars.

COUNTERBALANCE

Zinc plated bar on blades (except top blade). Adjustable for final "on the job" setting.

FINISH

Mill.

MAXIMUM SIZE

Single section – 48"w x 52"h (1219 x 1321).
Assembly of sections – unlimited.

MINIMUM SIZE

6" w x 10"h (152 x 254)

TEMPERATURE LIMITS

-40°F (-40°C) minimum and +200°F (93°C) maximum.

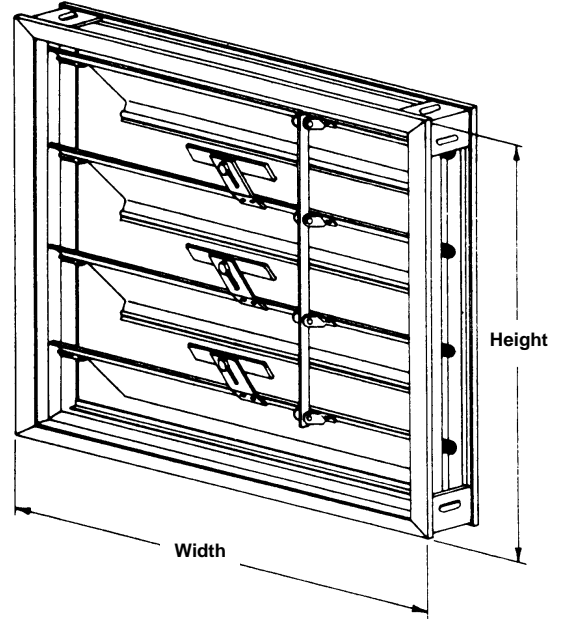

VARIATIONS

The following variations to the CBD6 are available at additional cost:

- Special finishes
- Bird or insect screens

NOTES

1. Unit furnished approx. 1/4" (6) smaller than given opening dimensions.
2. Dimensions shown in parentheses () indicate millimeters.

FRAME CONSTRUCTION

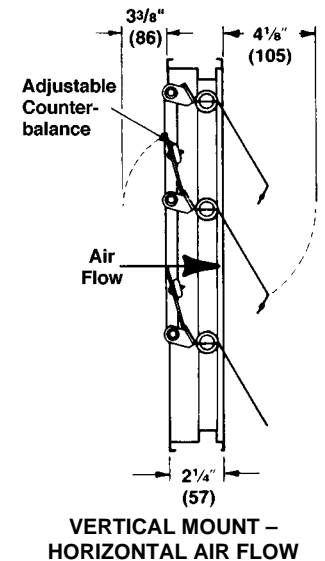
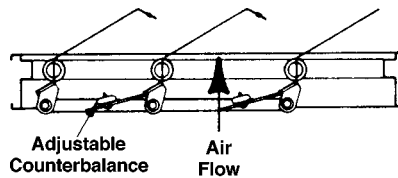
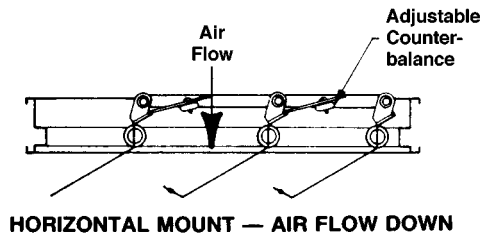
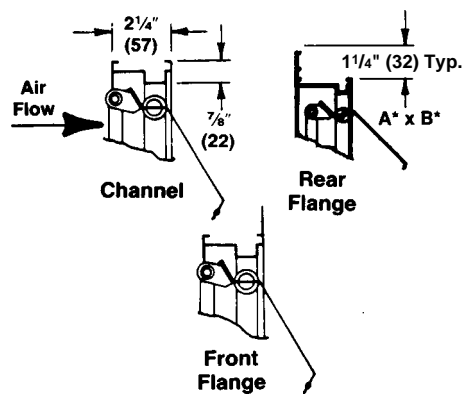

SUGGESTED SPECIFICATION

Furnish and install, at locations shown on plans or in accordance with schedules, heavy duty backdraft dampers that meet the following minimum construction standards: Frame shall be .125" (3.2) wall thickness 6063T5 extruded aluminum with 12 gage (2.8) galvanized steel structural brace at each corner. Blades shall be .070" (1.8) wall thickness 6063T5 extruded aluminum with extruded vinyl blade edge seals mechanically locked into blade edge. Adhesive or clip on type seals are unacceptable. Bearings shall be corrosion

resistant, long life synthetic type for quiet operation. Linkage shall be 1/2" (13) wide tiebar connected to stainless steel pivot pins. Dampers shall be designed for maximum 3500 fpm spot velocities and minimum 4 inches w.g. back pressure depending on damper size. Dampers shall be in all respects equivalent to Ruskin model CBD6.

INSTALLATION

1. When used in fan discharge applications, damper should be located at least one-half the fan diameter away from the fan.
2. For proper operation, damper must be installed square and free from racking.

3. Bracing of multiple section assemblies:
The CBD6 is intended to be self supporting only in the largest single section size. Multiple section damper assemblies may require bracing to support the weight of the assembly and to hold against system pressure. Ruskin recommends appropriate bracing to support the damper horizontally at least once for every 8 feet of damper width. Vertical assemblies and higher system pressures may require more bracing.

PERFORMANCE DATA

DAMPER PERFORMANCE

DAMPER WIDTH	MAXIMUM BACK PRESSURE	MAXIMUM SYSTEM VELOCITY	LEAKAGE*		BLADES START TO OPEN	BLADES FULLY OPEN
			Percent of Max. Flow	CFM/ Sq. Ft.		
48" (1219)	4.0" w.g.	2500 FPM	.6%	15	.01" w.g.	.05" w.g.
36" (914)	8.0" w.g.	2500 FPM	.6%	15		
24" (610)	12.0" w.g.	2500 FPM	.7%	17.5		
12" (305)	16.0" w.g.	2500 PFM	1%	25		

*Leakage information based on pressure differential of 1" w.g. tested per AMCA Std. 500.

DAMPER PRESSURE DROP (24" x 24")

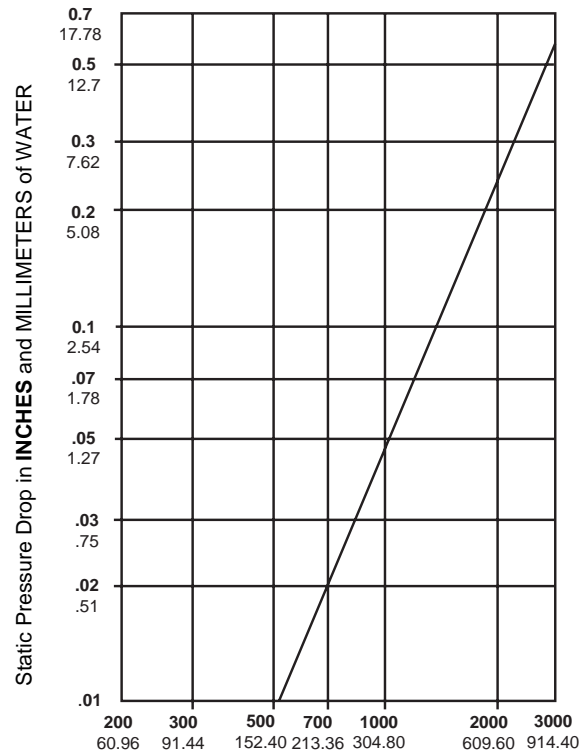

Air Velocity in FEET and METERS per minute through FACE AREA.
Tested per AMCA Std. 500, Fig. 5.3, ductwork upstream and downstream.

CD60 LOW LEAKAGE CONTROL DAMPER

High Performance Airfoil
Class 1A Leakage Rated

APPLICATION

The CD60 is a low leak, galvanized steel damper designed with airfoil blades for higher velocity and pressure HVAC systems. It meets the leakage requirements of the International Energy Conservation Code by leaking less than 3 cfm/sq. ft. at 1" of static pressure and is AMCA licensed as a Class 1A damper.

STANDARD CONSTRUCTION

FRAME

5" x 1" x 16 gage (127 x 25 x 1.6) galvanized steel hat channel reinforced with corner braces for structural strength equal to 11 gage (3.05) channel frames. Low profile 3½" x ⅜" x 16 gage (89 x 10 x 1.6) galvanized steel channel top and bottom frame on dampers under 12" (305) high.

BLADES

Galvanized steel airfoil shaped, double skin construction of 14 gage (2.0) equivalent thickness, 6" (152) wide. Parallel or opposed action.

SEALS

Ruskiprene blade edge seals and flexible metal compressible jamb seals.

BEARINGS

Stainless steel sleeve.

LINKAGE

Concealed in frame.

AXLES

½" (13) plated steel hex. Removable control shaft extends 6" (152) beyond frame.

MAXIMUM SIZE

Single section – 60"w x 72"h (1524 x 1829).
Multiple section assembly – Unlimited size.

MINIMUM SIZE

Single blade – 8"w x 6"h (203 x 152).
Two blades, parallel or opposed action: 8"w x 10"h (203 x 254).

TEMPERATURE LIMITS

-72°F (-60°C) minimum and +275°F (+135°C) maximum.

FEATURES

- Airfoil blade design for low pressure drop and less noise generation.
- One piece interlocking frame design to reduce racking.
- Positive lock axles, noncorrosive bearings and shake proof linkage for low maintenance operation.
- Blade edge seals mechanically lock into the blade for superior sealing.

OPTIONS

- Factory-installed, pneumatic and electric actuators.
- Enamel and epoxy finishes.
- SP100 Switch Package to remotely indicate damper blade position.
- Heavier frame construction with U-channel frame.
- Front, rear or double flange frame with or without bolt holes.
- Face and bypass configurations.

NOTE: Dimensions shown in parenthesis () indicate millimeters.

*Units furnished approximately ¼" (6) smaller than given opening dimensions.

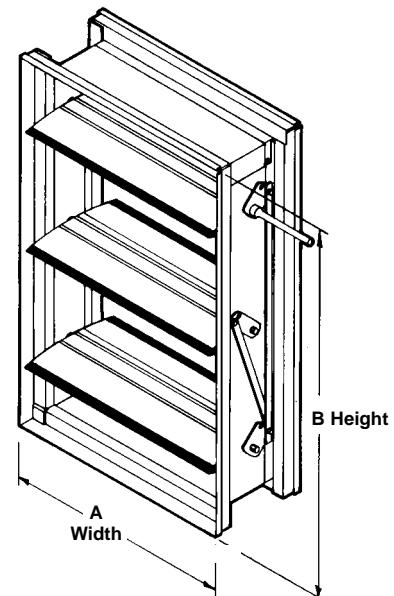

CD60 AMCA LICENSED PERFORMANCE DATA

CD60 PRESSURE LIMITATIONS

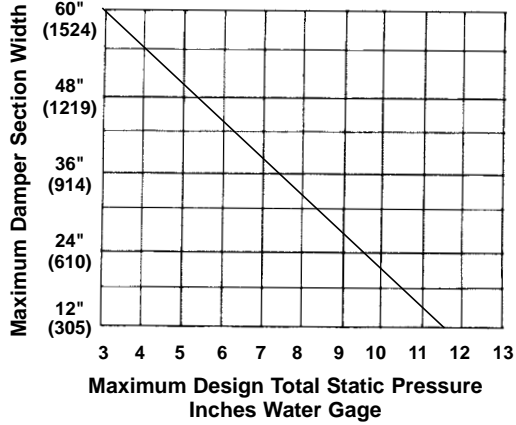

The CD60 may be used in systems with total pressures exceeding 3.5" by reducing damper section width as indicated. Example: Maximum design total pressure of 8.5" w.g. would require CD60 damper with maximum section width of 36" (914). Pressure limitations shown above allow maximum blade deflection of 1/180 of span on 60" (1524) damper widths. Deflections in other damper widths (less than 48" [1219]) at higher pressures shown will result in blade deflection substantially less than 1/180 of span.



Ruskin Company certifies that the CD60 shown herein is licensed to bear the AMCA Seal. The ratings shown are based on tests and procedures performed in accordance with AMCA Publication 511 and comply with the requirements of the AMCA Certified Ratings Program. The AMCA International Certified Ratings Seal applies to Air Performance and Air Leakage.

Pressure/Class	Leakage, L/s/m ² (ft ³ /min/ft ²)			
	Required Rating		Extended Ranges (Opt.)	
	1" (0.25 kPa)	4" (1.0 kPa)	8" (2.0 kPa)	12" (3.0 kPa)
1A	3 (15.2)	N/A	N/A	N/A
1	4 (20.3)	8 (40.6)	11 (55.9)	14 (71.1)
2	10 (50.8)	20 (102)	28 (142)	35 (178)
3	40 (203)	80 (406)	112 (569)	140 (711)

DAMPER WIDTH (INCHES)	1 IN. W.G.	4 IN. W.G.	8 IN. W.G.
12" (305)	IA	I	II
24" (610)	IA	I	II
36" (914)	IA	I	NA
48" (1219)	IA	I	NA
60" (1524)	IA	I	NA

Leakage testing conducted in accordance with AMCA Standard 500-D-98. Torque applied holding damper closed, 5 in. lbs./sq. ft. on opposed blade dampers and 7 in. lbs./sq. ft. on parallel blade

dampers. Air leakage is based on operation between 50°F to 104°F. All data corrected to represent standard air density 0.075 lbs/ft³.

VELOCITY VS. PRESSURE DROP

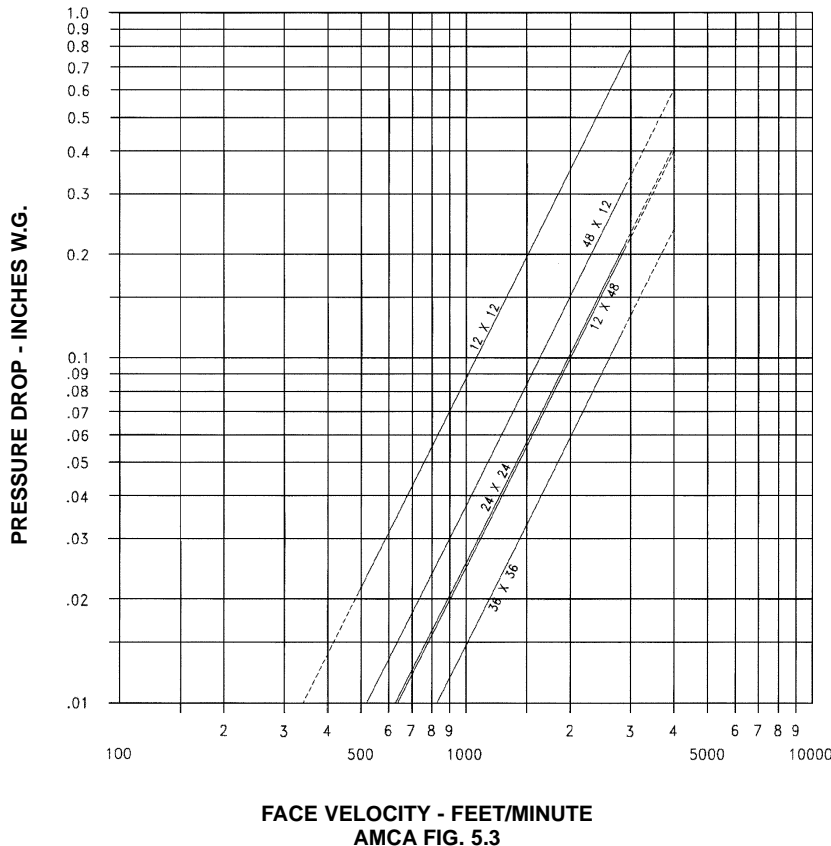

CD60 sizes 12 x 12, 24 x 24, 48 x 12, 12 x 48, 36 x 36 (305 x 305, 610 x 610, 1219 x 305, 305 x 1219, 914 x 914)

All data corrected to represent standard air at a density of 0.075 lbs/ft³.

CD60 SUGGESTED SPECIFICATION

Furnish and install, at locations shown on plans, or in accordance with schedules, control dampers that meet the following minimum construction standards. Frame shall be 16 gage (1.6) galvanized steel structural hat channel with tabbed corners for reinforcement for 11 gage (3.05) structural equivalence. Blades shall be 14 gage (2.0) equivalent thickness galvanized steel, roll-formed airfoil type for low pressure drop and low noise generation. Blade edge seals shall be Ruskiprene type or equivalent suitable for -72°F (-60°C) to +275°F (+135°C) mechanically locked into the blade edge. Adhesive or clip-on type seals are unacceptable. Jamb seals shall be flexible metal, compression type to prevent leakage between blade end and damper frame. Blade end overlapping frame is unacceptable.

Bearings shall be corrosion resistant, permanently lubricated stainless steel sleeve type turning in an extruded hole in the damper frame. Axles shall be hexagonal positively locked into the damper blade. Linkage shall be concealed out of airstream, within the damper frame to reduce pressure drop and noise. Submittal must include leakage, maximum air flow and maximum pressure ratings

based on AMCA Publication 500. Damper shall meet the leakage requirements of the International Energy Conservation Code by leaking less than 3 cfm/sq. ft. at 1" of static pressure and shall be AMCA licensed as a class 1A damper. Dampers shall be Ruskin CD60 model.

Specifier Select Options.

SP100: Dampers shall be equipped with factory installed damper position indication switch package. The switch package shall include two position indication switches linked directly to the damper blade to provide full open and full closed damper blade position. The switch package shall be capable of interfacing with the HVAC control system and provide remote damper blade position status. Switch package shall be Ruskin Model SP-100.

Factory Mounted Damper Actuators: If control damper actuators are required, they shall be furnished and mounted by the damper manufacturer in their factory. Each damper shall be cycle tested at the factory prior to shipment.

DIMENSIONAL INFORMATION

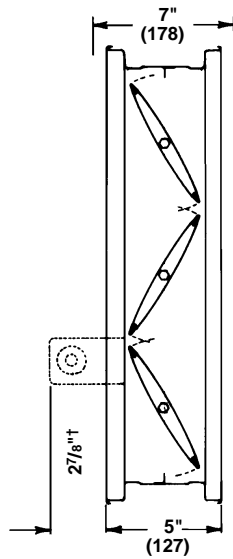

**OPPOSED
BLADE**

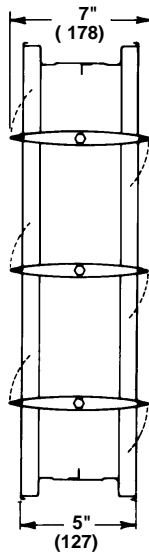

**PARALLEL
BLADE**

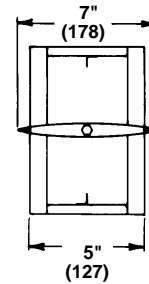

Low profile frame
illustrated is typical for
units under 12" (305) high.



Koch Filter Corporation
Filtration Products Crafted with Pride

Multi-Pleat Elite™

Self-Supporting Extended Surface Pleated Filter



High performance MERV 8 mechanical air filter media is self-supporting and requires no metal support grid downstream. No metal components means the filter is completely incinerable after use.

Exclusive vForm™ Pleating Technology maintains uniform pleat spacing in every filter. In addition, vForm™ Pleating Technology insures the same pleat configuration used for decades in our original Multi-Pleat products. Same aerodynamic v-shaped pleat design, same superior performance.

Sturdy, moisture-resistant, beverage board perimeter frame and cross-braces provide structural integrity even in difficult operating conditions.

The media used in the Multi-Pleat Elite is extraordinarily resilient and is engineered to endure the rigors of shipping, handling, installation and operation.



Multi-Pleat Elite earns the Koch Green Icon for one or more following categories: Earns LEED Points, Reduces Energy Costs, Extends Filter Lifecycles, Conserves Resources, and Improves Indoor Environmental Quality.

Features:

- Exclusive vForm™ Pleating Technology
- MERV 8 performance rating
- Self-supporting pleats requires no metal reinforcement
- Low resistance to airflow reduces energy costs
- Moisture-resistant beverage board frame
- Completely incinerable

Koch Filter Corporation...Durable. Reliable. Versatile.

Bulletin No. K-MPE10



Koch Filter Corporation
 Filtration Products Crafted with Pride

Multi-Pleat Elite Technical Data

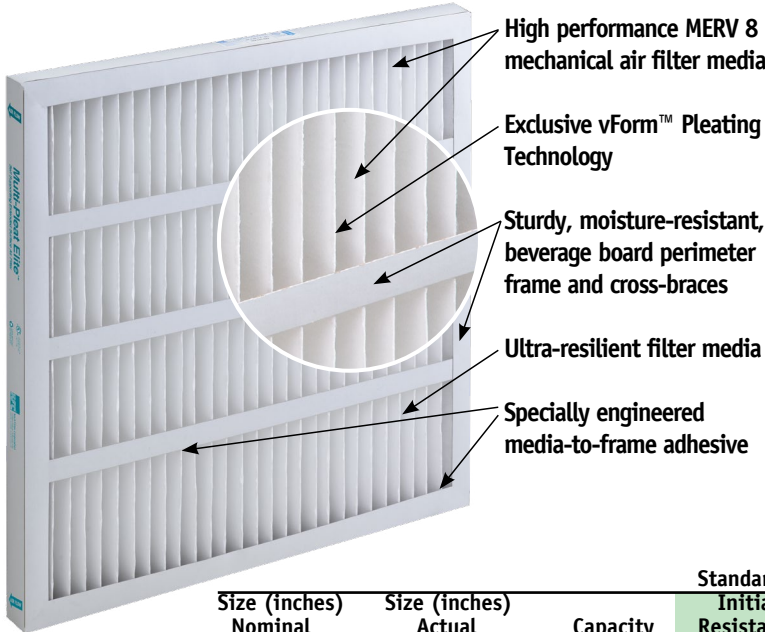

Initial Resistance vs. Filter Face Velocity

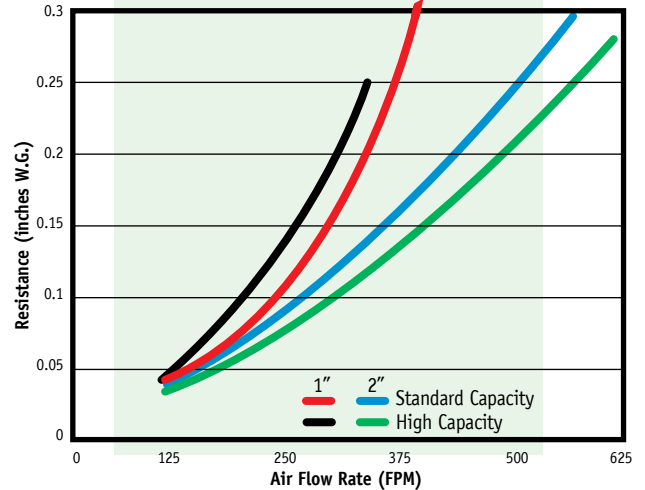

Additional Multi-Pleat Elite Product Information
 ASHRAE Test Standard 52.2-2007.
 Recommended maximum continuous operational temperature is 150° F (93° C).
 Multi-Pleat Elite filters are classified as Underwriter's Laboratories Class 2 according to U.L. Standard 900.

Size (inches) Nominal W x H x D	Size (inches) Actual W x H x D	Capacity (CFM)	Standard Capacity Elite		High Capacity Elite	
			Initial Resistance (in. W.G.)	Media Area (Sq. Ft.)	Initial Resistance (in. W.G.)	Media Area (Sq. Ft.)
12 x 24 x 1	11 ³ / ₈ x 23 ³ / ₈ x 3 ³ / ₄	600	0.29	3.3	0.20	3.8
14 x 20 x 1	13 ¹ / ₂ x 19 ¹ / ₂ x 3 ³ / ₄	590	0.29	3.4	0.20	3.8
14 x 25 x 1	13 ¹ / ₂ x 24 ¹ / ₂ x 3 ³ / ₄	730	0.29	4.3	0.20	4.8
15 x 20 x 1	14 ¹ / ₂ x 19 ¹ / ₂ x 3 ³ / ₄	630	0.29	3.6	0.20	4.1
16 x 20 x 1	15 ¹ / ₂ x 19 ¹ / ₂ x 3 ³ / ₄	670	0.29	3.8	0.20	4.3
16 x 24 x 1	15 ¹ / ₂ x 23 ³ / ₈ x 3 ³ / ₄	800	0.29	4.6	0.20	5.2
16 x 25 x 1	15 ¹ / ₂ x 24 ¹ / ₂ x 3 ³ / ₄	840	0.29	4.8	0.20	5.4
20 x 20 x 1	19 ¹ / ₂ x 19 ¹ / ₂ x 3 ³ / ₄	840	0.29	4.7	0.20	5.4
20 x 24 x 1	19 ¹ / ₂ x 23 ³ / ₈ x 3 ³ / ₄	1000	0.29	5.7	0.20	6.5
20 x 25 x 1	19 ¹ / ₂ x 24 ¹ / ₂ x 3 ³ / ₄	1050	0.29	6.0	0.20	6.8
24 x 24 x 1	23 ³ / ₈ x 23 ³ / ₈ x 3 ³ / ₄	1200	0.29	7.1	0.20	8.1
12 x 24 x 2	11 ³ / ₈ x 23 ³ / ₈ x 1 ³ / ₄	1000	0.26	5.4	0.20	7.8
14 x 20 x 2	13 ¹ / ₂ x 19 ¹ / ₂ x 1 ³ / ₄	980	0.26	5.5	0.20	7.9
14 x 25 x 2	13 ¹ / ₂ x 24 ¹ / ₂ x 1 ³ / ₄	1215	0.26	6.9	0.20	9.9
15 x 20 x 2	14 ¹ / ₂ x 19 ¹ / ₂ x 1 ³ / ₄	1050	0.26	6.0	0.20	8.4
16 x 20 x 2	15 ¹ / ₂ x 19 ¹ / ₂ x 1 ³ / ₄	1115	0.26	6.5	0.20	8.8
16 x 24 x 2	15 ¹ / ₂ x 23 ³ / ₈ x 1 ³ / ₄	1340	0.26	7.8	0.20	10.6
16 x 25 x 2	15 ¹ / ₂ x 24 ¹ / ₂ x 1 ³ / ₄	1400	0.26	8.1	0.20	11.0
18 x 24 x 2	17 ¹ / ₂ x 23 ³ / ₈ x 1 ³ / ₄	1500	0.26	8.4	0.20	12.3
20 x 20 x 2	19 ¹ / ₂ x 19 ¹ / ₂ x 1 ³ / ₄	1400	0.26	8.0	0.20	11.1
20 x 24 x 2	19 ¹ / ₂ x 23 ³ / ₈ x 1 ³ / ₄	1675	0.26	9.6	0.20	13.4
20 x 25 x 2	19 ¹ / ₂ x 24 ¹ / ₂ x 1 ³ / ₄	1740	0.26	10.0	0.20	14.0
24 x 24 x 2	23 ³ / ₈ x 23 ³ / ₈ x 1 ³ / ₄	2000	0.26	11.4	0.20	16.2
25 x 25 x 2	24 ¹ / ₂ x 24 ¹ / ₂ x 1 ³ / ₄	2170	0.26	12.5	0.20	17.4

Corporate Offices

P.O. Box 3186 • 625 West Hill Street (40208)
 Louisville, KY 40201 • 502.634.4796
 Fax: 502.637.2280 • E mail: info@kochfilter.com
 www.kochfilter.com



Look for the Koch Green icon! Whenever you see the Koch Green icon, we are identifying a product that meets or exceeds our criteria in one or more of the following categories: **Earns LEED Points, Reduces Energy Costs, Extends Filter Lifecycles, Conserves Resources, and Improves Indoor Environmental Quality.**



Series
2000

Magnehelic® Differential Pressure Gages

Indicate Positive, Negative or Differential, Accurate within 2%

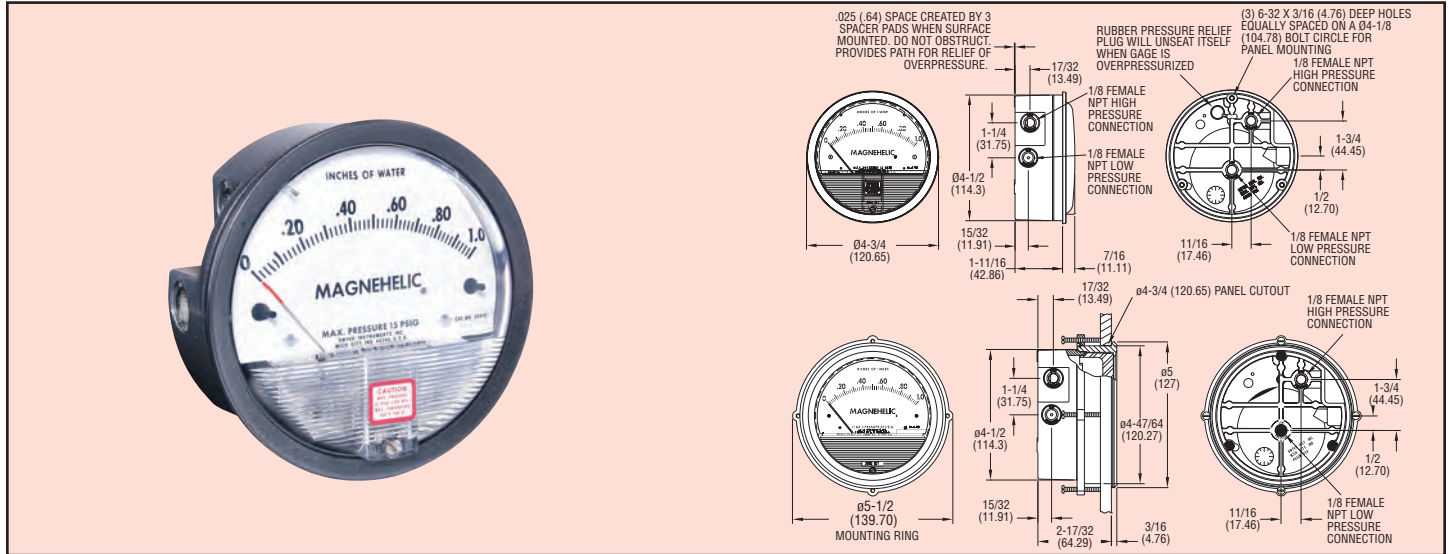

Select the Dwyer® Magnehelic® gage for high accuracy – guaranteed within 2% of full-scale – and for the wide choice of 81 models available to suit your needs precisely. Using Dwyer's simple, frictionless Magnehelic® gage movement, it quickly indicates low air or non-corrosive gas pressures – either positive, negative (vacuum) or differential. The design resists shock, vibration and over-pressures. No manometer fluid to evaporate, freeze or cause toxic or leveling problems. It's inexpensive, too.

The Magnehelic® gage is the industry standard to measure fan and blower pressures, filter resistance, air velocity, furnace draft, pressure drop across orifice plates, liquid levels with bubbler systems and pressures in fluid amplifier or fluidic systems. It also checks gas-air ratio controls and automatic valves, and monitors blood and respiratory pressures in medical care equipment.

Mounting

A single case size is used for most models of Magnehelic® gages. They can be flush or surface mounted with standard hardware supplied. Although calibrated for vertical position, many ranges above 1" may be used at any angle by simply re-zeroing. However, for maximum accuracy, they must be calibrated in the same position in which they are used. These characteristics make Magnehelic® gages ideal for both stationary and portable applications. A 4-9/16" hole is required for flush panel mounting. Complete mounting and connection fittings, plus instructions, are furnished with each instrument. See pages 6 and 7 for more information on mounting accessories.



Flush, Surface or Pipe Mounted



Enclosure Mounted

SPECIFICATIONS

Service: Air and non-combustible, compatible gases (natural gas option available).
Note: May be used with hydrogen. Order a Buna-N diaphragm. Pressures must be less than 35 psi.

Wetted Materials: Consult factory.

Coating: Die cast aluminum case and bezel, with acrylic cover. Exterior finish is coated gray to withstand 168 hour salt spray corrosion test.

Accuracy: ±2% of FS (±3% on -0, -100 Pa, -125 Pa, 10MM and ±4% on -00, -60 Pa, -6MM ranges), throughout range at 70°F (21.1°C).

Pressure Limits: -20 in Hg to 15 psig† (-0.677 to 1.034 bar); MP option: 35 psig (2.41 bar); HP option: 80 psig (5.52 bar).

Overpressure: Relief plug opens at approximately 25 psig (1.72 bar), standard gages only. See Overpressure Protection Note on next page.

Temperature Limits: 20 to 140°F*

(-6.67 to 60°C). -20°F (-28°C) with low temperature option.

Size: 4" (101.6 mm) diameter dial face.

Mounting Orientation: Diaphragm in vertical position. Consult factory for other position orientations.

Process Connections: 1/8" female NPT duplicate high and low pressure taps - one pair side and one pair back.

Weight: 1 lb 2 oz (510 g), MP & HP 2 lb 2 oz (963 g).

Standard Accessories: Two 1/8" NPT plugs for duplicate pressure taps, two 1/8" pipe thread to rubber tubing adapter, and three flush mounting adapters with screws. (Mounting and snap ring retainer substituted for three adapters in MP & HP gage accessories.)

Agency Approval: RoHS. **Note:** -SP models not RoHS approved.

†For applications with high cycle rate within gage total pressure rating, next higher rating is recommended. See Medium and High pressure options at lower left.

ACCESSORIES



Model A-432 Portable Kit

Combine carrying case with any Magnehelic® gage of standard range, except high pressure connection. Includes 9 ft (2.7 m) of 3/16" ID rubber tubing, standhanger bracket and terminal tube with holder.

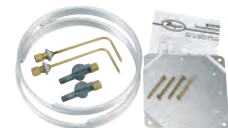

Model A-605 Air Filter Gage Accessory Kit

Adapts any standard Magnehelic® gage for use as an air filter gage. Includes aluminum surface mounting bracket with screws, two 5 ft (1.5 m) lengths of 1/4" aluminum tubing two static pressure tips and two molded plastic vent valves, integral compression fittings on both tips and valves.

A-605B Air Filter Gage Accessory Kit, Air filter kit with two plastic open/close valves, two 4" steel static tips, plastic tubing and mounting flange

A-605C Air Filter Gage Accessory Kit, Air filter kit with two plastic open/close valves, two plastic static tips, plastic tubing and mounting flange



Box mount, die cast aluminum with built-in junction box and sturdy mounting lugs. Medium base socket, 1/2" or 3/4" NPS hub size and a variety of globes. incandescent lamp A21 for 100 Series, PS25 for 200 Series. Lamp not supplied.

Color: Natural

Weight: 2.9 lbs

Project:

Type:

Prepared By:

Date:

Lamp Info

Type	A21
Watts	150.00W
Shape/Size	N/A
Base	N/A
ANSI	N/A
Hours	N/A
Lamp Lumens	N/A
Efficacy	N/A

Ballast Info

Type	N/A
120V	N/A
208V	N/A
240V	N/A
277V	N/A
Input Watts	0.00W

Technical Specifications

Listings

UL Listed:

Suitable for wet locations. Suitable for use in dwellings. Suitable for use with 90°C supply wiring. Complies with UL Standard 1598. For non-hazardous locations where the lamp, socket and wiring require protection from rain, corrosive fumes, non-combustible dusts, moisture, non-explosive vapors and gases. For lamp base up installation only when outdoors.

Construction

Globes:

Supplied with clear thermal shock resistant soda lime glass unless otherwise stated. Colored and white glass globes available. Unbreakable Permaglobes available in clear and in color.

Die Cast Guard:

Supplied with one piece die cast guard with set screw

Electrical

Maximum Watts:

150 watts

Colored Globe Maximum Watts:

100 watts

Input Voltage:

120V

Other

Buy American Act Compliance:

RAB values USA manufacturing! Upon request, RAB may be able to manufacture this product to be compliant with the Buy American Act (BAA). Please contact customer service to request a quote for the product to be made BAA compliant.

Dimensions

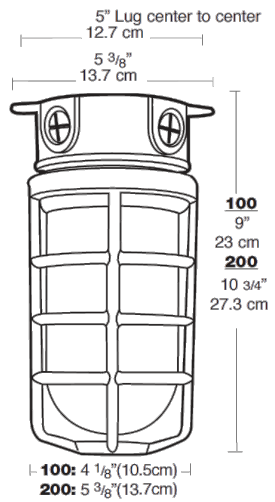

Features

- All stainless steel hardware
- Close-up plugs allow Phillips or slotted screwdrivers for easy installation
- Junction box with sturdy mounting lugs
- UL Listed for use with 90°C supply wiring OK for use in dwellings and wet locations
- High temperature silicone internal gaskets
- Premium porcelain socket with 150C 8" long leads



A19 REPLACEMENT : E26 & GU24 BASE

DESCRIPTION

LED A-Line Replacement Lamps directly replace incandescent A lamps at a fraction of the energy cost.

FEATURES

- Direct replacement for 40W, 60W, 75W, or 100W incandescent A-lamps
- 240° beam angle is ideal for table lamps, wall sconces, and luminous globe fixtures
- 80% more efficient and 30x longer life than standard incandescent
- Shatter-resistant plastic housing for reduced risk of injury and breakage
- Dimmable models compatible with a wide array of dimmers
- ANSI construction compliant
- Not for use with electronic timers, photocells, or motion/occupancy sensors

WARRANTY

- 5 year limited warranty; see eiko.com for warranty details

APPLICATIONS

- Restaurants & Hospitality
- Retail
- Residential
- Accent/Display Lighting
- Healthcare



A19 E26



A19 GU24



PERFORMANCE	Power Consumption	5.5W	8W	11W	13W
	Lumens	450	800	1,100	1,600
	Efficacy (LPW)	82	100	100	123
	CRI		80+		
	Beam		240°		
	CCT		2700K/3000K/4000K/5000K		
	Life (L70)				
ELECTRICAL	Power Factor		>0.7		
	Input Voltage		120V		
CONSTRUCTION	Operating Temperature		-4°F to 104°F (-20°C to 40°C)		
	Base		E26/GU24		
LISTINGS	Certification(s)		ENERGY STAR® Rated; cULus Classified		
	Material Usage		RoHS Compliant; no mercury or lead		
	Environment		Suitable for damp locations; Enclosed fixture rated		

PERFORMANCE SUMMARY

A19 MEDIUM BASE (E26):

Order Code	Item #	Lumens	Watts	LPW	CCT	CRI	Beam	MOL	MOD	Life/Hours	Replaces Incan.	ES
11067	LED5.5WA19/OMN/827-DIM-B	450	5.5W	82	2700K	80+	240°	4.25"	2.36"	25,000	40W A19	★
11068	LED5.5WA19/OMN/830-DIM-B	450	5.5W	82	3000K	80+	240°	4.25"	2.36"	25,000	40W A19	★
11069	LED5.5WA19/OMN/840-DIM-B	450	5.5W	82	4000K	80+	240°	4.25"	2.36"	25,000	40W A19	★
11070	LED8WA19/OMN/827-B	800	8W	100	2700K	80+	240°	4.25"	2.36"	25,000	60W A19	★
11071	LED8WA19/OMN/830-B	800	8W	100	3000K	80+	240°	4.25"	2.36"	25,000	60W A19	★
11072	LED8WA19/OMN/840-B	800	8W	100	4000K	80+	240°	4.25"	2.36"	25,000	60W A19	★
11073	LED8WA19/OMN/850-B	800	8W	100	5000K	80+	240°	4.25"	2.36"	25,000	60W A19	★
11074	LED8WA19/OMN/827-DIM-B	800	8W	100	2700K	80+	240°	4.25"	2.36"	25,000	60W A19	★
11075	LED8WA19/OMN/830-DIM-B	800	8W	100	3000K	80+	240°	4.25"	2.36"	25,000	60W A19	★
11076	LED8WA19/OMN/840-DIM-B	800	8W	100	4000K	80+	240°	4.25"	2.36"	25,000	60W A19	★
11077	LED8WA19/OMN/850-DIM-B	800	8W	100	5000K	80+	240°	4.25"	2.36"	25,000	60W A19	★
11081	LED11WA19/OMN/827-DIM-B	1,100	11W	100	2700K	80+	240°	4.25"	2.36"	25,000	75W A19	★
11082	LED11WA19/OMN/830-DIM-B	1,100	11W	100	3000K	80+	240°	4.25"	2.36"	25,000	75W A19	★
11083	LED11WA19/OMN/840-DIM-B	1,100	11W	100	4000K	80+	240°	4.25"	2.36"	25,000	75W A19	★
11084	LED11WA19/OMN/850-DIM-B	1,100	11W	100	5000K	80+	240°	4.25"	2.36"	25,000	75W A19	★
11088	LED13WA19/OMN/827-DIM-B	1,600	13W	123	2700K	80+	240°	4.6"	2.36"	25,000	100W A19	★
11089	LED13WA19/OMN/830-DIM-B	1,600	13W	123	3000K	80+	240°	4.6"	2.36"	25,000	100W A19	★
11090	LED13WA19/OMN/840-DIM-B	1,600	13W	123	4000K	80+	240°	4.6"	2.36"	25,000	100W A19	★
11091	LED13WA19/OMN/850-DIM-B	1,600	13W	123	5000K	80+	240°	4.6"	2.36"	25,000	100W A19	★

A19 GU24 BASE:

Order Code	Item #	Lumens	Watts	LPW	CCT	CRI	Beam	MOL	MOD	Life/Hours	Replaces Incan.	ES
11078	LED8WA19/OMN/827-GU24-DIM-B	800	8W	100	2700K	80+	240°	4.25"	2.36"	25,000	60W A19	★
11079	LED8WA19/OMN/830-GU24-DIM-B	800	8W	100	3000K	80+	240°	4.25"	2.36"	25,000	60W A19	★
11080	LED8WA19/OMN/840-GU24-DIM-B	800	8W	100	4000K	80+	240°	4.25"	2.36"	25,000	60W A19	★
11085	LED11WA19/OMN/827-GU24-DIM-B	1,100	11W	100	2700K	80+	240°	4.25"	2.36"	25,000	75W A19	★
11086	LED11WA19/OMN/830-GU24-DIM-B	1,100	11W	100	3000K	80+	240°	4.25"	2.36"	25,000	75W A19	★
11087	LED11WA19/OMN/840-GU24-DIM-B	1,100	11W	100	4000K	80+	240°	4.25"	2.36"	25,000	75W A19	★

NOTE: Use order code when ordering. ★ENERGY STAR® Rated

DIMENSIONS



Allegis Product Detail

1-866-378-7550

Allegis Part Number: 265076-00P

Description: NON-LOCKING VENTILATION L-HANDLE

Print

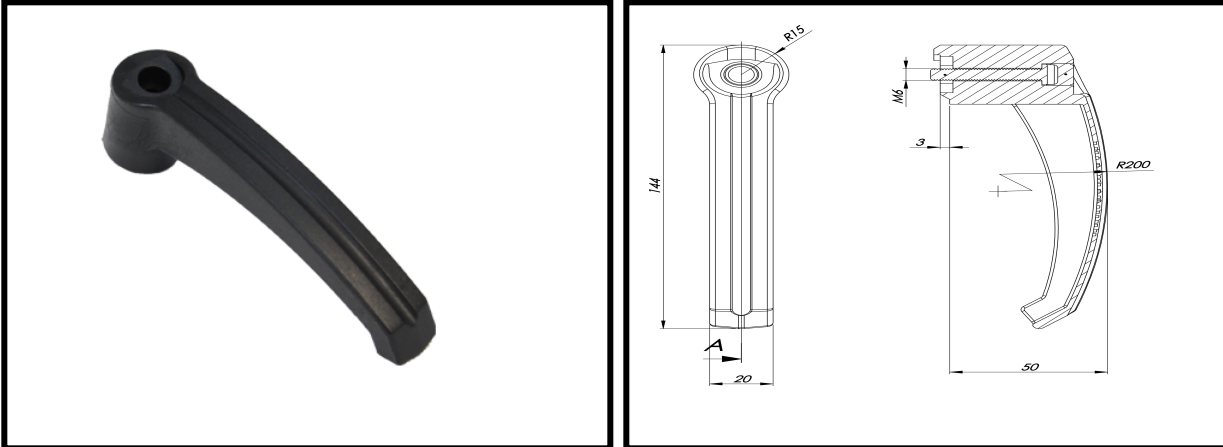

- Designed for the HVAC industry
- Can be used as part of a complete latching system (KlimaFlex)
- Nylon 6 construction
- Supplied with screw and plastic cover plug
- Black finish
- **Individually Packaged**

Accessories

699 INSTRUMENT TEST HOLES

These test holes make it easy and economical to provide openings for Pitot tubes and other test instruments, to measure static pressures and air velocities. The hole is sealed off with a heavy screw cap and gasket. Unless otherwise specified a flat gasket is supplied to prevent air leakage around the base. For an extra charge, special gaskets are available to adapt these test holes to round duct. *Weight per 100, 36 lbs.*

These test holes are now available in two sizes: #699 with a total height of 1⁵/₈" will accommodate one inch of insulation, #699-2 with a total height of 2⁵/₈" is made for two inches of insulation. *Weight per 100, 48 lbs.*

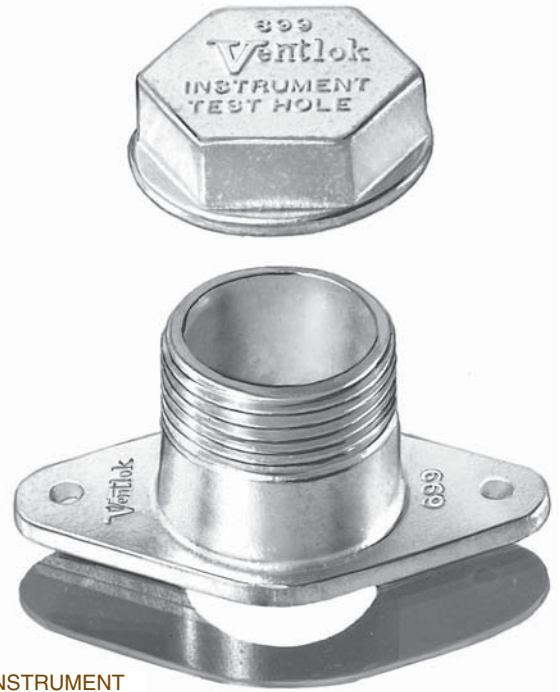

699 INSTRUMENT
TEST HOLE



Startup Checklist

Product Type: Semi-Custom Air Handling Units

Unit Tags: Various

 BY JOHNSON CONTROLS	AIR HANDLING UNITS
START-UP CHECKLIST	Supersedes: 100.00-CL1 (909) Form 100.00-CL1 (313)

AIR HANDLER START-UP CHECKLIST

OFFICE LOCATION _____	UNIT TAG # _____
QUALIFIED TECHNICIAN _____	UNIT MODEL # _____
JOB NAME _____	UNIT SERIAL # _____
YORK JOB ID OR CONTRACT # _____	START DATE _____
JOB SITE LOCATION _____	
JOB SITE CONTACT AND PHONE # _____	

IMPORTANT SAFETY REQUIREMENT: FOLLOW THE LATEST "LOCK OUT TAG OUT" PROCEDURE.

PRE START-UP

GENERAL UNIT INSPECTION

Identify and perform appropriate “lock out/tag out” and safety rules. For details on points below see appropriate section of the Installation Instruction provided with each air handler.

For VFD equipped air handlers, refer to the VFD forms for additional requirements.



Serious damage to the AHU and/or system is eminent if the AHU is operated under any of the following conditions:

- ***Without proper control of dampers.***
- ***With smoke dampers closed.***
- ***During a fire alarm or smoke purge test.***
- ***Any airflow restriction greater than normal.***

Solution	AH Units	Form	102.20-OM1	Air Modulator	VFD Quick Start	Form	100.42-NO1
Custom	AH Units	Form	100.31-NOM1				

<input type="checkbox"/> Equipment received as ordered.	<input type="checkbox"/> Unit installed with proper clearances.
<input type="checkbox"/> Unit checked for damage to interior and exterior.	<input type="checkbox"/> Visually inspect roof curb for tight seal around unit.
<input type="checkbox"/> Unit installed on flat and level surface. Outdoor unit mounted within roof slope limitations where applicable.	<input type="checkbox"/> All penetrations MUST be sealed. All conduits MUST be sealed internally.
<input type="checkbox"/> Terminal screws and wiring connections secure in control, electric and Air Modulator panels.	<input type="checkbox"/> Clean air filters installed properly and secured.
<input type="checkbox"/> Air hoods installed properly.	<input type="checkbox"/> Filter gauge set to zero.
<input type="checkbox"/> Condensate drain properly trapped.	<input type="checkbox"/> All field wiring complete and inspected.
<input type="checkbox"/> All wiring and tubing connections made at shipping splits.	<input type="checkbox"/> All shipping splits sealed and secured properly.
<input type="checkbox"/> All field piping connections complete.	<input type="checkbox"/> Pipe chase floor sealed at penetrations.
<input type="checkbox"/> All shipped loose parts installed.	<input type="checkbox"/> All shipping bolts and other material have been removed. (Fan, VIFB, Energy Recovery Wheel, Damper).
<input type="checkbox"/> Installer has cleaned out interior.	<input type="checkbox"/> Damper linkage is tight and in correct "power off" position.
<input type="checkbox"/> Verify all plug-ins and wire connections are tight on UV equipment.	<input type="checkbox"/> Controls installation complete.
<input type="checkbox"/> Verify Energy Recovery Wheel turns freely and wheel segments are fully engaged.	<input type="checkbox"/> Verify all spacers removed from door edges.
<input type="checkbox"/> Verify all ductwork is complete and available for full air flow.	<input type="checkbox"/> Verify correct piping of split system. Reference Section 2 of Solution IOM & Split System Application Guide (050.40-ES3).

Full Unit Startup Not Included, Only VFD

FAN INSPECTION	
<input type="checkbox"/> Check bearings and locking collars for properly tightened setscrews, bolts and nuts.	<input type="checkbox"/> Fan wheel properly aligned, tight on shaft and freely moving.
<input type="checkbox"/> Sheaves properly aligned and tight on shaft.	<input type="checkbox"/> Check fan base isolators and thrust restraints for proper adjustment. Note: Do not remove functional bolts from seismic isolators.
<input type="checkbox"/> Belt tension adjusted properly per drive pkg. label on fan.	
<input type="checkbox"/> Check fan alignment with unit discharge. Adjust with isolation.	<input type="checkbox"/> Fan bearings have been re-lubricated properly.

START-UP

PERFORM THE FOLLOWING STEPS IN ORDER:

Refer to safety standards. Ensure all door latches are secured before starting.

<input type="checkbox"/> 1. With all Electric Power off, all disconnect switches open and fuses removed, check each circuit with an Ohm meter to ground observing no continuity. Reinstall fuses.	<input type="checkbox"/> 8. Immediately check current draw of each leg of each motor.
<input type="checkbox"/> 2. Energize power to the unit disconnect switch.	<input type="checkbox"/> 9. VFD, refer to manufactures start up guide
<input type="checkbox"/> 3. Verify correct voltage, phase and cycles.	<input type="checkbox"/> 10. Check doors and latches for air leaks.
<input type="checkbox"/> 4. Energize fan motor(s) briefly (bump) and check for correct fan rotation.	<input type="checkbox"/> 11. Check for obvious audible leaks.
<input type="checkbox"/> 5. Check operation of dampers. Insure unit will not operate with all dampers closed.	<input type="checkbox"/> 12. Apply steam to cold coils slowly to prevent damage.
<input type="checkbox"/> 6. Energize fan motor(s). Observe fan(s) for smooth operation.	<input type="checkbox"/> 13. Observe energy recovery wheel rotation is correct.
<input type="checkbox"/> 7. Check motor nameplate Full Load Amp rating.	<input type="checkbox"/> 14. Purge on energy recovery wheel is set to specification.

RECORD DATA

POWER SUPPLY: Unit Nameplate V___ PH___ CYC, ___ Verify V ___/___/___

DATA

	SUPPLY FAN MOTOR	EXHAUST/RETURN FAN MOTOR
Nameplate	Volts _____ Amps _____	Volts _____ Amps _____
Run Amps	_____ / _____ / _____	_____ / _____ / _____
Catalog Number	_____	_____
Spec Number	_____	_____
Horse Power	_____	_____
RPM	Nameplate _____ Actual _____	Nameplate _____ Actual _____
Frame size	_____	_____
Service Factor	_____	_____
Jump (Skip) Frequencies	_____ / _____ / _____	_____ / _____ / _____
	SUPPLY FAN	EXHAUST/RETURN FAN
Manufacture Name	_____	_____
Type or Model Number	_____	_____
Code or Shop Order Number	_____	_____
Serial Number	_____	_____
	SUPPLY FAN DRIVE KIT	EXHAUST/RETURN FAN DRIVE KIT
Belts (Qty & ID#)	_____	_____
Belt Tension	Tag _____ Actual _____	Tag _____ Actual _____
Fan RPM (DN)	Tag _____ Actual _____	Tag _____ Actual _____

OTHER UTILITIES

Steam Pressure	Heating Coils ___ PSI,	Humidifier ___ PSI
Hot Water Pressure/Temp.	Supply ___ PSI, ___ °F,	Return ___ PSI, ___ °F
Chilled Water Pressure/Temp.	Supply ___ PSI, ___ °F,	Return ___ PSI, ___ °F
Potable Water Pressure	___ PSI,	Pneumatic Air Pressure ___ PSI

Full Unit Startup Not Included, Only VFD

MAINTENANCE

Upon completion of start-up the customer assumes responsibility for periodic maintenance of this equipment in order to continue warranty. Refer to the Installation Operation and Maintenance Manual (Form 102.20-OM1).

Customer's agent signature: _____ **Date:** _____





Authorized Start-Up on AYK580 Relabeled VFDs

This form is to be used by factory authorized personnel only for the JCI AYK580 drive product warranty registration as part of the Authorized Start-Up program. This form must be completed in it's entirety and kept on file within 10 Working Days from start-up at the JCI Local Sales Branch for possible future Technical Support. For JCI AYK580 drives ONLY

* All procedures and requirements as documented in the user Manuals for the product you are commissioning must be followed.

End User installation site				Start-Up Date:	
Company Name		Contact Name		Contact Phone	
Street Address		City		State	Zip Code

Purchased From				Supplier Type:	
Company Name		City	State	Contact Name	
				Contact Phone	

Drive Product Information		
Model Number (Type Code)	Serial Number	Software Revision code

Application Information			
Industry type	Application type	Drive control mode	Operation mode

Motor Information				
Select motor type	AC motor			
Motor HP:	Voltage:	RPM:	FLA:	Freq:

Installation Checks - Mechanical			
Mechanical Installation	<input type="checkbox"/>	Control (I/O, Feedback)	<input type="checkbox"/>
Cable Connections	<input type="checkbox"/>	Ambient Temperature	
Proper Grounding	<input type="checkbox"/>	Drive Unit cooling / Air flow	<input type="checkbox"/>
Input Fuses	<input type="checkbox"/>	Motor disengaged	<input type="checkbox"/>
Wire run to/from motor	<input type="checkbox"/>	Safe to operate machine	<input type="checkbox"/>
Motor cable length	<input type="checkbox"/>	AutoTune completed	<input type="checkbox"/>

Installation Checks - Electrical		Readings Not Required for AYK580 Start-Up	
Drive disconnected - Megger Cable/Motor:		T1-PE = NA	T3-PE = NA
Megger test voltage = Megger Test NA		T2-PE = NA	
Optional Measurements	L1-L2=	*Optional Measurements*	L1 =
Input Voltage @ Base Spd	L2-L3=	Input Current @ Base Spd	L2 =
	L3-L1=		L3 =
Optional Measurements	T1-T2=	*Optional Measurements*	T1 =
Output Voltage @ Base Spd	T2-T3=	Output Current @ Base Spd	T2 =
	T3-T1=		T3 =

Additional Comments: **PWM Meter Required for Output VFD Voltage Readings (Recommended Meter Fluke 87V)**

--	--

Performed by:	Registered E-mail:

By submittal of this form you commit that all information provided is accurate to the best of your ability, provided to the customer, and the requirements as listed here and in the product user Manual have been completed.



Warranty Information

Product Type: Semi-Custom Air Handling Units

Unit Tags: Various

**OPTIONAL 2 YEAR PARTS & LABOR LIMITED WARRANTY
YORK® SOLUTION™ XTO/XTI
JOHNSON CONTROLS**

PRODUCT TYPE: YORK® SOLUTION™ XTO/XTI
YORK CONTRACT NO.:
UNIT MODEL NUMBER:
UNIT SERIAL NUMBER:
UNIT TAG ID:
UNIT LOCATION:

STARTUP DATE:
SHIPPING DATE:

PROJECT NAME:
INSTALLATION
ADDRESS:

LIMITED WARRANTY

Subject to the terms, conditions, exclusions, and other limitations set forth in the Standard Limited Warranty for Engineered Systems Equipment (50.05-NM2), when properly endorsed, this protection plan between Johnson Controls, Inc. (“Seller”) and the undersigned Customer (“Buyer”) warrants that that each new Engineered Systems Equipment manufactured by Seller and materials, or installation or start-up services performed by Johnson Controls in connection therewith, are free from defects in material and workmanship for thirty (30) months from the date of shipment from Seller’s facility or twenty-four (24) months from startup, whichever occurs first. When properly endorsed, this protection plan between the Seller and Buyer, warrants, to the customer named herein, labor for the entire air handling unit. Labor repairs must be performed in accordance with instructions issued by Johnson Controls.

THIS WARRANTY IS EXCLUSIVE AND IN LIEU OF ALL OTHER WARRANTIES AND LIABILITIES, EXPRESS OR IMPLIED IN LAW OR IN FACT, INCLUDING, WITHOUT LIMITATION, THE WARRANTIES OF MERCHANTABILITY AND FITNESS FOR A PARTICULAR PURPOSE. THE WARRANTIES CONTAINED HEREIN SET FORTH BUYER’S SOLE AND EXCLUSIVE REMEDY IN THE EVENT OF A DEFECT IN WORKMANSHIP OR MATERIALS. IN NO EVENT SHALL JOHNSON CONTROLS’ LIABILITY FOR DIRECT OR COMPENSATORY DAMAGES EXCEED THE PAYMENTS RECEIVED BY JOHNSON CONTROLS FROM BUYER FOR THE MATERIALS OR EQUIPMENT INVOLVED. NOR SHALL JOHNSON CONTROLS BE LIABLE FOR ANY SPECIAL, INCIDENTAL, OR CONSEQUENTIAL DAMAGES. THESE LIMITATIONS ON LIABILITY AND DAMAGES SHALL APPLY UNDER ALL THEORIES OF LIABILITY OR CAUSES OF ACTION, INCLUDING, BUT NOT LIMITED TO, CONTRACT, WARRANTY, TORT (INCLUDING NEGLIGENCE) OR STRICT LIABILITY. THE ABOVE LIMITATIONS SHALL INURE TO THE BENEFIT OF JOHNSON CONTROLS’ SUPPLIERS AND SUBCONTRACTORS.

Notification of defect and any warranty claim must be made in writing, postage paid, with a brief written description of the problem to Buyer’s local Johnson Controls’ sales/service office. Nothing herein is intended to provide warranty coverage to lessees or anyone other than Buyer and no third-parties are intended to be beneficiaries of this warranty.

BRANCH SERVICE OFFICE:

OFFERED BY: _____
Johnson Controls Selling Representative Print/Sign Date

APPROVED BY: _____
Johnson Controls Branch Manager or other authorized individual Print/Sign Date

ACCEPTED BY: _____
Customer Signature Date



Long Term Storage Section

Product Type: Semi-Custom Air Handling Units

Unit Tags: Various

JCI NOTE: LONG TERM STORAGE IS REQUIRED IF EQUIPMENT IS NOT STARTED UP WITHIN 6 MONTHS OF SHIPMENT - MUST BE PURCHASED SEPARATELY IF REQUIRED

 BY JOHNSON CONTROLS	LONG-TERM STORAGE PERIODIC CHECKLIST AND LOGS AIR HANDLING UNITS	
SERVICE POLICY & PROCEDURES	Supersedes: 50.20-CL3 (507)	Form 50.20-CL3 (909)

Contract No.	_____	Date Delivered	_____
Job Name	_____	Date of Storage Prep.	_____
Serial No	_____	Condition of Unit Delivered	_____
Unit Model No	_____	Explain:	_____
	_____		_____
	_____		_____
	_____		_____

Failure to comply with these requirements will render any written or implied Johnson Controls warranty null and void.

I. Supplementary Documentation

The following documentation is required to FULLY COMPLY with the long term storage requirements.

- A. Long-Term Storage Requirements - GENERAL (refer to Form 50.20-NM1).
- B. Long-Term Storage Requirement - LONG -TERM STORAGE REQUIREMENT FIELD PREPARATION, AIR HANDLING UNITS (refer to Form 50.20-NM3).

II. Checks

1.0 Monthly Checks

- 1.1 Visually inspect Air Handler for damage.
 - 1.1.1 Motors/Drives - The motors and sheaves should be inspected externally for evidence of damage to the protective covering. An inspection is necessary only if it is apparent that the control protection has been disturbed. If this is found, the motor should be re-protected by wrapping and tightly sealing the control with plastic and inserting a desiccant to absorb moisture.
- 1.2 Refrigerant Coils - Check holding charge pressure monthly to be sure that the pressure has not dropped. If pressure has dropped, the unit should be inspected for signs of visible damage which may have caused the loss of pressure. If pressure drops more than 2 psi, the unit should be pressure tested to locate the leak, the leak repaired, and the unit recharged with nitrogen to 5 psig pressure. Note this in the comments section of the monthly log sheet (see page 2 of this document).
- 1.3 Rotate fan shaft several revolutions by hand every month.

2.0 Quarterly Checks

- 2.1 Complete Assembly - The unit should be checked quarterly to see that no damage has occurred to the protective covering. Any apparent damage to the covering or units should be noted in the comments section of the quarterly log sheet (see page 3 of this document).
- 2.2 Grease bearings every three months. The greasing procedure is explained in the product service manual.

3.0 Semi Annual Checks

- 3.1 None

4.0 Annual Checks

- 4.1 Unwrap all electrical cabinets and install new Vapor Emitters (YORK P/N 026-37705-000); reseal.
- 4.2 Re-spray all exposed shafts and sheaves with anti-corrosion spray, YORK P/N 026-37707-007.

1.0 Monthly				
	Rotate Shafts	5 PSI Coil Pressure	Motor Belts & Drives Protected and Dry	Comments
Date				
Initial				
Date				
Initial				
Date				
Initial				
Date				
Initial				
Date				
Initial				
Date				
Initial				
Date				
Initial				
Date				
Initial				
Date				
Initial				
Date				
Initial				
Date				
Initial				
Date				
Initial				
Date				
Initial				
Date				
Initial				

2.0 Quarterly			
	Grease Bearings	Inspect Protective Covering	Comments
Date			
Initial			
Date			
Initial			
Date			
Initial			
Date			
Initial			

4.0 Annual			
	Install New Vapor Emitters	Re-spray Exposed Shafts and Sheaves	Comments
Date			
Initial			

JCI NOTE: LONG TERM STORAGE IS REQUIRED IF EQUIPMENT IS NOT STARTED UP WITHIN 6 MONTHS OF SHIPMENT - MUST BE PURCHASED SEPARATELY IF REQUIRED

 BY JOHNSON CONTROLS	LONG-TERM STORAGE REQUIREMENT - FIELD PREPARATION AIR HANDLING UNITS	
SERVICE POLICY & PROCEDURES	Supersedes 50.20-NM3 (307)	Form 50.20-NM3 (909)

Failure to comply with these requirements will render any written or implied YORK warranty null and void.

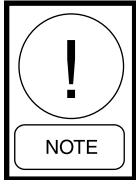

Upon completion of the long term storage period, the warranty commences:

- *Solution - 18 months parts only. (not to exceed 36 months from ship date with delayed start up).*
- *Custom - 18 months factory parts (not to exceed 18 months from ship date).*
- *Labor 12 months only w/ delayed start up.*

I. Supplementary Documentation

The following documentation is required to FULLY COMPLY with the Long-Term Storage requirements.

- A. Long-Term Storage Requirements – GENERAL (refer to Form 50.20-NM1)
- B. Long-Term Storage – PERIODIC CHECKLIST AND LOGS, AIR HANDLING UNITS (refer to Form 50.20-CL3).

II. Field Preparation for Long-Term Storage

A. GENERAL

1. Remove and dispose of shipping materials.
2. Perform a visual inspection of the equipment.

Indoor Units

It is Johnson Controls' intention that a shipping wrapper be applied to unpainted indoor units for protection from weather, road dirt, etc. during inland transit and that the wrapper be removed at the time of delivery to allow for a thorough inspection, both inside and out. Visible damage should be noted on the signed and dated bill of lading with a request that the carrier inspect the damage within 72 hrs of notification. The shipping wrapper must be removed and replaced with a tarp or similar protective covering. Any concealed damaged reported after 15 days will compromise a claim settlement. Inspection requests may be done by telephone or in person, but should be confirmed in writing. If assistance is needed with the claim process, contact your Johnson Controls Sales person.

Outdoor Units

Outdoor units are not fully wrapped. Exposed openings are covered for protection from weather, road dirt, etc. during inland transit. A thorough inspection, both inside and out, should be done at the time of delivery. Visible damage should be noted on the signed and dated bill of lading with a request that the carrier inspect the damage within 72 hrs of notification. Concealed damage must be reported within 15 days of delivery with a request that the carrier inspect the damage within 72 hrs of notification. Any concealed damaged reported after 15 days will compromise a claim settlement. Inspection requests may be done by telephone or in person, but should be confirmed in writing. If assistance is needed with the claim process, contact your Johnson Controls Sales person.

3. Touch up any paint that has worn or chipped off using paint supplied in ship loose items. Prepare the surface as required using a wire brush.
4. Verify that all ship loose items are present. Note any missing items on the Periodic Check List and Log Sheet (50.20-CL3).
5. Locate unit(s) so that passing traffic will not damage shafts, coil connections, damper linkages or unit panels.
6. Refrigerant coils must be evacuated and pre-charged with 5 PSIG nitrogen holding charge. DO NOT damage or disturb these coils and connections.
7. Water coils must have all inlet and outlet connections capped or closed tight to prevent foreign materials and liquids from gaining entrance during the storage period.

B. ELECTRICAL EQUIPMENT AND COMPONENTS

(Control Panels, Power Panels, Option Panels, Motors, etc.)

1. Electrical Equipment and Components shall not be stored or left in an outdoor environment.
2. Electrical Equipment and Components shall not be stored or left in a wet or damp environment. Components sealed in plastic shrink-wrap are not exempt from this requirement. Moisture will collect inside the plastic, resulting in corrosion of the cabinet, the electronic components and/or copper bus bars.
3. Cortec® spray (Part VpCL-248) shall be applied to all components in the motor terminal box. The spray shall be applied to all exposed areas of concern.
4. YORK Vapor Emitter(s) shall be installed inside each electrical and electronic components cabinet(s) to protect against corrosion. Openings in cabinets shall be taped closed to minimize air infiltration during the storage period. The quantity of emitters is determined by measuring the gross volume of the component space occupied. YORK Part Number 026-37705-000 will protect a volume up to 5 cubic feet. YORK Part Number 026-37706-000 will protect a volume up to 11 cubic ft. Both emitters have a service life of 12 months.
5. A Vapor Type Corrosion inhibitor must be installed in the following equipment and components:
 - a. Place one corrosion inhibitor, YORK part number 026-37706-000, inside the power panel.
 - b. Place one corrosion inhibitor, YORK part number 026-37705-000, inside the control panel.
 - c. Place one corrosion inhibitor, YORK part number 026-37705-000, inside each VFD panel.

C. MECHANICAL

1. Spray all exposed shafts and sheaves with anti-corrosion spray, YORK part number 026-37707-007.
2. Disconnect belts and wrap all motors and sheaves in plastic with a YORK vapor emitter, part number 026-37705-000.



CUSTOMER APPROVAL:

Customer Name: _____

Signature (*) _____

Date: _____