



Submittal

AMN Healthcare

12/30/2022

Contractor

Rogers-O'Brien Construction
11200 Richmond Ave Ste 110
Houston, Tx 77082

Project Manager

Genesis Arroyo
(469) 369-4652

Supplier

TDIndustries
13850 Diplomat Dr
Dallas, TX 75234
(214) 215-9349

Equipment

Price VAVs



Terminals Submittals

Job Name: AMN Healthcare Project
Job Location: Dallas, TX
Customer: TD Industries
Date Printed: 12/27/2022
Spec Section: 15 - HVAC

<input type="checkbox"/> No Exception Taken	<input checked="" type="checkbox"/> Furnish As Corrected	<input type="checkbox"/> Revise And Submit
<input type="checkbox"/> Rejected	<input type="checkbox"/> Submit Specific Item	
<input type="checkbox"/> Reviewed For Compliance With Performance Spec		
<small>This review was performed only for general conformance to design concept of the project and general compliance with information given in the contract documents. Modifications or comments made on the shop drawings during this review do not relieve contractor from compliance with the requirements of the plans and specifications. Contractor is responsible for: dimensions being confirmed and correlated at the jobsite, information that pertains solely to fabrication processes or to the means, methods, techniques, sequences, and procedures of construction, coordination of the work of all trades, and performing all work in a safe and satisfactory manner.</small>		
PURDY-MCGUIRE, INC. – MEP ENGINEERS 17300 N. Dallas Parkway, Suite 3000, Dallas, Texas 75248 Phone: (972) 239-5357 www.Purdy-McGuire.com		 Purdy-McGuire
Date: January 10, 2023	By: Jeremy Pendery	

Comments: 4th floor equipment missing in submittal.
--

Contact: 6029 W CAMPUS CIRCLE DRIVE
SUITE 100
IRVING, TX 75063



All-In-One
Detailed Submittal Schedule
Terminals

Tag	5-1	5-2	5-3	5-4
#	68	69	70	71
Qty	1	1	1	1
Model	SDV	SDV	SDV	SDV
Size 1	8	12	10	6
Max Primary (CFM)	310	1140	720	230
Min Primary (CFM)	62	228	144	46
Heat Min (CFM)	62	228	144	46
Terminal Liner	FF50	FF50	FF50	FF50
Sequence	2000	2000	2000	2000
Aux/Fan/Mix	0	0	0	0
Accessories 2	CLH	CLH	CRH	CRH
Accessories 6	DSW	DSW	DSW	DSW
Comments	8 Size 8	12 Size 12	10 Size 10	6 Size 6

Tag	5-5	5-6	5-7	5-8
#	72	73	74	75
Qty	1	1	1	1
Model	SDV	SDV	SDV	SDV
Size 1	8	6	6	10
Max Primary (CFM)	520	240	240	810
Min Primary (CFM)	104	48	48	162
Heat Min (CFM)	104	48	48	162
Terminal Liner	FF50	FF50	FF50	FF50
Sequence	2000	2000	2000	2000
Aux/Fan/Mix	0	0	0	0
Accessories 2	CLH	CRH	CLH	CLH
Accessories 6	DSW	DSW	DSW	DSW
Comments	8 Size 8	6 Size 6	6 Size 6	10 Size 10

Tag	5-9	5-10	5-11	5-12
#	76	77	78	79
Qty	1	1	1	1
Model	SDV	SDV	SDV	SDV
Size 1	6	8	8	8
Max Primary (CFM)	225	260	435	440
Min Primary (CFM)	45	52	87	88
Heat Min (CFM)	45	52	40	88
Terminal Liner	FF50	FF50	FF50	FF50
Sequence	2000	2000	2000	2000
Aux/Fan/Mix	0	0	0	0
Accessories 2	CRH	CLH	CRH	CLH
Accessories 6	DSW	DSW	DSW	DSW
Comments	6 Size 6	8 Size 8	8 Size 8	8 Size 8

Tag	5-13	5-14	5-15	5-16
#	80	81	82	83
Qty	1	1	1	1
Model	SDV	SDV	SDV	SDV
Size 1	8	8	8	6
Max Primary (CFM)	440	490	540	160
Min Primary (CFM)	88	98	108	32
Heat Min (CFM)	88	98	108	32
Terminal Liner	FF50	FF50	FF50	FF50
Sequence	2000	2000	2000	2000
Aux/Fan/Mix	0	0	0	0
Accessories 2	CLH	CRH	CLH	CLH
Accessories 6	DSW	DSW	DSW	DSW
Comments	8 Size 8	8 Size 8	8 Size 8	6 Size 6

Tag	5-17	5-18	6-1	6-2
#	84	85	86	87
Qty	1	1	1	1
Model	SDV	SDV	SDV	SDV
Size 1	8	8	12	6
Max Primary (CFM)	260	260	1440	100
Min Primary (CFM)	52	52	288	20
Heat Min (CFM)	52	52	288	20
Terminal Liner	FF50	FF50	FF50	FF50
Sequence	2000	2000	2000	2000
Aux/Fan/Mix	0	0	0	0
Accessories 2	CLH	CRH	CLH	CLH
Accessories 6	DSW	DSW	DSW	DSW
Comments	8 Size 8	8 Size 8	12 Size 12	6 Size 6

Tag	6-3	6-4	6-5	6-6
#	88	89	90	91
Qty	1	1	1	1
Model	SDV	SDV	SDV	SDV
Size 1	12	8	12	12
Max Primary (CFM)	1120	360	1200	1200
Min Primary (CFM)	224	72	240	240
Heat Min (CFM)	224	72	240	200
Terminal Liner	FF50	FF50	FF50	FF50
Sequence	2000	2000	2000	2000
Aux/Fan/Mix	0	0	0	0
Accessories 2	CLH	CRH	CLH	CLH
Accessories 6	DSW	DSW	DSW	DSW
Comments	12 Size 12	8 Size 8	12 Size 12	12 Size 12

Tag	6-7	6-8	6-9	6-10
#	92	93	94	95
Qty	1	1	1	1
Model	SDV	SDV	SDV	SDV
Size 1	12	10	6	6
Max Primary (CFM)	1200	760	150	200
Min Primary (CFM)	240	152	30	40
Heat Min (CFM)	240	152	30	40
Terminal Liner	FF50	FF50	FF50	FF50
Sequence	2000	2000	2000	2000
Aux/Fan/Mix	0	0	0	0
Accessories 2	CRH	CLH	CLH	CRH
Accessories 6	DSW	DSW	DSW	DSW
Comments	12 Size 12	10 Size 10	6 Size 6	6 Size 6

Tag	6-11	6-12	6-13	6-14 ADD
#	96	97	98	99
Qty	1	1	1	1
Model	SDV	SDV	SDV	SDV
Size 1	12	6	6	10
Max Primary (CFM)	1100	180	130	700
Min Primary (CFM)	220	36	26	140
Heat Min (CFM)	220	36	26	26
Terminal Liner	FF50	FF50	FF50	FF50
Sequence	2000	2000	2000	2000
Aux/Fan/Mix	0	0	0	0
Accessories 2	CLH	CLH	CLH	CLH
Accessories 6	DSW	DSW	DSW	DSW
Comments	12 Size 12	6 Size 6	6 Size 6	10 Size 10



Performance Notes

Date Printed: 12/27/2022

1. Dashes (--) indicate NC values less than 20.
2. Sound power levels are given in decibels (dB).
3. Dashes (--) indicate sound power levels below 36-29-26-22-19-17 for each octave band; values below these sound power levels are considered below significance per AHRI 880.
4. Minimum operating pressure is the minimum static pressure required to operate the terminal item assembly at maximum primary flow with a wide open damper.
5. Airflow is given in cubic feet per minute (cfm).
6. Air pressure drop is given in inches water gauge (in. w.g.), and water pressure drop is given in feet of water gauge (ft. w.g.).

SDV Single Duct

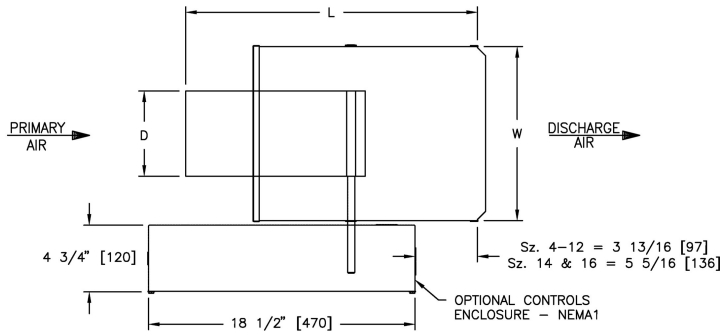

Unit Size	Casing Size	Inlet		Casing		Length
		D	E	W	H	L
8	8	7 7/8	N/A	12	10	20 1/8

Controls Type

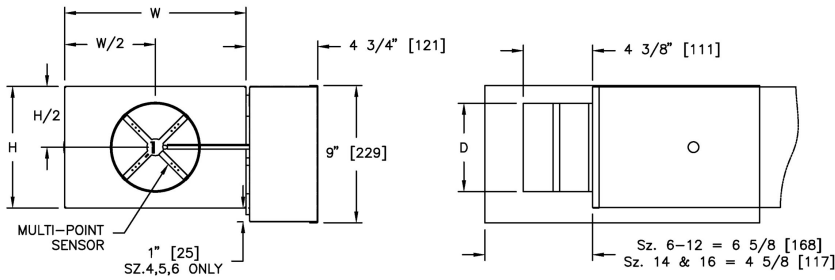

- Multi-point, center averaging airflow sensor.
- For left hand controls, unit orientation is mirrored from main image.
- Controls are supplied by controls contractor and field installed.
- DSW - Disconnect switch included.
- 115-24V control transformer included.
- PS - Nema 1 controls enclosure included.
- Pressure independent

Notes

- 22 Gauge zinc coated steel housing. Mechanically sealed, leak resistant construction.
- Rectangular discharge opening with slip and drive cleat duct connection.
- Assembly ETL certified to UL873.
- Damper blade constructed of two layers of galvanized steel with a sandwiched peripheral gasket.
- 1/2" (13) diameter zinc coated damper shaft with position indicator.
- Units not to be used for temporary heat or ventilation during construction.

Insulation: FF50

- Internal Insulation - Fiber Free Foam 1/2" (13mm) thick, 1.5 lb/cu.ft density, meets requirements of NFPA90A and UL 181
- R-Value=2

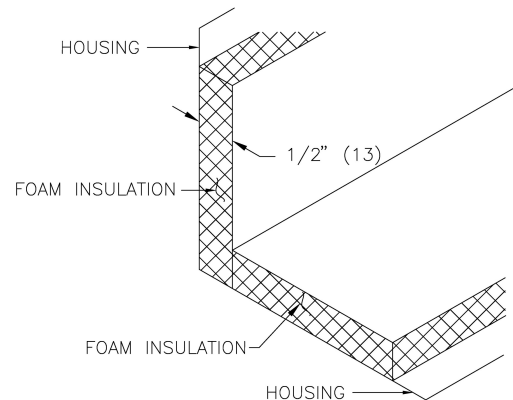

PROJECT: AMN Healthcare Project

ENGINEER:

DESCRIPTION: Single Duct Variable Volume

SDV-1-1/11/8/FLD///CFM/CLH/FF50//22GA/PS/////0.00/////////0.0/////////62/310/62/310/0/////115-24V/DSW/////////2000

SUBMITTAL NO: 269757-B

CUSTOMER: TD Industries

SUBMITTAL DATE: 12/27/2022

SDV Single Duct

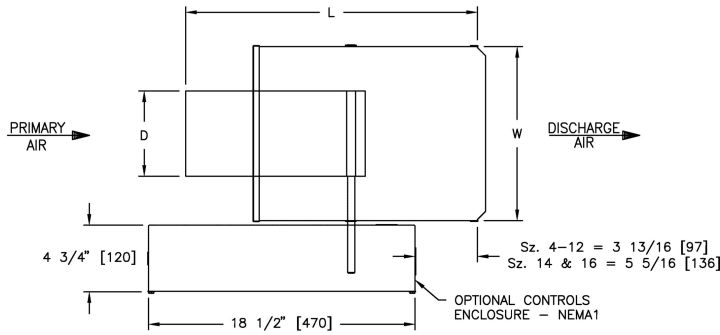

Unit Size	Casing Size	Inlet		Casing		Length
		D	E	W	H	L
12	12	11 7/8	N/A	16	15	20 1/8

Controls Type

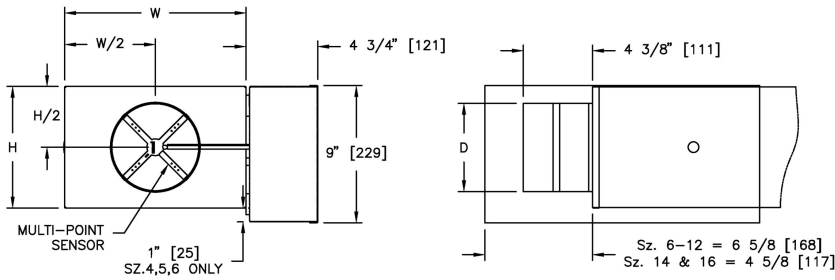

- Multi-point, center averaging airflow sensor.
- For left hand controls, unit orientation is mirrored from main image.
- Controls are supplied by controls contractor and field installed.
- DSW - Disconnect switch included.
- 115-24V control transformer included.
- PS - Nema 1 controls enclosure included.
- Pressure independent

Notes

- 22 Gauge zinc coated steel housing. Mechanically sealed, leak resistant construction.
- Rectangular discharge opening with slip and drive cleat duct connection.
- Assembly ETL certified to UL873.
- Damper blade constructed of two layers of galvanized steel with a sandwiched peripheral gasket.
- 1/2" (13) diameter zinc coated damper shaft with position indicator.
- Units not to be used for temporary heat or ventilation during construction.

Insulation: FF50

- Internal Insulation - Fiber Free Foam 1/2" (13mm) thick, 1.5 lb/cu.ft density, meets requirements of NFPA90A and UL 181
- R-Value=2

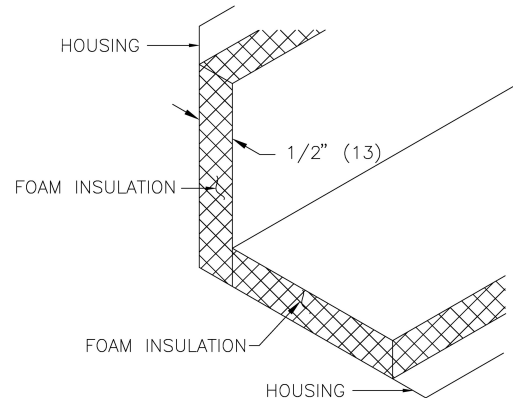

PROJECT: AMN Healthcare Project

ENGINEER:

DESCRIPTION: Single Duct Variable Volume

SDV-1-1//112/FLD//CFM/CLH/FF50//22GA/PS/////0.00//////////0.0//////////228/1140/228/1140/0/////115-24V/DSW//////////2000

SUBMITTAL NO: 269757-B

CUSTOMER: TD Industries

SUBMITTAL DATE: 12/27/2022

SDV Single Duct

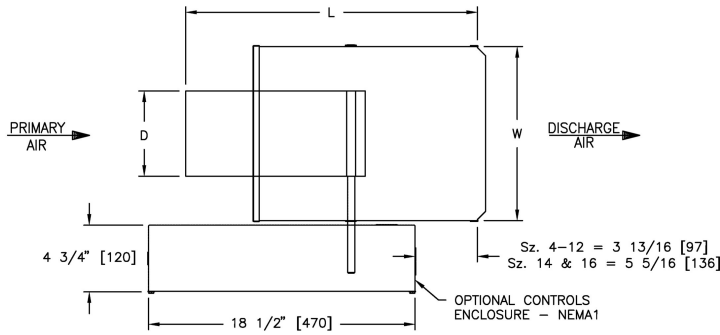

Unit Size	Casing Size	Inlet		Casing		Length
		D	E	W	H	L
10	10	9 7/8	N/A	14	12 1/2	20 1/8

Controls Type

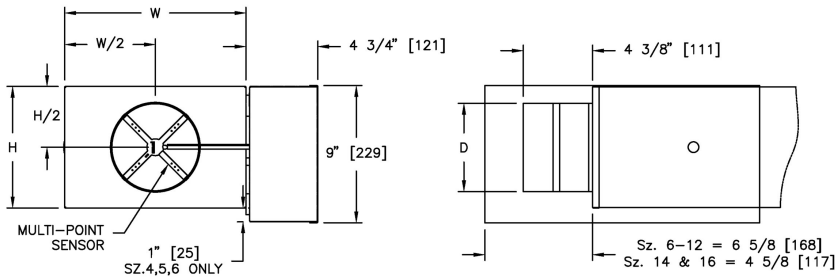

- Multi-point, center averaging airflow sensor.
- Controls enclosure will be supplied as illustrated on right hand side.
- Controls are supplied by controls contractor and field installed.
- DSW - Disconnect switch included.
- 115-24V control transformer included.
- PS - Nema 1 controls enclosure included.
- Pressure independent

Notes

- 22 Gauge zinc coated steel housing. Mechanically sealed, leak resistant construction.
- Rectangular discharge opening with slip and drive cleat duct connection.
- Assembly ETL certified to UL873.
- Damper blade constructed of two layers of galvanized steel with a sandwiched peripheral gasket.
- 1/2" (13) diameter zinc coated damper shaft with position indicator.
- Units not to be used for temporary heat or ventilation during construction.

Insulation: FF50

- Internal Insulation - Fiber Free Foam 1/2" (13mm) thick, 1.5 lb/cu.ft density, meets requirements of NFPA90A and UL 181
- R-Value=2

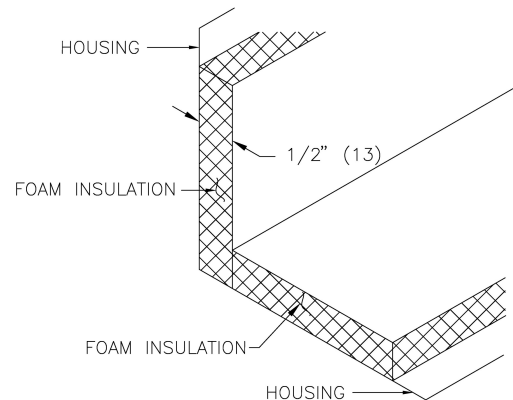

PROJECT: AMN Healthcare Project

ENGINEER:

DESCRIPTION: Single Duct Variable Volume

SDV-1-1//10/FLD//CFM/CRH/FF50//22GA/PS//0.00//0.0//144/720/144/720/0//115-24V/DSW//2000

SUBMITTAL NO: 269757-B

CUSTOMER: TD Industries

SUBMITTAL DATE: 12/27/2022

SDV Single Duct

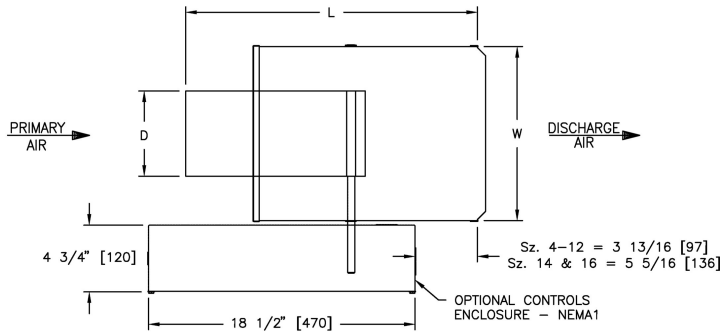

Unit Size	Casing Size	Inlet		Casing		Length
		D	E	W	H	L
6	6	5 7/8	N/A	12	8	20 1/8

Controls Type

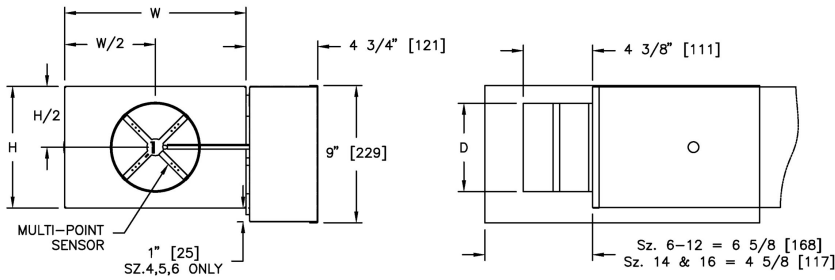

- Multi-point, center averaging airflow sensor.
- Controls enclosure will be supplied as illustrated on right hand side.
- Controls are supplied by controls contractor and field installed.
- DSW - Disconnect switch included.
- 115-24V control transformer included.
- PS - Nema 1 controls enclosure included.
- Pressure independent

Notes

- 22 Gauge zinc coated steel housing. Mechanically sealed, leak resistant construction.
- Rectangular discharge opening with slip and drive cleat duct connection.
- Assembly ETL certified to UL873.
- Damper blade constructed of two layers of galvanized steel with a sandwiched peripheral gasket.
- 1/2" (13) diameter zinc coated damper shaft with position indicator.
- Units not to be used for temporary heat or ventilation during construction.

Insulation: FF50

- Internal Insulation - Fiber Free Foam 1/2" (13mm) thick, 1.5 lb/cu.ft density, meets requirements of NFPA90A and UL 181
- R-Value=2

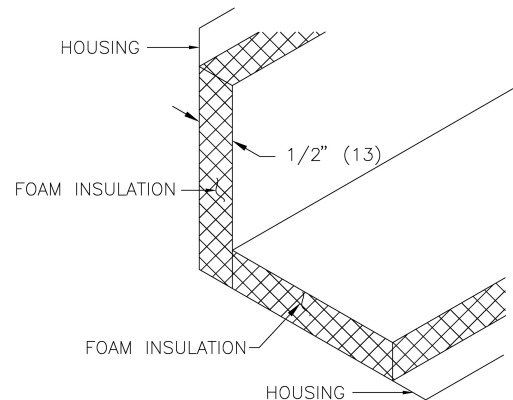

PROJECT: AMN Healthcare Project

ENGINEER:

DESCRIPTION: Single Duct Variable Volume

SDV-1-1/11/6/FLD///CFM/CRH/FF50//22GA/PS/////0.00////////0.0////////46/230/46/230/0/////115-24V/DSW////////2000

SUBMITTAL NO: 269757-B

CUSTOMER: TD Industries

SUBMITTAL DATE: 12/27/2022

SDV Single Duct

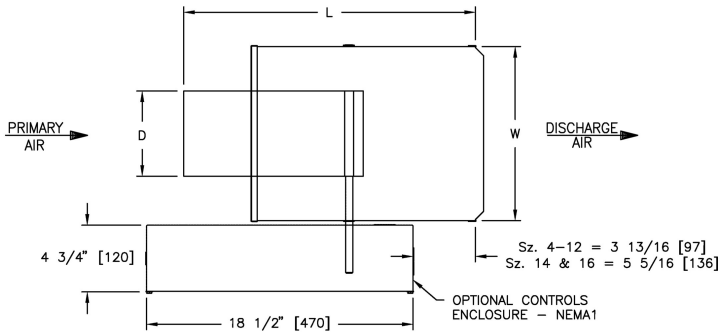

Unit Size	Casing Size	Inlet		Casing		Length
		D	E	W	H	L
8	8	7 7/8	N/A	12	10	20 1/8

Controls Type

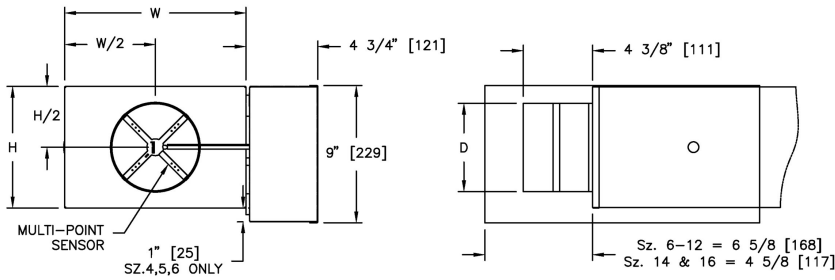

- Multi-point, center averaging airflow sensor.
- For left hand controls, unit orientation is mirrored from main image.
- Controls are supplied by controls contractor and field installed.
- DSW - Disconnect switch included.
- 115-24V control transformer included.
- PS - Nema 1 controls enclosure included.
- Pressure independent

Notes

- 22 Gauge zinc coated steel housing. Mechanically sealed, leak resistant construction.
- Rectangular discharge opening with slip and drive cleat duct connection.
- Assembly ETL certified to UL873.
- Damper blade constructed of two layers of galvanized steel with a sandwiched peripheral gasket.
- 1/2" (13) diameter zinc coated damper shaft with position indicator.
- Units not to be used for temporary heat or ventilation during construction.

Insulation: FF50

- Internal Insulation - Fiber Free Foam 1/2" (13mm) thick, 1.5 lb/cu.ft density, meets requirements of NFPA90A and UL 181
- R-Value=2

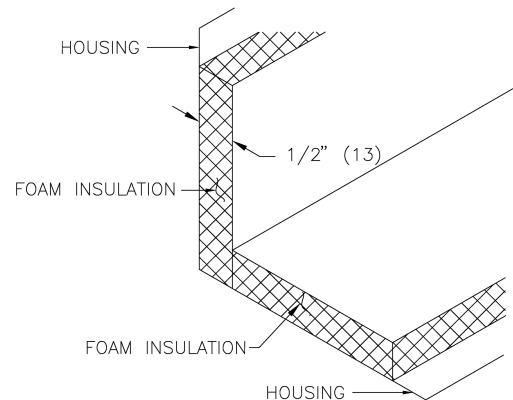

PROJECT: AMN Healthcare Project

ENGINEER:

DESCRIPTION: Single Duct Variable Volume

SDV-1-1//11/8/FLD///CFM/CLH/FF50//22GA/PS/////0.00////////0.0////////104/520/104/520/0////////115-24V/DSW////////2000

SUBMITTAL NO: 269757-B

CUSTOMER: TD Industries

SUBMITTAL DATE: 12/27/2022

SDV Single Duct

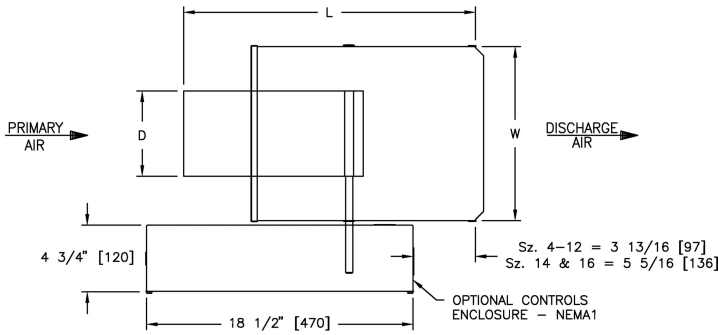

Unit Size	Casing Size	Inlet		Casing		Length
		D	E	W	H	L
6	6	5 7/8	N/A	12	8	20 1/8

Controls Type

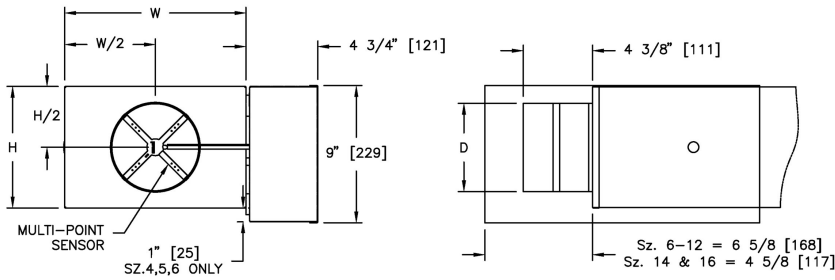

- Multi-point, center averaging airflow sensor.
- Controls enclosure will be supplied as illustrated on right hand side.
- Controls are supplied by controls contractor and field installed.
- DSW - Disconnect switch included.
- 115-24V control transformer included.
- PS - Nema 1 controls enclosure included.
- Pressure independent

Notes

- 22 Gauge zinc coated steel housing. Mechanically sealed, leak resistant construction.
- Rectangular discharge opening with slip and drive cleat duct connection.
- Assembly ETL certified to UL873.
- Damper blade constructed of two layers of galvanized steel with a sandwiched peripheral gasket.
- 1/2" (13) diameter zinc coated damper shaft with position indicator.
- Units not to be used for temporary heat or ventilation during construction.

Insulation: FF50

- Internal Insulation - Fiber Free Foam 1/2" (13mm) thick, 1.5 lb/cu.ft density, meets requirements of NFPA90A and UL 181
- R-Value=2

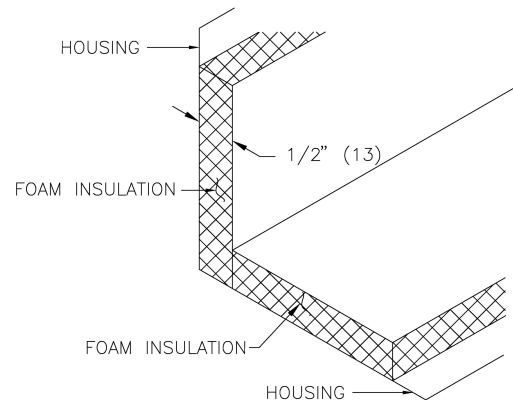

PROJECT: AMN Healthcare Project

ENGINEER:

DESCRIPTION: Single Duct Variable Volume

SDV-1-1/11/6/FLD///CFM/CRH/FF50//22GA/PS/////0.00////////0.0////////48/240/48/240/0/////115-24V/DSW////////2000

SUBMITTAL NO: 269757-B

CUSTOMER: TD Industries

SUBMITTAL DATE: 12/27/2022

SDV Single Duct

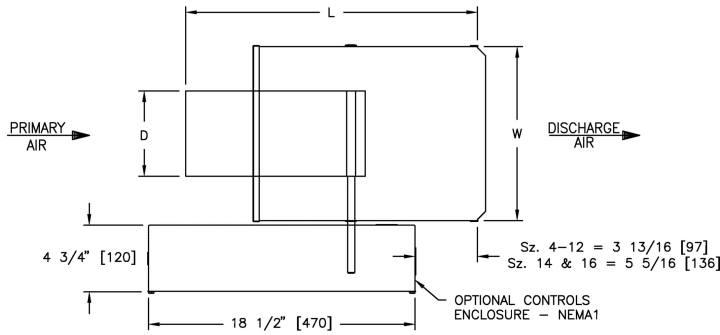

Unit Size	Casing Size	Inlet		Casing		Length
		D	E	W	H	L
6	6	5 7/8	N/A	12	8	20 1/8

Controls Type

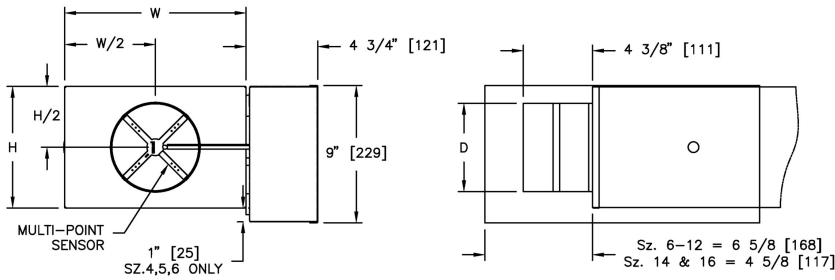

- Multi-point, center averaging airflow sensor.
- For left hand controls, unit orientation is mirrored from main image.
- Controls are supplied by controls contractor and field installed.
- DSW - Disconnect switch included.
- 115-24V control transformer included.
- PS - Nema 1 controls enclosure included.
- Pressure independent

Notes

- 22 Gauge zinc coated steel housing. Mechanically sealed, leak resistant construction.
- Rectangular discharge opening with slip and drive cleat duct connection.
- Assembly ETL certified to UL873.
- Damper blade constructed of two layers of galvanized steel with a sandwiched peripheral gasket.
- 1/2" (13) diameter zinc coated damper shaft with position indicator.
- Units not to be used for temporary heat or ventilation during construction.

Insulation: FF50

- Internal Insulation - Fiber Free Foam 1/2" (13mm) thick, 1.5 lb/cu.ft density, meets requirements of NFPA90A and UL 181
- R-Value=2

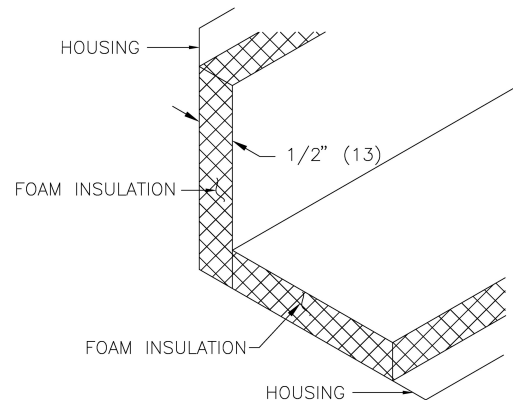

PROJECT: AMN Healthcare Project

ENGINEER:

DESCRIPTION: Single Duct Variable Volume

SDV-1-1//116/FLD///CFM/CLH/FF50//22GA/PS/////0.00////////0.0////////48/240/48/240/0/////115-24V/DSW////////2000

SUBMITTAL NO: 269757-B

CUSTOMER: TD Industries

SUBMITTAL DATE: 12/27/2022

SDV Single Duct

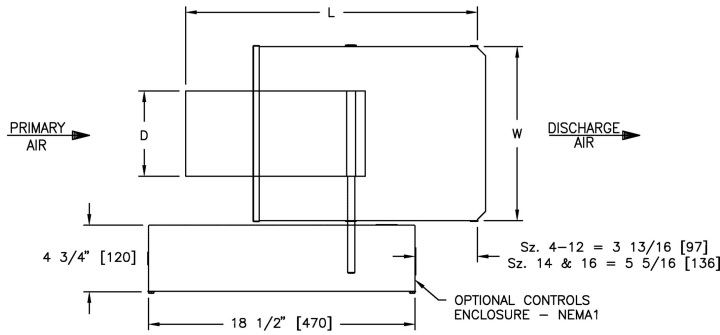

Unit Size	Casing Size	Inlet		Casing		Length
		D	E	W	H	L
10	10	9 7/8	N/A	14	12 1/2	20 1/8

Controls Type

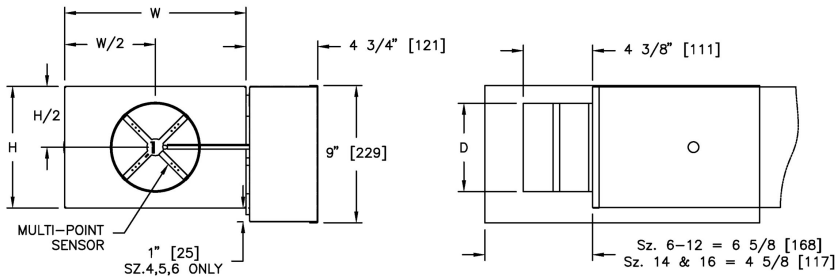

- Multi-point, center averaging airflow sensor.
- For left hand controls, unit orientation is mirrored from main image.
- Controls are supplied by controls contractor and field installed.
- DSW - Disconnect switch included.
- 115-24V control transformer included.
- PS - Nema 1 controls enclosure included.
- Pressure independent

Notes

- 22 Gauge zinc coated steel housing. Mechanically sealed, leak resistant construction.
- Rectangular discharge opening with slip and drive cleat duct connection.
- Assembly ETL certified to UL873.
- Damper blade constructed of two layers of galvanized steel with a sandwiched peripheral gasket.
- 1/2" (13) diameter zinc coated damper shaft with position indicator.
- Units not to be used for temporary heat or ventilation during construction.

Insulation: FF50

- Internal Insulation - Fiber Free Foam 1/2" (13mm) thick, 1.5 lb/cu.ft density, meets requirements of NFPA90A and UL 181
- R-Value=2

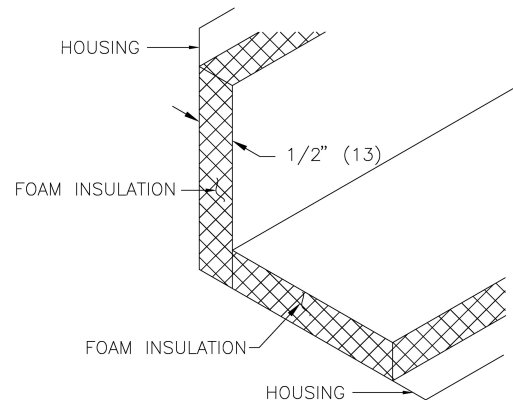

PROJECT: AMN Healthcare Project

ENGINEER:

DESCRIPTION: Single Duct Variable Volume

SDV-1-1//10/FLD//CFM/CLH/FF50//22GA/PS//0.00//0.0//162/810/162/810/0//115-24V/DSW//2000

SUBMITTAL NO: 269757-B

CUSTOMER: TD Industries

SUBMITTAL DATE: 12/27/2022

SDV Single Duct

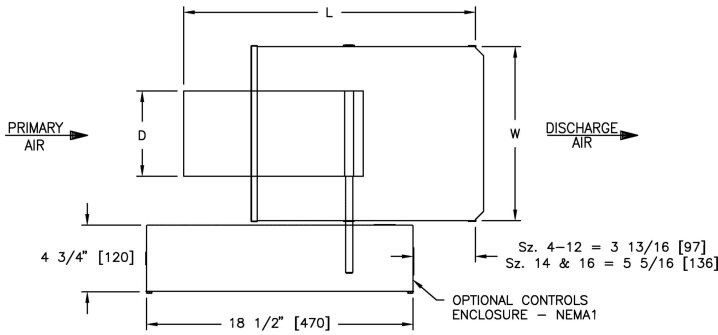

Unit Size	Casing Size	Inlet		Casing		Length
		D	E	W	H	L
6	6	5 7/8	N/A	12	8	20 1/8

Controls Type

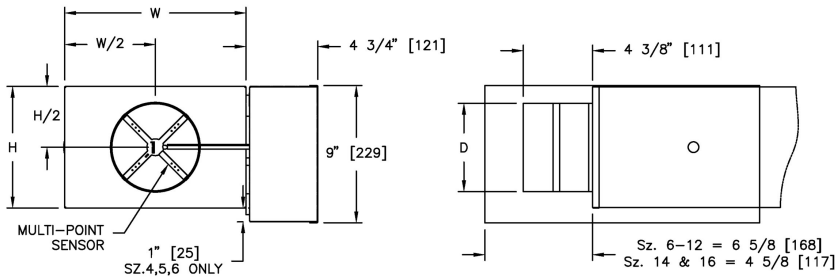

- Multi-point, center averaging airflow sensor.
- Controls enclosure will be supplied as illustrated on right hand side.
- Controls are supplied by controls contractor and field installed.
- DSW - Disconnect switch included.
- 115-24V control transformer included.
- PS - Nema 1 controls enclosure included.
- Pressure independent

Notes

- 22 Gauge zinc coated steel housing. Mechanically sealed, leak resistant construction.
- Rectangular discharge opening with slip and drive cleat duct connection.
- Assembly ETL certified to UL873.
- Damper blade constructed of two layers of galvanized steel with a sandwiched peripheral gasket.
- 1/2" (13) diameter zinc coated damper shaft with position indicator.
- Units not to be used for temporary heat or ventilation during construction.

Insulation: FF50

- Internal Insulation - Fiber Free Foam 1/2" (13mm) thick, 1.5 lb/cu.ft density, meets requirements of NFPA90A and UL 181
- R-Value=2

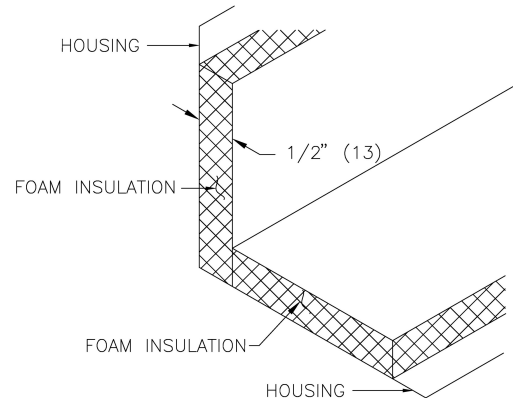

PROJECT: AMN Healthcare Project

ENGINEER:

DESCRIPTION: Single Duct Variable Volume

SDV-1-1/11/6/FLD///CFM/CRH/FF50//22GA/PS/////0.00//////////0.0//////////45/225/45/225/0/////115-24V/DSW//////////2000

SUBMITTAL NO: 269757-B

CUSTOMER: TD Industries

SUBMITTAL DATE: 12/27/2022

SDV Single Duct

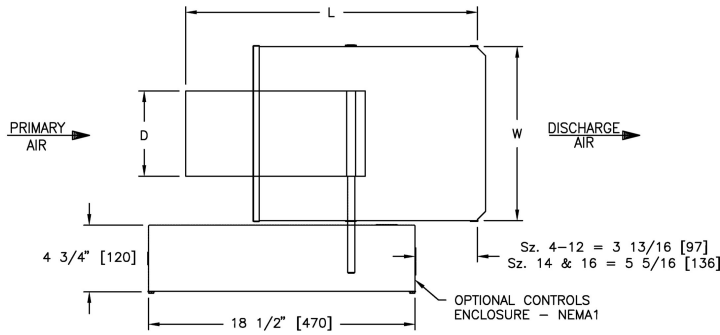

Unit Size	Casing Size	Inlet		Casing		Length
		D	E	W	H	L
8	8	7 7/8	N/A	12	10	20 1/8

Controls Type

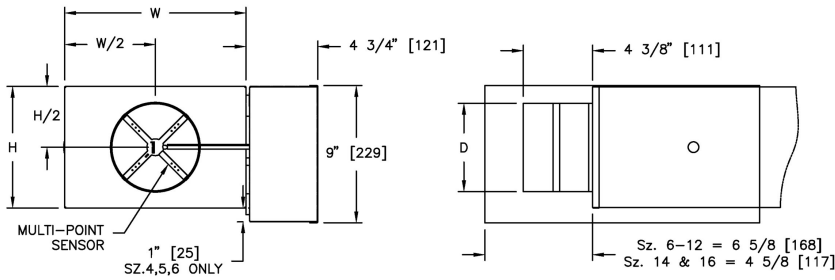

- Multi-point, center averaging airflow sensor.
- For left hand controls, unit orientation is mirrored from main image.
- Controls are supplied by controls contractor and field installed.
- DSW - Disconnect switch included.
- 115-24V control transformer included.
- PS - Nema 1 controls enclosure included.
- Pressure independent

Notes

- 22 Gauge zinc coated steel housing. Mechanically sealed, leak resistant construction.
- Rectangular discharge opening with slip and drive cleat duct connection.
- Assembly ETL certified to UL873.
- Damper blade constructed of two layers of galvanized steel with a sandwiched peripheral gasket.
- 1/2" (13) diameter zinc coated damper shaft with position indicator.
- Units not to be used for temporary heat or ventilation during construction.

Insulation: FF50

- Internal Insulation - Fiber Free Foam 1/2" (13mm) thick, 1.5 lb/cu.ft density, meets requirements of NFPA90A and UL 181
- R-Value=2

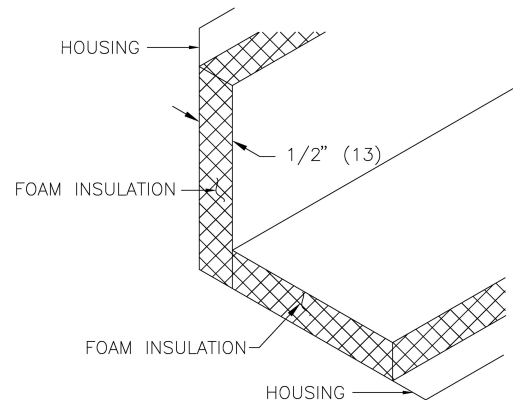

PROJECT: AMN Healthcare Project

ENGINEER:

DESCRIPTION: Single Duct Variable Volume

SDV-1-1//11/8/FLD///CFM/CLH/FF50//22GA/PS/////0.00////////0.0////////52/260/52/260/0/////115-24V/DSW////////2000

SUBMITTAL NO: 269757-B

CUSTOMER: TD Industries

SUBMITTAL DATE: 12/27/2022

SDV Single Duct

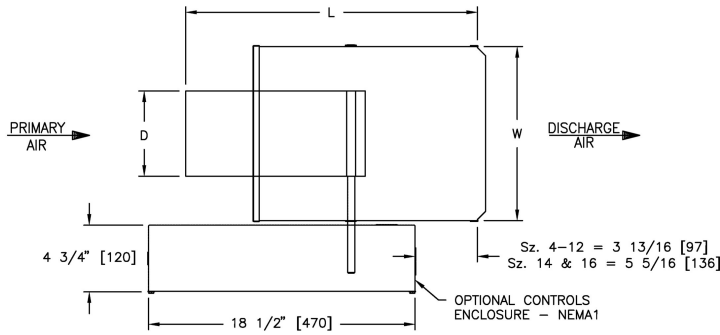

Unit Size	Casing Size	Inlet		Casing		Length
		D	E	W	H	L
8	8	7 7/8	N/A	12	10	20 1/8

Controls Type

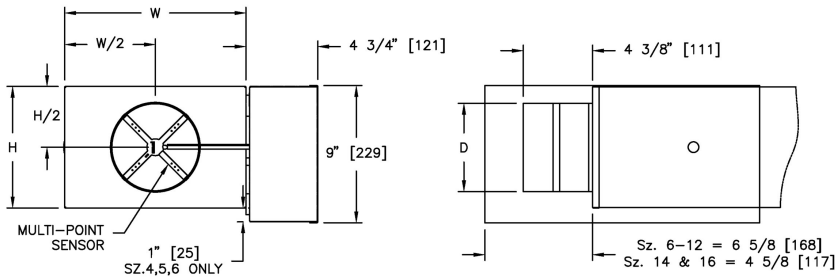

- Multi-point, center averaging airflow sensor.
- Controls enclosure will be supplied as illustrated on right hand side.
- Controls are supplied by controls contractor and field installed.
- DSW - Disconnect switch included.
- 115-24V control transformer included.
- PS - Nema 1 controls enclosure included.
- Pressure independent

Notes

- 22 Gauge zinc coated steel housing. Mechanically sealed, leak resistant construction.
- Rectangular discharge opening with slip and drive cleat duct connection.
- Assembly ETL certified to UL873.
- Damper blade constructed of two layers of galvanized steel with a sandwiched peripheral gasket.
- 1/2" (13) diameter zinc coated damper shaft with position indicator.
- Units not to be used for temporary heat or ventilation during construction.

Insulation: FF50

- Internal Insulation - Fiber Free Foam 1/2" (13mm) thick, 1.5 lb/cu.ft density, meets requirements of NFPA90A and UL 181
- R-Value=2

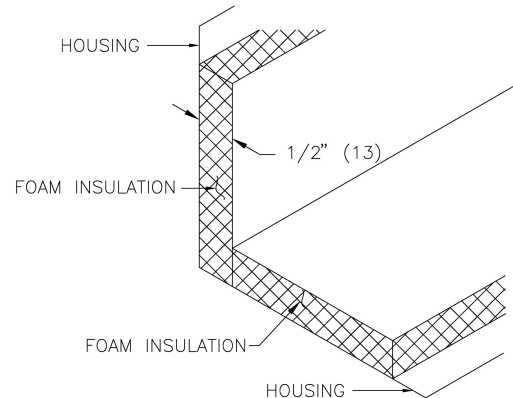

PROJECT: AMN Healthcare Project

ENGINEER:

DESCRIPTION: Single Duct Variable Volume

SDV-1-1/11/8/FLD///CFM/CRH/FF50//22GA/PS/////0.00//////////0.0//////////87/435/40/200/0/////115-24V/DSW//////////2000

SUBMITTAL NO: 269757-B

CUSTOMER: TD Industries

SUBMITTAL DATE: 12/27/2022

SDV Single Duct

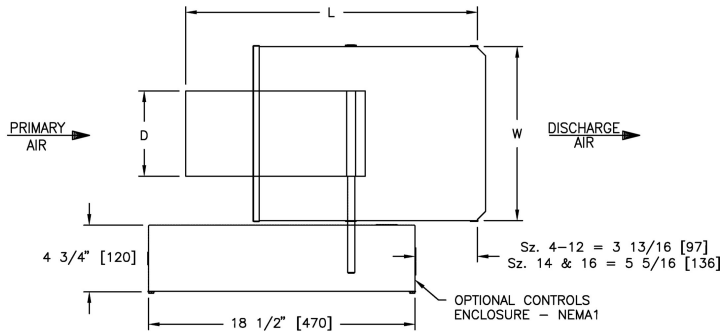

Unit Size	Casing Size	Inlet		Casing		Length
		D	E	W	H	L
8	8	7 7/8	N/A	12	10	20 1/8

Controls Type

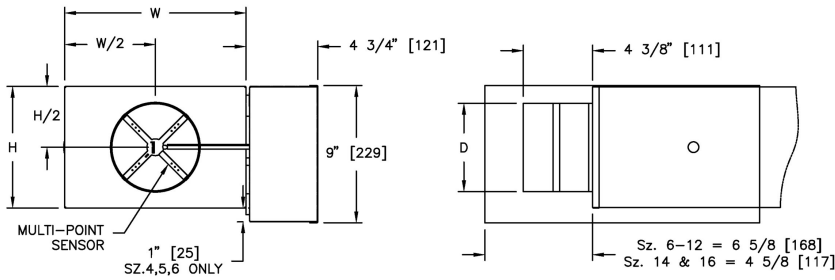

- Multi-point, center averaging airflow sensor.
- For left hand controls, unit orientation is mirrored from main image.
- Controls are supplied by controls contractor and field installed.
- DSW - Disconnect switch included.
- 115-24V control transformer included.
- PS - Nema 1 controls enclosure included.
- Pressure independent

Notes

- 22 Gauge zinc coated steel housing. Mechanically sealed, leak resistant construction.
- Rectangular discharge opening with slip and drive cleat duct connection.
- Assembly ETL certified to UL873.
- Damper blade constructed of two layers of galvanized steel with a sandwiched peripheral gasket.
- 1/2" (13) diameter zinc coated damper shaft with position indicator.
- Units not to be used for temporary heat or ventilation during construction.

Insulation: FF50

- Internal Insulation - Fiber Free Foam 1/2" (13mm) thick, 1.5 lb/cu.ft density, meets requirements of NFPA90A and UL 181
- R-Value=2

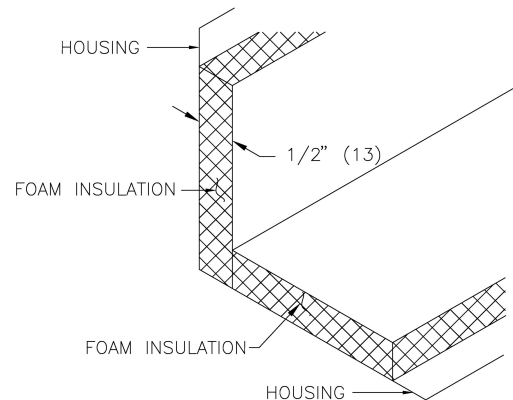

PROJECT: AMN Healthcare Project

ENGINEER:

DESCRIPTION: Single Duct Variable Volume

SDV-1-1/11/8/FLD///CFM/CLH/FF50//22GA/PS/////0.00/////////0.0/////////88/440/88/440/0/////////115-24V/DSW/////////2000

SUBMITTAL NO: 269757-B

CUSTOMER: TD Industries

SUBMITTAL DATE: 12/27/2022

SDV Single Duct

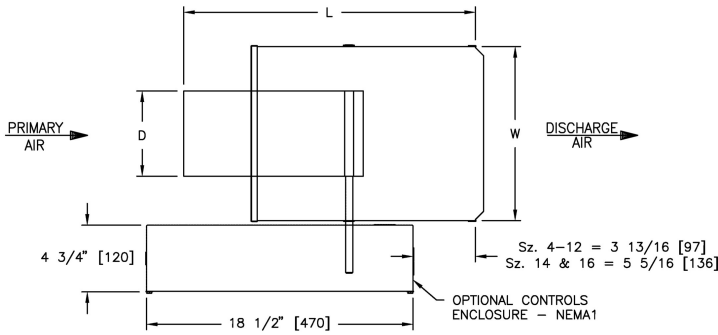

Unit Size	Casing Size	Inlet		Casing		Length
		D	E	W	H	L
8	8	7 7/8	N/A	12	10	20 1/8

Controls Type

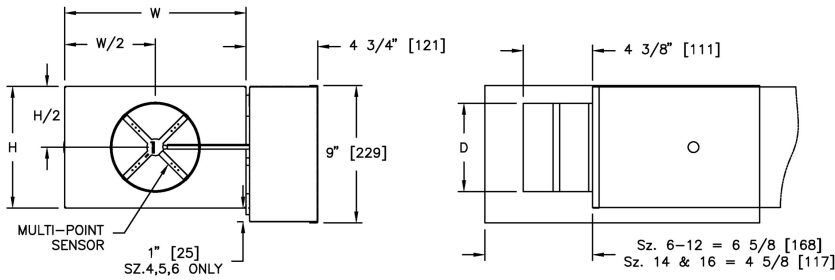

- Multi-point, center averaging airflow sensor.
- For left hand controls, unit orientation is mirrored from main image.
- Controls are supplied by controls contractor and field installed.
- DSW - Disconnect switch included.
- 115-24V control transformer included.
- PS - Nema 1 controls enclosure included.
- Pressure independent

Notes

- 22 Gauge zinc coated steel housing. Mechanically sealed, leak resistant construction.
- Rectangular discharge opening with slip and drive cleat duct connection.
- Assembly ETL certified to UL873.
- Damper blade constructed of two layers of galvanized steel with a sandwiched peripheral gasket.
- 1/2" (13) diameter zinc coated damper shaft with position indicator.
- Units not to be used for temporary heat or ventilation during construction.

Insulation: FF50

- Internal Insulation - Fiber Free Foam 1/2" (13mm) thick, 1.5 lb/cu.ft density, meets requirements of NFPA90A and UL 181
- R-Value=2

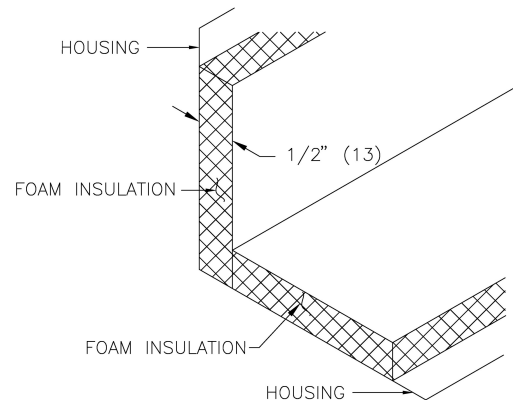

PROJECT: AMN Healthcare Project

ENGINEER:

DESCRIPTION: Single Duct Variable Volume

SDV-1-1/11/8/FLD///CFM/CLH/FF50//22GA/PS/////0.00/////////0.0/////////88/440/88/440/0/////////115-24V/DSW/////////2000

SUBMITTAL NO: 269757-B

CUSTOMER: TD Industries

SUBMITTAL DATE: 12/27/2022

SDV Single Duct

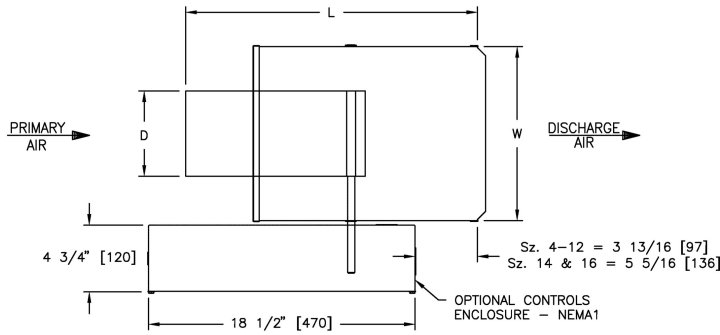

Unit Size	Casing Size	Inlet		Casing		Length
		D	E	W	H	L
8	8	7 7/8	N/A	12	10	20 1/8

Controls Type

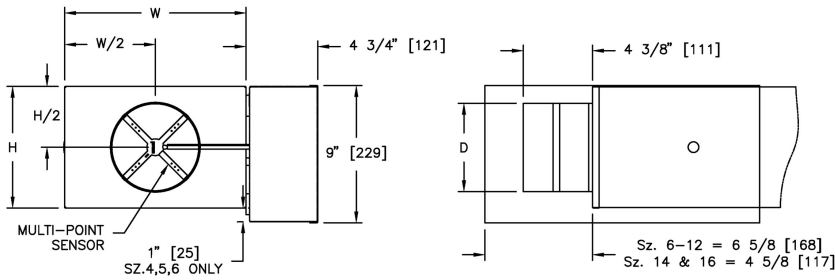

- Multi-point, center averaging airflow sensor.
- Controls enclosure will be supplied as illustrated on right hand side.
- Controls are supplied by controls contractor and field installed.
- DSW - Disconnect switch included.
- 115-24V control transformer included.
- PS - Nema 1 controls enclosure included.
- Pressure independent

Notes

- 22 Gauge zinc coated steel housing. Mechanically sealed, leak resistant construction.
- Rectangular discharge opening with slip and drive cleat duct connection.
- Assembly ETL certified to UL873.
- Damper blade constructed of two layers of galvanized steel with a sandwiched peripheral gasket.
- 1/2" (13) diameter zinc coated damper shaft with position indicator.
- Units not to be used for temporary heat or ventilation during construction.

Insulation: FF50

- Internal Insulation - Fiber Free Foam 1/2" (13mm) thick, 1.5 lb/cu.ft density, meets requirements of NFPA90A and UL 181
- R-Value=2

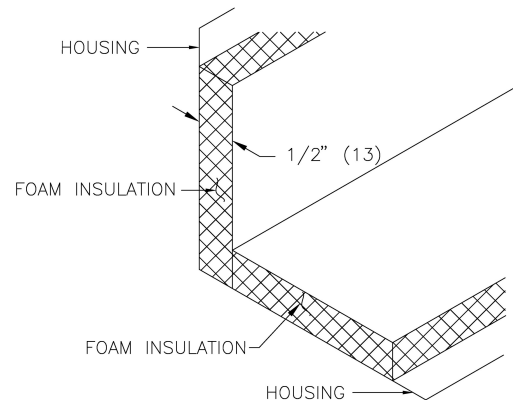

PROJECT: AMN Healthcare Project

ENGINEER:

DESCRIPTION: Single Duct Variable Volume

SDV-1-1/11/8/FLD///CFM/CRH/FF50//22GA/PS/////0.00//////////0.0//////////98/490/98/490/0/////115-24V/DSW//////////2000

SUBMITTAL NO: 269757-B

CUSTOMER: TD Industries

SUBMITTAL DATE: 12/27/2022

SDV Single Duct

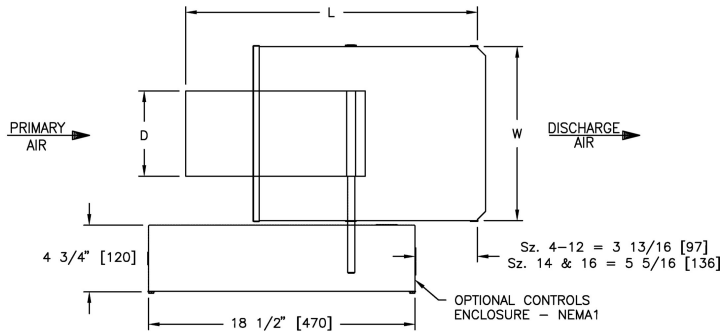

Unit Size	Casing Size	Inlet		Casing		Length
		D	E	W	H	L
8	8	7 7/8	N/A	12	10	20 1/8

Controls Type

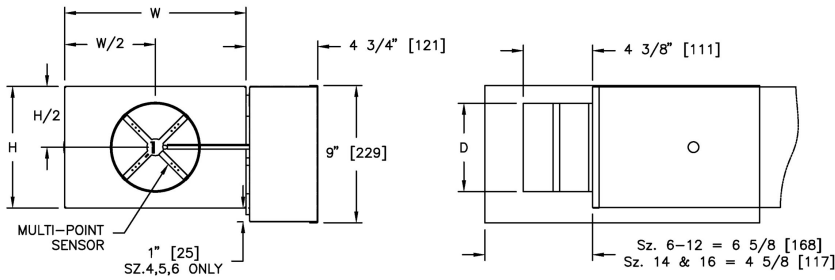

- Multi-point, center averaging airflow sensor.
- For left hand controls, unit orientation is mirrored from main image.
- Controls are supplied by controls contractor and field installed.
- DSW - Disconnect switch included.
- 115-24V control transformer included.
- PS - Nema 1 controls enclosure included.
- Pressure independent

Notes

- 22 Gauge zinc coated steel housing. Mechanically sealed, leak resistant construction.
- Rectangular discharge opening with slip and drive cleat duct connection.
- Assembly ETL certified to UL873.
- Damper blade constructed of two layers of galvanized steel with a sandwiched peripheral gasket.
- 1/2" (13) diameter zinc coated damper shaft with position indicator.
- Units not to be used for temporary heat or ventilation during construction.

Insulation: FF50

- Internal Insulation - Fiber Free Foam 1/2" (13mm) thick, 1.5 lb/cu.ft density, meets requirements of NFPA90A and UL 181
- R-Value=2

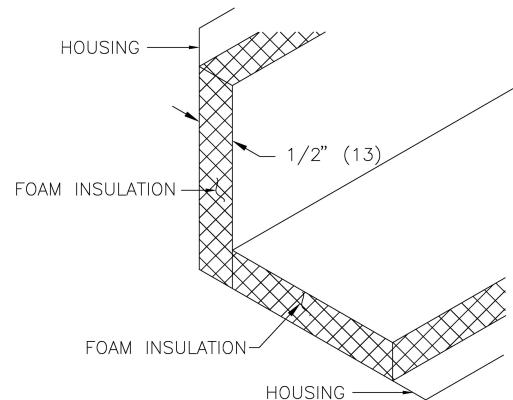

PROJECT: AMN Healthcare Project

ENGINEER:

DESCRIPTION: Single Duct Variable Volume

SDV-1-1/11/8/FLD///CFM/CLH/FF50//22GA/PS/////0.00////////0.0////////108/540/108/540/0/////115-24V/DSW////////2000

SUBMITTAL NO: 269757-B

CUSTOMER: TD Industries

SUBMITTAL DATE: 12/27/2022

SDV Single Duct

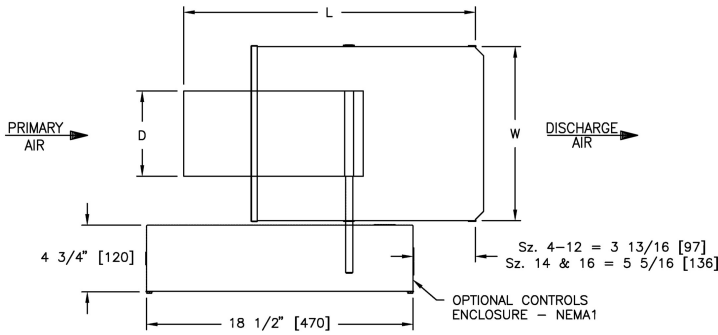

Unit Size	Casing Size	Inlet		Casing		Length
		D	E	W	H	L
6	6	5 7/8	N/A	12	8	20 1/8

Controls Type

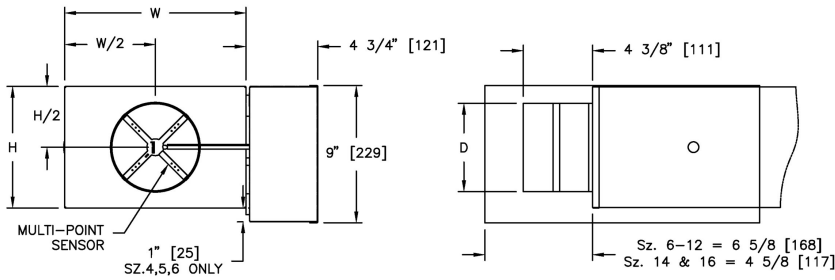

- Multi-point, center averaging airflow sensor.
- For left hand controls, unit orientation is mirrored from main image.
- Controls are supplied by controls contractor and field installed.
- DSW - Disconnect switch included.
- 115-24V control transformer included.
- PS - Nema 1 controls enclosure included.
- Pressure independent

Notes

- 22 Gauge zinc coated steel housing. Mechanically sealed, leak resistant construction.
- Rectangular discharge opening with slip and drive cleat duct connection.
- Assembly ETL certified to UL873.
- Damper blade constructed of two layers of galvanized steel with a sandwiched peripheral gasket.
- 1/2" (13) diameter zinc coated damper shaft with position indicator.
- Units not to be used for temporary heat or ventilation during construction.

Insulation: FF50

- Internal Insulation - Fiber Free Foam 1/2" (13mm) thick, 1.5 lb/cu.ft density, meets requirements of NFPA90A and UL 181
- R-Value=2

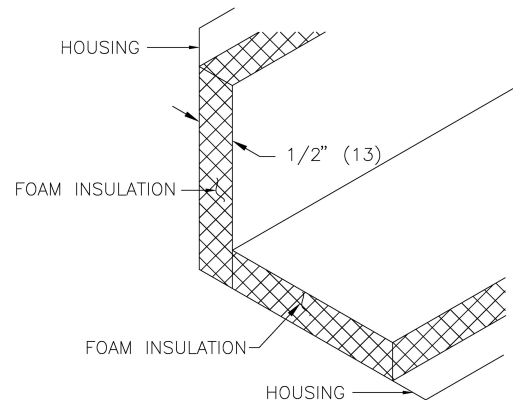

PROJECT: AMN Healthcare Project

ENGINEER:

DESCRIPTION: Single Duct Variable Volume

SDV-1-1//116/FLD///CFM/CLH/FF50//22GA/PS/////0.00////////0.0/////////32/160/32/160/0/////115-24V/DSW/////////2000

SUBMITTAL NO: 269757-B

CUSTOMER: TD Industries

SUBMITTAL DATE: 12/27/2022

SDV Single Duct

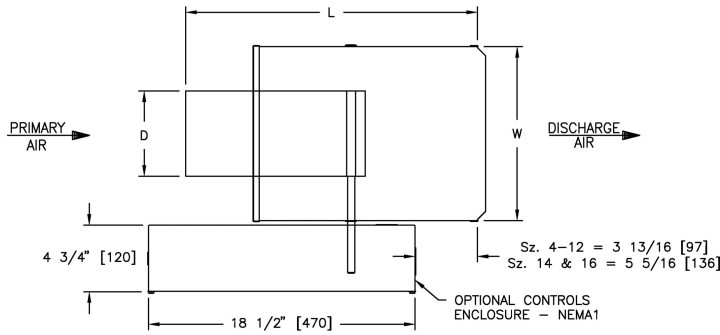

Unit Size	Casing Size	Inlet		Casing		Length
		D	E	W	H	L
8	8	7 7/8	N/A	12	10	20 1/8

Controls Type

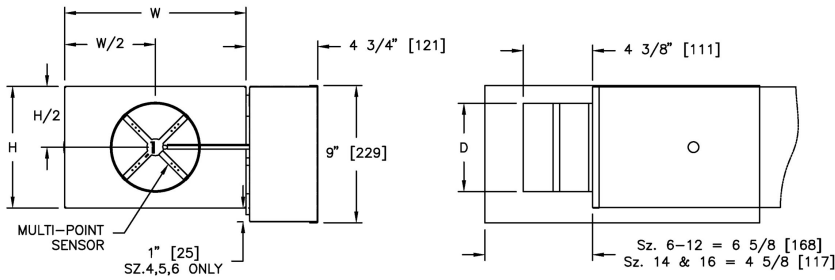

- Multi-point, center averaging airflow sensor.
- For left hand controls, unit orientation is mirrored from main image.
- Controls are supplied by controls contractor and field installed.
- DSW - Disconnect switch included.
- 115-24V control transformer included.
- PS - Nema 1 controls enclosure included.
- Pressure independent

Notes

- 22 Gauge zinc coated steel housing. Mechanically sealed, leak resistant construction.
- Rectangular discharge opening with slip and drive cleat duct connection.
- Assembly ETL certified to UL873.
- Damper blade constructed of two layers of galvanized steel with a sandwiched peripheral gasket.
- 1/2" (13) diameter zinc coated damper shaft with position indicator.
- Units not to be used for temporary heat or ventilation during construction.

Insulation: FF50

- Internal Insulation - Fiber Free Foam 1/2" (13mm) thick, 1.5 lb/cu.ft density, meets requirements of NFPA90A and UL 181
- R-Value=2

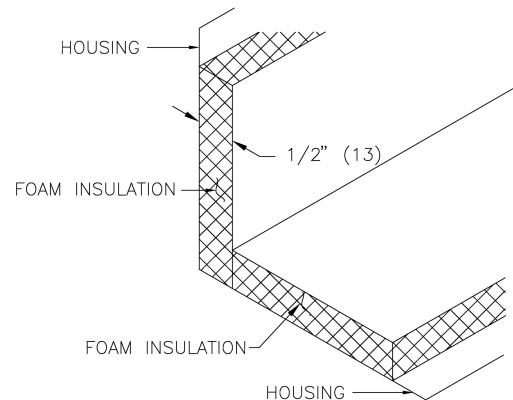

PROJECT: AMN Healthcare Project

ENGINEER:

DESCRIPTION: Single Duct Variable Volume

SDV-1-1//11/8/FLD///CFM/CLH/FF50//22GA/PS/////0.00////////0.0////////52/260/52/260/0/////115-24V/DSW////////2000

SUBMITTAL NO: 269757-B

CUSTOMER: TD Industries

SUBMITTAL DATE: 12/27/2022

SDV Single Duct

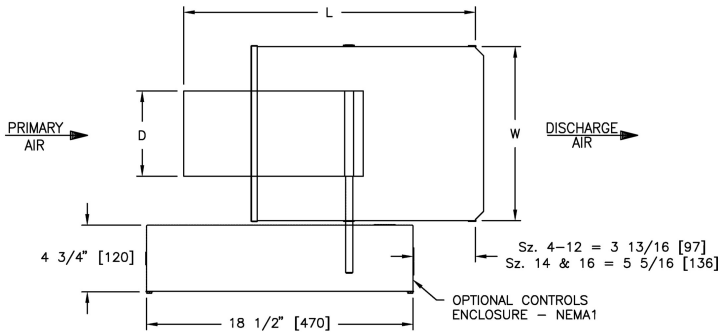

Unit Size	Casing Size	Inlet		Casing		Length
		D	E	W	H	L
8	8	7 7/8	N/A	12	10	20 1/8

Controls Type

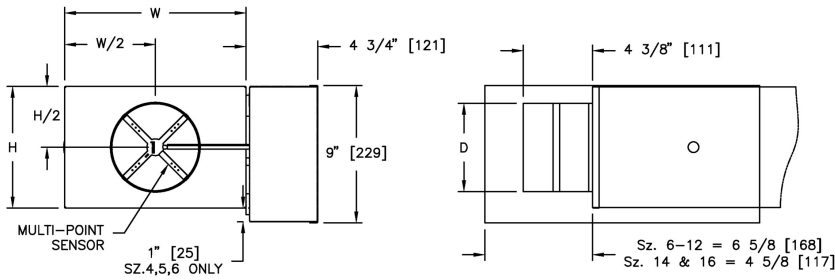

- Multi-point, center averaging airflow sensor.
- Controls enclosure will be supplied as illustrated on right hand side.
- Controls are supplied by controls contractor and field installed.
- DSW - Disconnect switch included.
- 115-24V control transformer included.
- PS - Nema 1 controls enclosure included.
- Pressure independent

Notes

- 22 Gauge zinc coated steel housing. Mechanically sealed, leak resistant construction.
- Rectangular discharge opening with slip and drive cleat duct connection.
- Assembly ETL certified to UL873.
- Damper blade constructed of two layers of galvanized steel with a sandwiched peripheral gasket.
- 1/2" (13) diameter zinc coated damper shaft with position indicator.
- Units not to be used for temporary heat or ventilation during construction.

Insulation: FF50

- Internal Insulation - Fiber Free Foam 1/2" (13mm) thick, 1.5 lb/cu.ft density, meets requirements of NFPA90A and UL 181
- R-Value=2

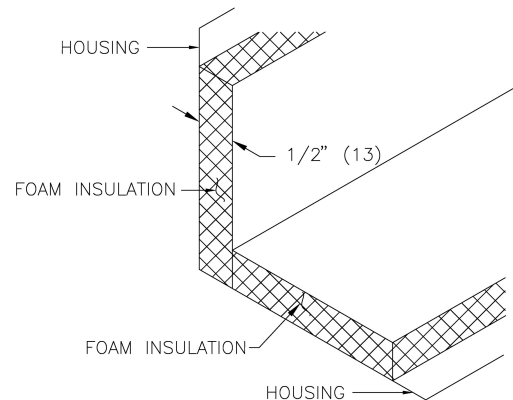

PROJECT: AMN Healthcare Project

ENGINEER:

DESCRIPTION: Single Duct Variable Volume

SDV-1-1/11/8/FLD///CFM/CRH/FF50//22GA/PS/////0.00//////////0.0//////////52/260/52/260/0/////115-24V/DSW//////////2000

SUBMITTAL NO: 269757-B

CUSTOMER: TD Industries

SUBMITTAL DATE: 12/27/2022

SDV Single Duct

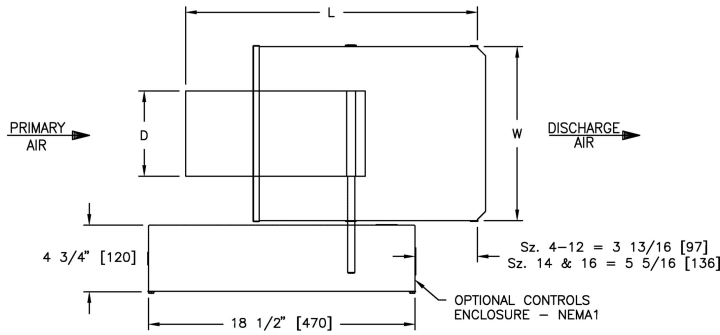

Unit Size	Casing Size	Inlet		Casing		Length
		D	E	W	H	L
12	12	11 7/8	N/A	16	15	20 1/8

Controls Type

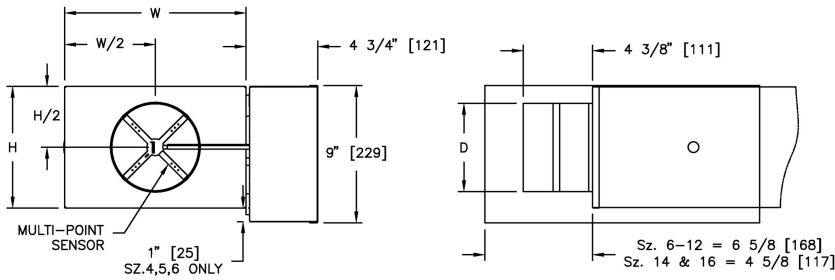

- Multi-point, center averaging airflow sensor.
- For left hand controls, unit orientation is mirrored from main image.
- Controls are supplied by controls contractor and field installed.
- DSW - Disconnect switch included.
- 115-24V control transformer included.
- PS - Nema 1 controls enclosure included.
- Pressure independent

Notes

- 22 Gauge zinc coated steel housing. Mechanically sealed, leak resistant construction.
- Rectangular discharge opening with slip and drive cleat duct connection.
- Assembly ETL certified to UL873.
- Damper blade constructed of two layers of galvanized steel with a sandwiched peripheral gasket.
- 1/2" (13) diameter zinc coated damper shaft with position indicator.
- Units not to be used for temporary heat or ventilation during construction.

Insulation: FF50

- Internal Insulation - Fiber Free Foam 1/2" (13mm) thick, 1.5 lb/cu.ft density, meets requirements of NFPA90A and UL 181
- R-Value=2

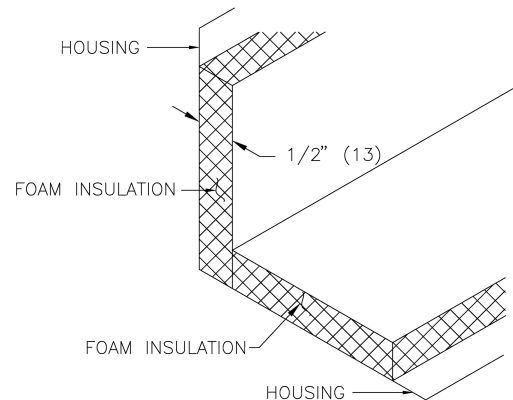

PROJECT: AMN Healthcare Project

ENGINEER:

DESCRIPTION: Single Duct Variable Volume

SDV-1-1//112/FLD//CFM/CLH/FF50//22GA/PS/////0.00//////////0.0//////////288/1440/288/1440/0/////115-24V/DSW//////////2000

SUBMITTAL NO: 269757-B

CUSTOMER: TD Industries

SUBMITTAL DATE: 12/27/2022

SDV Single Duct

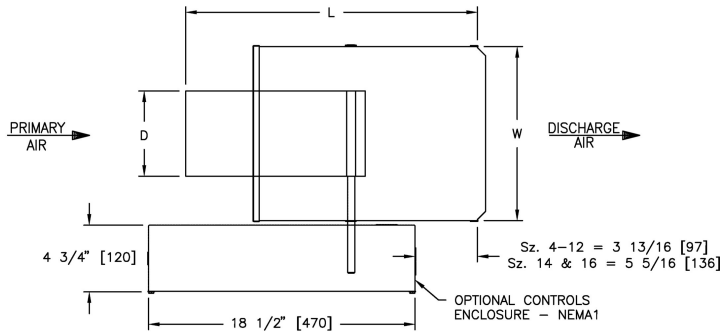

Unit Size	Casing Size	Inlet		Casing		Length
		D	E	W	H	L
6	6	5 7/8	N/A	12	8	20 1/8

Controls Type

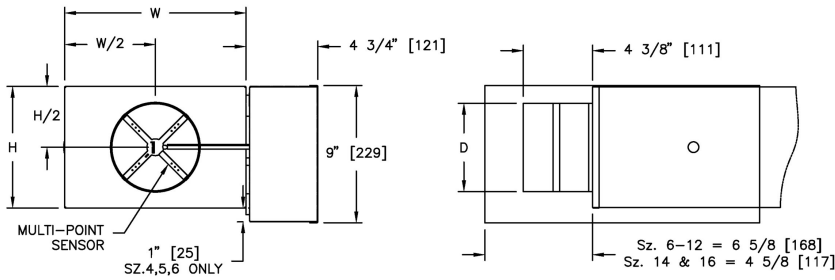

- Multi-point, center averaging airflow sensor.
- For left hand controls, unit orientation is mirrored from main image.
- Controls are supplied by controls contractor and field installed.
- DSW - Disconnect switch included.
- 115-24V control transformer included.
- PS - Nema 1 controls enclosure included.
- Pressure independent

Notes

- 22 Gauge zinc coated steel housing. Mechanically sealed, leak resistant construction.
- Rectangular discharge opening with slip and drive cleat duct connection.
- Assembly ETL certified to UL873.
- Damper blade constructed of two layers of galvanized steel with a sandwiched peripheral gasket.
- 1/2" (13) diameter zinc coated damper shaft with position indicator.
- Units not to be used for temporary heat or ventilation during construction.

Insulation: FF50

- Internal Insulation - Fiber Free Foam 1/2" (13mm) thick, 1.5 lb/cu.ft density, meets requirements of NFPA90A and UL 181
- R-Value=2

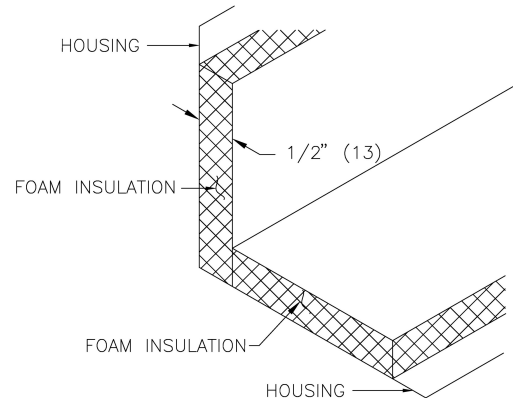

PROJECT: AMN Healthcare Project

ENGINEER:

DESCRIPTION: Single Duct Variable Volume

SDV-1-1//116/FLD///CFM/CLH/FF50//22GA/PS/////0.00/////////0.0/////////20/100/20/100/0/////115-24V/DSW/////////2000

SUBMITTAL NO: 269757-B

CUSTOMER: TD Industries

SUBMITTAL DATE: 12/27/2022

SDV Single Duct

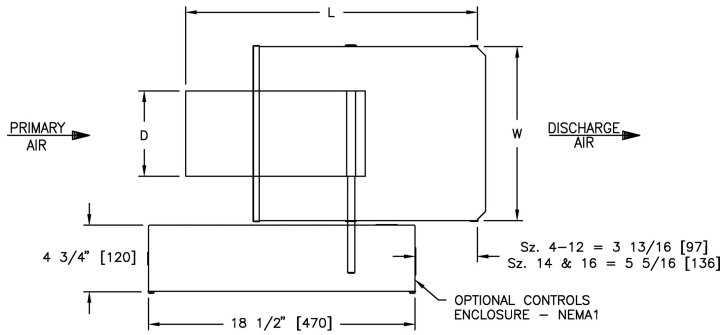

Unit Size	Casing Size	Inlet		Casing		Length
		D	E	W	H	L
12	12	11 7/8	N/A	16	15	20 1/8

Controls Type

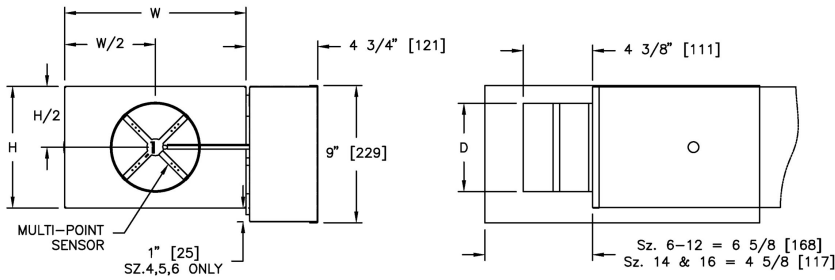

- Multi-point, center averaging airflow sensor.
- For left hand controls, unit orientation is mirrored from main image.
- Controls are supplied by controls contractor and field installed.
- DSW - Disconnect switch included.
- 115-24V control transformer included.
- PS - Nema 1 controls enclosure included.
- Pressure independent

Notes

- 22 Gauge zinc coated steel housing. Mechanically sealed, leak resistant construction.
- Rectangular discharge opening with slip and drive cleat duct connection.
- Assembly ETL certified to UL873.
- Damper blade constructed of two layers of galvanized steel with a sandwiched peripheral gasket.
- 1/2" (13) diameter zinc coated damper shaft with position indicator.
- Units not to be used for temporary heat or ventilation during construction.

Insulation: FF50

- Internal Insulation - Fiber Free Foam 1/2" (13mm) thick, 1.5 lb/cu.ft density, meets requirements of NFPA90A and UL 181
- R-Value=2

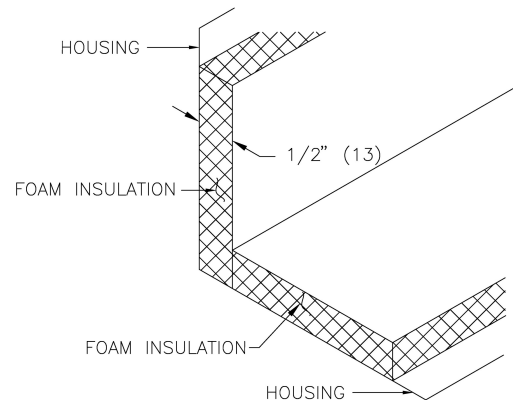

PROJECT: AMN Healthcare Project

ENGINEER:

DESCRIPTION: Single Duct Variable Volume

SDV-1-1//112/FLD//CFM/CLH/FF50//22GA/PS/////0.00//////////0.0//////////224/1120/224/1120/0/////115-24V/DSW//////////2000

SUBMITTAL NO: 269757-B

CUSTOMER: TD Industries

SUBMITTAL DATE: 12/27/2022

SDV Single Duct

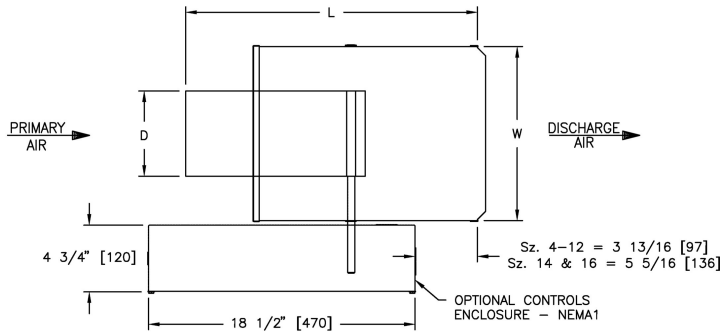

Unit Size	Casing Size	Inlet		Casing		Length
		D	E	W	H	L
8	8	7 7/8	N/A	12	10	20 1/8

Controls Type

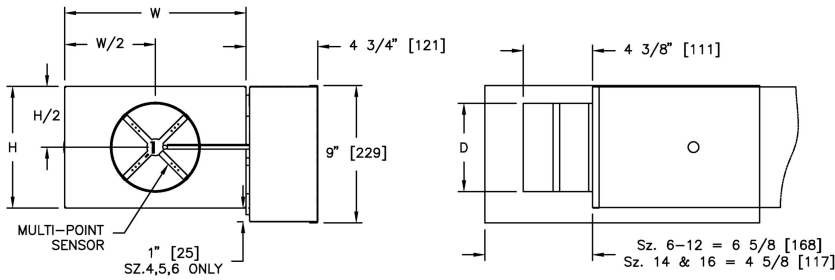

- Multi-point, center averaging airflow sensor.
- Controls enclosure will be supplied as illustrated on right hand side.
- Controls are supplied by controls contractor and field installed.
- DSW - Disconnect switch included.
- 115-24V control transformer included.
- PS - Nema 1 controls enclosure included.
- Pressure independent

Notes

- 22 Gauge zinc coated steel housing. Mechanically sealed, leak resistant construction.
- Rectangular discharge opening with slip and drive cleat duct connection.
- Assembly ETL certified to UL873.
- Damper blade constructed of two layers of galvanized steel with a sandwiched peripheral gasket.
- 1/2" (13) diameter zinc coated damper shaft with position indicator.
- Units not to be used for temporary heat or ventilation during construction.

Insulation: FF50

- Internal Insulation - Fiber Free Foam 1/2" (13mm) thick, 1.5 lb/cu.ft density, meets requirements of NFPA90A and UL 181
- R-Value=2

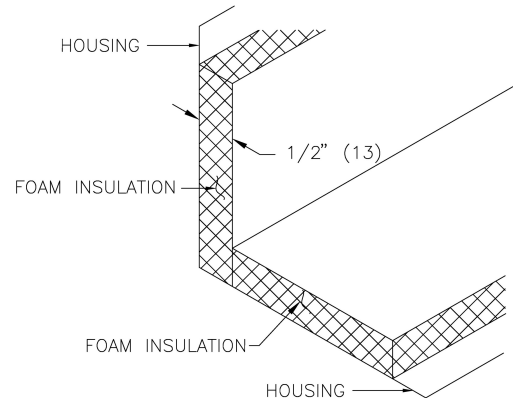

PROJECT: AMN Healthcare Project

ENGINEER:

DESCRIPTION: Single Duct Variable Volume

SDV-1-1/11/8/FLD///CFM/CRH/FF50//22GA/PS/////0.00//////////0.0//////////72/360/72/360/0/////115-24V/DSW//////////2000

SUBMITTAL NO: 269757-B

CUSTOMER: TD Industries

SUBMITTAL DATE: 12/27/2022

SDV Single Duct

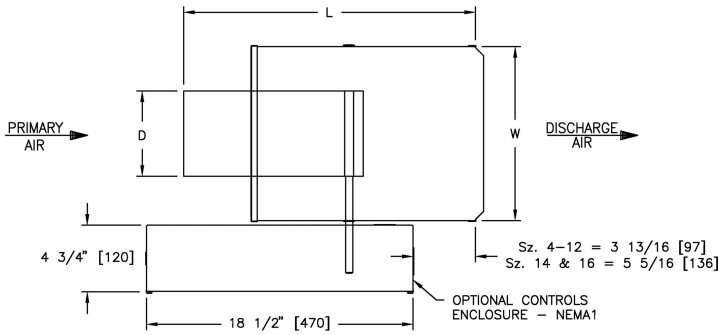

Unit Size	Casing Size	Inlet		Casing		Length
		D	E	W	H	L
12	12	11 7/8	N/A	16	15	20 1/8

Controls Type

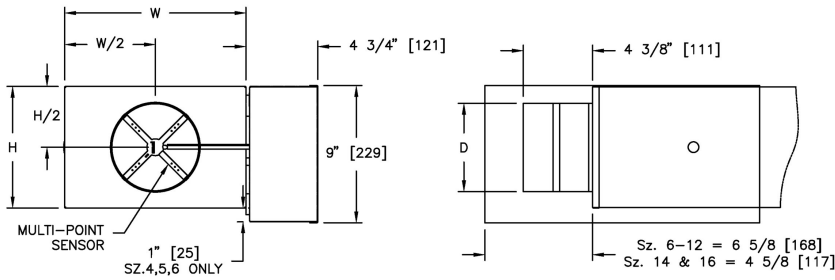

- Multi-point, center averaging airflow sensor.
- For left hand controls, unit orientation is mirrored from main image.
- Controls are supplied by controls contractor and field installed.
- DSW - Disconnect switch included.
- 115-24V control transformer included.
- PS - Nema 1 controls enclosure included.
- Pressure independent

Notes

- 22 Gauge zinc coated steel housing. Mechanically sealed, leak resistant construction.
- Rectangular discharge opening with slip and drive cleat duct connection.
- Assembly ETL certified to UL873.
- Damper blade constructed of two layers of galvanized steel with a sandwiched peripheral gasket.
- 1/2" (13) diameter zinc coated damper shaft with position indicator.
- Units not to be used for temporary heat or ventilation during construction.

Insulation: FF50

- Internal Insulation - Fiber Free Foam 1/2" (13mm) thick, 1.5 lb/cu.ft density, meets requirements of NFPA90A and UL 181
- R-Value=2

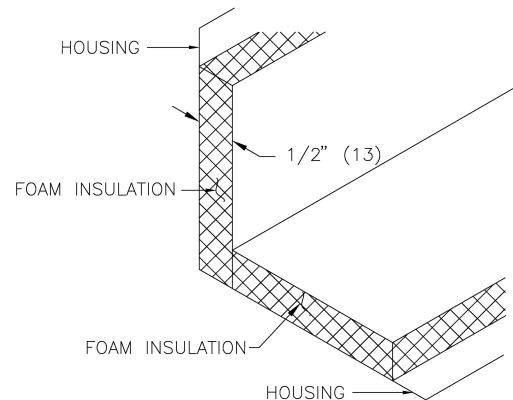

PROJECT: AMN Healthcare Project

ENGINEER:

DESCRIPTION: Single Duct Variable Volume

SDV-1-1//11/12/FLD//CFM/CLH/FF50//22GA/PS/////0.00//////////0.0//////////240/1200/240/1200/0/////115-24V/DSW//////////2000

SUBMITTAL NO: 269757-B

CUSTOMER: TD Industries

SUBMITTAL DATE: 12/27/2022

SDV Single Duct

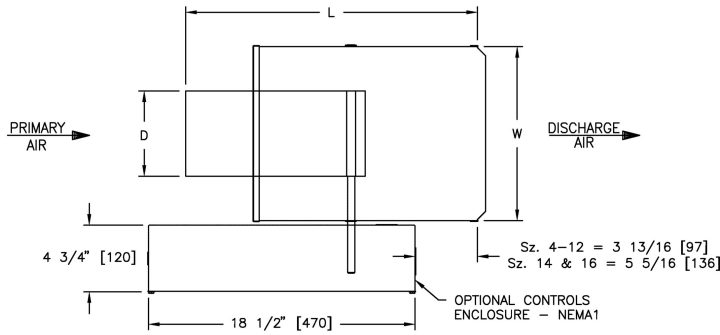

Unit Size	Casing Size	Inlet		Casing		Length
		D	E	W	H	L
12	12	11 7/8	N/A	16	15	20 1/8

Controls Type

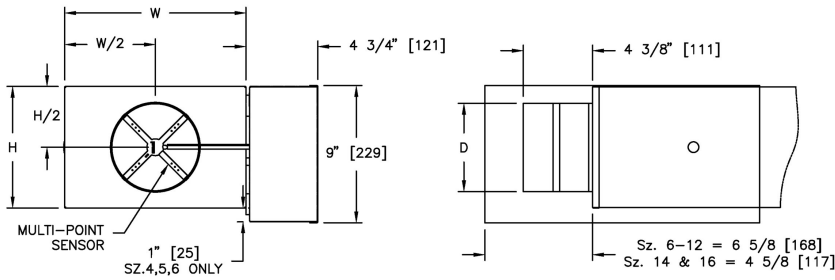

- Multi-point, center averaging airflow sensor.
- For left hand controls, unit orientation is mirrored from main image.
- Controls are supplied by controls contractor and field installed.
- DSW - Disconnect switch included.
- 115-24V control transformer included.
- PS - Nema 1 controls enclosure included.
- Pressure independent

Notes

- 22 Gauge zinc coated steel housing. Mechanically sealed, leak resistant construction.
- Rectangular discharge opening with slip and drive cleat duct connection.
- Assembly ETL certified to UL873.
- Damper blade constructed of two layers of galvanized steel with a sandwiched peripheral gasket.
- 1/2" (13) diameter zinc coated damper shaft with position indicator.
- Units not to be used for temporary heat or ventilation during construction.

Insulation: FF50

- Internal Insulation - Fiber Free Foam 1/2" (13mm) thick, 1.5 lb/cu.ft density, meets requirements of NFPA90A and UL 181
- R-Value=2

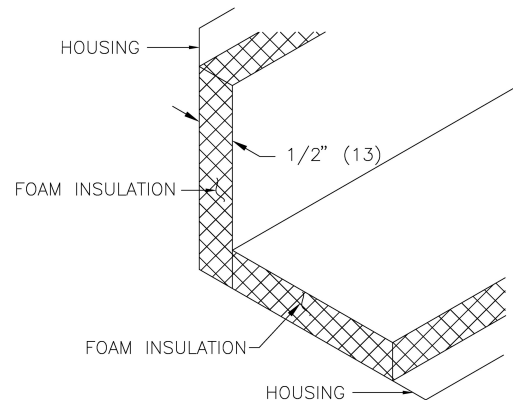

PROJECT: AMN Healthcare Project

ENGINEER:

DESCRIPTION: Single Duct Variable Volume

SDV-1-1//12/FLD//CFM/CLH/FF50//22GA/PS//0.00//0.0//240/1200/200/1000/0//115-24V/DSW//2000

SUBMITTAL NO: 269757-B

CUSTOMER: TD Industries

SUBMITTAL DATE: 12/27/2022

SDV Single Duct

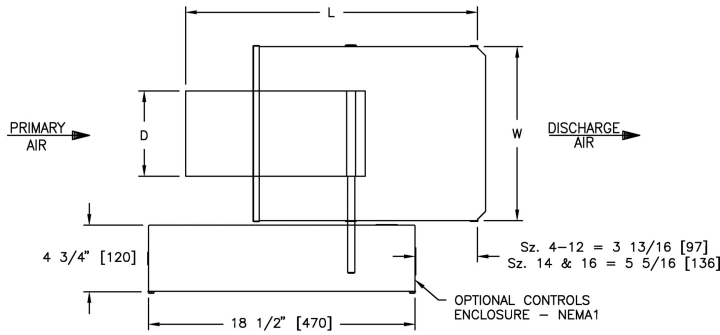

Unit Size	Casing Size	Inlet		Casing		Length
		D	E	W	H	L
12	12	11 7/8	N/A	16	15	20 1/8

Controls Type

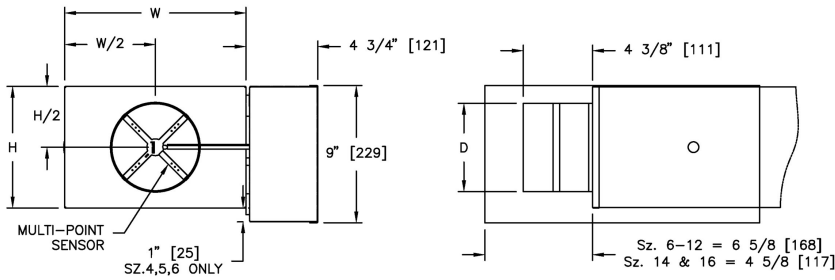

- Multi-point, center averaging airflow sensor.
- Controls enclosure will be supplied as illustrated on right hand side.
- Controls are supplied by controls contractor and field installed.
- DSW - Disconnect switch included.
- 115-24V control transformer included.
- PS - Nema 1 controls enclosure included.
- Pressure independent

Notes

- 22 Gauge zinc coated steel housing. Mechanically sealed, leak resistant construction.
- Rectangular discharge opening with slip and drive cleat duct connection.
- Assembly ETL certified to UL873.
- Damper blade constructed of two layers of galvanized steel with a sandwiched peripheral gasket.
- 1/2" (13) diameter zinc coated damper shaft with position indicator.
- Units not to be used for temporary heat or ventilation during construction.

Insulation: FF50

- Internal Insulation - Fiber Free Foam 1/2" (13mm) thick, 1.5 lb/cu.ft density, meets requirements of NFPA90A and UL 181
- R-Value=2

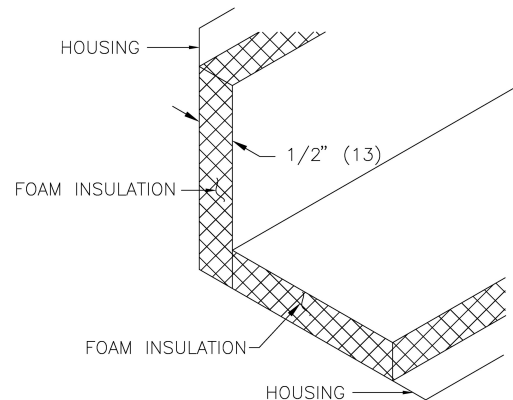

PROJECT: AMN Healthcare Project

ENGINEER:

DESCRIPTION: Single Duct Variable Volume

SDV-1-1//12/FLD//CFM/CRH/FF50//22GA/PS//0.00//0.0//240/1200/240/1200/0//115-24V/DSW//2000

SUBMITTAL NO: 269757-B

CUSTOMER: TD Industries

SUBMITTAL DATE: 12/27/2022

SDV Single Duct

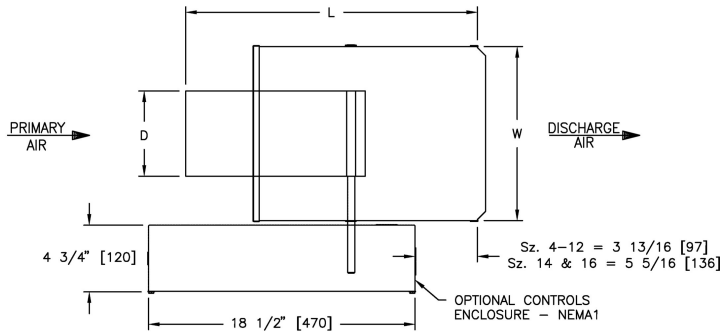

Unit Size	Casing Size	Inlet		Casing		Length
		D	E	W	H	L
10	10	9 7/8	N/A	14	12 1/2	20 1/8

Controls Type

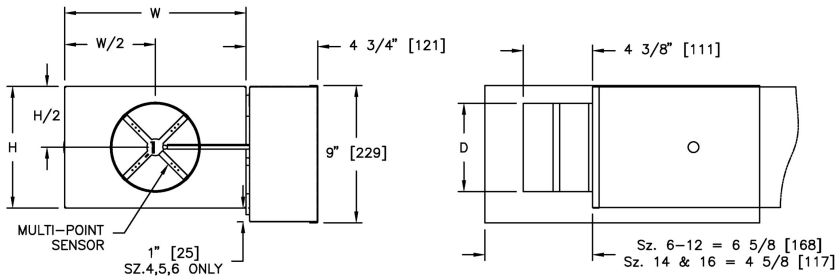

- Multi-point, center averaging airflow sensor.
- For left hand controls, unit orientation is mirrored from main image.
- Controls are supplied by controls contractor and field installed.
- DSW - Disconnect switch included.
- 115-24V control transformer included.
- PS - Nema 1 controls enclosure included.
- Pressure independent

Notes

- 22 Gauge zinc coated steel housing. Mechanically sealed, leak resistant construction.
- Rectangular discharge opening with slip and drive cleat duct connection.
- Assembly ETL certified to UL873.
- Damper blade constructed of two layers of galvanized steel with a sandwiched peripheral gasket.
- 1/2" (13) diameter zinc coated damper shaft with position indicator.
- Units not to be used for temporary heat or ventilation during construction.

Insulation: FF50

- Internal Insulation - Fiber Free Foam 1/2" (13mm) thick, 1.5 lb/cu.ft density, meets requirements of NFPA90A and UL 181
- R-Value=2

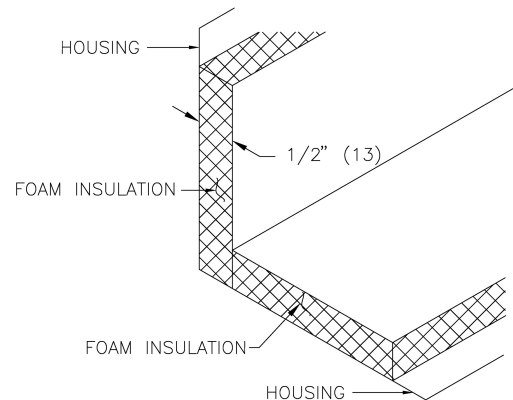

PROJECT: AMN Healthcare Project

ENGINEER:

DESCRIPTION: Single Duct Variable Volume

SDV-1-1//10/FLD//CFM/CLH/FF50//22GA/PS//0.00//0.0//152/760/152/760/0//115-24V/DSW//2000

SUBMITTAL NO: 269757-B

CUSTOMER: TD Industries

SUBMITTAL DATE: 12/27/2022

SDV Single Duct

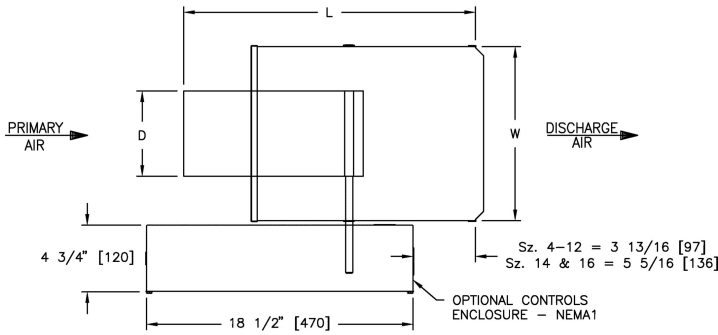

Unit Size	Casing Size	Inlet		Casing		Length
		D	E	W	H	L
6	6	5 7/8	N/A	12	8	20 1/8

Controls Type

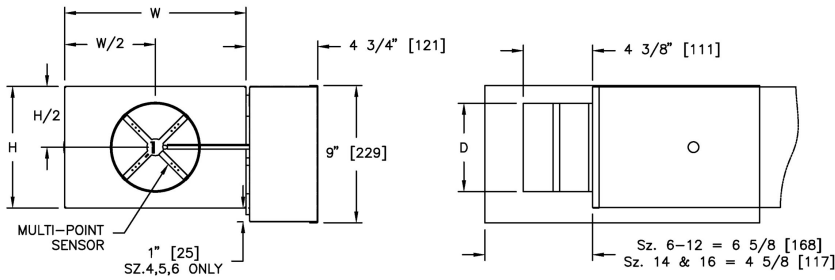

- Multi-point, center averaging airflow sensor.
- For left hand controls, unit orientation is mirrored from main image.
- Controls are supplied by controls contractor and field installed.
- DSW - Disconnect switch included.
- 115-24V control transformer included.
- PS - Nema 1 controls enclosure included.
- Pressure independent

Notes

- 22 Gauge zinc coated steel housing. Mechanically sealed, leak resistant construction.
- Rectangular discharge opening with slip and drive cleat duct connection.
- Assembly ETL certified to UL873.
- Damper blade constructed of two layers of galvanized steel with a sandwiched peripheral gasket.
- 1/2" (13) diameter zinc coated damper shaft with position indicator.
- Units not to be used for temporary heat or ventilation during construction.

Insulation: FF50

- Internal Insulation - Fiber Free Foam 1/2" (13mm) thick, 1.5 lb/cu.ft density, meets requirements of NFPA90A and UL 181
- R-Value=2

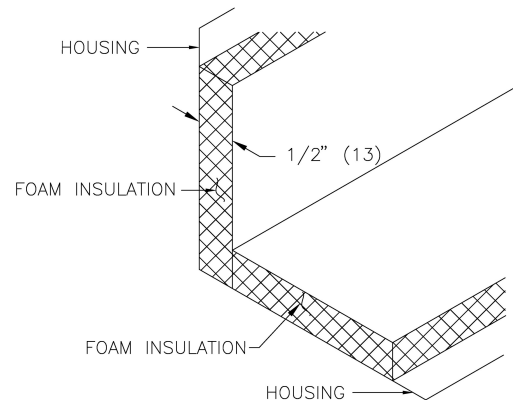

PROJECT: AMN Healthcare Project

ENGINEER:

DESCRIPTION: Single Duct Variable Volume

SDV-1-1//1/6/FLD///CFM/CLH/FF50//22GA/PS/////0.00/////////0.0/////////30/150/30/150/0/////115-24V/DSW/////////2000

SUBMITTAL NO: 269757-B

CUSTOMER: TD Industries

SUBMITTAL DATE: 12/27/2022

SDV Single Duct

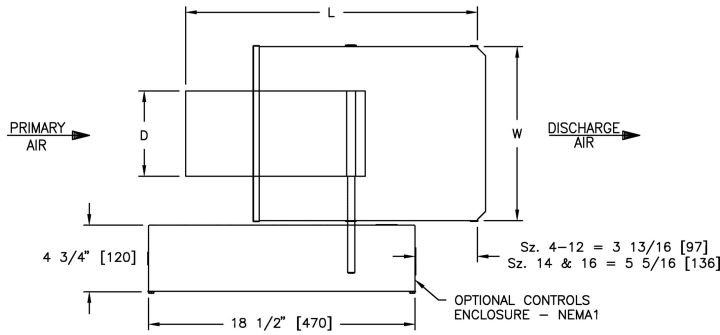

Unit Size	Casing Size	Inlet		Casing		Length
		D	E	W	H	L
6	6	5 7/8	N/A	12	8	20 1/8

Controls Type

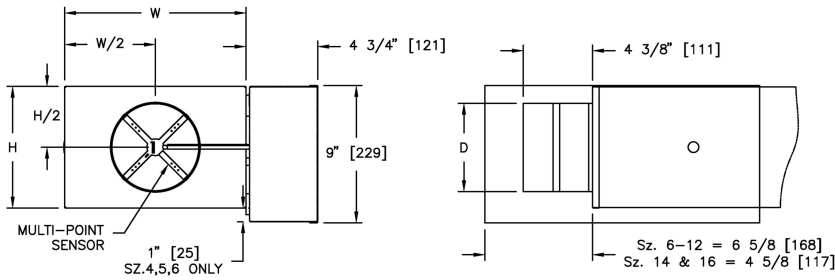

- Multi-point, center averaging airflow sensor.
- Controls enclosure will be supplied as illustrated on right hand side.
- Controls are supplied by controls contractor and field installed.
- DSW - Disconnect switch included.
- 115-24V control transformer included.
- PS - Nema 1 controls enclosure included.
- Pressure independent

Notes

- 22 Gauge zinc coated steel housing. Mechanically sealed, leak resistant construction.
- Rectangular discharge opening with slip and drive cleat duct connection.
- Assembly ETL certified to UL873.
- Damper blade constructed of two layers of galvanized steel with a sandwiched peripheral gasket.
- 1/2" (13) diameter zinc coated damper shaft with position indicator.
- Units not to be used for temporary heat or ventilation during construction.

Insulation: FF50

- Internal Insulation - Fiber Free Foam 1/2" (13mm) thick, 1.5 lb/cu.ft density, meets requirements of NFPA90A and UL 181
- R-Value=2

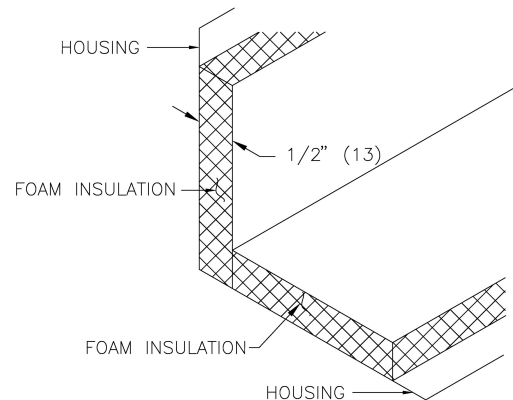

PROJECT: AMN Healthcare Project

ENGINEER:

DESCRIPTION: Single Duct Variable Volume

SDV-1-1/11/6/FLD///CFM/CRH/FF50//22GA/PS/////0.00//////////0.0//////////40/200/40/200/0/////115-24V/DSW//////////2000

SUBMITTAL NO: 269757-B

CUSTOMER: TD Industries

SUBMITTAL DATE: 12/27/2022

SDV Single Duct

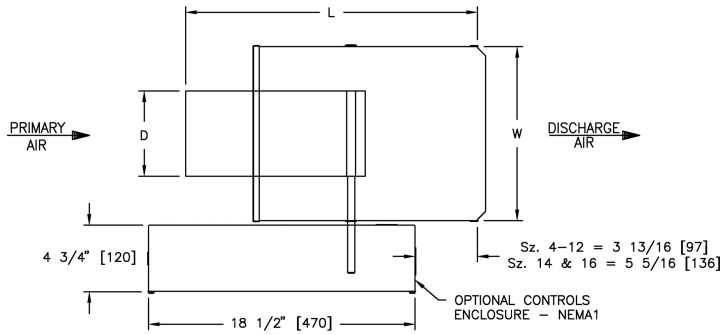

Unit Size	Casing Size	Inlet		Casing		Length
		D	E	W	H	L
12	12	11 7/8	N/A	16	15	20 1/8

Controls Type

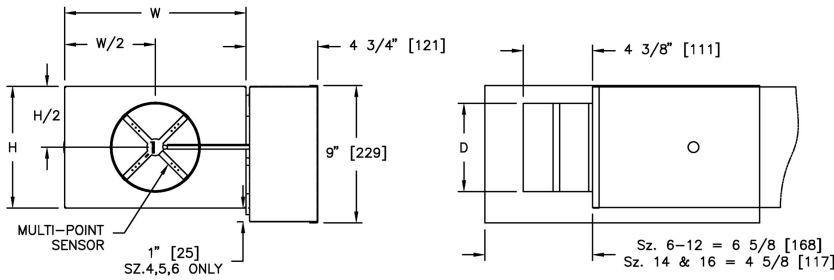

- Multi-point, center averaging airflow sensor.
- For left hand controls, unit orientation is mirrored from main image.
- Controls are supplied by controls contractor and field installed.
- DSW - Disconnect switch included.
- 115-24V control transformer included.
- PS - Nema 1 controls enclosure included.
- Pressure independent

Notes

- 22 Gauge zinc coated steel housing. Mechanically sealed, leak resistant construction.
- Rectangular discharge opening with slip and drive cleat duct connection.
- Assembly ETL certified to UL873.
- Damper blade constructed of two layers of galvanized steel with a sandwiched peripheral gasket.
- 1/2" (13) diameter zinc coated damper shaft with position indicator.
- Units not to be used for temporary heat or ventilation during construction.

Insulation: FF50

- Internal Insulation - Fiber Free Foam 1/2" (13mm) thick, 1.5 lb/cu.ft density, meets requirements of NFPA90A and UL 181
- R-Value=2

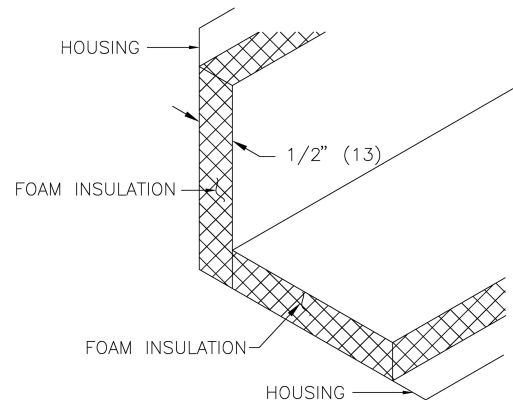

PROJECT: AMN Healthcare Project

ENGINEER:

DESCRIPTION: Single Duct Variable Volume

SDV-1-1//112/FLD//CFM/CLH/FF50//22GA/PS//0.00//0.0//220/1100/220/1100/0//115-24V/DSW//2000

SUBMITTAL NO: 269757-B

CUSTOMER: TD Industries

SUBMITTAL DATE: 12/27/2022

SDV Single Duct

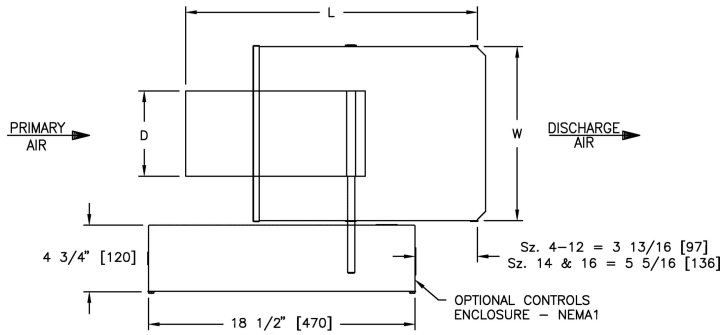

Unit Size	Casing Size	Inlet		Casing		Length
		D	E	W	H	L
6	6	5 7/8	N/A	12	8	20 1/8

Controls Type

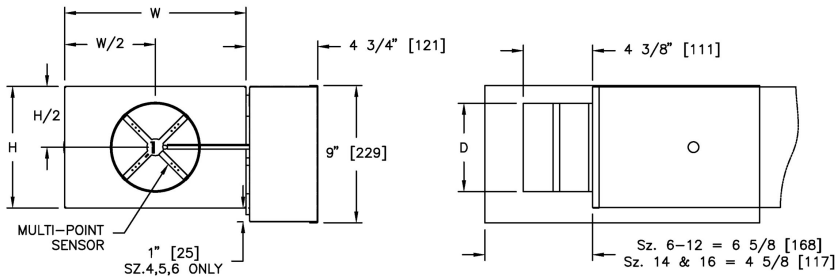

- Multi-point, center averaging airflow sensor.
- For left hand controls, unit orientation is mirrored from main image.
- Controls are supplied by controls contractor and field installed.
- DSW - Disconnect switch included.
- 115-24V control transformer included.
- PS - Nema 1 controls enclosure included.
- Pressure independent

Notes

- 22 Gauge zinc coated steel housing. Mechanically sealed, leak resistant construction.
- Rectangular discharge opening with slip and drive cleat duct connection.
- Assembly ETL certified to UL873.
- Damper blade constructed of two layers of galvanized steel with a sandwiched peripheral gasket.
- 1/2" (13) diameter zinc coated damper shaft with position indicator.
- Units not to be used for temporary heat or ventilation during construction.

Insulation: FF50

- Internal Insulation - Fiber Free Foam 1/2" (13mm) thick, 1.5 lb/cu.ft density, meets requirements of NFPA90A and UL 181
- R-Value=2

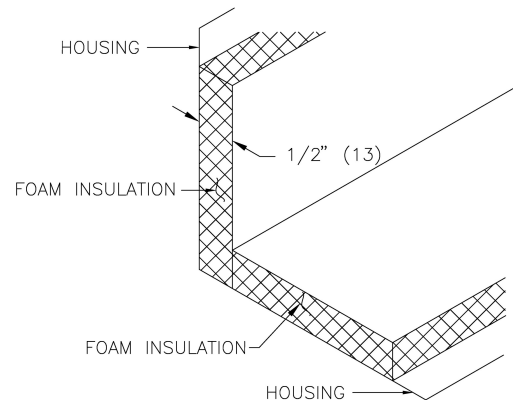

PROJECT: AMN Healthcare Project

ENGINEER:

DESCRIPTION: Single Duct Variable Volume

SDV-1-1/11/6/FLD///CFM/CLH/FF50//22GA/PS/////0.00/////////0.0/////////36/180/36/180/0/////115-24V/DSW/////////2000

SUBMITTAL NO: 269757-B

CUSTOMER: TD Industries

SUBMITTAL DATE: 12/27/2022

SDV Single Duct

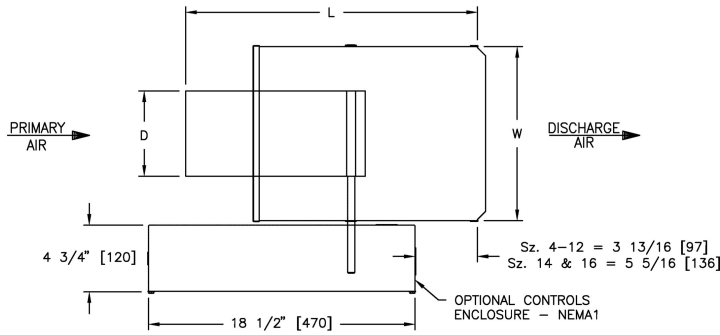

Unit Size	Casing Size	Inlet		Casing		Length
		D	E	W	H	L
6	6	5 7/8	N/A	12	8	20 1/8

Controls Type

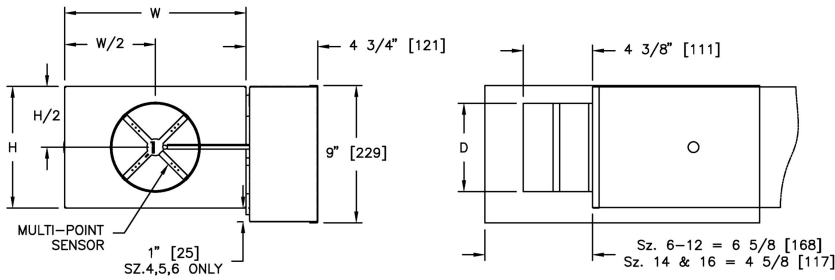

- Multi-point, center averaging airflow sensor.
- For left hand controls, unit orientation is mirrored from main image.
- Controls are supplied by controls contractor and field installed.
- DSW - Disconnect switch included.
- 115-24V control transformer included.
- PS - Nema 1 controls enclosure included.
- Pressure independent

Notes

- 22 Gauge zinc coated steel housing. Mechanically sealed, leak resistant construction.
- Rectangular discharge opening with slip and drive cleat duct connection.
- Assembly ETL certified to UL873.
- Damper blade constructed of two layers of galvanized steel with a sandwiched peripheral gasket.
- 1/2" (13) diameter zinc coated damper shaft with position indicator.
- Units not to be used for temporary heat or ventilation during construction.

Insulation: FF50

- Internal Insulation - Fiber Free Foam 1/2" (13mm) thick, 1.5 lb/cu.ft density, meets requirements of NFPA90A and UL 181
- R-Value=2

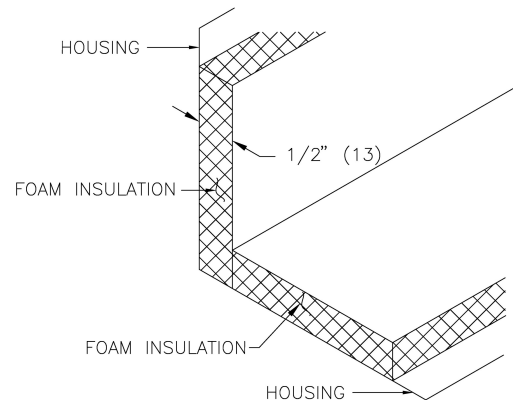

PROJECT: AMN Healthcare Project

ENGINEER:

DESCRIPTION: Single Duct Variable Volume

SDV-1-1/11/6/FLD///CFM/CLH/FF50//22GA/PS/////0.00/////////0.0/////////26/130/26/130/0/////115-24V/DSW/////////2000

SUBMITTAL NO: 269757-B

CUSTOMER: TD Industries

SUBMITTAL DATE: 12/27/2022

SDV Single Duct

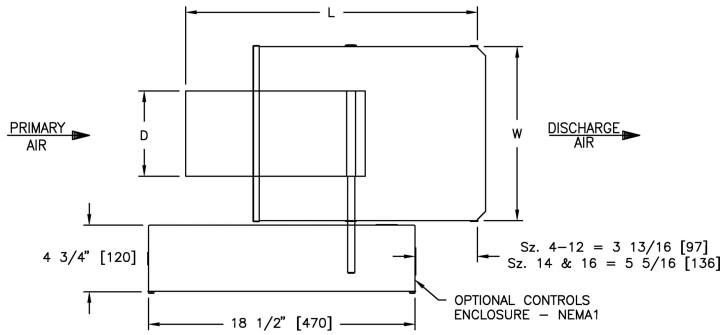

Unit Size	Casing Size	Inlet		Casing		Length
		D	E	W	H	L
10	10	9 7/8	N/A	14	12 1/2	20 1/8

Controls Type

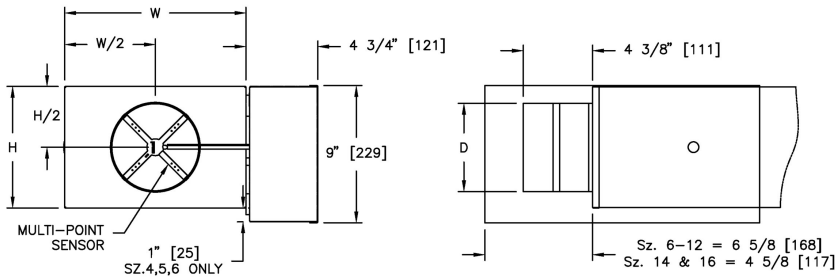

- Multi-point, center averaging airflow sensor.
- For left hand controls, unit orientation is mirrored from main image.
- Controls are supplied by controls contractor and field installed.
- DSW - Disconnect switch included.
- 115-24V control transformer included.
- PS - Nema 1 controls enclosure included.
- Pressure independent

Notes

- 22 Gauge zinc coated steel housing. Mechanically sealed, leak resistant construction.
- Rectangular discharge opening with slip and drive cleat duct connection.
- Assembly ETL certified to UL873.
- Damper blade constructed of two layers of galvanized steel with a sandwiched peripheral gasket.
- 1/2" (13) diameter zinc coated damper shaft with position indicator.
- Units not to be used for temporary heat or ventilation during construction.

Insulation: FF50

- Internal Insulation - Fiber Free Foam 1/2" (13mm) thick, 1.5 lb/cu.ft density, meets requirements of NFPA90A and UL 181
- R-Value=2

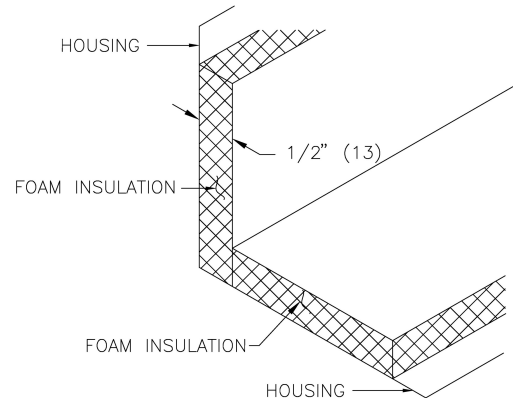

PROJECT: AMN Healthcare Project

ENGINEER:

DESCRIPTION: Single Duct Variable Volume

SDV-1-1//10/FLD//CFM/CLH/FF50//22GA/PS//0.00//0.0//140/700/26/130/0//115-24V/DSW//2000

SUBMITTAL NO: 269757-B

CUSTOMER: TD Industries

SUBMITTAL DATE: 12/27/2022

PRICE ALL-IN-ONE

Terminal Unit Selection - SDV

Project: AMN Healthcare Project Location: Dallas, TX
 Tag: 5-1 Quantity: 1

Altitude: 0 (ft)

Model: SDV

Selection

Model	Size	Primary (CFM)		Static Pressure (in. w.g.)				Electrical	
	Unit	Max	Min	Inlet SP	Downstream SP	Differential PD	Min Oper. PD	MCA	MOP
SDV	8	310	62	1.00	0.25	0.75	0.01	N/A	N/A

Sound Performance

Max Radiated Sound Power Levels (dB)							Max Radiated NC	Max Discharge Sound Power Levels (dB)							Max Discharge NC
Octave Band								Octave Band							
2	3	4	5	6	7	2		3	4	5	6	7			
48	41	33	28	27	21	--	65	58	47	45	41	42	--		

Accessories

Terminal Liner : FF50

Accessory 2 : CLH

Accessory 6 : DSW

Performance Notes:

- Dashes (--) indicate NC values less than 20.
- NC values are calculated based on procedures outlined in AHRI Standard 885-2008, "A Procedure for Estimating Occupied Space Sound Levels in the Application of Air Terminals and Air Outlets."
- Sound power levels are given in decibels (dB).
- Dashes (--) indicate sound power levels below 36-29-26-22-19-17 for each octave band; values below these sound power levels are considered below significance per AHRI 880.
- Minimum operating pressure is the minimum static pressure required to operate the terminal item assembly at maximum primary flow with a wide open damper.
- NC values are derived from sound power levels obtained in accordance with ASHRAE Standard 130-2016 and AHRI Standard 880-2017, which include duct end reflection corrections.
- Terminal item assembly is ETL certified in accordance with UL1995 and CSA 22.2.236.

The Results of this program are only an aid to the designer, and are not a substitute for professional design services.
 Price Industries accepts no liability for the adequacy of any resulting design or installation. All data subject to change without notice.

PRICE ALL-IN-ONE

Terminal Unit Selection - SDV

Project: AMN Healthcare Project Location: Dallas, TX
 Tag: 5-2 Quantity: 1

Altitude: 0 (ft)

Model: SDV

Selection

Model	Size	Primary (CFM)		Static Pressure (in. w.g.)				Electrical	
	Unit	Max	Min	Inlet SP	Downstream SP	Differential PD	Min Oper. PD	MCA	MOP
SDV	12	1140	228	1.00	0.25	0.75	0.01	N/A	N/A

Sound Performance

Max Radiated Sound Power Levels (dB)							Max Radiated NC	Max Discharge Sound Power Levels (dB)							Max Discharge NC
Octave Band								Octave Band							
2	3	4	5	6	7	2		3	4	5	6	7			
54	46	44	36	34	28	--	67	62	56	54	50	49	--		

Accessories

Terminal Liner : FF50

Accessory 2 : CLH

Accessory 6 : DSW

Performance Notes:

- Dashes (--) indicate NC values less than 20.
- NC values are calculated based on procedures outlined in AHRI Standard 885-2008, "A Procedure for Estimating Occupied Space Sound Levels in the Application of Air Terminals and Air Outlets."
- Sound power levels are given in decibels (dB).
- Dashes (--) indicate sound power levels below 36-29-26-22-19-17 for each octave band; values below these sound power levels are considered below significance per AHRI 880.
- Minimum operating pressure is the minimum static pressure required to operate the terminal item assembly at maximum primary flow with a wide open damper.
- NC values are derived from sound power levels obtained in accordance with ASHRAE Standard 130-2016 and AHRI Standard 880-2017, which include duct end reflection corrections.
- Terminal item assembly is ETL certified in accordance with UL1995 and CSA 22.2.236.

The Results of this program are only an aid to the designer, and are not a substitute for professional design services.
 Price Industries accepts no liability for the adequacy of any resulting design or installation. All data subject to change without notice.

PRICE ALL-IN-ONE

Terminal Unit Selection - SDV

Project: AMN Healthcare Project Location: Dallas, TX
 Tag: 5-3 Quantity: 1

Altitude: 0 (ft)

Model: SDV

Selection

Model	Size	Primary (CFM)		Static Pressure (in. w.g.)				Electrical	
	Unit	Max	Min	Inlet SP	Downstream SP	Differential PD	Min Oper. PD	MCA	MOP
SDV	10	720	144	1.00	0.25	0.75	0.01	N/A	N/A

Sound Performance

Max Radiated Sound Power Levels (dB)							Max Radiated NC	Max Discharge Sound Power Levels (dB)							Max Discharge NC
Octave Band								Octave Band							
2	3	4	5	6	7	2		3	4	5	6	7			
54	46	40	34	31	27	--	68	61	53	51	47	46	--		

Accessories

Terminal Liner : FF50

Accessory 2 : CRH

Accessory 6 : DSW

Performance Notes:

- Dashes (--) indicate NC values less than 20.
- NC values are calculated based on procedures outlined in AHRI Standard 885-2008, "A Procedure for Estimating Occupied Space Sound Levels in the Application of Air Terminals and Air Outlets."
- Sound power levels are given in decibels (dB).
- Dashes (--) indicate sound power levels below 36-29-26-22-19-17 for each octave band; values below these sound power levels are considered below significance per AHRI 880.
- Minimum operating pressure is the minimum static pressure required to operate the terminal item assembly at maximum primary flow with a wide open damper.
- NC values are derived from sound power levels obtained in accordance with ASHRAE Standard 130-2016 and AHRI Standard 880-2017, which include duct end reflection corrections.
- Terminal item assembly is ETL certified in accordance with UL1995 and CSA 22.2.236.

The Results of this program are only an aid to the designer, and are not a substitute for professional design services.
 Price Industries accepts no liability for the adequacy of any resulting design or installation. All data subject to change without notice.

PRICE ALL-IN-ONE

Terminal Unit Selection - SDV

Project: AMN Healthcare Project Location: Dallas, TX
 Tag: 5-4 Quantity: 1

Altitude: 0 (ft)

Model: SDV

Selection

Model	Size	Primary (CFM)		Static Pressure (in. w.g.)				Electrical	
	Unit	Max	Min	Inlet SP	Downstream SP	Differential PD	Min Oper. PD	MCA	MOP
SDV	6	230	46	1.00	0.25	0.75	0.05	N/A	N/A

Sound Performance

Max Radiated Sound Power Levels (dB)						Max Radiated NC	Max Discharge Sound Power Levels (dB)						Max Discharge NC
Octave Band							Octave Band						
2	3	4	5	6	7		2	3	4	5	6	7	
54	47	38	32	29	23	--	69	64	55	51	45	44	26 (2)

Accessories

Terminal Liner : FF50

Accessory 2 : CRH

Accessory 6 : DSW

Performance Notes:

- Dashes (--) indicate NC values less than 20.
- NC values are calculated based on procedures outlined in AHRI Standard 885-2008, "A Procedure for Estimating Occupied Space Sound Levels in the Application of Air Terminals and Air Outlets."
- Sound power levels are given in decibels (dB).
- Dashes (--) indicate sound power levels below 36-29-26-22-19-17 for each octave band; values below these sound power levels are considered below significance per AHRI 880.
- Minimum operating pressure is the minimum static pressure required to operate the terminal item assembly at maximum primary flow with a wide open damper.
- NC values are derived from sound power levels obtained in accordance with ASHRAE Standard 130-2016 and AHRI Standard 880-2017, which include duct end reflection corrections.
- Terminal item assembly is ETL certified in accordance with UL1995 and CSA 22.2.236.

The Results of this program are only an aid to the designer, and are not a substitute for professional design services.
 Price Industries accepts no liability for the adequacy of any resulting design or installation. All data subject to change without notice.

PRICE ALL-IN-ONE

Terminal Unit Selection - SDV

Project: AMN Healthcare Project Location: Dallas, TX
 Tag: 5-5 Quantity: 1

Altitude: 0 (ft)

Model: SDV

Selection

Model	Size	Primary (CFM)		Static Pressure (in. w.g.)				Electrical	
	Unit	Max	Min	Inlet SP	Downstream SP	Differential PD	Min Oper. PD	MCA	MOP
SDV	8	520	104	1.00	0.25	0.75	0.01	N/A	N/A

Sound Performance

Max Radiated Sound Power Levels (dB)						Max Radiated NC	Max Discharge Sound Power Levels (dB)						Max Discharge NC
Octave Band							Octave Band						
2	3	4	5	6	7		2	3	4	5	6	7	
55	47	40	34	31	25	--	70	64	54	52	46	46	24 (2)

Accessories

Terminal Liner : FF50

Accessory 2 : CLH

Accessory 6 : DSW

Performance Notes:

- Dashes (--) indicate NC values less than 20.
- NC values are calculated based on procedures outlined in AHRI Standard 885-2008, "A Procedure for Estimating Occupied Space Sound Levels in the Application of Air Terminals and Air Outlets."
- Sound power levels are given in decibels (dB).
- Dashes (--) indicate sound power levels below 36-29-26-22-19-17 for each octave band; values below these sound power levels are considered below significance per AHRI 880.
- Minimum operating pressure is the minimum static pressure required to operate the terminal item assembly at maximum primary flow with a wide open damper.
- NC values are derived from sound power levels obtained in accordance with ASHRAE Standard 130-2016 and AHRI Standard 880-2017, which include duct end reflection corrections.
- Terminal item assembly is ETL certified in accordance with UL1995 and CSA 22.2.236.

The Results of this program are only an aid to the designer, and are not a substitute for professional design services.
 Price Industries accepts no liability for the adequacy of any resulting design or installation. All data subject to change without notice.

PRICE ALL-IN-ONE

Terminal Unit Selection - SDV

Project: AMN Healthcare Project Location: Dallas, TX
 Tag: 5-6 Quantity: 1

Altitude: 0 (ft)

Model: SDV

Selection

Model	Size	Primary (CFM)		Static Pressure (in. w.g.)				Electrical	
	Unit	Max	Min	Inlet SP	Downstream SP	Differential PD	Min Oper. PD	MCA	MOP
SDV	6	240	48	1.00	0.25	0.75	0.05	N/A	N/A

Sound Performance

Max Radiated Sound Power Levels (dB)						Max Radiated NC	Max Discharge Sound Power Levels (dB)						Max Discharge NC
Octave Band							Octave Band						
2	3	4	5	6	7		2	3	4	5	6	7	
54	47	39	32	29	24	--	70	64	56	52	45	44	28 (2)

Accessories

Terminal Liner : FF50

Accessory 2 : CRH

Accessory 6 : DSW

Performance Notes:

- Dashes (--) indicate NC values less than 20.
- NC values are calculated based on procedures outlined in AHRI Standard 885-2008, "A Procedure for Estimating Occupied Space Sound Levels in the Application of Air Terminals and Air Outlets."
- Sound power levels are given in decibels (dB).
- Dashes (--) indicate sound power levels below 36-29-26-22-19-17 for each octave band; values below these sound power levels are considered below significance per AHRI 880.
- Minimum operating pressure is the minimum static pressure required to operate the terminal item assembly at maximum primary flow with a wide open damper.
- NC values are derived from sound power levels obtained in accordance with ASHRAE Standard 130-2016 and AHRI Standard 880-2017, which include duct end reflection corrections.
- Terminal item assembly is ETL certified in accordance with UL1995 and CSA 22.2.236.

The Results of this program are only an aid to the designer, and are not a substitute for professional design services.
 Price Industries accepts no liability for the adequacy of any resulting design or installation. All data subject to change without notice.

PRICE ALL-IN-ONE

Terminal Unit Selection - SDV

Project: AMN Healthcare Project Location: Dallas, TX
 Tag: 5-7 Quantity: 1

Altitude: 0 (ft)

Model: SDV

Selection

Model	Size	Primary (CFM)		Static Pressure (in. w.g.)				Electrical	
	Unit	Max	Min	Inlet SP	Downstream SP	Differential PD	Min Oper. PD	MCA	MOP
SDV	6	240	48	1.00	0.25	0.75	0.05	N/A	N/A

Sound Performance

Max Radiated Sound Power Levels (dB)						Max Radiated NC	Max Discharge Sound Power Levels (dB)						Max Discharge NC
Octave Band							Octave Band						
2	3	4	5	6	7		2	3	4	5	6	7	
54	47	39	32	29	24	--	70	64	56	52	45	44	28 (2)

Accessories

Terminal Liner : FF50

Accessory 2 : CLH

Accessory 6 : DSW

Performance Notes:

- Dashes (--) indicate NC values less than 20.
- NC values are calculated based on procedures outlined in AHRI Standard 885-2008, "A Procedure for Estimating Occupied Space Sound Levels in the Application of Air Terminals and Air Outlets."
- Sound power levels are given in decibels (dB).
- Dashes (--) indicate sound power levels below 36-29-26-22-19-17 for each octave band; values below these sound power levels are considered below significance per AHRI 880.
- Minimum operating pressure is the minimum static pressure required to operate the terminal item assembly at maximum primary flow with a wide open damper.
- NC values are derived from sound power levels obtained in accordance with ASHRAE Standard 130-2016 and AHRI Standard 880-2017, which include duct end reflection corrections.
- Terminal item assembly is ETL certified in accordance with UL1995 and CSA 22.2.236.

The Results of this program are only an aid to the designer, and are not a substitute for professional design services.
 Price Industries accepts no liability for the adequacy of any resulting design or installation. All data subject to change without notice.

PRICE ALL-IN-ONE

Terminal Unit Selection - SDV

Project: AMN Healthcare Project Location: Dallas, TX
 Tag: 5-8 Quantity: 1

Altitude: 0 (ft)

Model: SDV

Selection

Model	Size	Primary (CFM)		Static Pressure (in. w.g.)				Electrical	
	Unit	Max	Min	Inlet SP	Downstream SP	Differential PD	Min Oper. PD	MCA	MOP
SDV	10	810	162	1.00	0.25	0.75	0.01	N/A	N/A

Sound Performance

Max Radiated Sound Power Levels (dB)							Max Radiated NC	Max Discharge Sound Power Levels (dB)							Max Discharge NC
Octave Band								Octave Band							
2	3	4	5	6	7	2		3	4	5	6	7			
55	47	42	35	32	28	--	69	62	54	53	47	47	20 (2)		

Accessories

Terminal Liner : FF50

Accessory 2 : CLH

Accessory 6 : DSW

Performance Notes:

- Dashes (--) indicate NC values less than 20.
- NC values are calculated based on procedures outlined in AHRI Standard 885-2008, "A Procedure for Estimating Occupied Space Sound Levels in the Application of Air Terminals and Air Outlets."
- Sound power levels are given in decibels (dB).
- Dashes (--) indicate sound power levels below 36-29-26-22-19-17 for each octave band; values below these sound power levels are considered below significance per AHRI 880.
- Minimum operating pressure is the minimum static pressure required to operate the terminal item assembly at maximum primary flow with a wide open damper.
- NC values are derived from sound power levels obtained in accordance with ASHRAE Standard 130-2016 and AHRI Standard 880-2017, which include duct end reflection corrections.
- Terminal item assembly is ETL certified in accordance with UL1995 and CSA 22.2.236.

The Results of this program are only an aid to the designer, and are not a substitute for professional design services.
 Price Industries accepts no liability for the adequacy of any resulting design or installation. All data subject to change without notice.

PRICE ALL-IN-ONE

Terminal Unit Selection - SDV

Project: AMN Healthcare Project Location: Dallas, TX
 Tag: 5-9 Quantity: 1

Altitude: 0 (ft)

Model: SDV

Selection

Model	Size	Primary (CFM)		Static Pressure (in. w.g.)				Electrical	
	Unit	Max	Min	Inlet SP	Downstream SP	Differential PD	Min Oper. PD	MCA	MOP
SDV	6	225	45	1.00	0.25	0.75	0.05	N/A	N/A

Sound Performance

Max Radiated Sound Power Levels (dB)						Max Radiated NC	Max Discharge Sound Power Levels (dB)						Max Discharge NC
Octave Band							Octave Band						
2	3	4	5	6	7		2	3	4	5	6	7	
53	46	38	32	29	23	--	69	63	55	51	44	44	26 (2)

Accessories

Terminal Liner : FF50

Accessory 2 : CRH

Accessory 6 : DSW

Performance Notes:

- Dashes (--) indicate NC values less than 20.
- NC values are calculated based on procedures outlined in AHRI Standard 885-2008, "A Procedure for Estimating Occupied Space Sound Levels in the Application of Air Terminals and Air Outlets."
- Sound power levels are given in decibels (dB).
- Dashes (--) indicate sound power levels below 36-29-26-22-19-17 for each octave band; values below these sound power levels are considered below significance per AHRI 880.
- Minimum operating pressure is the minimum static pressure required to operate the terminal item assembly at maximum primary flow with a wide open damper.
- NC values are derived from sound power levels obtained in accordance with ASHRAE Standard 130-2016 and AHRI Standard 880-2017, which include duct end reflection corrections.
- Terminal item assembly is ETL certified in accordance with UL1995 and CSA 22.2.236.

The Results of this program are only an aid to the designer, and are not a substitute for professional design services.
 Price Industries accepts no liability for the adequacy of any resulting design or installation. All data subject to change without notice.

PRICE ALL-IN-ONE

Terminal Unit Selection - SDV

Project: AMN Healthcare Project Location: Dallas, TX
 Tag: 5-10 Quantity: 1

Altitude: 0 (ft)

Model: SDV

Selection

Model	Size	Primary (CFM)		Static Pressure (in. w.g.)				Electrical	
	Unit	Max	Min	Inlet SP	Downstream SP	Differential PD	Min Oper. PD	MCA	MOP
SDV	8	260	52	1.00	0.25	0.75	0.01	N/A	N/A

Sound Performance

Max Radiated Sound Power Levels (dB)						Max Radiated NC	Max Discharge Sound Power Levels (dB)						Max Discharge NC
Octave Band							Octave Band						
2	3	4	5	6	7		2	3	4	5	6	7	
46	39	31	26	25	20	--	63	57	45	43	40	40	--

Accessories

Terminal Liner : FF50

Accessory 2 : CLH

Accessory 6 : DSW

Performance Notes:

- Dashes (--) indicate NC values less than 20.
- NC values are calculated based on procedures outlined in AHRI Standard 885-2008, "A Procedure for Estimating Occupied Space Sound Levels in the Application of Air Terminals and Air Outlets."
- Sound power levels are given in decibels (dB).
- Dashes (--) indicate sound power levels below 36-29-26-22-19-17 for each octave band; values below these sound power levels are considered below significance per AHRI 880.
- Minimum operating pressure is the minimum static pressure required to operate the terminal item assembly at maximum primary flow with a wide open damper.
- NC values are derived from sound power levels obtained in accordance with ASHRAE Standard 130-2016 and AHRI Standard 880-2017, which include duct end reflection corrections.
- Terminal item assembly is ETL certified in accordance with UL1995 and CSA 22.2.236.

The Results of this program are only an aid to the designer, and are not a substitute for professional design services.
 Price Industries accepts no liability for the adequacy of any resulting design or installation. All data subject to change without notice.

PRICE ALL-IN-ONE

Terminal Unit Selection - SDV

Project: AMN Healthcare Project
Tag: 5-11

Location: Dallas, TX
Quantity: 1

Altitude: 0 (ft)

Model: SDV

Selection

Model	Size	Primary (CFM)		Static Pressure (in. w.g.)				Electrical	
	Unit	Max	Min	Inlet SP	Downstream SP	Differential PD	Min Oper. PD	MCA	MOP
SDV	8	435	87	1.00	0.25	0.75	0.01	N/A	N/A

Sound Performance

Max Radiated Sound Power Levels (dB)							Max Radiated NC	Max Discharge Sound Power Levels (dB)							Max Discharge NC
Octave Band								Octave Band							
2	3	4	5	6	7	2		3	4	5	6	7			
53	45	37	32	29	23	--	69	62	52	49	45	45	22 (2)		

Accessories

Terminal Liner : FF50

Accessory 2 : CRH

Accessory 6 : DSW

Performance Notes:

- Dashes (--) indicate NC values less than 20.
- NC values are calculated based on procedures outlined in AHRI Standard 885-2008, "A Procedure for Estimating Occupied Space Sound Levels in the Application of Air Terminals and Air Outlets."
- Sound power levels are given in decibels (dB).
- Dashes (--) indicate sound power levels below 36-29-26-22-19-17 for each octave band; values below these sound power levels are considered below significance per AHRI 880.
- Minimum operating pressure is the minimum static pressure required to operate the terminal item assembly at maximum primary flow with a wide open damper.
- NC values are derived from sound power levels obtained in accordance with ASHRAE Standard 130-2016 and AHRI Standard 880-2017, which include duct end reflection corrections.
- Terminal item assembly is ETL certified in accordance with UL1995 and CSA 22.2.236.

The Results of this program are only an aid to the designer, and are not a substitute for professional design services.
Price Industries accepts no liability for the adequacy of any resulting design or installation. All data subject to change without notice.

PRICE ALL-IN-ONE

Terminal Unit Selection - SDV

Project: AMN Healthcare Project
Tag: 5-12

Location: Dallas, TX
Quantity: 1

Altitude: 0 (ft)

Model: SDV

Selection

Model	Size	Primary (CFM)		Static Pressure (in. w.g.)				Electrical	
	Unit	Max	Min	Inlet SP	Downstream SP	Differential PD	Min Oper. PD	MCA	MOP
SDV	8	440	88	1.00	0.25	0.75	0.01	N/A	N/A

Sound Performance

Max Radiated Sound Power Levels (dB)						Max Radiated NC	Max Discharge Sound Power Levels (dB)						Max Discharge NC
Octave Band							Octave Band						
2	3	4	5	6	7		2	3	4	5	6	7	
53	45	38	32	29	23	--	69	62	52	49	45	45	22 (2)

Accessories

Terminal Liner : FF50

Accessory 2 : CLH

Accessory 6 : DSW

Performance Notes:

- Dashes (--) indicate NC values less than 20.
- NC values are calculated based on procedures outlined in AHRI Standard 885-2008, "A Procedure for Estimating Occupied Space Sound Levels in the Application of Air Terminals and Air Outlets."
- Sound power levels are given in decibels (dB).
- Dashes (--) indicate sound power levels below 36-29-26-22-19-17 for each octave band; values below these sound power levels are considered below significance per AHRI 880.
- Minimum operating pressure is the minimum static pressure required to operate the terminal item assembly at maximum primary flow with a wide open damper.
- NC values are derived from sound power levels obtained in accordance with ASHRAE Standard 130-2016 and AHRI Standard 880-2017, which include duct end reflection corrections.
- Terminal item assembly is ETL certified in accordance with UL1995 and CSA 22.2.236.

The Results of this program are only an aid to the designer, and are not a substitute for professional design services.
Price Industries accepts no liability for the adequacy of any resulting design or installation. All data subject to change without notice.

PRICE ALL-IN-ONE

Terminal Unit Selection - SDV

Project: AMN Healthcare Project
Tag: 5-13

Location: Dallas, TX
Quantity: 1

Altitude: 0 (ft)

Model: SDV

Selection

Model	Size	Primary (CFM)		Static Pressure (in. w.g.)				Electrical	
	Unit	Max	Min	Inlet SP	Downstream SP	Differential PD	Min Oper. PD	MCA	MOP
SDV	8	440	88	1.00	0.25	0.75	0.01	N/A	N/A

Sound Performance

Max Radiated Sound Power Levels (dB)							Max Radiated NC	Max Discharge Sound Power Levels (dB)							Max Discharge NC
Octave Band								Octave Band							
2	3	4	5	6	7	2		3	4	5	6	7			
53	45	38	32	29	23	--	69	62	52	49	45	45	22 (2)		

Accessories

Terminal Liner : FF50

Accessory 2 : CLH

Accessory 6 : DSW

Performance Notes:

- Dashes (--) indicate NC values less than 20.
- NC values are calculated based on procedures outlined in AHRI Standard 885-2008, "A Procedure for Estimating Occupied Space Sound Levels in the Application of Air Terminals and Air Outlets."
- Sound power levels are given in decibels (dB).
- Dashes (--) indicate sound power levels below 36-29-26-22-19-17 for each octave band; values below these sound power levels are considered below significance per AHRI 880.
- Minimum operating pressure is the minimum static pressure required to operate the terminal item assembly at maximum primary flow with a wide open damper.
- NC values are derived from sound power levels obtained in accordance with ASHRAE Standard 130-2016 and AHRI Standard 880-2017, which include duct end reflection corrections.
- Terminal item assembly is ETL certified in accordance with UL1995 and CSA 22.2.236.

The Results of this program are only an aid to the designer, and are not a substitute for professional design services.
Price Industries accepts no liability for the adequacy of any resulting design or installation. All data subject to change without notice.

PRICE ALL-IN-ONE

Terminal Unit Selection - SDV

Project: AMN Healthcare Project Location: Dallas, TX
 Tag: 5-14 Quantity: 1

Altitude: 0 (ft)

Model: SDV

Selection

Model	Size	Primary (CFM)		Static Pressure (in. w.g.)				Electrical	
	Unit	Max	Min	Inlet SP	Downstream SP	Differential PD	Min Oper. PD	MCA	MOP
SDV	8	490	98	1.00	0.25	0.75	0.01	N/A	N/A

Sound Performance

Max Radiated Sound Power Levels (dB)						Max Radiated NC	Max Discharge Sound Power Levels (dB)						Max Discharge NC
Octave Band							Octave Band						
2	3	4	5	6	7		2	3	4	5	6	7	
54	46	39	33	30	24	--	70	63	53	51	46	45	24 (2)

Accessories

Terminal Liner : FF50

Accessory 2 : CRH

Accessory 6 : DSW

Performance Notes:

- Dashes (--) indicate NC values less than 20.
- NC values are calculated based on procedures outlined in AHRI Standard 885-2008, "A Procedure for Estimating Occupied Space Sound Levels in the Application of Air Terminals and Air Outlets."
- Sound power levels are given in decibels (dB).
- Dashes (--) indicate sound power levels below 36-29-26-22-19-17 for each octave band; values below these sound power levels are considered below significance per AHRI 880.
- Minimum operating pressure is the minimum static pressure required to operate the terminal item assembly at maximum primary flow with a wide open damper.
- NC values are derived from sound power levels obtained in accordance with ASHRAE Standard 130-2016 and AHRI Standard 880-2017, which include duct end reflection corrections.
- Terminal item assembly is ETL certified in accordance with UL1995 and CSA 22.2.236.

The Results of this program are only an aid to the designer, and are not a substitute for professional design services.
 Price Industries accepts no liability for the adequacy of any resulting design or installation. All data subject to change without notice.

PRICE ALL-IN-ONE

Terminal Unit Selection - SDV

Project: AMN Healthcare Project Location: Dallas, TX
 Tag: 5-15 Quantity: 1

Altitude: 0 (ft)

Model: SDV

Selection

Model	Size	Primary (CFM)		Static Pressure (in. w.g.)				Electrical	
	Unit	Max	Min	Inlet SP	Downstream SP	Differential PD	Min Oper. PD	MCA	MOP
SDV	8	540	108	1.00	0.25	0.75	0.01	N/A	N/A

Sound Performance

Max Radiated Sound Power Levels (dB)						Max Radiated NC	Max Discharge Sound Power Levels (dB)						Max Discharge NC
Octave Band							Octave Band						
2	3	4	5	6	7		2	3	4	5	6	7	
55	47	40	34	31	25	--	71	64	55	52	47	46	25 (2)

Accessories

Terminal Liner : FF50

Accessory 2 : CLH

Accessory 6 : DSW

Performance Notes:

- Dashes (--) indicate NC values less than 20.
- NC values are calculated based on procedures outlined in AHRI Standard 885-2008, "A Procedure for Estimating Occupied Space Sound Levels in the Application of Air Terminals and Air Outlets."
- Sound power levels are given in decibels (dB).
- Dashes (--) indicate sound power levels below 36-29-26-22-19-17 for each octave band; values below these sound power levels are considered below significance per AHRI 880.
- Minimum operating pressure is the minimum static pressure required to operate the terminal item assembly at maximum primary flow with a wide open damper.
- NC values are derived from sound power levels obtained in accordance with ASHRAE Standard 130-2016 and AHRI Standard 880-2017, which include duct end reflection corrections.
- Terminal item assembly is ETL certified in accordance with UL1995 and CSA 22.2.236.

The Results of this program are only an aid to the designer, and are not a substitute for professional design services.
 Price Industries accepts no liability for the adequacy of any resulting design or installation. All data subject to change without notice.

PRICE ALL-IN-ONE

Terminal Unit Selection - SDV

Project: AMN Healthcare Project **Location:** Dallas, TX
Tag: 5-16 **Quantity:** 1

Altitude: 0 (ft)

Model: SDV

Selection

Model	Size	Primary (CFM)		Static Pressure (in. w.g.)				Electrical	
	Unit	Max	Min	Inlet SP	Downstream SP	Differential PD	Min Oper. PD	MCA	MOP
SDV	6	160	32	1.00	0.25	0.75	0.02	N/A	N/A

Sound Performance

Max Radiated Sound Power Levels (dB)						Max Radiated NC	Max Discharge Sound Power Levels (dB)						Max Discharge NC
Octave Band							Octave Band						
2	3	4	5	6	7		2	3	4	5	6	7	
50	42	33	28	26	22	--	65	59	51	47	41	41	21 (2)

Accessories

Terminal Liner : FF50

Accessory 2 : CLH

Accessory 6 : DSW

Performance Notes:

- Dashes (--) indicate NC values less than 20.
- NC values are calculated based on procedures outlined in AHRI Standard 885-2008, "A Procedure for Estimating Occupied Space Sound Levels in the Application of Air Terminals and Air Outlets."
- Sound power levels are given in decibels (dB).
- Dashes (--) indicate sound power levels below 36-29-26-22-19-17 for each octave band; values below these sound power levels are considered below significance per AHRI 880.
- Minimum operating pressure is the minimum static pressure required to operate the terminal item assembly at maximum primary flow with a wide open damper.
- NC values are derived from sound power levels obtained in accordance with ASHRAE Standard 130-2016 and AHRI Standard 880-2017, which include duct end reflection corrections.
- Terminal item assembly is ETL certified in accordance with UL1995 and CSA 22.2.236.

The Results of this program are only an aid to the designer, and are not a substitute for professional design services.
 Price Industries accepts no liability for the adequacy of any resulting design or installation. All data subject to change without notice.

PRICE ALL-IN-ONE

Terminal Unit Selection - SDV

Project: AMN Healthcare Project Location: Dallas, TX
 Tag: 5-17 Quantity: 1

Altitude: 0 (ft)

Model: SDV

Selection

Model	Size	Primary (CFM)		Static Pressure (in. w.g.)				Electrical	
	Unit	Max	Min	Inlet SP	Downstream SP	Differential PD	Min Oper. PD	MCA	MOP
SDV	8	260	52	1.00	0.25	0.75	0.01	N/A	N/A

Sound Performance

Max Radiated Sound Power Levels (dB)						Max Radiated NC	Max Discharge Sound Power Levels (dB)						Max Discharge NC
Octave Band							Octave Band						
2	3	4	5	6	7		2	3	4	5	6	7	
46	39	31	26	25	20	--	63	57	45	43	40	40	--

Accessories

Terminal Liner : FF50

Accessory 2 : CLH

Accessory 6 : DSW

Performance Notes:

- Dashes (--) indicate NC values less than 20.
- NC values are calculated based on procedures outlined in AHRI Standard 885-2008, "A Procedure for Estimating Occupied Space Sound Levels in the Application of Air Terminals and Air Outlets."
- Sound power levels are given in decibels (dB).
- Dashes (--) indicate sound power levels below 36-29-26-22-19-17 for each octave band; values below these sound power levels are considered below significance per AHRI 880.
- Minimum operating pressure is the minimum static pressure required to operate the terminal item assembly at maximum primary flow with a wide open damper.
- NC values are derived from sound power levels obtained in accordance with ASHRAE Standard 130-2016 and AHRI Standard 880-2017, which include duct end reflection corrections.
- Terminal item assembly is ETL certified in accordance with UL1995 and CSA 22.2.236.

The Results of this program are only an aid to the designer, and are not a substitute for professional design services.
 Price Industries accepts no liability for the adequacy of any resulting design or installation. All data subject to change without notice.

PRICE ALL-IN-ONE

Terminal Unit Selection - SDV

Project: AMN Healthcare Project Location: Dallas, TX
 Tag: 5-18 Quantity: 1

Altitude: 0 (ft)

Model: SDV

Selection

Model	Size	Primary (CFM)		Static Pressure (in. w.g.)				Electrical	
	Unit	Max	Min	Inlet SP	Downstream SP	Differential PD	Min Oper. PD	MCA	MOP
SDV	8	260	52	1.00	0.25	0.75	0.01	N/A	N/A

Sound Performance

Max Radiated Sound Power Levels (dB)						Max Radiated NC	Max Discharge Sound Power Levels (dB)						Max Discharge NC
Octave Band							Octave Band						
2	3	4	5	6	7		2	3	4	5	6	7	
46	39	31	26	25	20	--	63	57	45	43	40	40	--

Accessories

Terminal Liner : FF50

Accessory 2 : CRH

Accessory 6 : DSW

Performance Notes:

- Dashes (--) indicate NC values less than 20.
- NC values are calculated based on procedures outlined in AHRI Standard 885-2008, "A Procedure for Estimating Occupied Space Sound Levels in the Application of Air Terminals and Air Outlets."
- Sound power levels are given in decibels (dB).
- Dashes (--) indicate sound power levels below 36-29-26-22-19-17 for each octave band; values below these sound power levels are considered below significance per AHRI 880.
- Minimum operating pressure is the minimum static pressure required to operate the terminal item assembly at maximum primary flow with a wide open damper.
- NC values are derived from sound power levels obtained in accordance with ASHRAE Standard 130-2016 and AHRI Standard 880-2017, which include duct end reflection corrections.
- Terminal item assembly is ETL certified in accordance with UL1995 and CSA 22.2.236.

The Results of this program are only an aid to the designer, and are not a substitute for professional design services.
 Price Industries accepts no liability for the adequacy of any resulting design or installation. All data subject to change without notice.

PRICE ALL-IN-ONE

Terminal Unit Selection - SDV

Project: AMN Healthcare Project Location: Dallas, TX
 Tag: 6-1 Quantity: 1

Altitude: 0 (ft)

Model: SDV

Selection

Model	Size	Primary (CFM)		Static Pressure (in. w.g.)				Electrical	
	Unit	Max	Min	Inlet SP	Downstream SP	Differential PD	Min Oper. PD	MCA	MOP
SDV	12	1440	288	1.00	0.25	0.75	0.01	N/A	N/A

Sound Performance

Max Radiated Sound Power Levels (dB)						Max Radiated NC	Max Discharge Sound Power Levels (dB)						Max Discharge NC
Octave Band							Octave Band						
2	3	4	5	6	7		2	3	4	5	6	7	
56	48	46	38	35	29	20 (4)	69	63	59	56	52	50	20 (3)

Accessories

Terminal Liner : FF50

Accessory 2 : CLH

Accessory 6 : DSW

Performance Notes:

- Dashes (--) indicate NC values less than 20.
- NC values are calculated based on procedures outlined in AHRI Standard 885-2008, "A Procedure for Estimating Occupied Space Sound Levels in the Application of Air Terminals and Air Outlets."
- Sound power levels are given in decibels (dB).
- Dashes (--) indicate sound power levels below 36-29-26-22-19-17 for each octave band; values below these sound power levels are considered below significance per AHRI 880.
- Minimum operating pressure is the minimum static pressure required to operate the terminal item assembly at maximum primary flow with a wide open damper.
- NC values are derived from sound power levels obtained in accordance with ASHRAE Standard 130-2016 and AHRI Standard 880-2017, which include duct end reflection corrections.
- Terminal item assembly is ETL certified in accordance with UL1995 and CSA 22.2.236.

The Results of this program are only an aid to the designer, and are not a substitute for professional design services.
 Price Industries accepts no liability for the adequacy of any resulting design or installation. All data subject to change without notice.

PRICE ALL-IN-ONE

Terminal Unit Selection - SDV

Project: AMN Healthcare Project Location: Dallas, TX
 Tag: 6-2 Quantity: 1

Altitude: 0 (ft)

Model: SDV

Selection

Model	Size	Primary (CFM)		Static Pressure (in. w.g.)				Electrical	
	Unit	Max	Min	Inlet SP	Downstream SP	Differential PD	Min Oper. PD	MCA	MOP
SDV	6	100	20	1.00	0.25	0.75	0.01	N/A	N/A

Sound Performance

Max Radiated Sound Power Levels (dB)						Max Radiated NC	Max Discharge Sound Power Levels (dB)						Max Discharge NC
Octave Band							Octave Band						
2	3	4	5	6	7		2	3	4	5	6	7	
45	36	27	22	23	20	--	60	54	45	41	37	38	--

Accessories

Terminal Liner : FF50

Accessory 2 : CLH

Accessory 6 : DSW

Performance Notes:

- Dashes (--) indicate NC values less than 20.
- NC values are calculated based on procedures outlined in AHRI Standard 885-2008, "A Procedure for Estimating Occupied Space Sound Levels in the Application of Air Terminals and Air Outlets."
- Sound power levels are given in decibels (dB).
- Dashes (--) indicate sound power levels below 36-29-26-22-19-17 for each octave band; values below these sound power levels are considered below significance per AHRI 880.
- Minimum operating pressure is the minimum static pressure required to operate the terminal item assembly at maximum primary flow with a wide open damper.
- NC values are derived from sound power levels obtained in accordance with ASHRAE Standard 130-2016 and AHRI Standard 880-2017, which include duct end reflection corrections.
- Terminal item assembly is ETL certified in accordance with UL1995 and CSA 22.2.236.

The Results of this program are only an aid to the designer, and are not a substitute for professional design services.
 Price Industries accepts no liability for the adequacy of any resulting design or installation. All data subject to change without notice.

PRICE ALL-IN-ONE

Terminal Unit Selection - SDV

Project: AMN Healthcare Project Location: Dallas, TX
 Tag: 6-3 Quantity: 1

Altitude: 0 (ft)

Model: SDV

Selection

Model	Size	Primary (CFM)		Static Pressure (in. w.g.)				Electrical	
	Unit	Max	Min	Inlet SP	Downstream SP	Differential PD	Min Oper. PD	MCA	MOP
SDV	12	1120	224	1.00	0.25	0.75	0.01	N/A	N/A

Sound Performance

Max Radiated Sound Power Levels (dB)							Max Radiated NC	Max Discharge Sound Power Levels (dB)							Max Discharge NC
Octave Band								Octave Band							
2	3	4	5	6	7	2		3	4	5	6	7			
54	46	44	36	34	28	--	67	62	56	54	50	49	--		

Accessories

Terminal Liner : FF50

Accessory 2 : CLH

Accessory 6 : DSW

Performance Notes:

- Dashes (--) indicate NC values less than 20.
- NC values are calculated based on procedures outlined in AHRI Standard 885-2008, "A Procedure for Estimating Occupied Space Sound Levels in the Application of Air Terminals and Air Outlets."
- Sound power levels are given in decibels (dB).
- Dashes (--) indicate sound power levels below 36-29-26-22-19-17 for each octave band; values below these sound power levels are considered below significance per AHRI 880.
- Minimum operating pressure is the minimum static pressure required to operate the terminal item assembly at maximum primary flow with a wide open damper.
- NC values are derived from sound power levels obtained in accordance with ASHRAE Standard 130-2016 and AHRI Standard 880-2017, which include duct end reflection corrections.
- Terminal item assembly is ETL certified in accordance with UL1995 and CSA 22.2.236.

The Results of this program are only an aid to the designer, and are not a substitute for professional design services.
 Price Industries accepts no liability for the adequacy of any resulting design or installation. All data subject to change without notice.

PRICE ALL-IN-ONE

Terminal Unit Selection - SDV

Project: AMN Healthcare Project Location: Dallas, TX
 Tag: 6-4 Quantity: 1

Altitude: 0 (ft)

Model: SDV

Selection

Model	Size	Primary (CFM)		Static Pressure (in. w.g.)				Electrical	
	Unit	Max	Min	Inlet SP	Downstream SP	Differential PD	Min Oper. PD	MCA	MOP
SDV	8	360	72	1.00	0.25	0.75	0.01	N/A	N/A

Sound Performance

Max Radiated Sound Power Levels (dB)						Max Radiated NC	Max Discharge Sound Power Levels (dB)						Max Discharge NC
Octave Band							Octave Band						
2	3	4	5	6	7		2	3	4	5	6	7	
50	42	35	30	28	22	--	67	60	49	47	43	43	20 (2)

Accessories

Terminal Liner : FF50

Accessory 2 : CRH

Accessory 6 : DSW

Performance Notes:

- Dashes (--) indicate NC values less than 20.
- NC values are calculated based on procedures outlined in AHRI Standard 885-2008, "A Procedure for Estimating Occupied Space Sound Levels in the Application of Air Terminals and Air Outlets."
- Sound power levels are given in decibels (dB).
- Dashes (--) indicate sound power levels below 36-29-26-22-19-17 for each octave band; values below these sound power levels are considered below significance per AHRI 880.
- Minimum operating pressure is the minimum static pressure required to operate the terminal item assembly at maximum primary flow with a wide open damper.
- NC values are derived from sound power levels obtained in accordance with ASHRAE Standard 130-2016 and AHRI Standard 880-2017, which include duct end reflection corrections.
- Terminal item assembly is ETL certified in accordance with UL1995 and CSA 22.2.236.

The Results of this program are only an aid to the designer, and are not a substitute for professional design services.
 Price Industries accepts no liability for the adequacy of any resulting design or installation. All data subject to change without notice.

PRICE ALL-IN-ONE

Terminal Unit Selection - SDV

Project: AMN Healthcare Project Location: Dallas, TX
 Tag: 6-5 Quantity: 1

Altitude: 0 (ft)

Model: SDV

Selection

Model	Size	Primary (CFM)		Static Pressure (in. w.g.)				Electrical	
	Unit	Max	Min	Inlet SP	Downstream SP	Differential PD	Min Oper. PD	MCA	MOP
SDV	12	1200	240	1.00	0.25	0.75	0.01	N/A	N/A

Sound Performance

Max Radiated Sound Power Levels (dB)						Max Radiated NC	Max Discharge Sound Power Levels (dB)						Max Discharge NC
Octave Band							Octave Band						
2	3	4	5	6	7		2	3	4	5	6	7	
55	47	44	36	34	28	--	68	62	57	55	51	49	--

Accessories

Terminal Liner : FF50

Accessory 2 : CLH

Accessory 6 : DSW

Performance Notes:

- Dashes (--) indicate NC values less than 20.
- NC values are calculated based on procedures outlined in AHRI Standard 885-2008, "A Procedure for Estimating Occupied Space Sound Levels in the Application of Air Terminals and Air Outlets."
- Sound power levels are given in decibels (dB).
- Dashes (--) indicate sound power levels below 36-29-26-22-19-17 for each octave band; values below these sound power levels are considered below significance per AHRI 880.
- Minimum operating pressure is the minimum static pressure required to operate the terminal item assembly at maximum primary flow with a wide open damper.
- NC values are derived from sound power levels obtained in accordance with ASHRAE Standard 130-2016 and AHRI Standard 880-2017, which include duct end reflection corrections.
- Terminal item assembly is ETL certified in accordance with UL1995 and CSA 22.2.236.

The Results of this program are only an aid to the designer, and are not a substitute for professional design services.
 Price Industries accepts no liability for the adequacy of any resulting design or installation. All data subject to change without notice.

PRICE ALL-IN-ONE

Terminal Unit Selection - SDV

Project: AMN Healthcare Project Location: Dallas, TX
 Tag: 6-6 Quantity: 1

Altitude: 0 (ft)

Model: SDV

Selection

Model	Size	Primary (CFM)		Static Pressure (in. w.g.)				Electrical	
	Unit	Max	Min	Inlet SP	Downstream SP	Differential PD	Min Oper. PD	MCA	MOP
SDV	12	1200	240	1.00	0.25	0.75	0.01	N/A	N/A

Sound Performance

Max Radiated Sound Power Levels (dB)						Max Radiated NC	Max Discharge Sound Power Levels (dB)						Max Discharge NC
Octave Band							Octave Band						
2	3	4	5	6	7		2	3	4	5	6	7	
55	47	44	36	34	28	--	68	62	57	55	51	49	--

Accessories

Terminal Liner : FF50

Accessory 2 : CLH

Accessory 6 : DSW

Performance Notes:

- Dashes (--) indicate NC values less than 20.
- NC values are calculated based on procedures outlined in AHRI Standard 885-2008, "A Procedure for Estimating Occupied Space Sound Levels in the Application of Air Terminals and Air Outlets."
- Sound power levels are given in decibels (dB).
- Dashes (--) indicate sound power levels below 36-29-26-22-19-17 for each octave band; values below these sound power levels are considered below significance per AHRI 880.
- Minimum operating pressure is the minimum static pressure required to operate the terminal item assembly at maximum primary flow with a wide open damper.
- NC values are derived from sound power levels obtained in accordance with ASHRAE Standard 130-2016 and AHRI Standard 880-2017, which include duct end reflection corrections.
- Terminal item assembly is ETL certified in accordance with UL1995 and CSA 22.2.236.

The Results of this program are only an aid to the designer, and are not a substitute for professional design services.
 Price Industries accepts no liability for the adequacy of any resulting design or installation. All data subject to change without notice.

PRICE ALL-IN-ONE

Terminal Unit Selection - SDV

Project: AMN Healthcare Project Location: Dallas, TX
 Tag: 6-7 Quantity: 1

Altitude: 0 (ft)

Model: SDV

Selection

Model	Size	Primary (CFM)		Static Pressure (in. w.g.)				Electrical	
	Unit	Max	Min	Inlet SP	Downstream SP	Differential PD	Min Oper. PD	MCA	MOP
SDV	12	1200	240	1.00	0.25	0.75	0.01	N/A	N/A

Sound Performance

Max Radiated Sound Power Levels (dB)						Max Radiated NC	Max Discharge Sound Power Levels (dB)						Max Discharge NC
Octave Band							Octave Band						
2	3	4	5	6	7		2	3	4	5	6	7	
55	47	44	36	34	28	--	68	62	57	55	51	49	--

Accessories

Terminal Liner : FF50

Accessory 2 : CRH

Accessory 6 : DSW

Performance Notes:

- Dashes (--) indicate NC values less than 20.
- NC values are calculated based on procedures outlined in AHRI Standard 885-2008, "A Procedure for Estimating Occupied Space Sound Levels in the Application of Air Terminals and Air Outlets."
- Sound power levels are given in decibels (dB).
- Dashes (--) indicate sound power levels below 36-29-26-22-19-17 for each octave band; values below these sound power levels are considered below significance per AHRI 880.
- Minimum operating pressure is the minimum static pressure required to operate the terminal item assembly at maximum primary flow with a wide open damper.
- NC values are derived from sound power levels obtained in accordance with ASHRAE Standard 130-2016 and AHRI Standard 880-2017, which include duct end reflection corrections.
- Terminal item assembly is ETL certified in accordance with UL1995 and CSA 22.2.236.

The Results of this program are only an aid to the designer, and are not a substitute for professional design services.
 Price Industries accepts no liability for the adequacy of any resulting design or installation. All data subject to change without notice.

PRICE ALL-IN-ONE

Terminal Unit Selection - SDV

Project: AMN Healthcare Project Location: Dallas, TX
 Tag: 6-8 Quantity: 1

Altitude: 0 (ft)

Model: SDV

Selection

Model	Size	Primary (CFM)		Static Pressure (in. w.g.)				Electrical	
	Unit	Max	Min	Inlet SP	Downstream SP	Differential PD	Min Oper. PD	MCA	MOP
SDV	10	760	152	1.00	0.25	0.75	0.01	N/A	N/A

Sound Performance

Max Radiated Sound Power Levels (dB)							Max Radiated NC	Max Discharge Sound Power Levels (dB)							Max Discharge NC
Octave Band								Octave Band							
2	3	4	5	6	7	2		3	4	5	6	7			
55	46	41	35	31	28	--	68	61	54	52	47	47	--		

Accessories

Terminal Liner : FF50

Accessory 2 : CLH

Accessory 6 : DSW

Performance Notes:

- Dashes (--) indicate NC values less than 20.
- NC values are calculated based on procedures outlined in AHRI Standard 885-2008, "A Procedure for Estimating Occupied Space Sound Levels in the Application of Air Terminals and Air Outlets."
- Sound power levels are given in decibels (dB).
- Dashes (--) indicate sound power levels below 36-29-26-22-19-17 for each octave band; values below these sound power levels are considered below significance per AHRI 880.
- Minimum operating pressure is the minimum static pressure required to operate the terminal item assembly at maximum primary flow with a wide open damper.
- NC values are derived from sound power levels obtained in accordance with ASHRAE Standard 130-2016 and AHRI Standard 880-2017, which include duct end reflection corrections.
- Terminal item assembly is ETL certified in accordance with UL1995 and CSA 22.2.236.

The Results of this program are only an aid to the designer, and are not a substitute for professional design services.
 Price Industries accepts no liability for the adequacy of any resulting design or installation. All data subject to change without notice.

PRICE ALL-IN-ONE

Terminal Unit Selection - SDV

Project: AMN Healthcare Project Location: Dallas, TX
 Tag: 6-9 Quantity: 1

Altitude: 0 (ft)

Model: SDV

Selection

Model	Size	Primary (CFM)		Static Pressure (in. w.g.)				Electrical	
	Unit	Max	Min	Inlet SP	Downstream SP	Differential PD	Min Oper. PD	MCA	MOP
SDV	6	150	30	1.00	0.25	0.75	0.02	N/A	N/A

Sound Performance

Max Radiated Sound Power Levels (dB)							Max Radiated NC	Max Discharge Sound Power Levels (dB)							Max Discharge NC
Octave Band								Octave Band							
2	3	4	5	6	7	2		3	4	5	6	7			
49	41	32	27	26	21	--	65	59	50	46	41	41	21 (2)		

Accessories

Terminal Liner : FF50

Accessory 2 : CLH

Accessory 6 : DSW

Performance Notes:

- Dashes (--) indicate NC values less than 20.
- NC values are calculated based on procedures outlined in AHRI Standard 885-2008, "A Procedure for Estimating Occupied Space Sound Levels in the Application of Air Terminals and Air Outlets."
- Sound power levels are given in decibels (dB).
- Dashes (--) indicate sound power levels below 36-29-26-22-19-17 for each octave band; values below these sound power levels are considered below significance per AHRI 880.
- Minimum operating pressure is the minimum static pressure required to operate the terminal item assembly at maximum primary flow with a wide open damper.
- NC values are derived from sound power levels obtained in accordance with ASHRAE Standard 130-2016 and AHRI Standard 880-2017, which include duct end reflection corrections.
- Terminal item assembly is ETL certified in accordance with UL1995 and CSA 22.2.236.

The Results of this program are only an aid to the designer, and are not a substitute for professional design services.
 Price Industries accepts no liability for the adequacy of any resulting design or installation. All data subject to change without notice.

PRICE ALL-IN-ONE

Terminal Unit Selection - SDV

Project: AMN Healthcare Project Location: Dallas, TX
 Tag: 6-10 Quantity: 1

Altitude: 0 (ft)

Model: SDV

Selection

Model	Size	Primary (CFM)		Static Pressure (in. w.g.)				Electrical	
	Unit	Max	Min	Inlet SP	Downstream SP	Differential PD	Min Oper. PD	MCA	MOP
SDV	6	200	40	1.00	0.25	0.75	0.04	N/A	N/A

Sound Performance

Max Radiated Sound Power Levels (dB)						Max Radiated NC	Max Discharge Sound Power Levels (dB)						Max Discharge NC
Octave Band							Octave Band						
2	3	4	5	6	7		2	3	4	5	6	7	
52	45	36	30	28	23	--	68	62	54	50	43	43	25 (2)

Accessories

Terminal Liner : FF50

Accessory 2 : CRH

Accessory 6 : DSW

Performance Notes:

- Dashes (--) indicate NC values less than 20.
- NC values are calculated based on procedures outlined in AHRI Standard 885-2008, "A Procedure for Estimating Occupied Space Sound Levels in the Application of Air Terminals and Air Outlets."
- Sound power levels are given in decibels (dB).
- Dashes (--) indicate sound power levels below 36-29-26-22-19-17 for each octave band; values below these sound power levels are considered below significance per AHRI 880.
- Minimum operating pressure is the minimum static pressure required to operate the terminal item assembly at maximum primary flow with a wide open damper.
- NC values are derived from sound power levels obtained in accordance with ASHRAE Standard 130-2016 and AHRI Standard 880-2017, which include duct end reflection corrections.
- Terminal item assembly is ETL certified in accordance with UL1995 and CSA 22.2.236.

The Results of this program are only an aid to the designer, and are not a substitute for professional design services.
 Price Industries accepts no liability for the adequacy of any resulting design or installation. All data subject to change without notice.

PRICE ALL-IN-ONE

Terminal Unit Selection - SDV

Project: AMN Healthcare Project Location: Dallas, TX
 Tag: 6-11 Quantity: 1

Altitude: 0 (ft)

Model: SDV

Selection

Model	Size	Primary (CFM)		Static Pressure (in. w.g.)				Electrical	
	Unit	Max	Min	Inlet SP	Downstream SP	Differential PD	Min Oper. PD	MCA	MOP
SDV	12	1100	220	1.00	0.25	0.75	0.01	N/A	N/A

Sound Performance

Max Radiated Sound Power Levels (dB)							Max Radiated NC	Max Discharge Sound Power Levels (dB)							Max Discharge NC
Octave Band								Octave Band							
2	3	4	5	6	7	2		3	4	5	6	7			
54	46	43	36	34	27	--	67	61	56	54	50	49	--		

Accessories

Terminal Liner : FF50

Accessory 2 : CLH

Accessory 6 : DSW

Performance Notes:

- Dashes (--) indicate NC values less than 20.
- NC values are calculated based on procedures outlined in AHRI Standard 885-2008, "A Procedure for Estimating Occupied Space Sound Levels in the Application of Air Terminals and Air Outlets."
- Sound power levels are given in decibels (dB).
- Dashes (--) indicate sound power levels below 36-29-26-22-19-17 for each octave band; values below these sound power levels are considered below significance per AHRI 880.
- Minimum operating pressure is the minimum static pressure required to operate the terminal item assembly at maximum primary flow with a wide open damper.
- NC values are derived from sound power levels obtained in accordance with ASHRAE Standard 130-2016 and AHRI Standard 880-2017, which include duct end reflection corrections.
- Terminal item assembly is ETL certified in accordance with UL1995 and CSA 22.2.236.

The Results of this program are only an aid to the designer, and are not a substitute for professional design services.
 Price Industries accepts no liability for the adequacy of any resulting design or installation. All data subject to change without notice.

PRICE ALL-IN-ONE

Terminal Unit Selection - SDV

Project: AMN Healthcare Project
Tag: 6-12

Location: Dallas, TX
Quantity: 1

Altitude: 0 (ft)

Model: SDV

Selection

Model	Size	Primary (CFM)		Static Pressure (in. w.g.)				Electrical	
	Unit	Max	Min	Inlet SP	Downstream SP	Differential PD	Min Oper. PD	MCA	MOP
SDV	6	180	36	1.00	0.25	0.75	0.03	N/A	N/A

Sound Performance

Max Radiated Sound Power Levels (dB)							Max Radiated NC	Max Discharge Sound Power Levels (dB)							Max Discharge NC
Octave Band								Octave Band							
2	3	4	5	6	7	2		3	4	5	6	7			
51	43	35	29	27	22	--	67	61	52	48	42	42	24 (2)		

Accessories

Terminal Liner : FF50

Accessory 2 : CLH

Accessory 6 : DSW

Performance Notes:

- Dashes (--) indicate NC values less than 20.
- NC values are calculated based on procedures outlined in AHRI Standard 885-2008, "A Procedure for Estimating Occupied Space Sound Levels in the Application of Air Terminals and Air Outlets."
- Sound power levels are given in decibels (dB).
- Dashes (--) indicate sound power levels below 36-29-26-22-19-17 for each octave band; values below these sound power levels are considered below significance per AHRI 880.
- Minimum operating pressure is the minimum static pressure required to operate the terminal item assembly at maximum primary flow with a wide open damper.
- NC values are derived from sound power levels obtained in accordance with ASHRAE Standard 130-2016 and AHRI Standard 880-2017, which include duct end reflection corrections.
- Terminal item assembly is ETL certified in accordance with UL1995 and CSA 22.2.236.

The Results of this program are only an aid to the designer, and are not a substitute for professional design services.
Price Industries accepts no liability for the adequacy of any resulting design or installation. All data subject to change without notice.

PRICE ALL-IN-ONE

Terminal Unit Selection - SDV

Project: AMN Healthcare Project Location: Dallas, TX
 Tag: 6-13 Quantity: 1

Altitude: 0 (ft)

Model: SDV

Selection

Model	Size	Primary (CFM)		Static Pressure (in. w.g.)				Electrical	
	Unit	Max	Min	Inlet SP	Downstream SP	Differential PD	Min Oper. PD	MCA	MOP
SDV	6	130	26	1.00	0.25	0.75	0.02	N/A	N/A

Sound Performance

Max Radiated Sound Power Levels (dB)						Max Radiated NC	Max Discharge Sound Power Levels (dB)						Max Discharge NC
Octave Band							Octave Band						
2	3	4	5	6	7		2	3	4	5	6	7	
47	39	31	25	25	21	--	63	57	48	44	39	40	--

Accessories

Terminal Liner : FF50

Accessory 2 : CLH

Accessory 6 : DSW

Performance Notes:

- Dashes (--) indicate NC values less than 20.
- NC values are calculated based on procedures outlined in AHRI Standard 885-2008, "A Procedure for Estimating Occupied Space Sound Levels in the Application of Air Terminals and Air Outlets."
- Sound power levels are given in decibels (dB).
- Dashes (--) indicate sound power levels below 36-29-26-22-19-17 for each octave band; values below these sound power levels are considered below significance per AHRI 880.
- Minimum operating pressure is the minimum static pressure required to operate the terminal item assembly at maximum primary flow with a wide open damper.
- NC values are derived from sound power levels obtained in accordance with ASHRAE Standard 130-2016 and AHRI Standard 880-2017, which include duct end reflection corrections.
- Terminal item assembly is ETL certified in accordance with UL1995 and CSA 22.2.236.

The Results of this program are only an aid to the designer, and are not a substitute for professional design services.
 Price Industries accepts no liability for the adequacy of any resulting design or installation. All data subject to change without notice.

PRICE ALL-IN-ONE

Terminal Unit Selection - SDV

Project: AMN Healthcare Project **Location:** Dallas, TX
Tag: 6-14 ADD **Quantity:** 1

Altitude: 0 (ft)

Model: SDV

Selection

Model	Size	Primary (CFM)		Static Pressure (in. w.g.)				Electrical	
	Unit	Max	Min	Inlet SP	Downstream SP	Differential PD	Min Oper. PD	MCA	MOP
SDV	10	700	140	1.00	0.25	0.75	0.01	N/A	N/A

Sound Performance

Max Radiated Sound Power Levels (dB)							Max Radiated NC	Max Discharge Sound Power Levels (dB)							Max Discharge NC
Octave Band								Octave Band							
2	3	4	5	6	7	2		3	4	5	6	7			
54	46	40	34	31	27	--	68	61	53	51	46	46	21 (2)		

Accessories

Terminal Liner : FF50

Accessory 2 : CLH

Accessory 6 : DSW

Performance Notes:

- Dashes (--) indicate NC values less than 20.
- NC values are calculated based on procedures outlined in AHRI Standard 885-2008, "A Procedure for Estimating Occupied Space Sound Levels in the Application of Air Terminals and Air Outlets."
- Sound power levels are given in decibels (dB).
- Dashes (--) indicate sound power levels below 36-29-26-22-19-17 for each octave band; values below these sound power levels are considered below significance per AHRI 880.
- Minimum operating pressure is the minimum static pressure required to operate the terminal item assembly at maximum primary flow with a wide open damper.
- NC values are derived from sound power levels obtained in accordance with ASHRAE Standard 130-2016 and AHRI Standard 880-2017, which include duct end reflection corrections.
- Terminal item assembly is ETL certified in accordance with UL1995 and CSA 22.2.236.

The Results of this program are only an aid to the designer, and are not a substitute for professional design services.
 Price Industries accepts no liability for the adequacy of any resulting design or installation. All data subject to change without notice.