



---

# SUBMITTAL DATA

**Order #:**

**Date:** 03/10/2025

**Project:** BCF 406 Salem OR

**Project #:**

**Submitter:** Billy Prater  
UPG National Accounts-York  
5005 York Dr.,  
Norman, Oklahoma 73069  
405 419 6498

**Date**

03/10/2025

**Project Name**

BCF 406 Salem OR

**Project Number****Client / Purchaser**

## Submittal Summary Page

Qty	Tag #	Model # / Material #	Description
2	RTU 1, 2	KV20E1CR4U1CAP81F1	20 Ton, York SunChoice Single Packaged R-454B Air Conditioner, Two Stage Compressor Operation, Standard Efficiency, Bottom Duct, Electric Heat, Low Heat 25 kW, 460-3-60, 5 HP Medium Static Belt Drive Blower <ul style="list-style-type: none"> <li>• VFD with Bypass and Intellispeed</li> <li>• Dual Enthalpy Economizer w/Barometric Relief and Power Exhaust with Economizer Fault Detection &amp; Diagnostic (Meets ASHRAE 90.1-2013, IECC 2015, California Title 24, AMCA 511)</li> <li>• 2" Throwaway Filter</li> <li>• Smart Equipment Controller including Discharge Air, Return Air, and Outdoor Air Temperature Sensors. BACNet MS/TP, Modbus and N2 Communication Card.</li> <li>• Powered Convenience Outlet (110 VAC / 15 Amp)</li> <li>• HACR Circuit Disconnect</li> <li>• Microchannel condenser coils</li> <li>• Copper tube/Aluminum fin evaporator coils</li> <li>• Refrigerant Detection System</li> <li>• Hinged Access Panel</li> <li>• Polyester SMC Drain Pan</li> <li>• Condensate Overflow(COF)</li> </ul>
2	RTU 1, 2	1BD0411	Burglar Bars
1	RTU 4	KYE06A4B1AB5G323A1	5 Ton, York Sun Core Single Packaged R-454B Air Conditioner, Single Stage Cooling, 14.5 SEER2 / 12.0 EER2, 460-3-60 <ul style="list-style-type: none"> <li>• Refrigerant Detection System</li> <li>• Dry Bulb Economizer Enhanced Static (Downflow only) (with Barometric Relief) with Economizer Fault Detection &amp; Diagnostic (Meets ASHRAE 90.1-2013, IECC 2015, California Title 24, AMCA 511)</li> <li>• Medium Static Belt Drive Blower</li> <li>• Smart Equipment Controller including Discharge Air, Return Air, and Outdoor Air Temperature Sensors. BACNet MS/TP, Modbus and N2 Communication Card.</li> <li>• Powered Convenience Outlet</li> <li>• Non-fused Disconnect (60 Amp)</li> <li>• Microchannel All Aluminum Condenser Coil, Copper tube/Aluminum fin Evaporator Coil</li> <li>• Hinged Cabinet Doors</li> </ul>
1	RTU 4	1BD0409	Burglar Bars (Small Footprint)
1	RTU 4	2EC0401	Kit, Single Enthalpy Field Installed
1	RTU 4	2EK04511446	14 kW 460-3 Electric Heat

Qty	Tag #	Model # / Material #	Description
1	RTU 5	KJ150E54U4DFACA1A1	<p>12.5 Ton, Single Packaged R-454B Air Conditioner, High Efficiency, Two Stage Cooling, 12.1 EER, 54 kW Factory Installed Electric Heat, 460-3-60</p> <ul style="list-style-type: none"> <li>• Refrigerant Detection System</li> <li>• Dry Bulb Low Leak Economizer w/Barometric Relief and Power Exhaust and Hoods (Bottom or Horizontal End Return Only) with Economizer Fault Detection &amp; Diagnostic (Meets ASHRAE 90.1-2013, IECC 2015, California Title 24, AMCA 511).</li> <li>• 5 HP High Static Belt Drive Blower</li> <li>• Standard 2" Throwaway Filters</li> <li>• IntelliSpeed control of the VFD and Manual Bypass based on stages of cooling (Provides Single Zone VAV Fan Operation as defined by ASHRAE 90.1 section 6.4.3.10)</li> <li>• Smart Equipment Controller including Discharge Air, Return Air, and Outdoor Air Temperature Sensors. BACNet MS/TP, Modbus and N2 Communication Card.</li> <li>• Powered Convenience Outlet (110 VAC / 15 Amp)</li> <li>• HACR Circuit Breaker/Disconnect</li> <li>• Micro-Channel "all-aluminum" condenser coil, Copper tube/aluminum fin evaporator coil</li> <li>• Composite Drain Pan - Front Connection</li> <li>• Tool-free maintenance with features like hinged doors for all-access panels, slide-out blower and blower motor tray</li> </ul>
1	RTU 5	2EC0401	Kit, Single Enthalpy Field Installed
1	RTU 5	1BD0408	Burglar Bars
4		S1-NSB8BHN041-0	Wall Temperature and 3% Relative Humidity Combined Sensor, No Display, WHITE, NO JCI LOGO, NS8000 Series
2		S1-AG3180E	SENSOR,CONDS OVERFLOW,PLNM RATED,W/

Equipment start-up and commissioning by a factory trained technician is recommended.  
Contact your supplying distributor or sales representative for additional information & guidance.



WARNING: Cancer and Reproductive Harm - [www.P65Warnings.ca.gov](http://www.P65Warnings.ca.gov)

Project Name: **BCF 406 Salem OR**

 Unit Model #: **KV20E1CR4U1CAP81F1**

 Quantity: **2** Tag #: **RTU 1, 2**

 System: **KV20E1CR4U1CAP81F1**

### Cooling Performance

Total gross capacity	240.4 MBH
Sensible gross capacity	165.3 MBH
Total net capacity	227.1 MBH
Sensible net capacity	152.0 MBH
Efficiency (at ARI)	11.00 EER
Integrated eff. (at ARI)	14.20 IEER
Ambient DB temp.	105.0 °F
Entering DB temp.	80.0 °F
Entering WB temp.	67.0 °F
Evap Coil Leaving DB temp.	60.9 °F
Evap Coil Leaving WB temp.	57.5 °F
Unit Leaving DB temp.	62.4 °F
Unit Leaving WB temp.	58.2 °F
Leaving air temp dew point	55.30 °F
Sound power	82 dB(a)

### Refrigerant

Refrigerant type	R-454B
Sys1	10 lb
Sys2	10 lb 12 oz

### Heating Performance

Entering DB temp.	60 °F
Heating output capacity (Max)	78.4 MBH
Nominal electric heat	25 kW
Applied electric heat	23.0 kW
Installed	Factory
Supply air	8000 cfm
Leaving DB temp.	69.1 °F
Air temp. rise	9.1 °F

### Supply Air Blower Performance

Supply air	8000 cfm
Ext. static pressure	1.0 IWG
Addl. Unit Losses (Options/Accessories)	-0.14 IWG
Blower speed	955 rpm
Max BHP of Motor (including service factor)	5.75 HP
Duct location	Bottom
Motor rating	5.00 HP
Actual required BHP	4.19 HP
Power input	3.91 kW
Elevation	0 ft
Drive type	BELT

### Exhaust Air Blower Performance

Supply Air	4093 cfm
Ext. static pressure	0.10 IWG
Blower speed	1044 rpm
Speed tap	Hi
Motor rating	1.5 HP
Power input	1.70 kW
Drive type	DIRECT
Unit static resistance	-0.14 IWG
Duct location	Bottom

### Outside/Mixed Air

Outside Air cfm	2080 cfm
-----------------	----------

### Electrical Data

Power supply	460-3-60
Unit min circuit ampacity	63.1 A
Unit max over-current protection	80 A

### Dimensions & Weight

Hgt	49 in	Len	144 in	Wth	89 in
Weight with factory installed options	2250 lb				

### Clearances

Right	42 in	Front	80 in	Rear	36 in
Top	120 in	Bottom	0 in	Left	96 in

Note: Please refer to the tech guide for listed maximum static pressures



### 20 Ton

- Manufactured at an ISO 9001 Registered Facility and Each Rooftop is Completely Computer-Run Tested Prior to Shipment.

### Unit Features

- Refrigerant Detection System (RDS) is Factory Installed
- Two Stage Compressor Operation
- Two independent refrigerant circuits
- Full Perimeter Base Rails with Built in Rigging Capabilities
- Dual Enthalpy Economizer w/Barometric Relief and Power Exhaust with Economizer Fault Detection & Diagnostic (Meets ASHRAE 90.1-2013, IECC 2015, California Title 24, AMCA 511)
- 5 HP Medium Static Belt Drive Blower
- 2" Throwaway Filter
- Replacement Filters: 6 (20" x 25" x 2" or 4"). Unit accepts 2" or 4" wide filters.
- Units are provided with the selected 2-inch or 4-inch filter and can easily be converted in the field to accept either size in the standard filter rack
- Utility Connections - Gas and electrical utility locations are supplied in the unit underside as well as the side of the unit. Utility connections can be made quickly and with a minimum amount of field labor
- Copper tube/Aluminum fin evaporator coils
- Microchannel condenser coils

### BAS Controller

- Smart Equipment Controller including Discharge Air, Return Air, and Outdoor Air Temperature Sensors. BACNet MS/TP, Modbus and N2 Communication Card.

### Standard Unit Controller: Smart Equipment Control Board

- An Integrated Low-Ambient Control, Anti-Short Cycle Protection, Lead-Lag, Fan On and Fan off Delays, Low Voltage Protection, On-Board Diagnostic and Fault Code Display. Allows all units to operate in the cooling mode down to 0 °F outdoor ambient without additional components or intervention.
- Safety Monitoring - Monitors the High and Low-Pressure Switches, the Freezestats, the Gas Valve, if Applicable, and the Temperature Limit Switch on Gas and Electric Heat Units. The Unit Control Board will Alarm on Ignition Failures, Safety Lockouts and Repeated Limit Switch Trips.

### Warranty

- One (1) Year Limited Warranty on the Complete Unit
- Five (5) Year Warranty - Compressors and Electric Heater Elements





Project Name: **BCF 406 Salem OR**

Unit Model #: **KV20E1CR4U1CAP81F1**

Quantity: **2** Tag #: **RTU 1, 2**

System: **KV20E1CR4U1CAP81F1**

**Additional Electrical Data**

Power supply	460-3-60
Unit min circuit ampacity	63.1 A
Unit max over-current protection	80 A
Min Voltage	416 V
Max Voltage	508 V
Comp #1 RLA	16
Comp #1 LRA	142
Comp #2 RLA	18.6
Comp #2 LRA	142
Indoor Mtr Voltage	460-3-60
Indoor Mtr FLA	9.9
Outdoor Mtr Qty	4
Outdoor Fan Voltage	460-1-60
OD Fan Mtr FLA (ea.)	1.3
Power Ex Mtr Qty (if applicable)	2
Powered Ex Voltage(if applicable)	460-1-60
Power Ex Mtr FLA (ea) (if applicable)	2.2

Project Name: **BCF 406 Salem OR**

Unit Model #: **KV20E1CR4U1CAP81F1**

Quantity: **2** Tag #: **RTU 1, 2**

System: **KV20E1CR4U1CAP81F1**

**JOBSITE INPUTS**

**RDS SUMMARY (Lowest Elevation Floor Being Served)**

**Refrigerant Detection System (RDS) Not Required.**

Room with the Lowest Discharge Height	0	ft
Smallest RDS Required Room Area on the Lowest Floor	N/A	ft <sup>2</sup>
Min. Allowed Smallest Room Area without an RDS	N/A	ft <sup>2</sup>
Total Applied Area	0	ft <sup>2</sup>
Min. Allowed Total Applied Area	N/A	ft <sup>2</sup>
Min. CFM when RDS is enabled	N/A	cfm
Min. System Exhaust (External to Unit)	N/A	cfm
Total Largest Circuit Refrigerant Charge	0	lb



R454B is a mildly flammable refrigerant. Unit installation must be in compliance with UL 60335-2-40 and installation and operations manual available on Solution Navigator, DS Solutions app and shipped with the unit.

Project Name: **BCF 406 Salem OR**

Unit Model #: **KV20E1CR4U1CAP81F1**

Quantity: **2** Tag #: **RTU 1, 2**

System: **KV20E1CR4U1CAP81F1**

## Factory Installed Options

### KV20E1CR4U1CAP81F1

Equipment Options	Option(s) Selected
Product Category:	<b>K</b> York SunChoice Single Packaged R-454B Air Conditioner
Efficiency:	<b>V</b> Standard Efficiency, Bottom Duct
Nominal Cooling Capacity:	<b>20</b> 20 Ton
Heat Type:	<b>E</b> Electric Heat
Heat Size:	<b>1</b> Low Heat 25 kW
Blower Option:	<b>C</b> 5 HP Medium Static Belt Drive Blower
Air Volume:	<b>R</b> Two Stage Compressor Operation VFD with Bypass and Intellispeed
Voltage:	<b>4</b> 460-3-60
Outside Air Option:	<b>U</b> Dual Enthalpy Economizer w/Barometric Relief and Power Exhaust with Economizer Fault Detection & Diagnostic (Meets ASHRAE 90.1-2013, IECC 2015, California Title 24, AMCA 511)
Coil Options:	<b>1</b> Microchannel condenser coils Copper tube/Aluminum fin evaporator coils
Controls:	<b>C</b> Smart Equipment Controller including Discharge Air, Return Air, and Outdoor Air Temperature Sensors. BACNet MS/TP, Modbus and N2 Communication Card.
Sensor Options:	<b>A</b> Refrigerant Detection System
Service Options:	<b>P</b> Powered Convenience Outlet (110 VAC / 15 Amp) HACR Circuit Disconnect
Refrigeration:	<b>8</b>
Additional Options:	<b>1</b> 2" Throwaway Filter
Cabinet Options:	<b>F</b> Hinged Access Panel Polyester SMC Drain Pan Condensate Overflow(COF)
Product Generation:	<b>1</b>

## Field Installed Accessories

- 1BD0411 - Burglar Bars (85.0 lbs)
- 1CV0407 - Concentric Diffuser, Flush Mount, 24X28
- 1CV0408 - Concentric Diffuser, Flush Mount, 24X54
- 1CV0409 - Concentric Diffuser, Flush Mount, 28X60
- 1CV0416 - Concentric Diffuser, Side Discharge, 24X48
- 1CV0417 - Concentric Diffuser, Side Discharge, 24X54
- 1CV0421 - Concentric Diffuser, Specialty, 28X28

Project Name: **BCF 406 Salem OR**

Unit Model #: **KV20E1CR4U1CAP81F1**

Quantity: **2** Tag #: **RTU 1, 2**

System: **KV20E1CR4U1CAP81F1**

- 1CV0423 - Concentric Diffuser, Specialty, 36X36
- 1CV0426 - Concentric Diffuser, Specialty, 24X24
- 1CV0427 - Concentric Diffuser, Specialty, 28X28
- 1CV0428 - Concentric Diffuser, Specialty, 30X30
- 1CV0429 - Concentric Diffuser, Specialty, 36X36
- 1HG0455 - Louvered Hail/Coil Guard (86.0 lbs)
- 1RC0444 - 14" Roof Curb (188.0 lbs)
- 1RC0447 - 24" Roof Curb (260.0 lbs)
- 2AP0402 - Air Proving Switch (1.0 lbs)
- 2AQ04700524 - CO<sup>2</sup> Space Sensor - Wall Mount Accessory (5.0 lbs)
- 2AQ04700624 - CO<sup>2</sup> Unit Mount Accessory (4.6 lbs)
- 2DF0403 - Dirty Filter Switch (1.0 lbs)
- 2LA04700646 - Low Ambient Controller for 460V (12.0 lbs)
- 2SD04702024 - Supply Air Smoke Detector (8.0 lbs)
- 2SD04703024 - Return Air Smoke Detector (8.0 lbs)
- 2SD04703124 - Supply & Return Air Smoke Detector (12.0 lbs)
- S1-03102529000 - Non-Networking Wall Sensor – Allows remote sensing and control from single or multiple zones. (0.1 lbs)
- S1-03102529004 - Non-Networking Wall Sensor with Over-ride button – Allows remote sensing and control from single or multiple zones. Override allows setpoint to be overridden for 2 hour time period. (0.2 lbs)
- S1-03103489000 - Temp sensor, 80mm x 80mm, LCD display, screw terminals, adjustable setpoint, JCI logo (0.1 lbs)
- S1-03103490000 - Temp sensor w/Economizer FDD, 120mm x 80mm, LCD display, screw terminals, adjustable setpoint, no logo (0.0 lbs)
- S1-03103517000 - Temp sensor, 120mm x 80mm, no display, no dial, screw terminals, no logo (0.4 lbs)
- S1-03103519000 - Network Sensor ,CO<sub>2</sub>, No Display (0.2 lbs)
- S1-LC-TMR100-0 - Transparent Wireless MS/TP Router, Coordinator, or Repeater. Wireless mesh network up 1,000 ft. line-of-sight (250 ft. recommended) (55.1 lbs)
- S1-LC-TMRKIT-0 - NEMA 3R panel with liquid-tight conduit for mounting TMR outdoors. TMR sold separately. (0.3 lbs)
- S1-MP-PRTKIT-0P - MAP (Multiple Access Portal) Gateway Kit- Replacement MAP gateway protective case, lanyard and communication cable. Use only to replace worn or damaged components. (0.3 lbs)
- S1-NSB8BHN041-0 - Wall Temperature and 3% Relative Humidity Combined Sensor, No Display, WHITE, NO JCI LOGO, NS8000 Series (0.4 lbs)
- S1-NSB8BHN043-0 - Wall Temperature and 3% Relative Humidity Combined Sensor, No Display, BLACK, NO JCI LOGO, NS8000 Series (0.4 lbs)
- S1-NSB8BHN141-0 - Wall Temperature and 3% Relative Humidity Combined Sensor, Warmer/Cooler Display, WHITE, NO JCI LOGO, NS8000 Series (0.4 lbs)
- S1-NSB8BHN143-0 - Wall Temperature and 3% Relative Humidity Combined Sensor, Warmer/Cooler Display, BLACK, NO JCI LOGO, NS8000 Series (0.4 lbs)
- S1-NSB8BHN240-0 - Zone Temperature Sensor. +3% RH, LCD DISPLAY, LOCAL SETPOINT CONTROL , WHITE, WITH JCI LOGO (0.4 lbs)
- S1-NSB8BHN241-0 - Zone Temperature Sensor. +3% RH, LCD DISPLAY, LOCAL SETPOINT CONTROL , WHITE, NO LOGO (0.4 lbs)
- S1-NSB8BHN243-0 - Wall Temperature and 3% Relative Humidity Combined Sensor, Full Display, BLACK, NO JCI LOGO, NS8000 Series (0.4 lbs)
- S1-NSB8BPN240-0 - Wall Temperature and 2% Relative Humidity Combined Sensor, Full Display, WHITE, JCI LOGO, NS8000 Series (0.4 lbs)
- S1-NSB8BPN241-0 - Wall Temperature and 2% Relative Humidity Combined Sensor, Full Display, WHITE, NO JCI LOGO, NS8000 Series (0.4 lbs)
- S1-NSB8BPN243-0 - Wall Temperature and 2% Relative Humidity Combined Sensor, Full Display, BLACK, NO JCI LOGO, NS8000 Series (0.4 lbs)
- S1-NSB8BTN041-0 - Zone Temperature Sensor Only, NO DISPLAY, NO SETPOINT CONTROL , WHITE, NO LOGO (0.4 lbs)
- S1-NSB8BTN141-0 - Zone Temperature Sensor Only, NO DISPLAY, WARMER/COOLER TEMP. ADJUSTMENT , WHITE, NO LOGO (0.4 lbs)
- S1-NSB8BTN143-0 - Wall Temperature Sensor, Warmer/Cooler Display, BLACK, NO JCI LOGO, NS8000 Series (0.4 lbs)
- S1-NSB8BTN240-0 - Zone Temperature Sensor Only, LCD DISPLAY, LOCAL SETPOINT CONTROL , WHITE, WITH JCI LOGO (0.4 lbs)
- S1-NSB8BTN241-0 - Zone Temperature Sensor Only, LCD DISPLAY, LOCAL SETPOINT CONTROL , WHITE, NO LOGO (0.4 lbs)
- S1-NSB8BTN243-0 - Wall Temperature Sensor, Full Display, BLACK, NO JCI LOGO, NS8000 Series (0.4 lbs)
- S1-SE-COM2001-0 - Field Installed Communication Card for Simplicity SE control. Can be field configurable for BACnet, N2 or ModBUS MSTP, R454B (1.0 lbs)
- S1-TBSU309-Y - York Branded, 2 Heating 4 Cooling stages, 7-Day Programmable, Humidity and IAQ sensors, Title 24 OpenADR compliant. (0.6 lbs)

Project Name: **BCF 406 Salem OR**Unit Model #: **KV20E1CR4U1CAP81F1**Quantity: **2** Tag #: **RTU 1, 2**System: **KV20E1CR4U1CAP81F1**

- S1-TC500A-N - Honeywell TC500A, 5 Heat 3 Cool Heat Pump, 3 Heat 4 Cool conventional utilizing Aux output , Auto/Man Changeover, Electronic 7 Day Programmable, Networkable with BACnet MS/TP, BACnet IP over Wi-Fi, Wi-Fi 802.11 b/g/n (2.0 lbs)
- S1-TEC3030-16-000 - 7 DAY PROGRAMMABLE THERMOSTAT, ZIGBEE PRO WIRELESS COMMUNICATION, RTU/HEAT PUMP WITH ECON, AND FULL COLOR, WHITE, NO LOGO (0.8 lbs)
- S1-TEC3031-14-000 - 7 DAY PROGRAMMABLE THERMOSTAT, ZIGBEE PRO WIRELESS COMMUNICATION, RTU/HEAT PUMP WITH ECON, OCC SENSOR, FULL COLOR, WHITE, JCI LOGO (0.8 lbs)
- S1-TEC3130-14-000 - 7 DAY PROGRAMMABLE THERMOSTAT, ZIGBEE PRO WIRELESS COMMUNICATION, RTU/HEAT PUMP WITH ECON, FULL COLOR, WHITE, JCI LOGO (0.8 lbs)
- S1-TEC3631-14-000 - 7 DAY PROGRAMMABLE THERMOSTAT, OPTIONAL MSTP OR N2 COMMUNICATION, RTU/HEAT PUMP WITH ECON, OCC SENSOR, FULL COLOR, WHITE, JCI LOGO (0.8 lbs)
- S1-YK-MAP1810-0P - MAP (Multiple Access Portal) Gateway- For use with SimplicitySE Control. (0.2 lbs)
- S1-YK-MAP1810-0S - Stationary MAP Gateway (Includes MAP Gateway, Field Bus Adapter, Mounting Bracket and 100 to 240 VAC Power Supply). US-compatible counties. (1.9 lbs)
- S1-ZFR-CBLEXT-1 - 10 FT Network Cable w/male RJ12 connections. Use to connect TMR to SSE 5.0 or SBH (1.0 lbs)
- YCCP200PK012LO - One Year Labor Only AC/HP PKG 20T
- YCCP200PK012PL - One Year Renewable Parts & Labor AC/HP PKG 20T
- YCCP200PK060PL - 5 Year Parts and Labor AC/HP PKG 20T
- YCCP200PK060PO - 5 Year Parts Only (No Compressor Coverage) AC/HP PKG 20T

Project Name: **BCF 406 Salem OR**

 Unit Model #: **KV20E1CR4U1CAP81F1**

 Quantity: **2** Tag #: **RTU 1, 2**

### KV 20T Submittal

- NOTES:**
- FOR OUTDOOR USE ONLY.
  - WEIGHTS SHOWN ARE FOR COOLING ONLY UNITS.
  - SERVICE (S) AND MINIMUM (M) CLEARANCE TO COMBUSTIBLE MATERIAL:
- | UNIT SIDE               | INCHES | [MM]   |
|-------------------------|--------|--------|
| RIGHT (S)               | 42     | [1067] |
| LEFT, NO ECON OR PE (S) | 18     | [457]  |
| LEFT, W/ ECON OR PE (S) | 96     | [2438] |
| FRONT/HEAT ACCESS (S)   | 80     | [2032] |
| REAR (S)                | 36     | [914]  |
| TOP (S)                 | 120    | [3048] |
| UNIT-TO-UNIT (S)        | 120    | [3048] |
| DUCT (M)                | 0      | [0]    |
| FLOOR (M)               | 0      | [0]    |
| FRONT/FLUE (M)          | 42     | [1067] |
- FOR SMALLER SERVICE AND OPERATIONAL CLEARANCES CONTACT YOUR APPLICATION ENGINEERING DEPARTMENT.
  - DOWNFLOW DUCTS DESIGNED TO BE ATTACHED TO ACCESSORY ROOF CURB ONLY.
  - MINIMUM CONDENSATION TRAP HEIGHT SHALL BE 1.5 TIMES THE LOWEST NEGATIVE STATIC.
  - DIMENSIONS IN [ ] ARE IN MILLIMETERS OR KILOGRAMS.
  - OPTIONAL COIL GAURDS, GAS HEAT, DISCONNECT SWITCH SHOWN.
  - HEAT EXCHANGER IS TYPICAL OF HIGH GAS HEAT OPTION.

TONNAGE	OPERATING WEIGHT (LBS) (BASE UNIT)	CENTER OF GRAVITY LOCATION (BASE UNIT)		4 POINT CORNER LOADS (LBS) (BASE UNIT)				6 POINT CORNER LOADS (LBS) (BASE UNIT)					
		X	Y	A	B	C	D	A	B	C	D	E	F
AV/KV20	1930 [875]	69.8 [1772.9]	49.1 [1247.1]	444 [201]	419 [190]	518 [235]	549 [249]	299 [136]	277 [126]	342 [155]	370 [168]	288 [131]	355 [161]

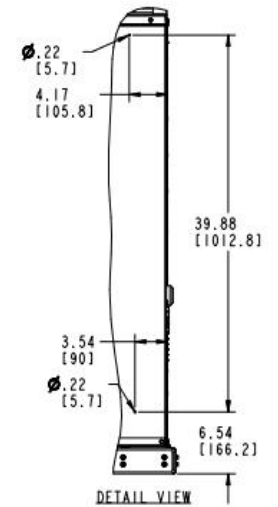
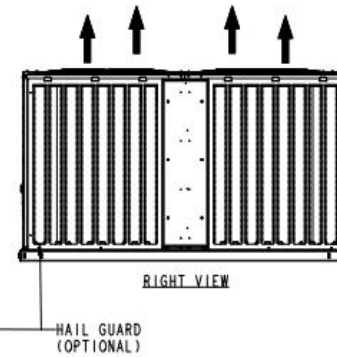
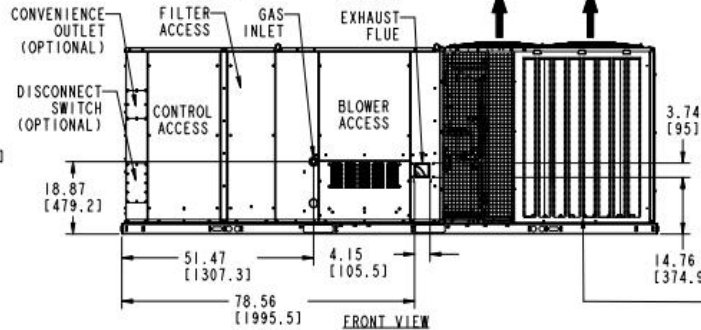
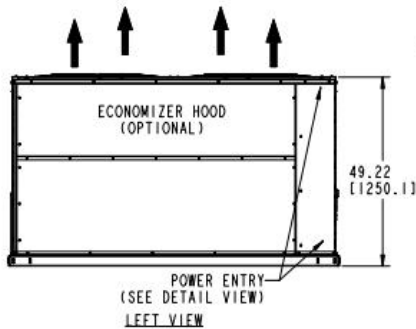
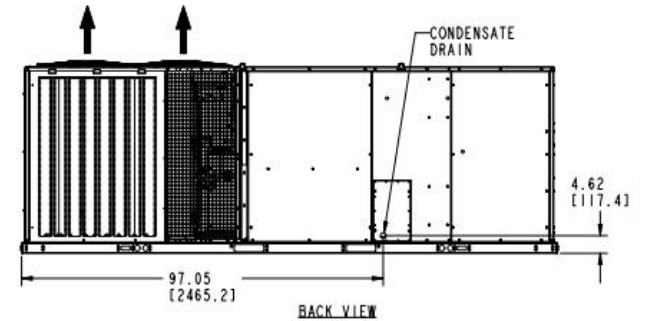
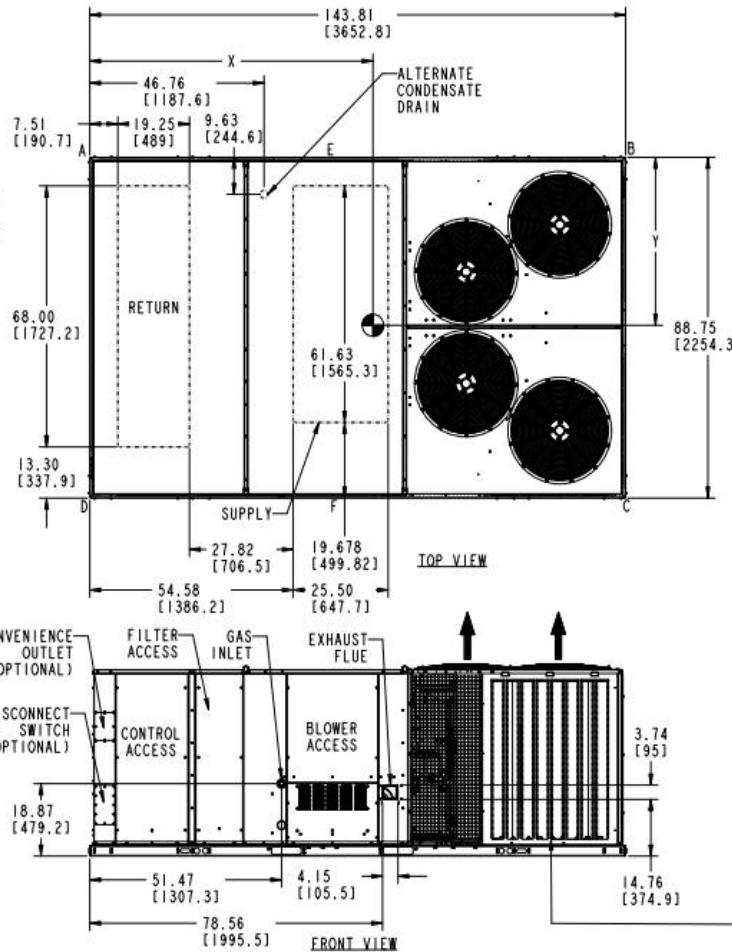
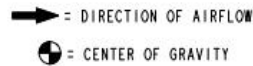

REV	DATE	REVISION RECORD	EC NO	DR	CK	ENG	THIRD ANGLE PROJECTION	ALL PROPRIETARY RIGHTS IN THE SUBJECT MATTER HEREOF ARE RESERVED AND NO PERMISSION IS GRANTED TO REPRODUCE THIS PRINT IN WHOLE OR IN PART OR DISCLOSE ANY OF THE INFORMATION HEREON TO OTHERS WITHOUT WRITTEN RELEASE BY JOHNSON CONTROLS	SAFETY AND KEY CHARACTERISTICS PER RE-POP-STD-91 MATERIAL
1	01-16-24	NEW DRAWING	XXXXX	HG	YK	AJR		DRAWING PER ASME Y14.5-2009 TOLERANCES UNLESS OTHERWISE SPECIFIED: ONE PLACE DECIMAL = ± .1 TWO PLACE DECIMAL = ± .03 THREE PLACE DECIMAL = ± .010 ANGLES = ± 2° DIMENSIONS ARE IN INCHES DO NOT SCALE PRINT	TYPE ENG SPEC SIZE
								SUBMITTAL DWG, CHOICE 4 ODF, 48.5" CAB	DWG NO. REV
								JOHNSON CONTROLS UNITARY PRODUCTS GROUP NORMAN, OK 73069	JUST-CHOICE-40DFMS PART NO. SHT NO 1 OF 1

Project Name: **BCF 406 Salem OR**

Unit Model #: **KV20E1CR4U1CAP81F1**

Quantity: 2 Tag #: RTU 1, 2

## Component Location

### Unit components

Figure 1: Component location

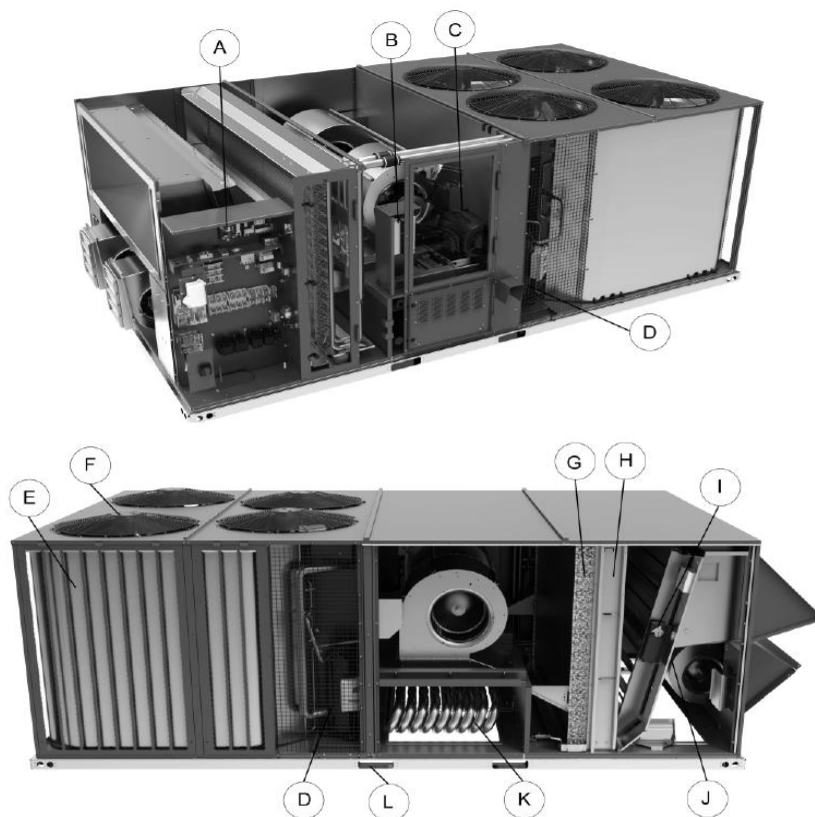

The previous figure shows the AVXX model. The following table lists the components of the unit.

Table 1: Component location table

Item	Description	Item	Description
A	Smart Equipment™ controls	G	Copper tube/aluminum fin evaporator coil
B	Optional variable frequency drive	H	Filter access, 2-inch or 4-inch filter options
C	Belt drive blower motor with dual centrifugal fan design	I	Optional economizer. Optional manual or motorized outside air dampers not shown.
D	Scroll compressors in various arrangements to produce 2 or 4 stages of cooling depending on the selected model	J	Optional powered exhaust. Optional barometric relief not shown.
E	MicroChannel condenser coils	K	Optional staged or modulating gas heat with aluminized or stainless steel heat exchanger
F	Condenser fans	L	Full perimeter base rails with holes for overhead rigging

Project Name: **BCF 406 Salem OR**

Unit Model #: **KV20E1CR4U1CAP81F1**

Quantity: **2** Tag #: **RTU 1, 2**

## Typical Installation

### Typical installation

The following figures show the typical installations for the unit.

Figure 14: Roofjack installation

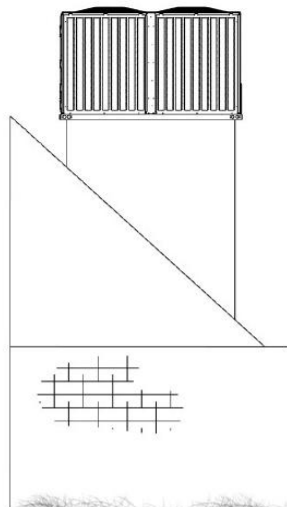
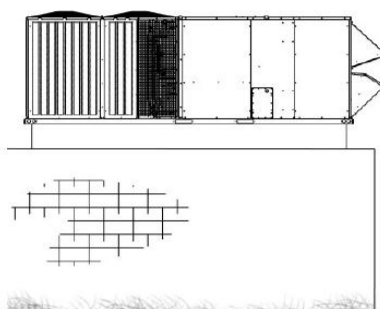

Figure 15: Roof curb installation



Project Name: BCF 406 Salem OR

Unit Model #: KV20E1CR4U1CAP81F1

Quantity: 2 Tag #: RTU 1, 2

Economizer Drawing

Economizer options

Figure 13: Economizer options

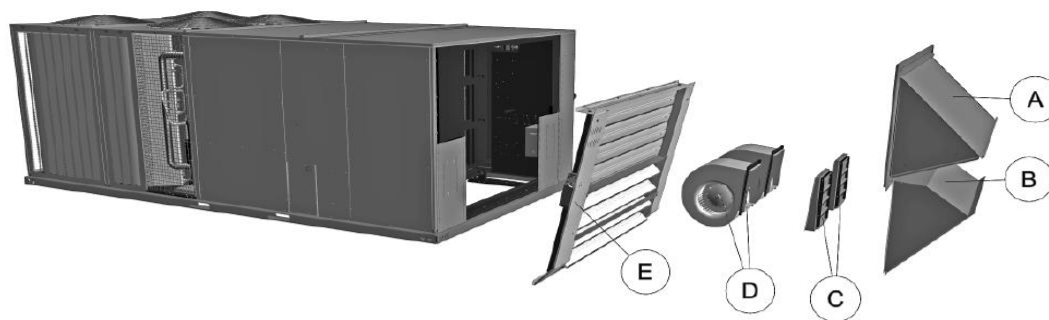

Table 38: Economizer components

Item	Description
A	Fresh air hood
B	Power exhaust hood
C	Power exhaust damper
D	Power exhaust
E	Low leak economizer

Project Name: BCF 406 Salem OR

Unit Model #: KV20E1CR4U1CAP81F1

Quantity: 2 Tag #: RTU 1, 2

Rainhood Drawing

Rain hood dimensions

Figure 8: Rain hood dimensions

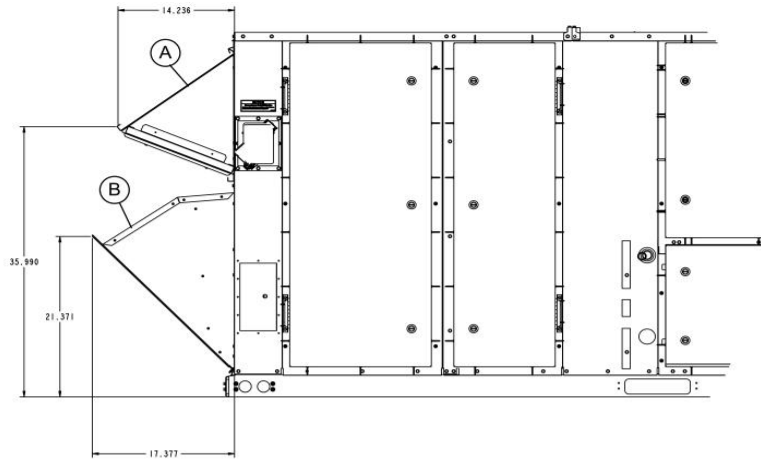

Table 32: Rain hood components

Item	Description
A	Economizer/motorized damper and power exhaust rain hood
B	Air intake hood

Project Name: **BCF 406 Salem OR**

 Unit Model #: **KYE06A4B1AB5G323A1**

 Quantity: **1 Tag #: RTU 4**

 System: **KYE06A4B1AB5G323A1**

### Cooling Performance

Total gross capacity	61.1 MBH
Sensible gross capacity	45.1 MBH
Total net capacity	57.2 MBH
Sensible net capacity	41.2 MBH
Seasonal Efficiency (at ARI)	14.50 SEER2
Efficiency (at ARI)	EER
Efficiency (at ARI)	12.00 EER2
Ambient DB temp.	99.5 °F
Entering DB temp.	80.0 °F
Entering WB temp.	67.0 °F
Evap Coil Leaving DB temp.	58.5 °F
Evap Coil Leaving WB temp.	57.2 °F
Unit Leaving DB temp.	60.4 °F
Unit Leaving WB temp.	57.9 °F
Leaving air temp dew point	56.40 °F
Power input (w/o blower)	4.27 kW
Sound power	79 dB(a)

### Refrigerant

Refrigerant type	R-454B
Sys1	6 lb 2 oz

### Heating Performance

Entering DB temp.	60 °F
Heating output capacity (Max)	47.7 MBH
Nominal electric heat	14 kW
Applied electric heat	14.0 kW
Installed	Field
Supply air	2000 cfm
Leaving DB temp.	82.7 °F
Air temp. rise	22.7 °F
Stages	1

### Supply Air Blower Performance

Supply air	2000 cfm
Ext. static pressure	1.0 IWG
Add. Unit Losses (Options/Accessories)	-0.1 IWG
Blower speed	1205 rpm
Max BHP of Motor (including service factor)	2.40 HP
Duct location	Bottom
Motor rating	2.40 HP
Actual required BHP	1.24 HP
Power input	1.16 kW
Elevation	1306 ft
Drive type	BELT

### Electrical Data

Power supply	460-3-60
Unit min circuit ampacity	28.2 A
Unit min over-current protection	30 A
Unit max over-current protection	30 A

### Dimensions & Weight

Hgt 41 in	Len 74 in	Wth 49 in
Weight with factory installed options 627 lb		

### Clearances

Right	18 in	Front	36 in	Rear	36 in
Top	72 in	Bottom	1 in	Left	12 in

Note: Please refer to the tech guide for listed maximum static pressures



### 5 Ton

- All units are manufactured at an ISO 9001 registered facility and each rooftop is completely computer-run tested prior to shipment.

### Unit Features

- Refrigerant Detection System (RDS) is Factory Installed
- Single Stage Cooling
- Unit Cabinet Constructed of Powder Painted Steel, Certified At 750 Hours Salt Spray Test (ASTM B-117 Standards)
- Either supply and/or return can be field converted from vertical to horizontal configuration without cutting panels.
- Full perimeter base rails with built in rigging capabilities
- Scroll Compressors
- Dry Bulb Economizer Enhanced Static (Downflow only) (with Barometric Relief) with Economizer Fault Detection & Diagnostic (Meets ASHRAE 90.1-2013, IECC 2015, California Title 24, AMCA 511)
- Medium Static Belt Drive Blower
- Solid Core Liquid Line Filter Driers
- Unit Ships with 2" Throwaway Filters
- Replacement Filters: 4 - (16" x 16"). Unit accepts 2" wide filters.
- Single Point Power Connection
- Short Circuit Current: 5kA RMS Symmetrical
- Non-fused Disconnect (60 Amp)
- Microchannel All Aluminum Condenser Coil, Copper tube/Aluminum fin Evaporator Coil

### Standard Unit Controller

- Smart Equipment Control Board
- On-Board Diagnostic and Fault Code display
- An Integrated Low-Ambient Control, Anti-Short Cycle Protection, Lead-Lag, Fan On and Fan off Delays, Low Voltage Protection, Allows all units to operate in the cooling mode down to 0 °F outdoor ambient without additional components or intervention.
- Safety Monitoring - Monitors the high and low-pressure switches, the freezestats, the gas valve, if applicable, and the temperature limit switch on gas and electric heat units. The unit control board will alarm on ignition failures, safety lockouts and repeated limit switch trips.

### BAS Controller

- Smart Equipment Controller including Discharge Air, Return Air, and Outdoor Air Temperature Sensors. BACNet MS/TP, Modbus and N2 communication card.

### Warranty

- One (1) Year Limited Warranty on the Complete Unit
- Five (5) Year Warranty - Compressors

Project Name: **BCF 406 Salem OR**Unit Model #: **KYE06A4B1AB5G323A1**Quantity: **1** Tag #: **RTU 4**System: **KYE06A4B1AB5G323A1****Additional Electrical Data**

Power supply	460-3-60
Unit min circuit ampacity	28.2 A
Unit max over-current protection	30 A
Min Voltage	432 V
Max Voltage	504 V
Comp #1 RLA	7.7
Comp #1 LRA	69.0
Indoor Mtr Voltage	460-3-60
Indoor Mtr FLA	3.6
Outdoor Mtr Qty	1
Outdoor Fan Voltage	460-1-60
OD Fan Mtr FLA (ea.)	1.3
Power Ex Mtr Qty (if applicable)	1
Powered Ex Voltage(if applicable)	460-3-60
Power Ex Mtr FLA (ea) (if applicable)	0.5
Powered Conv. Outlet FLA	8.6

Project Name: **BCF 406 Salem OR**Unit Model #: **KYE06A4B1AB5G323A1**Quantity: **1** Tag #: **RTU 4**System: **KYE06A4B1AB5G323A1****RDS SUMMARY (Lowest Elevation Floor Being Served)****JOBSITE INPUTS****Refrigerant Detection System (RDS) Not Required.**

Room with the Lowest Discharge Height	0	ft
Smallest RDS Required Room Area on the Lowest Floor	N/A	ft <sup>2</sup>
Min. Allowed Smallest Room Area without an RDS	N/A	ft <sup>2</sup>
Total Applied Area	0	ft <sup>2</sup>
Min. Allowed Total Applied Area	N/A	ft <sup>2</sup>
Min. CFM when RDS is enabled	N/A	cfm
Min. System Exhaust (External to Unit)	N/A	cfm
Total Largest Circuit Refrigerant Charge	0	lb



R454B is a mildly flammable refrigerant. Unit installation must be in compliance with UL 60335-2-40 and installation and operations manual available on Solution Navigator, DS Solutions app and shipped with the unit.

Project Name: BCF 406 Salem OR

Unit Model #: KYE06A4B1AB5G323A1

Quantity: 1 Tag #: RTU 4

System: KYE06A4B1AB5G323A1

**Factory Installed Options**

**KYE06A4B1AB5G323A1**

Equipment Options	Option(s) Selected
Product Category:	<b>KY</b> York Sun Core Single Packaged R-454B Air Conditioner
Heat Type:	<b>E</b>
Nominal Cooling Capacity:	<b>06</b> 5 Ton Single Stage Cooling 14.5 SEER2 / 12.0 EER2
Heat Size:	<b>A</b>
Voltage:	<b>4</b> 460-3-60
Airflow:	<b>B</b> Medium Static Belt Drive Blower
Airflow Options:	<b>1</b>
Coil Options:	<b>A</b> Microchannel All Aluminum Condenser Coil, Copper tube/Aluminum fin Evaporator Coil
Controls:	<b>B</b> Smart Equipment Controller including Discharge Air, Return Air, and Outdoor Air Temperature Sensors. BACNet MS/TP, Modbus and N2 Communication Card.
Sensor Options:	<b>5</b> Refrigerant Detection System
Economizer / Damper:	<b>G</b> Dry Bulb Economizer Enhanced Static (Downflow only) (with Barometric Relief) with Economizer Fault Detection & Diagnostic (Meets ASHRAE 90.1-2013, IECC 2015, California Title 24, AMCA 511)
Convenience Outlet:	<b>3</b> Powered Convenience Outlet
Electrical Options:	<b>2</b> Non-fused Disconnect (60 Amp)
Cabinet Options:	<b>3</b> Hinged Cabinet Doors
Special Options:	<b>A</b>
Product Generation:	<b>1</b>

**Field Installed Accessories**

- 1BD0409 - Burglar Bars (Small Footprint) (32.0 lbs)
- 1HG0420 - Hail Guard Kit (Small Footprint Tall Cabinet) (24.0 lbs)
- 1TB0403 - Small Footprint Thru The Base Electrical & Gas (1.0 lbs)
- 1CV0402 - Concentric Diffuser, Flush Mount, 18RD
- 1RC0456 - Curb Rigid 14" (356 mm) Small Footprint (145.0 lbs)
- 2AQ04700524 - CO<sup>2</sup> Space Sensor - Wall Mount Accessory (5.0 lbs)
- 1CV0411 - Concentric Diffuser, Side Discharge, 18RD (55.0 lbs)
- 1RC0458 - Curb Rigid 24" (610 mm) Small Footprint (135.0 lbs)
- 2AQ04700624 - CO<sup>2</sup> Unit Mount Accessory (4.6 lbs)
- 1CV0419 - Concentric Diffuser, Specialty, 18X18
- 1TB0401 - Small Footprint Thru The Base Electrical & Thru The Curb Gas (1.0 lbs)

Project Name: **BCF 406 Salem OR**

Unit Model #: **KYE06A4B1AB5G323A1**

Quantity: **1** Tag #: **RTU 4**

System: **KYE06A4B1AB5G323A1**

- 2EC0401 - Kit, Single Enthalpy Field Installed (1.0 lbs)
- 2EC0402 - Kit, Dual Enthalpy Field Installed (Includes two humidity sensors) (1.0 lbs)
- 2EK04510646 - 6 kW 460-3 Electric Heat (9.6 lbs)
- 2EK04511146 - 11.5 kW 460-3 Electric Heat (14.6 lbs)
- 2EK04511446 - 14 kW 460-3 Electric Heat (15.6 lbs)
- 2LA04704746 - Low Ambient for 1 system Units with 1 phase condenser fans (for 460V units) (4.0 lbs)
- 2PE04704246 - Power Exhaust Vert Flow Small Footprint 460V 3-ph (38.8 lbs)
- 2PM04700224 - Phase Monitor Kit (1.0 lbs)
- 2SD04701124 - Smoke Detector - Return (Downflow Only) (12.0 lbs)
- 2SD04701224 - Smoke Detector - Supply (12.0 lbs)
- 2SD04701324 - Smoke Detector - Supply (Horizontal/Downflow) and Return (Downflow Only) (12.0 lbs)
- S1-03102529000 - Non-Networking Wall Sensor – Allows remote sensing and control from single or multiple zones. (0.1 lbs)
- S1-03102529004 - Non-Networking Wall Sensor with Over-ride button – Allows remote sensing and control from single or multiple zones. Override allows setpoint to be overridden for 2 hour time period. (0.2 lbs)
- S1-ADDWIRE - Add-a-Wire allows 5-wire thermostats to use only 4 wires. (0.3 lbs)
- S1-CTSDTS - CTS Wired Temperature Sensor for thermostat | Duct \*Also works for LX Series (0.3 lbs)
- S1-CTSHTS - CTS Hardwired Temperature Sensor for CTS Thermostats \*Works with LX series as well (0.2 lbs)
- S1-CTSPLATE - Wall Plate for CTS Thermostats \*Also works for new platform LX series models below (0.0 lbs)
- S1-CTSWFTS - CTS Temperature Sensor with WiFi for CTS Thermostats \*Also works with LX Series (0.1 lbs)
- S1-LC-TMR100-0 - Transparent Wireless MS/TP Router, Coordinator, or Repeater. Wireless mesh network up 1,000 ft. line-of-sight (250 ft. recommended) (55.1 lbs)
- S1-LC-TMRKIT-0 - NEMA 3R panel with liquid-tight conduit for mounting TMR outdoors. TMR sold separately. (0.3 lbs)
- S1-LXLOCK - Locking Ring For LX-Series Thermostats (0.4 lbs)
- S1-LXPLATE - Wall Plate For LX-Series Thermostats (0.0 lbs)
- S1-LXWFM - For LX Series Thermostats - WiFi Communication (0.1 lbs)
- S1-MP-PRTKIT-0P - MAP (Multiple Access Portal) Gateway Kit- Replacement MAP gateway protective case, lanyard and communication cable. Use only to replace worn or damaged components. (0.3 lbs)
- S1-MP-STAFBA-0 - Field Bus Adapter (Includes RJ-12 to 4-position Terminal Block Adapter. Used for interfacing directly to MS/TP Field Bus) (1.0 lbs)
- S1-MP-STAKIT-0 - Stationary Cradle Only (Includes mounting bracket and field bus adapter) (0.1 lbs)
- S1-MP-STAKIT-0H - Stationary Cradle Kit (Includes mounting bracket, field bus adapter, and 100-240 VAC line voltage power supply) (1.0 lbs)
- S1-NSB8BHN041-0 - Wall Temperature and 3% Relative Humidity Combined Sensor, No Display, WHITE, NO JCI LOGO, NS8000 Series (0.4 lbs)
- S1-NSB8BHN043-0 - Wall Temperature and 3% Relative Humidity Combined Sensor, No Display, BLACK, NO JCI LOGO, NS8000 Series (0.4 lbs)
- S1-NSB8BHN141-0 - Wall Temperature and 3% Relative Humidity Combined Sensor, Warmer/Cooler Display, WHITE, NO JCI LOGO, NS8000 Series (0.4 lbs)
- S1-NSB8BHN143-0 - Wall Temperature and 3% Relative Humidity Combined Sensor, Warmer/Cooler Display, BLACK, NO JCI LOGO, NS8000 Series (0.4 lbs)
- S1-NSB8BHN240-0 - Zone Temperature Sensor. +3% RH, LCD DISPLAY, LOCAL SETPOINT CONTROL , WHITE, WITH JCI LOGO (0.4 lbs)
- S1-NSB8BHN241-0 - Zone Temperature Sensor. +3% RH, LCD DISPLAY, LOCAL SETPOINT CONTROL , WHITE, NO LOGO (0.4 lbs)
- S1-NSB8BHN243-0 - Wall Temperature and 3% Relative Humidity Combined Sensor, Full Display, BLACK, NO JCI LOGO, NS8000 Series (0.4 lbs)
- S1-NSB8BPN240-0 - Wall Temperature and 2% Relative Humidity Combined Sensor, Full Display, WHITE, JCI LOGO, NS8000 Series (0.4 lbs)
- S1-NSB8BPN241-0 - Wall Temperature and 2% Relative Humidity Combined Sensor, Full Display, WHITE, NO JCI LOGO, NS8000 Series (0.4 lbs)
- S1-NSB8BPN243-0 - Wall Temperature and 2% Relative Humidity Combined Sensor, Full Display, BLACK, NO JCI LOGO, NS8000 Series (0.4 lbs)
- S1-NSB8BTN041-0 - Zone Temperature Sensor Only, NO DISPLAY, NO SETPOINT CONTROL , WHITE, NO LOGO (0.4 lbs)
- S1-NSB8BTN141-0 - Zone Temperature Sensor Only, NO DISPLAY, WARMER/COOLER TEMP. ADJUSTMENT , WHITE, NO LOGO (0.4 lbs)
- S1-NSB8BTN143-0 - Wall Temperature Sensor, Warmer/Cooler Display, BLACK, NO JCI LOGO, NS8000 Series (0.4 lbs)
- S1-NSB8BTN240-0 - Zone Temperature Sensor Only, LCD DISPLAY, LOCAL SETPOINT CONTROL , WHITE, WITH JCI LOGO (0.4 lbs)

Project Name: **BCF 406 Salem OR**Unit Model #: **KYE06A4B1AB5G323A1**Quantity: **1** Tag #: **RTU 4**System: **KYE06A4B1AB5G323A1**

- S1-NSB8BTN241-0 - Zone Temperature Sensor Only, LCD DISPLAY, LOCAL SETPOINT CONTROL , WHITE, NO LOGO (0.4 lbs)
- S1-NSB8BTN243-0 - Wall Temperature Sensor, Full Display, BLACK, NO JCI LOGO, NS8000 Series (0.4 lbs)
- S1-TBPU435-Y - York Branded CTS Series | 3/4 Stage Heating | 2 Stage Cooling | (5+1+1) 7-day Programmable | WiFi On-Board (1.2 lbs)
- S1-TBPU436-Y - York Branded CTS Series | 3/4 Stage Heating | 2 Stage Cooling | (5+1+1) 7-day Programmable | WiFi and Humidity On-Board (1.2 lbs)
- S1-TBSU232-Y - York Branded LX Series | 2.3" Display | 2 Stage Heating | 2 Stage Cooling | 7-day Programmable (0.2 lbs)
- S1-TBSU304-Y - York Branded LX Series | 3" Display | 2 Stage Heating | 2 Stage Cooling | Non-Programmable | Humidity On-Board (1.0 lbs)
- S1-TBSU306-Y - York Branded LX Series | 3" Display | 3/4 Stage Heating | 2 Stage Cooling | (5+1+1) 7-day Programmable | Humidity On-Board (1.0 lbs)
- S1-TEC3630-14-000 - 7 DAY PROGRAMMABLE THERMOSTAT, OPTIONAL MSTP OR N2 COMMUNICATION, RTU/HEAT PUMP WITH ECON,FULL COLOR, WHITE, JCI Logo (1.1 lbs)
- S1-TL-CWCVT-0 - CWCVT Commissioning Tool (Connected Workflow Converter) (1.0 lbs)
- S1-YK/AN-RSO-ACI - Non-Networking Wall Sensor with Setpoint Adjustment and Over-ride Button – Allows remote sensing and control from single or multiple zones. (1.0 lbs)
- S1-YK-MAP1810-0P - MAP (Multiple Access Portal) Gateway- For use with SimplicitySE Control. (0.2 lbs)
- S1-YK-MAP1810-0S - Stationary MAP Gateway (Includes MAP Gateway, Field Bus Adapter, Mounting Bracket and 100 to 240 VAC Power Supply). US-compatible countries. (1.9 lbs)
- S1-ZFR-CBLEXT-1 - 10 FT Network Cable w/male RJ12 connections. Use to connect TMR to SSE 5.0 or SBH (1.0 lbs)
- YCCP050PK012LO - One Year Labor Only AC/HP PKG 1 to 5T
- YCCP050PK012PL - One Year Renewable Parts & Labor AC/HP PKG 1 to 5T
- YCCP050PK060PL - 5 Year Parts and Labor AC/HP PKG 1 to 5T
- YCCP050PK060PO - 5 Year Parts Only (No Compressor Coverage) AC/HP PKG 1 to 5T

Project Name: **BCF 406 Salem OR**

 Unit Model #: **KYE06A4B1AB5G323A1**

 Quantity: **1 Tag #: RTU 4**

### Submittal

**NOTES:**

1. FOR OUTDOOR USE ONLY.
2. WEIGHTS SHOWN ARE FOR COOLING ONLY UNITS.
3. RECOMMENDED MIN. CLEARANCES:  
 RIGHT SIDE: 18 [450] W/SIDE CONDENSATE DRAIN: 24 [600]  
 LEFT SIDE: 12 [300] W/PIGTAIL: 18 [450]  
 FRONT: 36 [900]  
 REAR: 18 [450] W/ECONOMIZER/POWER EXHAUST: 36 [900]  
 TOP: 72 [1800]  
 BOTTOM: 1 [25]
4. FOR SMALLER SERVICE AND OPERATIONAL CLEARANCES CONTACT YOUR APPLICATION ENGINEERING DEPARTMENT.
5. DOWNFLOW DUCTS DESIGNED TO BE ATTACHED TO ACCESSORY ROOF CURB ONLY. IF UNIT IS MOUNTED SIDE SUPPLY, IT IS RECOMMENDED THAT THE DUCTS ARE SUPPORTED BY CROSS BRACES, AS DONE ON ACCESSORY ROOF CURBS.
6. MINIMUM CONDENSATION TRAP HEIGHT SHALL BE 1.5 TIMES THE LOWEST NEGATIVE STATIC.
7. DIMENSIONS IN [ ] ARE IN MILLIMETERS OR KILOGRAMS.
8. OPTIONAL COIL GUARDS, GAS HEAT, DISCONNECT SWITCH SHOWN.
9. TOP PANEL EMBOSSEMENTS NOT SHOWN FOR DIMENSION CLARITY.
10. HEAT EXCHANGER IS TYPICAL OF HIGH GAS HEAT OPTION.

TONNAGE	UNIT	OPERATING WEIGHT (LBS) (BASE UNIT)	CENTER OF GRAVITY LOCATION (BASE UNIT)		4 POINT CORNER LOADS (LBS) (BASE UNIT)			
			X	Y	A	B	C	D
4	KL	564 [255.8]	36 [914.4]	26 [660.4]	153 [69.4]	145 [65.8]	130 [59]	137 [62.1]
5	KL	582 [264]	37 [939.8]	24 [609.6]	141 [64]	142 [64.4]	150 [68]	149 [67.6]
5	KQ	561 [254.5]	36 [914.4]	24 [609.6]	140 [63.5]	134 [60.8]	140 [63.5]	147 [66.7]
6	KXA	614 [278.5]	34.4 [874]	25.3 [643]	168 [76.2]	146 [66.2]	139 [63.0]	160 [72.6]
4	KY	564 [255.8]	36.3 [922]	24.9 [632]	144.9 [65.7]	139.9 [63.5]	137.1 [62.2]	142 [64.4]
5	KY	582 [264]	36.2 [919]	25.1 [638]	151.1 [68.6]	145.1 [65.8]	139.9 [63.5]	145.7 [66.1]

- DIRECTION OF AIRFLOW
- CENTER OF GRAVITY

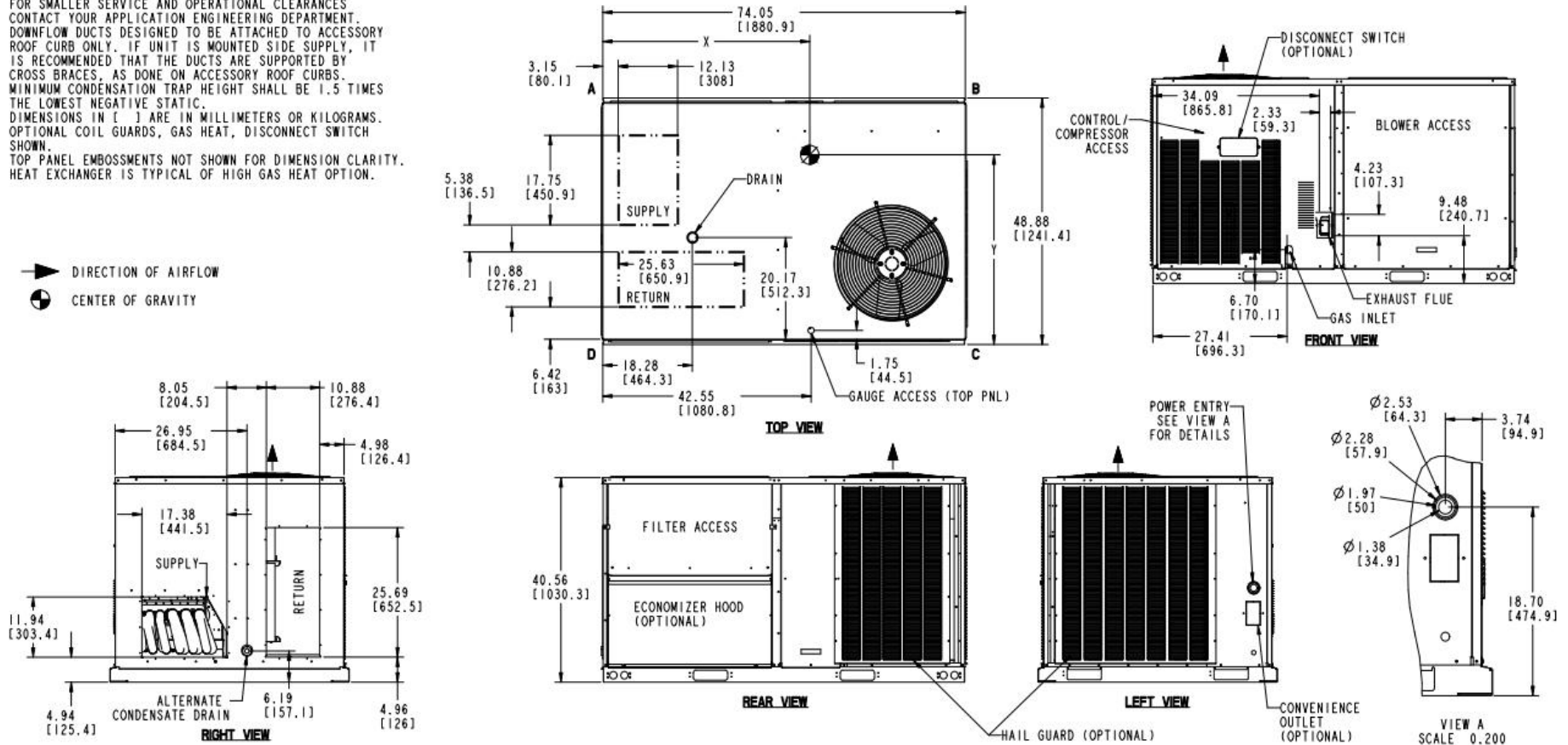

REV	DATE	REVISION RECORD	EC NO	DR	CK	ENG	THIRD ANGLE PROJECTION	ALL PROPRIETARY RIGHTS IN THE SUBJECT MATTER HEREOF ARE RESERVED AND NO PERMISSION IS GRANTED TO REPRODUCE THIS PRINT IN WHOLE OR IN PART OR DISCLOSE ANY OF THE INFORMATION HEREON TO OTHERS WITHOUT WRITTEN RELEASE BY JOHNSON CONTROLS	SAFETY AND KEY CHARACTERISTICS PER EC-POP-STD-01
A	02-20-24	NEW DRAWING (FROM 5901136)	101149	RCH	MLP	BV		DRAWING PER ASME Y14.5-2009 TOLERANCES UNLESS OTHERWISE SPECIFIED: ONE PLACE DECIMAL = ± .1 TWO PLACE DECIMAL = ± .03 THREE PLACE DECIMAL = ± .010 ANGLES = ± ° DIMENSIONS ARE IN INCHES DO NOT SCALE PRINT	TYPE NOT APPLICABLE ENG SPEC NOT APPLICABLE SIZE MATERIAL
SUBMITTAL DATA DWG, CORE I ODF, 40.5" CAB								DWG NO. 6482716	REV A
JOHNSON CONTROLS UNITARY PRODUCTS GROUP NORMAN, OK 73069								PART NO.	SHT NO 1 OF 1

Project Name: BCF 406 Salem OR

Unit Model #: KYE06A4B1AB5G323A1

Quantity: 1 Tag #: RTU 4

Field Installed Accessory Weights

Unit Accessory Weights

Unit Accessory	Weights (lbs.)
Vertical Flow Dry Bulb Economizer Small Footprint	63
Horizontal Flow Dry Bulb Economizer Small Footprint Short	96
Horizontal Flow Dry Bulb Economizer Small Footprint Short	75
Horizontal Flow Dry Bulb Economizer Small Footprint Tall	81
Horizontal Flow Dry Bulb Economizer Large Footprint Short	105
Horizontal Flow Dry Bulb Economizer Large Footprint Tall	102
Power Exhaust Vert Flow Small Footprint	38
Power Exhaust Vert Flow Large Footprint	38
Power Exhaust Horiz Flow Small Footprint	38
Power Exhaust Horiz Flow Large Footprint	38
Hail Guard Kit Small Short Factory Installed	19
Hail Guard Kit Small Tall Factory Installed	24
Hail Guard Kit Large Short Factory Installed	50
Hail Guard Kit Large Tall Factory Installed	50
Curb Rigid 14" Small Footprint	145
Curb Rigid 24" Small Footprint	135
Curb Rigid 14" Large Footprint	135
Curb Rigid 24" Large Footprint	135

Project Name: **BCF 406 Salem OR**

Unit Model #: **KJ150E54U4DFACA1A1**

Quantity: **1** Tag #: **RTU 5**

System: **KJ150E54U4DFACA1A1**

### Cooling Performance

Total gross capacity	159.1 MBH
Sensible gross capacity	110.4 MBH
Total net capacity	142.9 MBH
Sensible net capacity	94.2 MBH
Efficiency (at ARI)	12.10 EER
Integrated eff. (at ARI)	15.40 IEER
Ambient DB temp.	105.0 °F
Entering DB temp.	80.0 °F
Entering WB temp.	67.0 °F
Evap Coil Leaving DB temp.	59.6 °F
Evap Coil Leaving WB temp.	56.9 °F
Unit Leaving DB temp.	62.6 °F
Unit Leaving WB temp.	58.0 °F
Leaving air temp dew point	55.10 °F
Power input (w/o blower)	12.90 kW
Sound power	82 dB(a)

### Refrigerant

Refrigerant type	R-454B
Sys1	9 lb 6 oz
Sys2	8 lb 10 oz

### Heating Performance

Entering DB temp.	60 °F
Heating output capacity (Max)	184.1 MBH
Nominal electric heat	54 kW
Applied electric heat	54.0 kW
Installed	Factory
Supply air	5000 cfm
Leaving DB temp.	94.1 °F
Air temp. rise	34.1 °F
Stages	2

### Supply Air Blower Performance

Supply air	5000 cfm
Ext. static pressure	0.72 IWG
Addl. Unit Losses (Options/Accessories)	1.28 IWG
Blower speed	1590 rpm
Max BHP of Motor (including service factor)	5.75 HP
Duct location	Bottom
Motor rating	5.00 HP
Actual required BHP	5.10 HP
Power input	4.76 kW
Elevation	0 ft
Drive type	BELT
Requires field-supplied drive	true

### Electrical Data

Power supply	460-3-60
Unit min circuit ampacity	86.4 A
Unit max over-current protection	90 A

### Dimensions & Weight

Hgt 51 in	Len 120 in	Wth 59 in
Weight with factory installed options		1484 lb

### Clearances

Right	12 in	Front	48 in	Rear	36 in
Top	72 in	Bottom	0 in	Left	36 in

Note: Please refer to the tech guide for listed maximum static pressures



### 12.5 Ton

- York Sun Pro units are manufactured at an ISO 9001 registered facility and each rooftop is completely computer-run tested prior to shipment.

### Product Features

- All units are manufactured at an ISO 9001 registered facility and each rooftop is completely computer-run tested prior to shipment.

### Unit Features

- Refrigerant Detection System (RDS) is Factory Installed
- Two Stage Cooling
- 54 kW Factory Installed Electric Heat
- Full perimeter base rails with built in rigging capabilities
- Unit Cabinet Constructed of Powder Painted Steel, Certified At 750 Hours Salt Spray Test (ASTM B-117 Standards)
- Scroll Compressor[s]
- Dry Bulb Low Leak Economizer w/Barometric Relief and Power Exhaust and Hoods (Bottom or Horizontal End Return Only) with Economizer Fault Detection & Diagnostic (Meets ASHRAE 90.1-2013, IECC 2015, California Title 24, AMCA 511).
- Slide-Out Blower/5 HP Belt Drive Motor Assembly
- Unit Ships with 2" Throwaway Filters
- Solid Core Liquid Line Filter Driers
- Replacement Filters: 4 - (24" x 20").
- Powered Convenience Outlet (110 VAC / 15 Amp)
- HACR Circuit Breaker/Disconnect
- Single Point Power Connection
- Short Circuit Current: 5kA RMS Symmetrical
- Through-the-Curb and Through-the-Base Utility Connections
- Micro-Channel "all-aluminum" condenser coil, Copper tube/aluminum fin evaporator coil
- Composite Drain Pan - Front Connection
- Tool-free maintenance with features like hinged doors for all-access panels, slide-out blower and blower motor tray

### BAS Controller

- IntelliSpeed control of the VFD and Manual Bypass based on stages of cooling. Provides Single Zone VAV Fan Operation as defined by ASHRAE 90.1 section 6.4.3.10.

### Standard Unit Controller: Smart Equipment Control Board

- Safety Monitoring - Monitors the High and Low-Pressure Switches, the Freezestats, the Gas Valve, if Applicable, and the Temperature Limit Switch on Gas and Electric Heat Units. The Unit Control Board will Alarm on Ignition Failures, Safety Lockouts and Repeated Limit Switch Trips.

### Warranty

- One (1) Year Limited Warranty on the Complete Unit
- Five (5) Year Warranty - Compressors and Electric Heater Elements



Project Name: **BCF 406 Salem OR**

Unit Model #: **KJ150E54U4DFACA1A1**

Quantity: **1** Tag #: **RTU 5**

System: **KJ150E54U4DFACA1A1**

**Additional Electrical Data**

Power supply	460-3-60
Unit min circuit ampacity	86.4 A
Unit max over-current protection	90 A
Min Voltage	432 V
Max Voltage	504 V
Comp #1 RLA	8.8
Comp #1 LRA	74.6
Comp #2 RLA	8.8
Comp #2 LRA	74.6
Indoor Mtr Voltage	460-3-60
Indoor Mtr FLA	9.9
Outdoor Mtr Qty	4
Outdoor Fan Voltage	460-1-60
OD Fan Mtr FLA (ea.)	1.1
Power Ex Mtr Qty (if applicable)	1
Powered Ex Voltage(if applicable)	460-1-60
Power Ex Mtr FLA (ea) (if applicable)	2.2
Powered Conv. Outlet FLA	20.0

Project Name: **BCF 406 Salem OR**Unit Model #: **KJ150E54U4DFACA1A1**Quantity: **1** Tag #: **RTU 5**System: **KJ150E54U4DFACA1A1****RDS SUMMARY (Lowest Elevation Floor Being Served)****JOBSITE INPUTS****Refrigerant Detection System (RDS) Not Required.**

Room with the Lowest Discharge Height	0	ft
Smallest RDS Required Room Area on the Lowest Floor	N/A	ft <sup>2</sup>
Min. Allowed Smallest Room Area without an RDS	N/A	ft <sup>2</sup>
Total Applied Area	0	ft <sup>2</sup>
Min. Allowed Total Applied Area	N/A	ft <sup>2</sup>
Min. CFM when RDS is enabled	N/A	cfm
Min. System Exhaust (External to Unit)	N/A	cfm
Total Largest Circuit Refrigerant Charge	0	lb



R454B is a mildly flammable refrigerant. Unit installation must be in compliance with UL 60335-2-40 and installation and operations manual available on Solution Navigator, DS Solutions app and shipped with the unit.

Project Name: **BCF 406 Salem OR**

Unit Model #: **KJ150E54U4DFACA1A1**

Quantity: **1** Tag #: **RTU 5**

System: **KJ150E54U4DFACA1A1**

## Factory Installed Options

### KJ150E54U4DFACA1A1

Equipment Options		Option(s) Selected
<b>Product Category:</b>	<b>KJ</b>	Single Packaged R-454B Air Conditioner, High Efficiency 12.1 EER
<b>Nominal Cooling Capacity:</b>	<b>150</b>	12.5 Ton Two Stage Cooling
<b>Heat Type and Nominal Heat Capacity:</b>	<b>E54</b>	54 kW Factory Installed Electric Heat
<b>Blower Option:</b>	<b>U</b>	5 HP High Static Belt Drive Blower IntelliSpeed control of the VFD and Manual Bypass based on stages of cooling (Provides Single Zone VAV Fan Operation as defined by ASHRAE 90.1 section 6.4.3.10)
<b>Voltage:</b>	<b>4</b>	460-3-60
<b>Outside Air Option:</b>	<b>D</b>	Dry Bulb Low Leak Economizer w/Barometric Relief and Power Exhaust and Hoods (Bottom or Horizontal End Return Only) with Economizer Fault Detection & Diagnostic (Meets ASHRAE 90.1-2013, IECC 2015, California Title 24, AMCA 511).
<b>Service Options:</b>	<b>F</b>	Refrigerant Detection System Powered Convenience Outlet (110 VAC / 15 Amp) HACR Circuit Breaker/Disconnect
<b>Sensor Options:</b>	<b>A</b>	
<b>Controls:</b>	<b>C</b>	Smart Equipment Controller including Discharge Air, Return Air, and Outdoor Air Temperature Sensors. BACNet MS/TP, Modbus and N2 Communication Card.
<b>Refrigeration:</b>	<b>A</b>	Micro-Channel "all-aluminum" condenser coil, Copper tube/aluminum fin evaporator coil
<b>Additional Options:</b>	<b>1</b>	Standard 2" Throwaway Filters
<b>Cabinet Options:</b>	<b>A</b>	Composite Drain Pan - Front Connection Tool-free maintenance with features like hinged doors for all-access panels, slide-out blower and blower motor tray
<b>Product Generation:</b>	<b>1</b>	

### Field Installed Accessories

- 1BD0408 - Burglar Bars (32.0 lbs)
- 1CV0404 - Concentric Diffuser, Flush Mount, 18X28

- 1CV0405 - Concentric Diffuser, Flush Mount, 18X32

- 1CV0406 - Concentric Diffuser, Flush Mount, 18X36

Project Name: **BCF 406 Salem OR**

Unit Model #: **KJ150E54U4DFACA1A1**

Quantity: **1** Tag #: **RTU 5**

System: **KJ150E54U4DFACA1A1**

- 1CV0413 - Concentric Diffuser, Side Discharge, 18X28
- 1CV0414 - Concentric Diffuser, Side Discharge, 18X32
- 1CV0415 - Concentric Diffuser, Side Discharge, 18X36
- 1CV0420 - Concentric Diffuser, Specialty, 24X24
- 1CV0421 - Concentric Diffuser, Specialty, 28X28
- 1CV0426 - Concentric Diffuser, Specialty, 24X24
- 1FF0414 - 2" Only Metal Filter Frame Kit (16.0 lbs)
- 1FL0402 - Permanent 2" only Filter Kit (Includes (4) Four Filters) (2.2 lbs)
- 1HG0434 - Hail Guard Kit-Provent Style (30.0 lbs)
- 1HG0441 - Hail Guard Kit-Diamond Pattern (44.0 lbs)
- 1RC0470 - Roof Curb - 8" High, Flat, Uninsulated, Full Perimeter (Shipped Knocked Down) (135.0 lbs)
- 1RC0471 - Roof Curb - 14" High, Flat, Uninsulated, Full Perimeter (Shipped Knocked Down) (135.0 lbs)
- 1RC0472 - Roof Curb, Transition-Sunline 7.5T thru 12.5T to Pro 3.0T thru 12.5T (Shipped Assembled) (200.0 lbs)
- 1RC0476 - Roof Curb - 24" High, Flat, Uninsulated, Full Perimeter (Shipped Knocked Down) (135.0 lbs)
- 2AP0402 - Air Proving Switch (1.0 lbs)
- 2AQ04700524 - CO<sup>2</sup> Space Sensor - Wall Mount Accessory (5.0 lbs)
- 2AQ04700624 - CO<sup>2</sup> Unit Mount Accessory (4.6 lbs)
- 2EC0401 - Kit, Single Enthalpy Field Installed (1.0 lbs)
- 2EC0402 - Kit, Dual Enthalpy Field Installed (Includes two humidity sensors) (1.0 lbs)
- 2LA04702424 - Low Ambient Kit (3.2 lbs)
- 2PM04700424 - Phase Monitor Kit - Pro (5.0 lbs)
- 2SD04700824 - Smoke Detector Kit w/ Mounting Hardware for Supply Air (Horizontal/Downflow) Only (9.4 lbs)
- 2SD04700924 - Smoke Detector Kit w/ Mounting Hardware for Return Air (Downflow Only) Only (10.0 lbs)
- 2SD04701024 - Smoke Detector Kit w/ Mounting Hardware for Supply (Horizontal/Downflow) and Return Air (Downflow Only) (8.0 lbs)
- S1-02812364700 - Blower Sheave for 12.5 Ton High Static Field Installed Drive (2.9 lbs)
- S1-03102529000 - Non-Networking Wall Sensor – Allows remote sensing and control from single or multiple zones. (0.1 lbs)
- S1-03102529004 - Non-Networking Wall Sensor with Over-ride button – Allows remote sensing and control from single or multiple zones. Override allows setpoint to be overridden for 2 hour time period. (0.2 lbs)
- S1-ADDWIRE - Add-a-Wire allows 5-wire thermostats to use only 4 wires. (0.3 lbs)
- S1-CTS DTS - CTS Wired Temperature Sensor for thermostat | Duct \*Also works for LX Series (0.3 lbs)
- S1-CTS HTS - CTS Hardwired Temperature Sensor for CTS Thermostats \*Works with LX series as well (0.2 lbs)
- S1-CTS PLATE - Wall Plate for CTS Thermostats \*Also works for new platform LX series models below (0.0 lbs)
- S1-CTS WFTS - CTS Temperature Sensor with WiFi for CTS Thermostats \*Also works with LX Series (0.1 lbs)
- S1-LC-TMR100-0 - Transparent Wireless MS/TP Router, Coordinator, or Repeater. Wireless mesh network up 1,000 ft. line-of-sight (250 ft. recommended) (55.1 lbs)
- S1-LC-TMRKIT-0 - NEMA 3R panel with liquid-tight conduit for mounting TMR outdoors. TMR sold separately. (0.3 lbs)
- S1-LX LOCK - Locking Ring For LX-Series Thermostats (0.4 lbs)
- S1-LX PLATE - Wall Plate For LX-Series Thermostats (0.0 lbs)
- S1-LX WFM - For LX Series Thermostats - WiFi Communication (0.1 lbs)
- S1-NSB8BHN041-0 - Wall Temperature and 3% Relative Humidity Combined Sensor, No Display, WHITE, NO JCI LOGO, NS8000 Series (0.4 lbs)
- S1-NSB8BHN043-0 - Wall Temperature and 3% Relative Humidity Combined Sensor, No Display, BLACK, NO JCI LOGO, NS8000 Series (0.4 lbs)
- S1-NSB8BHN141-0 - Wall Temperature and 3% Relative Humidity Combined Sensor, Warmer/Cooler Display, WHITE, NO JCI LOGO, NS8000 Series (0.4 lbs)
- S1-NSB8BHN143-0 - Wall Temperature and 3% Relative Humidity Combined Sensor, Warmer/Cooler Display, BLACK, NO JCI LOGO, NS8000 Series (0.4 lbs)
- S1-NSB8BHN240-0 - Zone Temperature Sensor. +3% RH, LCD DISPLAY, LOCAL SETPOINT CONTROL , WHITE, WITH JCI LOGO (0.4 lbs)
- S1-NSB8BHN241-0 - Zone Temperature Sensor. +3% RH, LCD DISPLAY, LOCAL SETPOINT CONTROL , WHITE, NO LOGO (0.4 lbs)
- S1-NSB8BHN243-0 - Wall Temperature and 3% Relative Humidity Combined Sensor, Full Display, BLACK, NO JCI LOGO, NS8000 Series (0.4 lbs)
- S1-NSB8BPN240-0 - Wall Temperature and 2% Relative Humidity Combined Sensor, Full Display, WHITE, JCI LOGO, NS8000 Series (0.4 lbs)
- S1-NSB8BPN241-0 - Wall Temperature and 2% Relative Humidity Combined Sensor, Full Display, WHITE, NO JCI LOGO, NS8000 Series (0.4 lbs)
- S1-NSB8BPN243-0 - Wall Temperature and 2% Relative Humidity Combined Sensor, Full Display, BLACK, NO JCI LOGO, NS8000 Series (0.4 lbs)

Project Name: **BCF 406 Salem OR**

Unit Model #: **KJ150E54U4DFACA1A1**

Quantity: **1** Tag #: **RTU 5**

System: **KJ150E54U4DFACA1A1**

- S1-NSB8BTN041-0 - Zone Temperature Sensor Only, NO DISPLAY, NO SETPOINT CONTROL , WHITE, NO LOGO (0.4 lbs)
- S1-NSB8BTN141-0 - Zone Temperature Sensor Only, NO DISPLAY, WARMER/COOLER TEMP. ADJUSTMENT , WHITE, NO LOGO (0.4 lbs)
- S1-NSB8BTN143-0 - Wall Temperature Sensor, Warmer/Cooler Display, BLACK, NO JCI LOGO, NS8000 Series (0.4 lbs)
- S1-NSB8BTN240-0 - Zone Temperature Sensor Only, LCD DISPLAY, LOCAL SETPOINT CONTROL , WHITE, WITH JCI LOGO (0.4 lbs)
- S1-NSB8BTN241-0 - Zone Temperature Sensor Only, LCD DISPLAY, LOCAL SETPOINT CONTROL , WHITE, NO LOGO (0.4 lbs)
- S1-NSB8BTN243-0 - Wall Temperature Sensor, Full Display, BLACK, NO JCI LOGO, NS8000 Series (0.4 lbs)
- S1-TEC3030-16-000 - 7 DAY PROGRAMMABLE THERMOSTAT, ZIGBEE PRO WIRELESS COMMUNICATION, RTU/HEAT PUMP WITH ECON, AND FULL COLOR, WHITE, NO LOGO (0.8 lbs)
- S1-TEC3031-14-000 - 7 DAY PROGRAMMABLE THERMOSTAT, ZIGBEE PRO WIRELESS COMMUNICATION, RTU/HEAT PUMP WITH ECON, OCC SENSOR, FULL COLOR, WHITE, JCI LOGO (0.8 lbs)
- S1-TEC3130-14-000 - 7 DAY PROGRAMMABLE THERMOSTAT, ZIGBEE PRO WIRELESS COMMUNICATION, RTU/HEAT PUMP WITH ECON, FULL COLOR, WHITE, JCI LOGO (0.8 lbs)
- S1-TEC3630-14-000 - 7 DAY PROGRAMMABLE THERMOSTAT, OPTIONAL MSTP OR N2 COMMUNICATION, RTU/HEAT PUMP WITH ECON, FULL COLOR, WHITE, JCI Logo (1.1 lbs)
- S1-TEC3631-14-000 - 7 DAY PROGRAMMABLE THERMOSTAT, OPTIONAL MSTP OR N2 COMMUNICATION, RTU/HEAT PUMP WITH ECON, OCC SENSOR, FULL COLOR, WHITE, JCI LOGO (0.8 lbs)
- S1-TL-CWCVT-0 - CWCVT Commissioning Tool (Connected Workflow Converter) (1.0 lbs)
- S1-YK/AN-RSO-ACI - Non-Networking Wall Sensor with Setpoint Adjustment and Over-ride Button – Allows remote sensing and control from single or multiple zones. (1.0 lbs)
- S1-YK-MAP1810-0P - MAP (Multiple Access Portal) Gateway- For use with SimplicitySE Control. (0.2 lbs)
- S1-YK-MAP1810-0S - Stationary MAP Gateway (Includes MAP Gateway, Field Bus Adapter, Mounting Bracket and 100 to 240 VAC Power Supply). US-compatible countries. (1.9 lbs)
- S1-ZFR-CBLEXT-1 - 10 FT Network Cable w/male RJ12 connections. Use to connect TMR to SSE 5.0 or SBH (1.0 lbs)
- YCCP125PK012LO - One Year Labor Only AC/HP PKG 12.5T
- YCCP125PK012PL - One Year Renewable Parts & Labor AC/HP PKG 12.5T
- YCCP125PK060PL - 5 Year Parts and Labor AC/HP PKG 12.5T
- YCCP125PK060PO - 5 Year Parts Only (No Compressor Coverage) AC/HP PKG 12.5T

Project Name: **BCF 406 Salem OR**

 Unit Model #: **KJ150E54U4DFACA1A1**

 Quantity: **1 Tag #: RTU 5**
**Submittal**

- NOTES:
- FOR OUTDOOR USE ONLY.
  - WEIGHTS SHOWN ARE FOR COOLING ONLY UNITS.
  - MIN. CLEARANCES TO BE:
    - RIGHT SIDE: 12 [305]
    - LEFT SIDE: 36 [915]
    - FRONT: 48 [1220]
    - REAR: 36 [915]
    - TOP: 72 [1830]
    - BOTTOM: 0 [0]
  - TO REMOVE THE SLIDE-OUT DRAIN PAN, A REAR CLEARANCE OF 60 in (1525 mm) IS REQUIRED. IF SPACE IS UNAVAILABLE, THE DRAIN PAN CAN BE REMOVED THROUGH THE FRONT BY SEPARATING THE CORNER WALL.
  - FOR SMALLER SERVICE AND OPERATIONAL CLEARANCES CONTACT YOUR APPLICATION ENGINEERING DEPARTMENT.
  - DOWNFLOW DUCTS DESIGNED TO BE ATTACHED TO ACCESSORY ROOF CURB ONLY. IF UNIT IS MOUNTED SIDE SUPPLY, IT IS RECOMMENDED THAT THE DUCTS ARE SUPPORTED BY CROSS BRACES, AS DONE ON ACCESSORY ROOF CURBS.
  - SIDE DUCT FLANGES ARE 0.75" HIGH. BOTTOM DUCTS DO NOT HAVE FLANGES.
  - MINIMUM CONDENSATION TRAP HEIGHT SHALL BE 1.5 TIMES THE LOWEST NEGATIVE STATIC.
  - DIMENSIONS IN [ ] ARE IN MILLIMETERS OR KILOGRAMS.
  - OPTIONAL COIL GUARDS, POWER EXHAUST, GAS HEAT, ECONOMIZER, DISCONNECT SWITCH, CONVENIENCE OUTLET, AND BAROMETRIC RELIEF & FRESH AIR HOODS SHOWN.

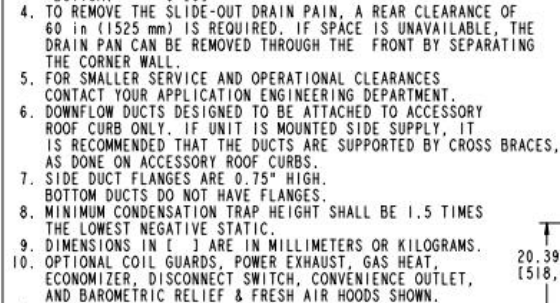

TONNAGE	UNIT	OPERATING WEIGHT (LBS) (BASE UNIT)	CENTER OF GRAVITY LOCATION (BASE UNIT)		4 POINT CORNER LOADS (LBS) (BASE UNIT)			
			X	Y	A	B	C	D
12.5	WP	1403 [636]	51 [1295,4]	25.5 [647,7]	259 [118]	347 [157]	456 [207]	340 [154]
12.5	KJ	1280 [581]	48 [1219,2]	24 [609,6]	240 [109]	281 [128]	410 [186]	350 [159]

EXCEPT WP (HEAT PUMP) UNITS.

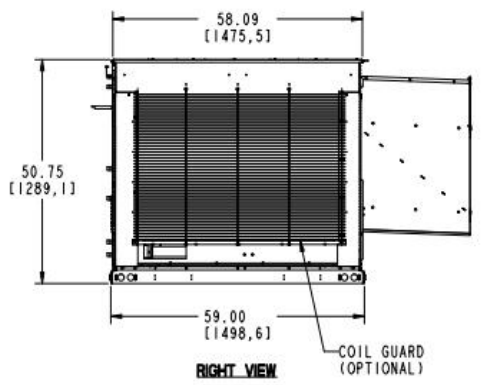
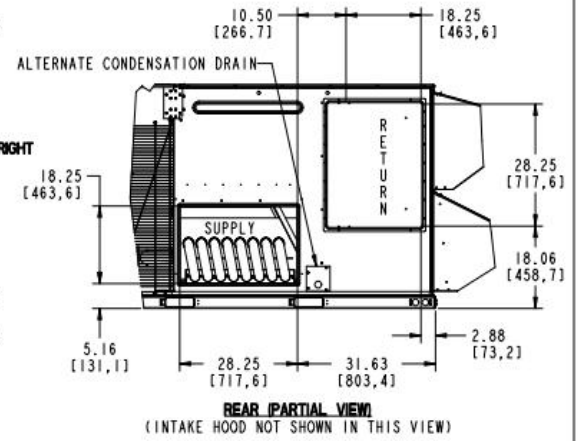
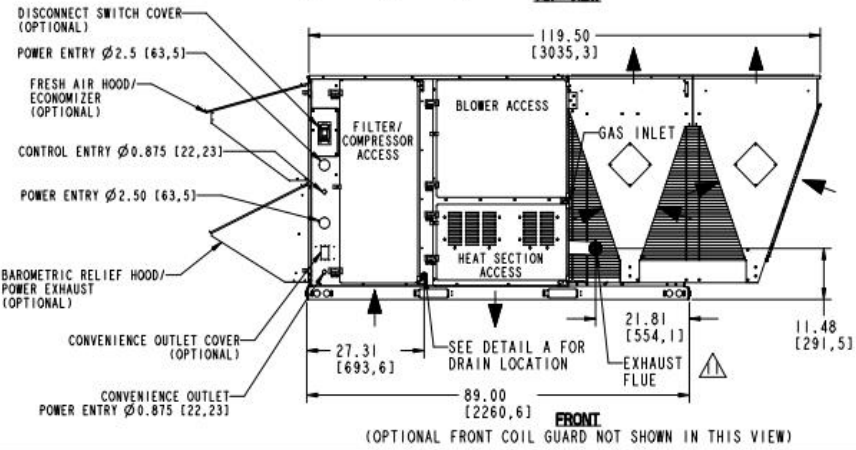
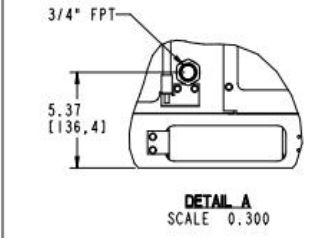
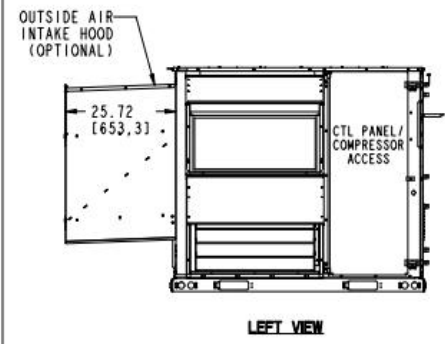
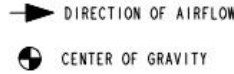

REV	DATE	REVISION RECORD	EC NO	DR	CK	ENG	THIRD ANGLE PROJECTION	ALL PROPRIETARY RIGHTS IN THE SUBJECT MATTER HEREOF ARE RESERVED AND NO PERMISSION IS GRANTED TO REPRODUCE THIS PRINT IN WHOLE OR IN PART OR DISCLOSE ANY OF THE INFORMATION HEREON TO OTHERS WITHOUT WRITTEN RELEASE BY JOHNSON CONTROLS		SAFETY AND KEY CHARACTERISTICS PER BC-PDP-37A-91		
A	10-31-23	NEW DRAWING	100724	LOP	RCH	BV		DRAWING PER ASME Y14.5-2009		MATERIAL		
							TOLERANCES UNLESS OTHERWISE SPECIFIED:		SUBMITTAL DATA DWG, PRO W COIL, 50" CAB		TYPE NOT APPLICABLE	
							ONE PLACE DECIMAL = ± .1		JOHNSON CONTROLS		DWG NO. 6454073	
							TWO PLACE DECIMAL = ± .01		UNITARY PRODUCTS GROUP		REV A	
							THREE PLACE DECIMAL = ± .010		NORMAN, OK 73069		PART NO.	
							ANGLES = ± °				SHT NO. 1 OF 1	
							DIMENSIONS ARE IN INCHES					
							DO NOT SCALE PRINT					

Project Name: **BCF 406 Salem OR**

Unit Model #: **KJ150E54U4DFACA1A1**

Quantity: **1** Tag #: **RTU 5**

## Component Locations

### Cooling With Gas Heat (6.5 Through 10 Tons)

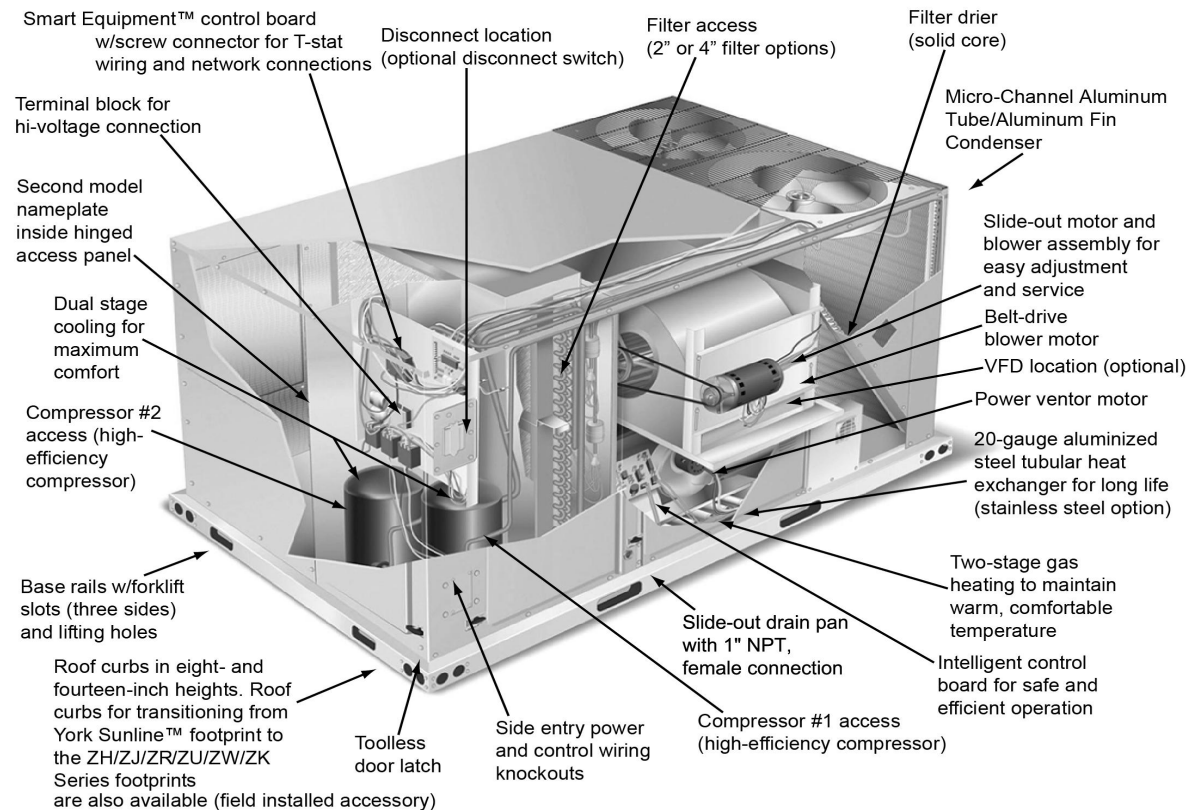

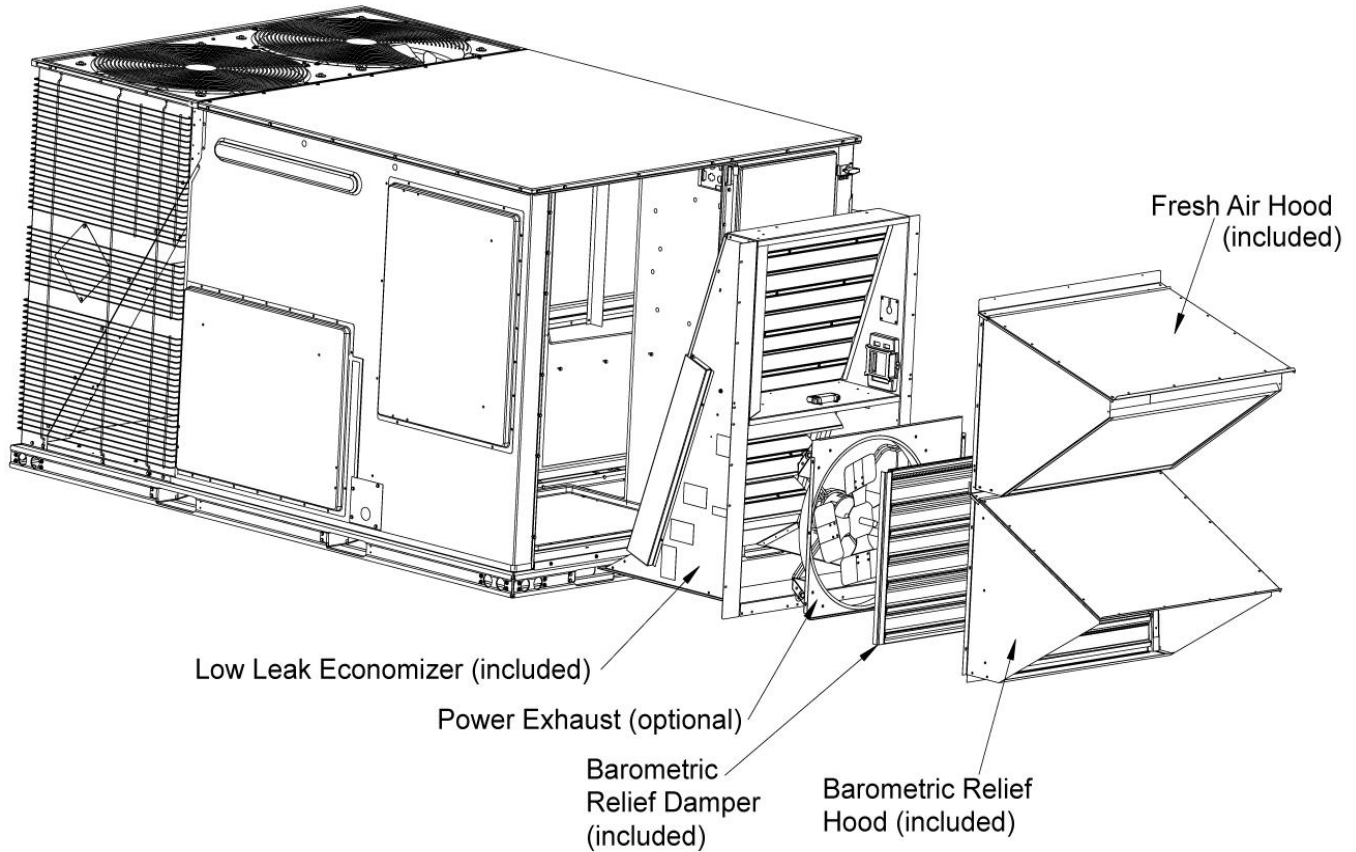
Project Name: **BCF 406 Salem OR**Unit Model #: **KJ150E54U4DFACA1A1**Quantity: **1** Tag #: **RTU 5****Low Leak Downflow Economizer****Low Leak Downflow Economizer (shown with optional Power Exhaust)**

Low leak economizers are capable achieving low leakage rates of 3 cfm/sq. ft at 1" of static pressure, meeting or exceeding the following standards:

- ASHRAE 90.1-2010
- ASHRAE 62
- AMCA 511 (licensed as Class 1A damper)
- International Energy Conservation Code (IECC)
- California Title 24

The outdoor intake opening shall be covered with a rain hood that matches the exterior of the unit. Water eliminator/filters shall be provided.

Simultaneous economizer/compressor operation is also possible. Dampers shall fully close on power loss.

Project Name: **BCF 406 Salem OR**

Unit Model #: **KJ150E54U4DFACA1A1**

Quantity: **1** Tag #: **RTU 5**

**Factory Installed Power Exhaust**

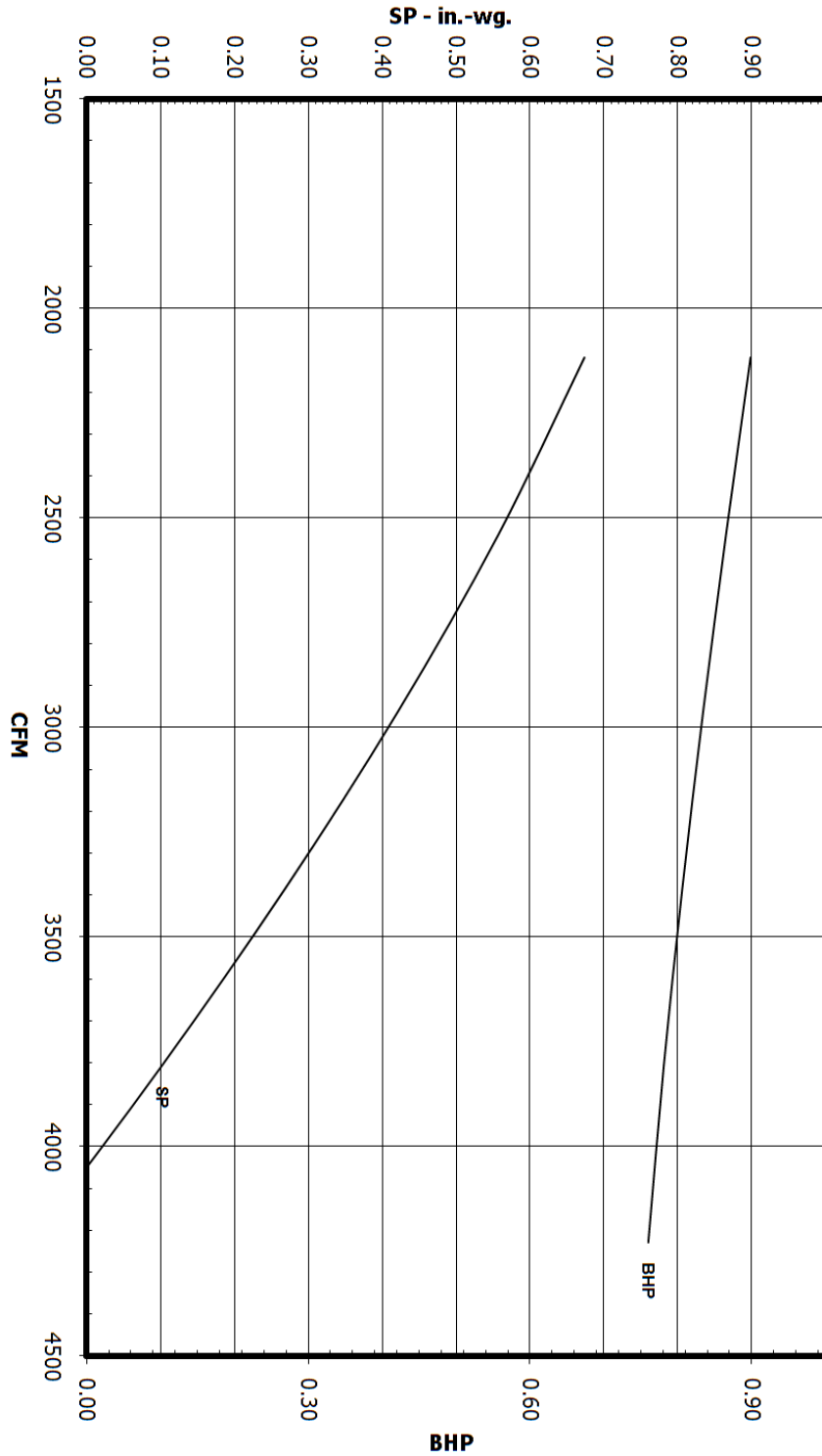

**3-12.5 Ton  
Power Exhaust  
Fan Curve**

**Date**

03/10/2025

**Project Name**

BCF 406 Salem OR

**Project Number**

**Client / Purchaser**



### Guide Specification Summary Page

Product Series	Models and Unit Tags	
15 - 27.5 Ton Sun Choice	KV20E1CR4U1CAP81F1	RTU 1, 2
3-12.5 York® Sun™ Core	KYE06A4B1AB5G323A1	RTU 4
3-12.5 York® Sun™ Pro	KJ150E54U4DFACA1A1	RTU 5

**15 to 27.5 Tons Nominal Cooling  
178,000 to 324,000 BTUH Nominal Gas Heating Output  
25 to 75 kW Electric Heating**

**23 06 80 Schedules for Decentralized HVAC Equipment**

23 06 80. 13 Decentralized Unitary HVAC Equipment Schedule

23 06 80. 13.A. Rooftop unit schedule

1. Schedule is per the project specification requirements.

**23 07 16. HVAC Equipment Insulation**

23 07 16. 13 Decentralized, Rooftop Units:

23 07 16. 13.A. Evaporator fan compartment:

1. Interior cabinet surfaces shall be insulated with a minimum 0.5 in. thick, fiber glass insulation with thermal conductivity of 0.23 or better, adhered with water based adhesive.
2. Insulation and adhesive shall meet NFPA 90A requirements for flame spread and smoke generation.

23 07 16. 13.B. Gas heat compartment:

1. Interior cabinet surfaces shall be insulated with a minimum 0.5 in. thick, fiber glass insulation with thermal conductivity of 0.23 or better, adhered with water based adhesive.
2. Insulation and adhesive shall meet NFPA 90A requirements for flame spread and smoke generation.

23 07 16. 13.C. Economizer and Control compartment:

1. Shall be Interior cabinet surfaces shall be insulated with a minimum 0.5 in. thick, fiber glass insulation with thermal conductivity of 0.23 or better, adhered with water based adhesive.
2. Insulation and adhesive shall meet NFPA 90A requirements for flame spread and smoke generation.

23 07 16. 13.D. Partition and Duct Panel:

1. Interior cabinet surfaces shall be insulated with a minimum 0.5 in. thick, fiber glass insulation with thermal conductivity of 0.23 or better, adhered with water based adhesive.
2. Insulation and adhesive shall meet NFPA 90A requirements for flame spread and smoke generation.

23 07 16. 13.E. Base Pan and Blower Back:

1. Interior cabinet surfaces shall be insulated with a minimum 0.5 in. thick, foil faced fiber glass insulation with thermal conductivity of 0.23 or better, adhered with water based adhesive.
2. Insulation and adhesive shall meet NFPA 90A requirements for flame spread and smoke generation.

**23 09 13 Instrumentation and Control Devices for HVAC**

23 09 13. 23 Sensors and Transmitters

23 09 13. 23.A. Thermostats

1. Thermostat must
  - a. Energize "Y" when calling for cooling and "W" when calling for heating.
  - b. Shall have capability to energize 2 different stages of cooling, and 2 different stages of heating.
  - c. Shall include capability for occupancy scheduling.

**23 09 23 Direct- digital Control system for HVAC**

23 09 23. 13 Decentralized, Rooftop Units:

23 09 23. 13.A. Simplicity SMART Equipment Control

1. Shall be ASHRAE 62 compliant.
2. Shall accept 20-30 VAC input power, 50/60Hz. 24 VAC nominal.
3. Shall have an operating temperature range from -40°F to 158°F; 10-90% RH (non-condensing UI), and -4°F to 158°F; 10-90% RH (non-condensing), with a storage temperature range from -40°F to 194°F; 5-95% RH (non-condensing).
4. Shall include an option of an Economizer microprocessor controller which communicates directly with the Unit Control Board and has 8 Analog outputs, 2 Analog inputs, 2 Binary outputs, 3 Binary inputs.
5. Controller shall accept the following inputs: space temperature, return air temperature sensor, set point adjustment, outdoor air temperature, indoor air quality, outdoor air quality, indoor relative humidity, compressor lock- out, fire/smoke

- shutdown, single and dual enthalpy, fan status, remote time clock, Sensor Actuator (SA) Bus communicated temperature/humidity/CO2 values from Network sensors, Field Controller (FC) Bus Network Overrides for space temperature, outdoor air temperature, space humidity, outdoor air quality, Indoor air quality, System purge.
6. Shall accept a CO2 sensor or multiple CO2 sensors networked together in the conditioned space, and be Demand Control Ventilation (DCV) ready.
  7. Shall provide compressor short-cycle protection with minimum compressor runtime set at 3 minutes standard and adjustable from 2 to 7 minutes.
  8. Unit shall provide surge protection for the controller through a circuit breaker.
  9. Shall have open communication protocols with all required points exposed. Protocols supported include: BACnet®, MS/TP, Modbus®, and N2 communication.
  10. Shall have an LCD display on the Unit Control Board to display fault messages as well as navigate the menu structure to review and change set points.
  11. Shall utilize a USB connection to allow for uploading and downloading of data.
    - a. USB shall allow for downloading of “trending data” for analysis of inputs and values on other device such as a PC.
    - b. USB shall allow for uploading of new firmware to the UCB.
    - c. USB shall allow for backing up controller set points and parameters and for uploading of these same parameters to the UCB.
  12. Shall include an RJ-12 port to be used with a Wi-Fi signal transmitting device and allow unit(s) access via any non-proprietary smart device.
    - a. Unit access shall include ability to view and change all adjustable parameters and set points using the same characteristics and values available directly through the UCB joystick and LCD display.
    - b. Unit access shall be configurable at 3 different levels to allow control over parameter and set point changes.
    - c. Wi-Fi transmitting device can be connected by 3 means.
      - 1) RJ-12 port connected directly to UCB.
      - 2) Optional connection port mounted in operating space.
      - 3) Optional connection to building network allowing unit access from any internet browser worldwide.
  13. Shall have the capability to integrate with Verasys zoning controls system.
  14. Shall not require any proprietary software or contractor tool to start-up, commission and troubleshoot unit operation.
  15. Software upgrades will be accomplished by local download via USB port on main Unit Control Board.
  16. Shall be UL Recognized, File E107041, UL 916, Energy management Equipment, UL 60335-2-40, Heating and Cooling Equipment; FCC Compliant to CFR47, Part 15, Subpart B, Class B, CSA 22.2 No. 236, Signal Equipment Industry Canada, ICES-003 Recognized, and BTL certified.

## **23 09 33 Electric and Electronic Control System for HVAC**

23 09 33. 13 Decentralized, Rooftop Units:

23 09 33. 13.A. General

1. Shall be complete with self- contained low- voltage control circuit protected by a resettable circuit breaker on the 24- v transformer side. Transformer shall have minimum 75VA capability.
2. Shall utilize color- coded wiring.
3. Shall include a central control terminal board to conveniently and safely provide connection points for vital control functions such as: smoke detectors, phase monitor, gas controller, economizer, thermostat, DDC control options, and low and high pressure switches.
4. The gas furnace shall be controlled by an integrated gas controller (IGC) microprocessor. See heat exchanger section of this specification.

23 09 33. 23.B. Safeties:

1. Compressor over- temperature and over- current.
2. Low pressure switch and high pressure switch.
  - a. Low pressure switch shall use different color wire than the high pressure switch. The purpose is to assist the installer and service technician to correctly wire and or troubleshoot the rooftop unit.
3. Automatic reset, motor thermal overload protector.
4. Gas heating section shall be provided with the following minimum protections.
  - a. Primary and auxiliary high temperature limit switches

- b. Induced draft pressure sensor
- c. Flame rollout switch
- d. Flame proving controls
- 5. Electric heat section shall be provided with the following minimum protections:
  - a. Primary, backup and auxiliary high temperature limit switches

**23 40 13 Panel Air Filters**

23 40 13 13. Decentralized, Rooftop Units:

23 40 13. 13.A. Standard filter section

- 1. Shall consist of factory installed, low velocity, disposable 2- in. thick fiberglass filters of commercially available sizes.
- 2. Units can accept 2" or 4" filters and have a field convertible transition.
- 3. Filters shall be accessible through an access panel; hinged panel with toolless access is available as described in the Special Features Options and Special Features Options and Accessories section of this specification.

**23 81 19 Self- Contained Air Conditioners**

23 81 19 13. Small- Capacity Self- Contained Air Conditioners

23 81 19. 13.A. General

- 1. Outdoor, rooftop mounted, electrically controlled, heating and cooling unit utilizing a fully hermetic, suction gas cooled, direct drive compressor(s) for cooling duty and gas combustion or nickel chromium elements for heating duty.
- 2. Factory assembled, single- piece heating and cooling rooftop unit. Contained within the unit enclosure shall be all factory wiring, piping, controls, and special features required prior to field start- up.
- 3. Unit shall be installed in accordance with the manufacturer's instructions.
- 4. Unit must be selected and installed in compliance with local, state, and federal codes.

23 81 19. 13.B. Quality Assurance

- 1. Unit meets ASHRAE 90.1 minimum efficiency requirements.
- 2. Unit shall be rated in accordance with AHRI Standards 210/240 or 340/360.
- 3. Unit shall be designed to conform to ASHRAE 15.
- 4. Unit shall be CSA tested and certified in accordance with ANSI Z21.47 -2016/CSA 2.3-2016, and CSA C22.2 No. 60335-2-40.
- 5. Insulation and adhesive shall meet NFPA 90A requirements for flame spread and smoke generation.
- 6. Unit casing shall be capable of withstanding 750- hour salt spray exposure per ASTM B117 (scribed specimen).
- 7. Roof curb shall be designed to conform to NRCA Standards.
- 8. Unit shall be subjected to a completely automated run test on the assembly line. The data for each unit will be stored at the factory, and must be available upon request.
- 9. Unit shall be designed in accordance with CSA C.22.2 NO.60335-2-40, including tested to withstand rain.
- 10. Unit shall be constructed to prevent intrusion of snow into the control box.
- 11. 15 – 25 ton units shall be shake tested to Truck 2, ASTM D4169 to ensure shipping reliability.

23 81 19. 13.C. Delivery, Storage, and Handling

- 1. Unit shall be stored and handled per manufacturer's recommendations.
- 2. Overhead crane can be used to place the units on a roof using rigging holes built into the unit base rails without any additions to the unit.
- 3. Unit shall only be stored or positioned in the upright position.

23 81 19. 13.D. Project Conditions

- 1. As specified in the contract.

23 81 19. 13.E. Operating Characteristics

- 1. Unit shall be capable of starting and running at 115°F (52°C) ambient outdoor temperature, meeting maximum load criteria of AHRI Standard 210/240 or 340/360 at ±10% voltage.
- 2. Compressor with standard controls shall be capable of operation down to 45°F (7°C), ambient outdoor temperatures. Intermittent cooling shall be operational down 0° F (-17° C). Low ambient kit is necessary if mechanically cooling at ambient temperatures below 40°F (4°C).
- 3. Unit shall be factory configured for vertical supply & return configurations.

- 23 81 19. 13.F. Electrical Requirements
1. Main power supply voltage, phase, and frequency must match those required by the manufacturer.
- 23 81 19. 13.G. Unit Cabinet
1. Unit cabinet shall be constructed of galvanized steel with exterior surfaces coated with a non-chalking, powder paint finish, certified at 750 hour salt spray test per ASTM-B117 standards.
  2. Unit cabinet exterior paint shall be: film thickness, (dry) 3.0 MILS minimum, gloss (per ASTM D523, 60°F / 16°C): 80+/- 5, Hardness: H- 2H Pencil hardness.
  3. Unit cabinet shall have gas utility entry holes in the side of the unit and in the unit underside. Entry holes shall not require field setup and shall be capped from the factory to prevent water intrusion when not in use.
  4. Unit cabinet shall have electric utility entry locations marked from the factory with a dimple for accuracy of field drilling. Entry locations shall be available for entry through the side of the unit or from the unit underside.
  5. Base Rail
    - a. Unit shall have base rails on all 4 sides.
    - b. Holes shall be provided in the base rails for rigging shackles to facilitate maneuvering and overhead rigging.
    - c. Holes shall be provided in the base rail for moving the unit by fork truck.
    - d. Base rail shall be a minimum of 15 gauge thickness.
  6. Condensate pan and connections:
    - a. Shall be a multidirectional internally sloped condensate drain pan made of a non- corrosive material.
    - b. Shall comply with ASHRAE Standard 62.
    - c. Shall use a 1" NPT female drain connection through the side of the drain pan. Connection shall be made per manufacturer's recommendations.
    - d. Shall include intentional "overflow notch" and water containment path to guide flow of water where desired in the event of a drain pan overflow.
  7. Top panel:
    - a. Shall be a multi piece top panel.
  8. Electrical Connections
    - a. All unit power wiring shall enter unit cabinet through a field drilled hole located by a factory provided dimple.
    - b. Through- the- base capability.
      - 1) Standard unit shall have a through- the- base electrical location(s) using a raised, embossed portion of the unit base-pan.
      - 2) No base-pan penetration, other than those authorized by the manufacturer, is permitted.
- 23 81 19. 13.H. Electric Heating
1. Use nickel chromium elements for heating.
  2. Shall have a single stage of capacity on 25 kW heaters and two stages of capacity for other heater capacities.
  3. Shall have a primary limit control with automatic reset to prevent the heating element system from operating at an excessive temperature.
  4. Shall have a non-resetting backup limit control to prevent the heating element system from operating at an excessive temperature in the event a primary limit control fails.
  5. Shall be wired for single point power supply with branch circuit fusing (where required).
- 23 81 19. 13.I. Coils
1. Evaporator Coils, Aluminum Fin - Copper Tube:
    - a. Standard evaporator coils shall have aluminum plate fins mechanically bonded to seamless internally grooved copper tubes with all joints brazed.
    - b. Shall be leak tested to 150 psig, pressure tested to 250 psig, and burst qualified to CSA C22.2 No. 60335-2-40.<sup>th</sup> edition burst test at 1775 psig.
    - c. Assembled unit shall be pressure tested to 450 psig.
  2. Condenser Coils, All Aluminum Microchannel:
    - a. Condenser coils shall have all aluminum microchannel design consisting of aluminum multiport flat tube design and aluminum fin. Coils shall be a furnace brazed design and contain epoxy lined shrink wrap on all aluminum to copper connections.

- b. Microchannel condenser coils shall be leak tested to 150 psig, pressure tested by supplier to 600 psig, and burst qualified to CSA C22.2 No. 60335-2-40.
  - c. Assembled unit shall be pressure tested to 450 psig.
- 23 81 19. 13.J. Refrigerant Circuits
- 1. 2 stage IntelliSpeed airflow options shall have 2 refrigerant circuits with 2 stages of cooling.
  - 2. Refrigerant circuit shall include the following control, safety, and maintenance features:
    - a. Thermostatic Expansion Valve (TXV) shall help provide optimum performance across the entire operating range.
    - b. Refrigerant filter drier - Solid core design.
    - c. Service gauge connections on suction and discharge lines.
  - 3. Compressors
    - a. Unit shall use fully hermetic scroll compressors for each independent refrigeration circuit.
    - b. Two stage models shall use a single stage compressor on each refrigeration circuit.
    - c. Compressor motors shall be cooled by refrigerant gas passing through motor windings.
    - d. Compressors shall be internally protected from high discharge temperature conditions.
    - e. Compressors shall be protected from an over- temperature and over- amperage conditions by an internal, motor overload device.
    - f. Compressor shall be factory mounted on rubber grommets.
    - g. Crankcase heaters shall be installed in the factory as needed on tandem compressor sets.
- 23 81 19. 13.K. Filter Section
- 1. Filters access is specified in the unit cabinet section of this specification.
- 23 81 19. 13.L. Evaporator Fan and Motor
- 1. Evaporator fan motor:
    - a. Shall have permanently lubricated ball-bearings.
    - b. Shall have inherent automatic- reset thermal overload protection.
    - c. The job site selected brake horsepower shall be required to not exceed the motor's nameplate horsepower rating plus the service factor.
  - 2. Evaporator Fan:
    - a. Fan shall be a belt drive assembly with an adjustable pitch motor pulley.
    - b. Blower bearings shall have an L10 life of 100,000 hrs
    - c. Shall use sealed, permanently lubricated ball-bearing type.
    - d. Shall use dual blower design consisting of two balanced blower fans on a single shaft.
    - e. Blower fan shall be double- inlet type with forward- curved blades.
    - f. Shall be constructed from steel with a corrosion resistant finish and dynamically balanced.
- 23 81 19. 13.M. Condenser Fans and Motors
- 1. Condenser fan motors:
    - a. Shall be a totally enclosed motor.
    - b. Shall use permanently lubricated ball-bearings.
    - c. Shall have inherent thermal overload protection with an automatic reset feature.
    - d. Shall use a shaft- down design.
  - 2. Condenser Fans:
    - a. Shall be a direct- driven propeller type fan.
- 23 81 19. 13.N. Special Features Options and Accessories
- 1. IntelliSpeed staged air volume system:
    - a. Evaporator fan motor:
      - 1) Shall have permanently lubricated bearings.
      - 2) Shall have a maximum continuous bhp rating for continuous duty operation; no safety factors above that rating.
      - 3) Shall be Variable Frequency duty and multi-speed control.

2. Variable Frequency Drive (VFD). Available on multi-speed (IntelliSpeed) and VAV indoor fan motor options:
  - a. Shall be installed inside the unit cabinet, mounted, wired and tested.
  - b. Shall contain Electromagnetic Interference (EMI) frequency protection.
  - c. Insulated Gate Bi- Polar Transistors (IGBT) used to produce the output pulse width modulated (PWM) waveform.
  - d. Built in LED display and controls. Does not require additional kit or options.
  - e. RS485 capability standard.
  - f. Electronic thermal overload protection.
  - g. All printed circuit boards shall be conformal coated.
3. Low Leak Economizer:
  - a. Integrated, tie-bar driven parallel modulating blade design type capable of simultaneous economizer and compressor operation.
  - b. Damper blades shall be galvanized steel with tie-bar metal linkages. Plastic or composite blades on intake or return shall not be acceptable.
  - c. Damper blades shall be class 1A dampers.
  - d. Shall include all hardware and controls to provide free cooling with outdoor air when temperature and/or humidity are below set points.
  - e. Shall be equipped with tie-bar driven dampers for both the outdoor ventilation air and the return air for positive air stream control.
  - f. Economizer shall comply with, and be certified to, the AMCA 511 standard.
  - g. Standard leak rate shall be equipped with dampers not to exceed 3 cfm/ft<sup>2</sup> leakage at 1 in. wg pressure differential.
  - h. Economizer controller shall be the Johnson Controls SE Economizer Controller
    - 1) On- board Fault Detection and Diagnostics (FDD) that senses and alerts when the economizer is not operating properly, meets the requirements for California Title 24, IECC 2015, and ASHRAE 90.1.
    - 2) Display alarms if the following occur
      - i. Economizer is economizing when conditions do not support
      - ii. Economizer is not economizing when conditions do support
      - iii. Damper Stuck
      - iv. Excess Outdoor Air
      - v. Failed Sensor
    - 3) Automatic sensor detection
    - 4) Capabilities for use with multiple-speed indoor fan systems
    - 5) Utilize digital sensors: Dry bulb and Enthalpy
    - 6) UL, CSA, and ICES-003 recognized and FCC compliant to CFR47
  - i. Shall be capable of introducing up to 100% outdoor air.
  - j. Shall be equipped with a barometric relief damper capable of relieving up to 100% return air and contain seals that meet ASHRAE 90.1 requirements. Barometric relief can be replaced by optional power exhaust.
  - k. Shall be designed to close damper(s) during loss- of- power situations with spring return built into motor.
  - l. Dry bulb outdoor air temperature sensor shall be provided as standard. Single or dual enthalpy sensing is available as a factory or field installed sensing option. Outdoor air sensor set point shall be adjustable and shall range from 40° to 80°F / 4° to 27°C. Additional sensor options shall be available as accessories.
  - m. The economizer controller shall also provide control of an accessory power exhaust unit function. Factory set at 100%, with a range of 0% to 100%.
  - n. The economizer shall maintain minimum airflow into the building during occupied period and provide design ventilation rate for full occupancy.
  - o. Dampers shall be completely closed when the unit is in the unoccupied mode.
  - p. Economizer controller shall accept a 2- 10 Vdc CO<sub>2</sub> sensor input for IAQ/DCV control. In this mode, dampers shall modulate the outdoor air damper to provide ventilation based on the sensor input.
  - q. Economizer controller shall provide indications when in free cooling mode, in the DCV mode, or the exhaust fan contact is closed.

4. Hinged and tool less access panels:
  - a. Cabinet panels shall be hinged.
  - b. Shall provide easy access with toolless latching mechanism.
  - c. Shall be on major panels of: filter, control box, fan motor, and gas or electric heat controls.
5. Unit-Mounted, Non-Fused Disconnect Switch:
  - a. Switch shall be factory installed, internally mounted.
  - b. National Electric Code (NEC) and UL approved non- fused switch shall provide unit power shutoff.
  - c. Shall be accessible from outside the unit.
  - d. Shall provide local shutdown and lockout capability.
6. Powered Convenience Outlet:
  - a. Outlet shall be powered from main line power to the rooftop unit.
  - b. Outlet shall be factory installed and internally mounted with easily accessible 115- v female receptacle.
  - c. Outlet shall include 15 amp GFI receptacles with independent fuse protection.
  - d. Voltage required to operate convenience outlet shall be provided by a factory installed step- down transformer.
  - e. Outlet shall be accessible from outside the unit.
7. Constant Volume Power Exhaust:
  - a. Power exhaust shall be used in conjunction with an integrated economizer.
  - b. Exhaust fans shall be of centrifugal blower design with dual exhaust fans.
  - c. Shall be controlled by economizer controller operation. Exhaust fans shall be energized when dampers open past the 0- 100% adjustable set point on the economizer control.
  - d. Factory installed exhaust and field installed fold out exhaust shall have built in fold out rain hood design to reduce installation time.
  - e. Bolt on field installed exhaust shall be either of same design as factory installed exhaust described above or of bolt on design, per customer selection.
8. Dual Enthalpy Sensor:
  - a. The dual enthalpy sensor option or kit shall provide 2 relative humidity sensors to be mounted in the return and outdoor air streams to provide dual enthalpy economizer control.
  - b. This kit contains all components required for dual enthalpy control and does not need to be used in conjunction with the Single Enthalpy Sensor Kit.
9. Condensate Overflow Switch:
  - a. Shall utilize float switch in condensate drain pan to signal if water level rises above acceptable threshold.
  - b. Switch shall detect a 0.25 inch rise above mounted location to determine need to send shutoff signal.
  - c. Shall send 24V signal to unit controller when tripped to shut down cooling operation and prevent additional buildup of water in condensate drain pan.

**DIVISION 23 – HEATING, VENTILATING, AND AIR-CONDITIONING(HVAC)**

**Number Title**

**23 00 00 HEATING VENTILATING, AND AIR-CONDITIONING(HVAC)**

**23 06 00 Schedules for HVAC**

**23 06 80 Schedules for Decentralized HVAC Equipment**

23 06 80. 13 Decentralized Unitary HVAC Equipment Schedule

23 06 80. 13.A Rooftop unit schedule

**23 07 00 HVAC Insulation**

**23 07 16 HVAC Equipment Insulation**

23 07 16. 13 Decentralized, Rooftop Units

23 07 16. 13.A Evaporator fan compartment

1. Interior cabinet surfaces shall be insulated with a minimum 1/2- in. thick, minimum 1 1/2 lb density, flexible fiberglass insulation coated on the air side.
2. Insulation and adhesive shall meet NFPA 90A requirements for flame spread and smoke generation.

23 07 16. 13.B Gas heat compartment

1. Aluminum foil-faced fiberglass insulation shall be used.
2. Insulation and adhesive shall meet NFPA 90A requirements for flame spread and smoke generation.

**23 09 00 Instrumentation and Control for HVAC**

**23 09 13 Instrumentation and Control Devices for HVAC**

23 09 13. 23 Sensors and Transmitters

23 09 13. 23.A Thermostats

1. Thermostat must:
  - a. energize “G” when calling for fan only or continuous fan.
  - b. have capability to energize 2 different stages of cooling, and 2 different stages of heating.
  - c. include capability for occupancy scheduling.

**23 09 23 Direct-digital Control system for HVAC**

23 09 23. 13 Decentralized, Rooftop Units

23 09 23. 13.A Smart Equipment (Unit based microprocessor control)

1. Shall be ASHRAE 62-2001 compliant.
2. Shall include an integrated economizer controller to support an economizer with 2 to 10 v DC actuator input.
3. Controller shall accept the following inputs: space temperature, setpoint adjustment, outdoor air temperature, indoor air quality, outdoor air quality, indoor relative humidity, compressor lockout, fire shutdown, enthalpy, fan status, remote time clock/door switch.
4. Shall accept a CO<sub>2</sub> sensor in the conditioned space, and be Demand Control Ventilation ready.
5. Unit shall provide surge protection for the controller through a circuit breaker.
6. Shall have an LED display independently showing the status of activity on the communication bus, and processor operation.
7. Software upgrades will be accomplished by local download. Software upgrades through chip replacements are not allowed.

- A. Unit shall be complete with self-contained low-voltage control circuit protected by a resettable circuit breaker on the 24-volt transformer side.
- B. Unit shall incorporate a lockout circuit which provides reset capability at the space thermostat or base unit should any of the following standard safety devices trip and shut off compressor:
  - C. Loss-of-charge/Low-pressureswitch.
  - D. High-pressure switch.
  - E. Freeze-protection thermostat, evaporator coil. If any of the above safety devices trip, an LED (light-emitting diode) indicator shall flash a diagnostic code that indicates which safety switch has tripped.
- F. Unit shall incorporate "AUTO RESET" compressor over temperature, over current protection.
- G. Unit shall operate with conventional thermostat designs and have a low voltage terminal strip for easy hook-up.
- H. Unit control board shall have on-board diagnostics and fault code display.
- I. Standard controls shall include anti-short cycle and low voltage protection, and permit cooling operation down to 0 °F.
- J. Control board shall monitor each refrigerant safety switch independently.
- K. Control board shall retain last 5 fault codes in non-volatile memory, which will not be lost in the event of a power loss.

23 09 23. 13.B RTU Open-multi-protocol, direct digital controller

- 1. Shall be ASHRAE 62-2001 compliant.
- 2. Shall include built-in protocol for BACNET , Modbus , and Johnson N2.
- 3. Shall allow access of up to 62 network variables (SNVT). Shall be compatible with all open controllers
- 4. Baud rate Controller shall be selectable using a dip switch.
- 5. Shall have an LED display independently showing the status of serial communication,running, errors, power, all digital outputs, and all analog inputs.
- 6. Shall accept the following inputs: space temperature, setpoint adjustment, outdoor air temperature, indoor air quality, outdoor air quality, compressor lock- out, fire shutdown, enthalpy switch, and fan status/filter status/ humidity/ remote occupancy.
- 7. Software upgrades will be accomplished by either local or remote download. No software upgrades through chip replacements are allowed.

**23 09 33 Electric and Electronic Control System for HVAC**

23 09 33. 13 Decentralized, Rooftop Units

23 09 33. 13.A General

- 1. Shall be complete with self- contained low- voltage control circuit protected by a resettable circuit breaker on the 24-v transformer side. Transformer shall have 75VA capability.
- 2. Shall utilize color-coded wiring.
- 3. Shall include a central control terminal board to conveniently and safely provide connection points for vital control functions such as: smoke detectors, phase monitor, gas controller, economizer, thermostat, DDC control options, and low and high pressure switches.
- 4. The heat exchanger shall be controlled by an integrated gas controller (IGC) microprocessor. See heat exchanger section of this specification.

23 09 33. 23.B Safeties

- 1. Compressor over-temperature, over-current. High internal pressure differential.
- 2. Low-pressure switch.
  - a. Units with 2 compressors shall have different sized connectors for the circuit 1 and circuit 2 low **and high** pressure switches. They shall physically prevent the cross- wiring of the safety switches between circuits 1 and 2.
  - b. Low pressure switch shall use different color wire than the high pressure switch. The purpose is to assist the installer and service technician to correctly wire and or troubleshoot the rooftop unit.
- 3. High pressure switch.
  - a. Units with 2 compressors shall have different sized connectors for the circuit 1 and circuit 2 **low and** high pressure switches. They shall physically prevent the cross-wiring of the safety switches between circuits 1 and 2.

- b. High pressure switch shall use different color wire than the low pressure switch. The purpose is to assist the installer and service technician to correctly wire and or troubleshoot the rooftop unit.

- 4. Automatic reset,/motor thermal overload protector.

**23 09 93                    Sequence of Operations for HVAC Controls**

23 09 93. 13      Decentralized, Rooftop Units

23 09 93. 13      INSERT SEQUENCE OF OPERATION

**23 40 13                    Panel Air Filters**

23 40 13. 13      Decentralized, Rooftop Units

23 40 13. 13.A    Standard filter section

- 1. Shall consist of factory-installed, low velocity, disposable 2" or 4" thick fiberglass filters of commercially available sizes.
- 2. Units can accept 2" or 4" filters and have a field convertible toolless
- 3. Filters shall be accessible through an access panel with toolless removal as described in the unit cabinet section of this specification (23 81 19.13.H).

**23 81 19                    Self-Contained Air Conditioners**

23 81 19. 13      Small-Capacity Self-Contained Air Conditioners

23 81 19. 13.A    General

- 1. Outdoor, rooftop mounted, electrically controlled, heating and cooling unit utilizing a fully hermetic scroll compressor(s) for cooling duty
- 2. Factory assembled, single-piece heating and cooling rooftop unit. Contained within the unit enclosure shall be all factory wiring, piping, controls, and special features required prior to field start-up.
- 3. Unit shall be installed in accordance with the manufacturer's instructions.
- 4. Unit must be selected and installed in compliance with local, state, and federal codes.

23 81 19. 13.B    Quality Assurance

- 1. Unit meets ASHRAE 90.1 minimum efficiency requirements.
- 3. Unit shall be rated in accordance with AHRI Standards 210/240 and 340/360.
- 4. Unit shall be designed to conform to ASHRAE 15, 2001.
- 5. Unit shall be UL- tested and certified in accordance with ANSI Z21.47 -2012/CSA 2.3-2012, CSA C22.2 No. 236-11 (UL 1995) 4th edition and CSA C22.2 No. 3 - M 1988
- 6. Insulation and adhesive shall meet NFPA 90A requirements for flame spread and smoke generation.
- 7. Unit casing shall be capable of withstanding 750-hour salt spray exposure per ASTM B117 (scribed specimen).
- 8. Unit shall be designed in accordance with ISO 9001, and shall be manufactured in a facility registered by; ISO 9001.
- 9. Roof curb shall be designed to conform to NRCA Standards.
- 10. Unit shall be subjected to a completely automated run test on the assembly line. The data for each unit; will be stored at the factory, and must be available upon request.
- 11. Unit shall be designed in accordance with UL Standard 1995, including tested to withstand rain.
- 12. Unit shake tested to assurance level 1, ASTM D4169 to ensure shipping reliability.
- 13. High Efficient Motors listed shall meet section 313 of the Energy Independence and Security Act of 2007; (EISA 2007).

23 81 19. 13.B    Delivery, Storage, and Handling

- 1. Unit shall be stored and handled per manufacturer's recommendations.

23 81 19. 13.E    Project Conditions

- 1. As specified in the contract.

23 81 19. 13.F    Operating Characteristics

- 1. Unit shall be capable of starting and running at 125°F (52°C) ambient outdoor temperature, meeting maximum load criteria of AHRI Standard 210/240 or 340/360 at ± 10% voltage.

2. Compressor with standard controls shall be capable of operation down to 0°F (2°C), ambient outdoor temperatures. See below for head pressure control package or winter start kit.
  3. Unit shall discharge supply air vertically or horizontally as shown on contract drawings.
  4. Unit shall be factory configured for vertical supply & return configurations.
  5. Unit shall be field convertible from vertical to horizontal airflow on all models.
  6. Unit shall be capable of mixed operation: vertical supply with horizontal return or horizontal supply with vertical return.
- 23 81 19. 13.G Electrical Requirements
1. Main power supply voltage, phase, and frequency must match those required by the manufacturer.
- 23 81 19. 13.H Unit Cabinet
1. **Unit cabinet shall be constructed of galvanized steel with exterior surfaces coated with a non-chalking, powder paint finish, certified at 750 hour salt spray test per ASTM-B117 standards.**
  2. Evaporator fan compartment interior cabinet insulation shall conform to AHRI Standards 210/240 or 340/360 minimum exterior sweat criteria. Interior surfaces shall be insulated with a minimum 1/2- in. thick, 1 1/2 lb density, flexible fiberglass insulation, neoprene coated on the air side. Aluminum foil- faced fiberglass insulation shall be used in the gas heat compartment. Fan shall be a belt drive assembly and include an adjustable pitch motor pulley. Job site selected brake horsepower shall not exceed the motors nameplate horsepower rating plus the service factor (Only premium efficiency motors have hp rating on the nameplate). Units shall be designed to operate within the service factor. Fan wheel shall be double inlet type with forward curve blades, dynamically balanced to operate smoothly throughout the entire range of operation. Airflow design shall be constant volume. Bearings shall be sealed and permanently lubricated for longer life and no maintenance.  
  
Condenser Fan Assembly: The outdoor fans shall be of the direct drive type, discharge air vertically, have aluminum blades riveted to corrosion resistant steel spider brackets and shall be dynamically balanced for smooth operation. The outdoor fan motors shall have permanently lubricated bearings internally protected against overload conditions and staged independently.
  3. Base of unit shall have a minimum of four locations for thru-the-base gas and electrical connections (factory installed or field installed), standard.
  4. Base Rail
    - a. Unit shall have base rails on a minimum of 4 sides.
    - b. Holes shall be provided in the base rails for rigging shackles to facilitate maneuvering and overhead rigging.
    - c. Holes shall be provided in the base rail for moving the rooftop by fork truck..
    - d. Base rail shall be a minimum of 16 gauge thickness.
  5. Condensate pan and connections
    - a. Shall be an internally sloped condensate drain pan made of a non-corrosive material.
    - b. Shall comply with ASHRAE Standard 62.
    - c. Shall use a 3/4" - 14 NPT drain connection, possible either through the bottom or side of the drain pan. Connection shall be made per manufacturer's recommendations.
  6. Top panel
    - a. Shall be a single piece top panel.
  8. Electrical Connections
    - a. All unit power wiring shall enter unit cabinet at a single, factory-prepared, knockout location.
    - b. Thru-the-base capability.
      - (1.) Standard unit shall have a thru-the-base electrical location(s) using a raised, embossed portion of the unit basepan.
      - (2.) Optional, factory- approved, water-tight connection method must be used for thru-the-base electrical connections.
      - (3.) No basepan penetration, other than those authorized by the manufacturer, is permitted.
  9. Component access panels (standard)
    - a. Cabinet panels shall be easily removable for servicing.
    - b. Unit shall have one factory installed, toolless, removable, filter access panel.
    - c. Panels covering control box, indoor fan, indoor fan motor, gas components(where applicable), and compressors shall have a molded composite handles.
    - d. Handles shall be UV modified, composite. They shall be permanently attached, and recessed into the panel.

- e. Screws on the vertical portion of all removable access panel shall engage into heat resistant, molded composite collars.
  - f. Collars shall be removable and easily replaceable using manufacturer recommended parts.
- 23 81 19. 13.J Coils
- 1. Standard Aluminum Fin/Copper Tube Coils
    - a. Standard evaporator and condenser coils shall have aluminum lanced plate fins mechanically bonded to seamless internally grooved copper tubes with all joints brazed.
    - b. Evaporator coils shall be leak tested to 150 psig, pressure tested to 450 psig, and qualified to CSA C22.2 No. 236-11 (UL 1995) 4th edition burst test at 1775 psig.
    - c. Condenser coils shall be leak tested to 150 psig, pressure tested to 650 psig, and qualified to CSA C22.2 No. 236-11 (UL 1995) 4th edition burst test at 1980 psig.
- 23 81 19. 13.K Refrigerant Components
- 1. Refrigerant circuit shall include the following control, safety, and maintenance features
    - a. Thermostatic Expansion Valve (TXV) shall help provide optimum performance across the entire operating range. Shall contain removable power element to allow change out of power element and bulb without removing the valve body.(Orifice on ZX08, ZX09, ZX12, ZQ04, ZQ05 & ZQ06)
    - b. Refrigerant filter drier - Solid core design.
    - c. Service gauge connections on suction and discharge lines.
    - d. Pressure gauge access through a specially designed access port in the top panel of the unit.
  - 2. There shall be gauge line access port in the skin of the rooftop, covered by a black, removable plug.
    - a. The plug shall be easy to remove and replace.
    - b. When the plug is removed, the gauge access port shall enable maintenance personnel to route their pressure gauge lines.
    - c. This gauge access port shall facilitate correct and accurate condenser pressure readings by enabling the reading with the compressor access panel on.
    - d. The plug shall be made of a leak proof, UV- resistant, composite material.
  - 3. Compressors
    - a. Unit shall use fully hermetic, scroll compressor for each independent refrigeration circuit.
    - b. Compressor motors shall be cooled by refrigerant gas passing through motor windings.
    - c. Compressors shall be internally protected from high discharge temperature conditions.
    - d. Compressors shall be protected from an over-temperature and over-amperage conditions by an internal, motor overload device.
    - e. Compressor shall be factory mounted on rubber grommets.
    - f. Compressor motors shall have internal line break thermal, current overload and high pressure differential protection.
    - g. Crankcase heaters shall not be required for normal operating range, unless provided by the factory.
- 23 81 19. 13.L Filter Section
- 1. Filters access is specified in the unit cabinet section of this specification.
  - 2. Shall consist of factory-installed, low velocity, throw-away 2" or 4" thick fiberglass filters.
  - 3. Units can accept 2" or 4" filters and have a field convertible toolless
- 23 81 19. 13.M Evaporator Fan and Motor
- 1. Evaporator fan motor
    - a. Shall have permanently lubricated bearings.
    - b. Shall have inherent automatic reset thermal protection (Only on single-phase, belt-drive motors, three - phase, belt-drive motors have internal thermostat used for external line-break control.).
  - 3. Belt-driven Evaporator Fan
    - a. Belt drive shall include an adjustable-pitch motor pulley.
    - b. Shall use sealed, permanently lubricated ball-bearing type.
    - c. Blower fan shall be double-inlet type with forward-curved blades.
    - d. Shall be constructed from steel with a corrosion resistant finish and dynamically balanced.

23 81 19. 13.N Condenser Fans and Motors

The outdoor fans shall be of the direct drive type, discharge air vertically, have aluminum blades riveted to corrosion resistant steel spider brackets and shall be dynamically balanced for smooth operation. The outdoor fan motors shall have permanently lubricated 60°C ball bearings internally protected against overload conditions and staged independently. A cleaning window shall be provided on two sides of the units for coil cleaning.

1. Condenser fan motors
  - a. Shall be a totally enclosed motor.
  - b. Shall use permanently lubricated bearings.
  - c. Shall have inherent thermal overload protection with an automatic reset feature.
  - d. All models shall use a shaft-down design except shaft-up on ZX14 & ZY12 size with rain shield.

2. Condenser Fans

- a. Shall be a direct-driven propeller type fan.
- b. Shall have aluminum blades riveted to corrosion-resistant steel spiders and shall be dynamically balanced.

23 81 19. 13.O Special Features Options and Accessories

8. Unit- Mounted, Non-Fused Disconnect Switch: (Verify on the unit nameplate that the disconnect is properly sized for the application. Units with field installed electric heat may exceed the factory installed disconnect amperage rating.)

- a. Switch shall be factory- installed, internally mounted.
- b. National Electric Code (NEC) and UL approved non- fused switch shall provide unit power shutoff.
- c. Shall be accessible from outside the unit.
- d. Shall provide local shutdown and lockout capability.

13. Outdoor Air Enthalpy Sensor:

- a. The outdoor air enthalpy sensor shall be used to provide single enthalpy control. When used in conjunction with a return air enthalpy sensor, the unit will provide differential enthalpy control. The sensor allows the unit to determine if outside air is suitable for free cooling.

14. Return Air Enthalpy Sensor:

- a. The return air enthalpy sensor shall be used in conjunction with an outdoor air enthalpy sensor to provide differential enthalpy control.

15. Indoor Air Quality (CO<sub>2</sub>)Sensor:

- a. Shall be able to provide demand ventilation indoor air quality (IAQ) control.
- b. The IAQ sensor shall be available in duct mount, wall mount, or wall mount with LED display. The set-point shall have adjustment capability.
- c. Shall be environmental compensated with differential sensing for reliable, stable, and drift- free sensitivity.
- d. Shall use magnet-activated test/reset sensor switches.
- e. Shall have tool-less connection terminal access.

## GENERAL

York® Sun™ Pro units are convertible single packages with a common footprint cabinet and common roof curb for all 6-1/2 through 12-1/2 ton models. All have two compressors with independent refrigeration circuits to provide 2 stages of cooling. The units were designed for light commercial applications and can be easily installed on a roof curb, slab, or frame. All units are self contained and assembled on rigid full perimeter base rails allowing for 3-way forklift access and overhead rigging. Every unit is completely charged with refrigerant, wired, piped, and tested at the factory to provide a quick and easy field installation. All units are convertible between side and down airflow. Independent economizer designs are used on side and down discharge applications, as well as all tonnage sizes. Predator® units are available in the following configurations: cooling only, cooling with electric heat, cooling with gas heat, reheat only, reheat with electric heat and reheat with gas heat. Electric heaters are available as factory-installed options or field-installed accessories.

## DESCRIPTION

Units shall be factory assembled, single package, (Elec/Elec, Gas/ Elec), designed for outdoor installation. They shall have built in field convertible duct connections for down discharge supply/return or horizontal discharge supply/return and be available with factory installed options or field installed accessories. The units shall be factory wired, piped and charged with refrigerant and factory tested prior to shipment. All unit wiring shall be both numbered and color coded. The cooling performance shall be rated in accordance with DOE and AHRI test procedures. Units shall be CSA certified to ANSI Z21.47 and UL 1995/CAN/CSA No. 236-M90 standards.

## UNIT CABINET

Unit cabinet shall be constructed of galvanized steel with exterior surfaces coated with a non-chalking, powder paint finish, certified at a 750-hour salt spray test per ASTM-B117 standards. Indoor blower sections shall be insulated with up to 1" thick insulation coated on the airside. Either aluminum foil faced or elastometric rubber insulation shall be used in the unit's compartments and be fastened to prevent insulation from entering the air stream. Cabinet doors shall be hinged with toolless access for easy servicing and maintenance. Full perimeter base rails shall be provided to assure reliable transit of equipment, overhead rigging, fork truck access and proper sealing on roof curb applications. Disposable 2" filters shall be furnished as standard and be accessible through hinged access door. Fan performance measuring ports shall be provided on the outside of the cabinet to allow accurate air measurements of evaporator fan performance without removing panels or creating bypass of the coils.

Condensate pan shall be slide out design, constructed of a non corrosive material, internally sloped and conforming to ASHRAE 62-B9 standards. Condensate connection shall be a minimum of 3/4" I.D. female and be rigid mount connection.

## INDOOR (EVAPORATOR) FAN ASSEMBLY

Fan shall be a belt drive assembly and include an adjustable pitch motor pulley. Job site selected brake horsepower shall not exceed the motors nameplate horsepower rating plus the service factor. Units shall be designed to operate within the service factor. Fan wheel shall be double inlet type with forward curve blades, dynamically balanced to operate smoothly throughout the entire range of operation. Airflow design shall be constant volume. Bearings shall be sealed and permanently lubricated for longer life and no maintenance. Entire blower assembly and motor shall be slide out design.

## OUTDOOR (CONDENSER) FAN ASSEMBLY

The outdoor fans shall be of the direct drive type, discharge air vertically, have aluminum blades riveted to corrosion resistant steel spider brackets and shall be dynamically balanced for smooth operation. The outdoor fan motors shall have permanently lubricated bearings internally protected against overload conditions and staged independently. A cleaning window shall be provided on two sides of the units for coil cleaning.

## REFRIGERANT COMPONENTS

### Compressors:

- a. Shall be fully hermetic type, direct drive, internally protected with internal high-pressure relief and over temperature protection. The hermetic motor shall be suction gas cooled and have a voltage range of + or - 10% of the unit nameplate voltage.
- b. Shall have internal spring isolation and sound muffling to minimize vibration and noise, and be externally isolated on a dedicated, independent mounting.

### Coils:

- a. Evaporator coils shall have aluminum plate fins mechanically bonded to seamless internally enhanced copper tubes with all joints brazed. Special Phenolic coating shall be available as a factory option.
- b. Evaporator coils shall be of the direct expansion, draw-thru design.
- c. Condenser coils shall have aluminum plate fins mechanically bonded to seamless internally enhanced copper tubes with all joints brazed or Micro-Channel aluminum tube, aluminum fins.
- d. Condenser coils shall be of the draw-thru design.

Refrigerant Circuit and Refrigerant Safety Components shall include:

- a. Independent fixed-orifice or thermally operated expansion devices.
- b. Solid core filter drier/strainer to eliminate any moisture or foreign matter.
- c. Accessible service gage connections on both suction and discharge lines to charge, evacuate, and measure refrigerant pressure during any necessary servicing or troubleshooting, without losing charge.
- d. The unit shall have two independent refrigerant circuits, equally split in 50% capacity increments.

Unit Controls:

- a. Unit shall be complete with self-contained low-voltage control circuit protected by a resettable circuit breaker on the 24-volt transformer side.
- b. Unit shall incorporate a lockout circuit which provides reset capability at the space thermostat or base unit should any of the following standard safety devices trip and shut off compressor:
  - Loss-of-charge/Low-pressure switch.
  - High-pressure switch.
  - Freeze condition sensor on evaporator coil. If any of these safety devices trip, the LCD screen will display the alarm message.
- c. Unit shall incorporate "AUTO RESET" compressor over temperature, over current protection.
- d. Unit shall operate with conventional thermostat designs and have a low voltage terminal strip for easy hook-up.
- e. Unit control board shall have on-board diagnostics and fault message display.
- f. Standard controls shall include anti-short cycle and low voltage protection, and permit cooling operation down to a selectable value as low as 0 °F.
- g. Control board shall monitor each refrigerant safety switch independently.

## ELECTRIC HEATING SECTION

An electric heating section, with nickel chromium elements, shall be provided in a range of 9 thru 54KW. The heating section shall have a primary limit control(s) (automatic reset) to prevent the heating element system from operating at an excessive temperature. The Heating Section assembly shall slide out of the unit for easy maintenance and service. Units with Electric Heating Sections shall be wired for a single point power supply with branch circuit fusing (where required).

## UNIT OPERATING CHARACTERISTICS

Unit shall be capable of starting and running at 125 °F outdoor temperature, exceeding maximum load criteria of AHRI Standard 340/360. The compressor, with standard controls, shall be capable of operation down to 0 °F outdoor temperature.

**ELECTRICAL REQUIREMENTS** - All unit power wiring shall enter unit cabinet at a single factory provided location and be capable of side or bottom entry to minimize roof penetrations and avoid unit field modifications. Separate side and bottom openings shall be provided for the control wiring.

**STANDARD LIMITED WARRANTIES** - Compressor – 5 Years, Heat Exchanger – 10 Years, Elect. Heat Elem. – 5 Years, Parts – 1 Year.

**FACTORY INSTALLED OPTIONAL OUTDOOR AIR** (Shall be made available by either/or):

## ADDITIONAL FACTORY INSTALLED OPTIONS

- **Alternate Indoor Blower Motor** – For applications with high restrictions, units are available with optional indoor blower motors that provide higher static output and/or higher airflow.
- **IntelliSpeed™ Supply Fan Control Option (ASHRAE 90.1 compliant, section 6.4.3.10)** – Units configured with the IntelliSpeed™ Supply Fan Option will contain a VFD for variable volume supply fan operation. This option allows the supply fan RPM to vary based on the number of compressors or heating stages energized. The economizer's minimum position will also be configurable to vary based on the supply fan VFD frequency output.
- **Powered Convenience Outlet** – Unit is provided with an internally powered 120VAC GFCI outlet with cover on the corner of the unit housing the compressors.
- **Electric Heat** – Electric Heaters range from 9 thru 54KW and are available in all the voltage options of the base unit.
- **BAS Controls** – Include supply air sensor, return air sensor, dirty filter indicator and air proving switch.

## FIELD INSTALLED OPTIONS



**Guide Specification for  
York® Sun™ Pro**

- **Burglar Bars** – Mount in the supply and return openings to prevent entry into the duct work.

**Date**

03/10/2025

**Project Name**

BCF 406 Salem OR

**Project Number**

**Client / Purchaser**



### Control Summary Page

Control	Models and Unit Tags
BACnet MSTP,MdbS,N2 COM Card	KV20E1CR4U1CAP81F1 RTU 1, 2
	KJ150E54U4DFACA1A1 RTU 5
BACnet MSTP,MdbS,N2 COM Card	KYE06A4B1AB5G323A1 RTU 4

**23 09 23 Direct- digital Control system for HVAC**23 09 23. 13 Decentralized, Rooftop Units:23 09 23. 13.A. Unit Control Board

1. ASHRAE 62- 2001 compliant. BTL certified.
2. Shall accept 20-30 VAC input power, 50/60Hz. 24 VAC nominal.
3. Operating temperature range from -40F to 158F; 10-90% RH (non-condensing UI), and -4F to 158F; 10-90% Rh (non-condensing), with a storage temperature range from -40F to 194F; 5-95% RH (non-condensing).
4. Shall include an option of and Economizer microprocessor controller which communicates directly with the Unit Control Board and has 8 Analog outputs, 2 Analog inputs, 2 Binary outputs, 3 Binary outputs.
5. Controller shall accept the following inputs: space temperature, return air temperature sensor, setpoint adjustment, outdoor air temperature, indoor air quality, outdoor air quality, indoor relative humidity, compressor lock- out, fire/smoke shutdown, single and dual enthalpy, fan status, remote time clock, SA Bus communicated temperature/humidity/CO2 values from Network sensors, FC Bus Network Overrides for space temperature, outdoor air temperature, space humidity, outdoor air quality, Indoor air quality, System purge.
6. Shall accept a single CO2 sensor or multiple CO2 sensors networked together via communication bus in the conditioned space, and be Demand Control Ventilation (DCV) ready.
7. Shall provide the following outputs: economizer, fan, cooling stage 1, cooling stage 2, heat stage 1, heat stage 2, heat stage 3/ exhaust/ reversing valve/ dehumidify/occupied.
8. Unit shall provide surge protection for the controller through a circuit breaker.
9. Shall be Internet capable, and communicate at a Baud rate of 38.4K or faster.
10. Shall have an LED display independently showing the status of activity on the communication bus, and processor operation.
11. Unit shall incorporate a lockout circuit which provides reset capability at the space thermostat or base unit should any of the following standard safety devices trip and shut off compressor. If any of these safety devices trip, the LCD screen will display alarm message indicating the specific safety device that caused the lockout.
  - a. Loss of charge/Low-pressure switch.
  - b. High-pressure switch.
  - c. Freeze condition sensor on evaporator coil.
12. Unit control board must support each usage case:
  - a. Conventional thermostat with low voltage input terminals for easy installation
  - b. Communicating network sensors in the occupied space to provide feedback on space conditions for unit control board to compare with associated setpoints
  - c. Communication via BACnet MS/TP, Modbus RTU, N2 protocols for integration into a building automation/management system
13. Anti-short cycle and low voltage protection features included.
14. Internal occupied/unoccupied scheduling
15. Unit control board shall permit cooling operation down to a selectable value as low as 0 degrees F.
16. Shall allow for start-up, commissioning, troubleshooting, parameter adjustment, setpoint adjustment via onboard display and navigable menu with no additional interface tool or controls technician required.
17. The unit control board shall run a self-test diagnostics algorithm at startup that operated the cooling cycle, heating cycle, fan operation. A status report shall be provided upon completion of the diagnostic self-test.
18. Utilize any wi-fi enabled smart device to access the HVAC or multiple HVAC units if communication wiring between them is present (FC Bus or SA Bus). Remote access shall allow complete ability to perform start-up, commissioning, troubleshooting, parameter adjustment, setpoint adjustment.
19. Local embedded trending and scheduling. Trending data and occupancy scheduling predefined from the factory. Occupancy schedule to be modified via control board joystick menu navigation and remotely using a smart device (cellular phone, laptop, tablet)
20. A menu on the onboard screen shall display the unit status and allow changing parameters where applicable. These include but are not limited to:
  - a. Demand Ventilation Mode – enable or disable
  - b. Operational Setpoint – display current value
  - c. Supply Air Temperature (SAT) – display current value
  - d. Return Air Temperature (RAT) – display current value

- e. Operational Supply Humidity (OprSH) – display current value as provided by a 0-10VDS input, SA Bus Network Sensor, or FC Bus communicated value
  - f. Return Air Humidity (RAH) – display current value
  - g. Operational outdoor Air Temperature (OprOAT) – enthalpy calculated from OAH 0-10VDC input to Economizer board and OprOAT only if economizer is present
  - h. Operational Outdoor Air Humidity (OprOAH) – the buffered outdoor air humidity. May be from economizer boards OAH 0-10VDC input or FC Bus communicated value
  - i. Operational outdoor Air Quality (OprOAQ) – the buffered outdoor air quality in use. May be from economizer boards OAQ 0-10VDC input or FC Bus communicated value
  - j. Operational Indoor Air Quality (OprIAQ) – the buffered indoor air quality in use. May be from economizer board IAQ 0-10VDC input, SA Bus Network Sensor, or FC Bus communicated value
21. A menu shall display and allow modification to the following operations and settings:
- a. HVAC Zone Fan
  - b. Cooling
  - c. Heating
  - d. Economizer
  - e. Demand Ventilation
  - f. Power Exhaust
  - g. Sensors
  - h. Network
22. A menu shall display and allow modification to the following operations and settings:
- a. HVAC Zone – Occupied status
  - b. Indoor Fan status
  - c. Cooling status
  - d. Heating status
  - e. Economizer indication whether free-cooling is available or not
  - f. Enabling or disabling of Demand Ventilation
  - g. Power Exhaust
    - 1) Enable/disable hot-gas reheat if available
    - 2) Warmup/Cooldown
    - 3) Title 24 Load Shed
    - 4) Defrost
23. A menu shall display and allow modification to the following operations and settings:
- a. Firmware version (of UCB, Economizer, other peripheral boards)
  - b. Setting time zone
  - c. Network information
    - 1) Device name that will appear on the FC Bus
    - 2) Selection of communication protocol
    - 3) Operational Baud Rate
    - 4) Device ID
24. A menu shall display and allow modification to the following operations and settings:
- a. Version of firmware
  - b. Ability to Load new firmware
  - c. Create a backup file of the firmware and parameter setting via USB port
  - d. Restore factory default parameter values and setup
  - e. Full and Partial Cloning of parameter setpoints from or to other units
  - f. Data trend exporting
25. A menu shall display and allow modification to the following operations and settings:

- a. Unit serial number, model number and name
- b. Ability to reset Lockouts
- c. Controller name
- d. Displays the current values of all setpoints in use
- e. Displays all current values for the indoor and outdoor zones
- f. Displays current values related to:
  - 1) Indoor Fan
  - 2) Cooling
  - 3) Heating
  - 4) Heat Pump operation
  - 5) Economizer operation
  - 6) Power Exhaust
  - 7) Demand Ventilation
  - 8) Air monitoring station
  - 9) Hot Gas Reheat
  - 10) Smoke Control
- g. Current information for inputs; including
  - 1) Sensors
  - 2) Coil Sensors
  - 3) Thermostat
  - 4) Binary Inputs
  - 5) Unit Protection
  - 6) Network Inputs
  - 7) All outputs (relay and binary)
- h. Self-Test
  - 1) A patented self-test system that runs through a series of algorithms to provide a report of all functioning characteristics of the system at time of startup and commissioning.

23 09 23. 13.B. Auxiliary Control Boards

1. ASHRAE 62- 2001 compliant. BTL certified.
2. Economizer controller CEC Title 24 Compliant
  - a. Display alarms if the following occur
    - 1) Economizer is economizing when conditions do not support
    - 2) Economizer is not economizing when conditions do support
    - 3) Damper Stuck
    - 4) Excess Outdoor Air
    - 5) Failed Sensor
3. Refrigeration Fault Detection & Diagnostics
  - a. There is insufficient refrigerant in any circuit
  - b. There is excessive refrigerant in any circuit
  - c. There is excessive refrigerant flow
  - d. There is insufficient refrigerant flow (restriction)
  - e. Inefficient compressor
  - f. Insufficient High-side heat transfer
  - g. Excessive High-side heat transfer (low ambient control problem, low  $\Delta P$ )
  - h. Insufficient Low-side heat transfer
  - i. Excessive Low-side heat transfer

- j. Sensor fault- The liquid temperature is greater than the condenser temperature (Could also be triggered if refrigerant level is very low in the system)
- k. Sensor fault- Sensor data is not available
- l. The unit is off
- m. The ambient temperature is too low
- n. The ambient temperature is too high
- o. The return air wet-bulb temperature is too low
- p. The return air wet-bulb temperature is too high
- q. Sensor fault- The condensing temperature is lower than the ambient temperature (Could also be triggered when the condenser is wet)
- r. The suction line temperature is less than the evaporator temperature
- s. The evaporator temperature is greater than the ambient temperature
- t. The liquid temperature is lower than the ambient temperature
- u. Sensor fault- Suction temperature or ambient temperature is invalid
- v. Sensor fault- The return air dry-bulb or wet-bulb temperature is invalid
- w. Sensor fault- The liquid pressure or suction pressure is invalid
- x. Sensor fault- The suction line temperature is invalid
- y. The return air dry-bulb temperature is too low
- z. The return air dry-bulb temperature is too high
- aa. The Efficiency Index is below 75% of ideal
- bb. The Capacity Index is below 75% of ideal

23 09 23. 13.C Remote Accessibility:

1. ASHRAE 62- 2001 compliant. BTL certified.
2. Provide the ability to adjust parameter values, setpoints, limits remotely
3. Connectivity to an Ethernet network via static IP address or Dynamic Name Server (DNS)
4. Allow a maximum of 100 devices on the same FC bus trunk and accessed by one remote device

# Start-up sheet

## START-UP & SERVICE DATA INSTRUCTION

### COMMERCIAL PACKAGE UNITS

3.0 To 50.0 TONS

#### START-UP CHECKLIST

Date: \_\_\_\_\_

Job Name: \_\_\_\_\_

Customer Name: \_\_\_\_\_

Address: \_\_\_\_\_

City: \_\_\_\_\_ State: \_\_\_\_\_ Zip: \_\_\_\_\_

Model Number: \_\_\_\_\_ Serial Number: \_\_\_\_\_

Qualified Start-up Technician: \_\_\_\_\_ Signature: \_\_\_\_\_

HVAC Contractor: \_\_\_\_\_ Phone: \_\_\_\_\_

Address: \_\_\_\_\_

Contractor's E-mail Address: \_\_\_\_\_

Electrical Contractor: \_\_\_\_\_ Phone: \_\_\_\_\_

Distributor Name: \_\_\_\_\_ Phone: \_\_\_\_\_

#### WARRANTY STATEMENT

Johnson Controls/Ducted Systems is confident that this equipment will operate to the owner's satisfaction if the proper procedures are followed and checks are made at initial start-up. This confidence is supported by the 30 day dealer protection coverage portion of our standard warranty policy which states that Johnson Controls/Ducted Systems will cover parts and labor on new equipment start-up failures that are caused by a defect in factory workmanship or material, for a period of 30 days from installation. Refer to the current standard warranty policy and warranty manual for details.

In the event that communication with Johnson Controls/Ducted Systems is required regarding technical and/or warranty concerns, all parties to the discussion should have a copy of the equipment start-up sheet for reference. A copy of the original start-up sheet should be filed with the Technical Services Department.

The packaged unit is available in constant or variable air volume versions with a large variety of custom options and accessories available. Therefore, some variation in the startup procedure will exist depending upon the products capacity, control system, options and accessories installed.

This start-up sheet covers all startup check points common to all package equipment. In addition it covers essential startup check points for a number of common installation options. Depending upon the particular unit being started not all sections of this startup sheet will apply. Complete those sections applicable and use the notes section to record any additional information pertinent to your particular installation.

Warranty claims are to be made through the distributor from whom the equipment was purchased.

#### EQUIPMENT STARTUP

Use the local LCD or Mobile Access Portal (MAP) Gateway to complete the start-up.

A copy of the completed start-up sheet should be kept on file by the distributor providing the equipment and a copy sent to:

Johnson Controls/Ducted Systems  
 Technical Services Department  
 5005 York Drive  
 Norman, OK 73069

**SAFETY WARNINGS**

The inspections and recording of data outlined in this procedure are required for start-up of Johnson Controls/Ducted Systems' packaged products. Industry recognized safety standards and practices must be observed at all times. General industry knowledge and experience are required to assure technician safety. It is the responsibility of the technician to assess all potential dangers and take all steps warranted to perform the work in a safe manner. By addressing those potential dangers, prior to beginning any work, the technician can perform the work in a safe manner with minimal risk of injury.

<b>⚠ WARNING</b>
Lethal voltages are present during some start-up checks. Extreme caution must be used at all times.

<b>⚠ WARNING</b>
Moving parts may be exposed during some startup checks. Extreme caution must be used at all times.

**NOTE:** Read and review this entire document before beginning any of the startup procedures.

**DESIGN APPLICATION INFORMATION**

This information will be available from the specifying engineer who selected the equipment. If the system is a VAV system the CFM will be the airflow when the remote VAV boxes are in the

full open position and the frequency drive is operating at 60 HZ. **Do not proceed with the equipment start-up without the design CFM information.**

Design Supply Air CFM: \_\_\_\_\_ Design Return Air CFM: \_\_\_\_\_

Design Outdoor Air CFM At Minimum Position: \_\_\_\_\_

Total External Static Pressure: \_\_\_\_\_

Supply Static Pressure: \_\_\_\_\_

Return Static Pressure: \_\_\_\_\_

Design Building Static Pressure: \_\_\_\_\_

Outside Air Dilution: Economizer Position Percentage: \_\_\_\_\_ CFM: \_\_\_\_\_

Supply Gas Pressure After Regulator W/o Heat Active \_\_\_\_\_ Inches \_\_\_\_\_

ADDITIONAL APPLICATION NOTES FROM SPECIFYING ENGINEER:

## REFERENCE

General Inspection	Completed	See Notes
Unit inspected for shipping, storage, or rigging damage	<input type="checkbox"/>	<input type="checkbox"/>
Unit installed with proper clearances	<input type="checkbox"/>	<input type="checkbox"/>
Unit installed within slope limitations	<input type="checkbox"/>	<input type="checkbox"/>
Refrigeration system checked for gross leaks (presence of oil)	<input type="checkbox"/>	<input type="checkbox"/>
Terminal screws and wiring connections checked for tightness	<input type="checkbox"/>	<input type="checkbox"/>
Filters installed correctly and clean	<input type="checkbox"/>	<input type="checkbox"/>
Economizer hoods installed in operating position	<input type="checkbox"/>	<input type="checkbox"/>
Condensate drain trapped properly, refer to Installation Manual	<input type="checkbox"/>	<input type="checkbox"/>
Economizer damper linkage tight	<input type="checkbox"/>	<input type="checkbox"/>
Gas Heat vent hood installed	<input type="checkbox"/>	<input type="checkbox"/>
All field wiring (power and control) complete	<input type="checkbox"/>	<input type="checkbox"/>

Air Moving Inspection	Completed	See Notes
Alignment of drive components	<input type="checkbox"/>	<input type="checkbox"/>
Belt tension adjusted properly	<input type="checkbox"/>	<input type="checkbox"/>
Blower pulleys tight on shaft, bearing set screws tight, wheel tight to shaft	<input type="checkbox"/>	<input type="checkbox"/>
Pressure switch or transducer tubing installed properly	<input type="checkbox"/>	<input type="checkbox"/>

Exhaust Inspection Powered <input type="checkbox"/> Barometric Relief <input type="checkbox"/>	Completed	See Notes
Check hub for tightness	<input type="checkbox"/>	<input type="checkbox"/>
Check fan blade for clearance	<input type="checkbox"/>	<input type="checkbox"/>
Check for proper rotation	<input type="checkbox"/>	<input type="checkbox"/>
Check for proper mounting (screen faces towards unit)	<input type="checkbox"/>	<input type="checkbox"/>
Prove operation by increasing minimum setting on economizer	<input type="checkbox"/>	<input type="checkbox"/>

Economizer Inspection Standard <input type="checkbox"/> BAS <input type="checkbox"/>	Completed	See Notes
CO <sub>2</sub> sensor installed Yes <input type="checkbox"/> No <input type="checkbox"/>	<input type="checkbox"/>	<input type="checkbox"/>
Check economizer setting (Reference Smart Equipment™ Control Board LCD menu location)	<input type="checkbox"/>	<input type="checkbox"/>
Prove economizer open/close through Smart Equipment™ Board Setting	<input type="checkbox"/>	<input type="checkbox"/>

Reheat Mode Normal <input type="checkbox"/> or Alternate <input type="checkbox"/> Not Applicable <input type="checkbox"/>
Humidity Sensor (2SH0401) _____

### Operating Measurements - Air Flow

Fan operates with proper rotation (All VFD equipped units with the optional Manual Bypass must be phased for correct blower rotation with the Bypass switch set in the LINE position) ID Fans  Exh. Fans  Cond. Fans

Pressure drop across dry evaporator coil (At maximum design CFM) <sup>1</sup>	IWC
External Static Pressure	IWC
Return Static Pressure	IWC
Supply Static Pressure	IWC
Supply Air CFM Using Dry Coil Chart	CFM
Final Adjusted Supply Air CFM <sup>2</sup>	CFM

1. Consult the proper airflow to pressure drop table to obtain the actual airflow at the measured pressure differential.
2. Was a motor pulley adjustment or change required to obtain the correct airflow?  
 Was it necessary to increase or decrease the airflow to meet the design conditions?  
 If the motor pulley size was changed, measure the outside diameters of the motor and blower pulleys and record those diameters here:  
 Blower Motor HP \_\_\_\_\_ FLA \_\_\_\_\_ RPM \_\_\_\_\_  
 Pulley Pitch Diameter \_\_\_\_\_ Turns Out \_\_\_\_\_ Final Turns Out \_\_\_\_\_  
 Blower Pulley Pitch Diameter \_\_\_\_\_ Fixed Sheave \_\_\_\_\_

### ELECTRICAL DATA

T1 - T2 \_\_\_\_\_ Volts                      T2 - T3 \_\_\_\_\_ Volts  
 Control Voltage \_\_\_\_\_ Volts                      T1 - T3 \_\_\_\_\_ Volts

Device	Nameplate	Measured List All Three Amperages
Supply Fan Motor <sup>1,2</sup>	AMPS	AMPS
Exhaust Motor (Dampers 100%)	AMPS	AMPS
Condenser Fan #1	AMPS	AMPS
Condenser Fan #2 (if equipped)	AMPS	AMPS
Condenser Fan #3 (if equipped)	AMPS	AMPS
Condenser Fan #4 (if equipped)	AMPS	AMPS
Compressor #1	AMPS	AMPS
Compressor #2 (if equipped)	AMPS	AMPS
Compressor #3 (if equipped)	AMPS	AMPS
Compressor #4 (if equipped)	AMPS	AMPS

1. VAV units with heat section - simulate heat call to drive VAV boxes and VFD/IGV to maximum design airflow position.
2. VAV units without heat section - VAV boxes must be set to maximum design airflow position.



