

**MECHANICAL FLOOR PLAN**  
 1/4" = 1'-0"  
 TRUE NORTH    PLAN NORTH

**MECHANICAL NOTES BY SYMBOL "⬡"**

- 1 MOUNT SIDEWALL DIFFUSERS TIGHT TO CEILING CENTERED BETWEEN DECORATIVE BEAMS.
- 2 MOUNT LINEAR SLOT DIFFUSERS IN SOFFIT.
- 3 COOLER CONDENSER ON ROOF AT THIS LOCATION.
- 4 UNDERCUT DOOR BY 1/2".
- 5 DUCT RTU RETURN DOWN TO (4) RETURN GRILLES. TRANSITION AS REQUIRED.
- 6 SWEETGREEN SHALL FURNISH AND CONTRACTOR SHALL INSTALL A REME HALO AIR PURIFICATION SYSTEM IN SUPPLY AIR DUCT DROP. ADJUST AS REQUIRED FOR THE SUPPLY AIRFLOW. INSTALL PER THE MANUFACTURER'S INSTALLATION INSTRUCTIONS.
- 7 ENSURE EXHAUST FAN IS 10' MINIMUM FROM ALL OUTSIDE AIR INTAKES.
- 8 WATER HEATER COMMON VENT THROUGH ROOF. PROVIDE WITH ROOF CAP AND BIRDSCREEN.
- 9 COORDINATE EXACT LOCATION OF EXHAUST FAN AND WATER HEATER INTAKE/FLUE WITH OTHER EQUIPMENT ON ROOF PRIOR TO CONSTRUCTION.
- 10 RTU-2 TO DISABLE MECHANICAL COOLING AND HEATING WHEN PATIO DOORS ARE OPEN. PROVIDE DOOR SWITCHES BETWEEN THERMOSTAT SIGNAL AND RTU AS REQUIRED.



**sweetgreen**

3101 W. EXPOSITION BLVD.  
 LOS ANGELES, CALIFORNIA 90018

THESE DRAWINGS & SPECIFICATIONS ARE CONFIDENTIAL AND SHALL REMAIN THE SOLE PROPERTY OF SWEETGREEN CORPORATION. THEY SHALL NOT BE REPRODUCED IN WHOLE OR IN PART, SHARED WITH THIRD PARTIES OR USED IN ANY MANNER ON OTHER PROJECTS OR EXTENSIONS TO THIS PROJECT WITHOUT THE PRIOR WRITTEN CONSENT OF SWEETGREEN CORPORATION. THESE DRAWINGS & SPECIFICATIONS ARE INTENDED TO EXPRESS DESIGN INTENT FOR A PROTOTYPICAL SWEETGREEN STORE (WHICH IS SUBJECT TO CHANGE AT ANY TIME) AND MAY NOT REFLECT ACTUAL SITE CONDITIONS. NEITHER PARTY SHALL HAVE ANY OBLIGATION NOR LIABILITY TO THE OTHER (EXCEPT AS STATED ABOVE) UNTIL A WRITTEN AGREEMENT IS FULLY EXECUTED.

ARCHITECT OF RECORD:



**ARCHITECTS**  
 FOOD + HOSPITALITY

FIRM REGISTRATION NO. BR 3045

STAMP:

**OLO LINE REVISION**  
 4-12-22

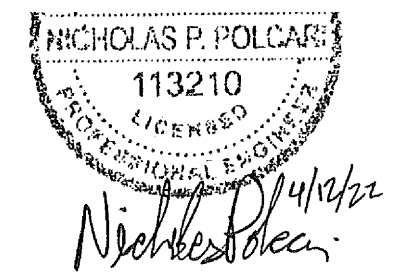

PROJECT INFORMATION:  
**LAKewood**

PROJECT INFORMATION:  
**6400 GASTON AVE.  
 DALLAS, TX 75214**

DRAWN BY: MB  
 CHECKED BY: ST  
 PROJECT MANAGER: ST  
 SG DESIGN MANAGER: KP  
 SG CONSTR. MANAGER: JB  
 PROJECT NO: 111020  
 TEMPLATE VERSION: 04/30/2021

REVISIONS  
 REV. DATE DESCRIPTION  
 6 4-12-22 OLO LINE CHANGES

**MECHANICAL PLAN**

RECEIVED BY D4 CONSTRUCTION  
 DATE: 04/12/2022

**M100**

**JFTE** James F. Turner  
 Engineers, L.P.  
 Consulting Engineers  
 8340 Meadow Rd, Suite 160  
 Dallas, Texas 75231  
 TEL. 214-750-2900  
 TX REGISTRATION # 11113  
 OC/APPC/NPP/NPP

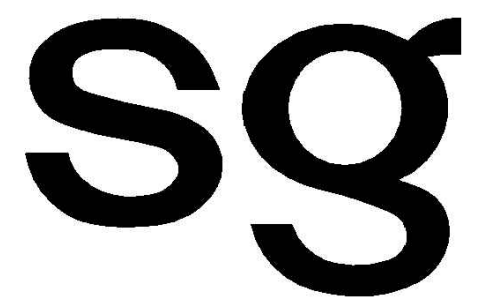

sweetgreen

3101 W. EXPOSITION BLVD.  
LOS ANGELES, CALIFORNIA 90018

THESE DRAWINGS & SPECIFICATIONS ARE CONFIDENTIAL AND SHALL REMAIN THE SOLE PROPERTY OF SWEETGREEN CORPORATION. THEY SHALL NOT BE REPRODUCED IN WHOLE OR IN PART, SHARED WITH THIRD PARTIES OR USED IN ANY MANNER ON OTHER PROJECTS OR EXTENSIONS TO THIS PROJECT WITHOUT THE PRIOR WRITTEN CONSENT OF SWEETGREEN CORPORATION. THESE DRAWINGS & SPECIFICATIONS ARE INTENDED TO EXPRESS DESIGN INTENT FOR A PROTOTYPICAL SWEETGREEN STORE (WHICH IS SUBJECT TO CHANGE AT ANY TIME) AND MAY NOT REFLECT ACTUAL SITE CONDITIONS. NEITHER PARTY SHALL HAVE ANY OBLIGATION OR LIABILITY TO THE OTHER (EXCEPT AS STATED ABOVE) UNTIL A WRITTEN AGREEMENT IS FULLY EXECUTED.

ARCHITECT OF RECORD:



ARCHITECTS  
FOOD + HOSPITALITY

FIRM REGISTRATION NO. BR 3045

STAMP:

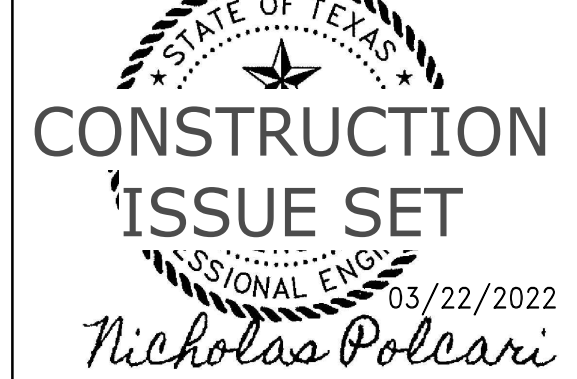

PROJECT INFORMATION:  
**LAKELWOOD**  
PROJECT INFORMATION:  
**6400 GASTON AVE.  
DALLAS, TX 75214**

DRAWN BY: MB  
CHECKED BY: ST  
PROJECT MANAGER: ST  
SG DESIGN MANAGER: KP  
SG CONSTR. MANAGER: JB  
PROJECT NO: 111020  
TEMPLATE VERSION: 04/30/2021

REVISIONS  
REV. DATE DESCRIPTION  
  
RECEIVED BY D4 CONSTRUCTION  
DATE: 03/24/2022

MECHANICAL SCHEDULES  
**M200**

James F. Turner  
Engineers, L.P.  
Consulting Engineers  
8540 Meadow Rd., Suite 160  
Dallas, Texas 75247  
TEL: 214-750-2900 Job #: 1113  
TX REGISTRATION # 32249

DRAWN/DESIGN CAD/ZBS DC/APP/NPP/NPP

GENERAL MECHANICAL NOTES:

- 1. ALL WORK SHALL BE ARRANGED IN A NEAT, WELL ORGANIZED MANNER. ALL WORK SHALL BE PARALLEL AND PERPENDICULAR TO THE PRIMARY LINES OF THE BUILDING. LOCATE ALL OPERATING AND CONTROL EQUIPMENT PROPERLY TO PROVIDE CODE AND/OR MANUFACTURERS CLEARANCES.
- 2. ALL WORK SHALL BE IN STRICT ACCORDANCE WITH ALL APPLICABLE PORTIONS OF ALL NATIONAL, STATE, AND LOCAL CODES AND STANDARDS. WHERE THE CONTRACT DOCUMENTS ARE IN EXCESS OF CODE REQUIREMENTS, THE CONTRACT DOCUMENTS SHALL GOVERN. IN THE EVENT OF A CONFLICT BETWEEN THE CONTRACT DOCUMENTS AND APPLICABLE CODES, THE LATTER SHALL GOVERN.
- 3. GC SHALL ENSURE THAT ALL LIGHTS, SPRINKLER HEADS, DIFFUSERS AND OTHER CEILING DEVICES ARE CENTERED IN CEILING TILES AND IN BETWEEN LIGHT FIXTURES.
- 4. ALL DUCT SIZES ARE CLEAR INSIDE DIMENSIONS.
- 5. ALL DUCTWORK TO BE EXTERNALLY INSULATED PER SPECIFICATIONS UNLESS NOTED OTHERWISE ON THE PLANS.
- 6. PROVIDE INSULATION BLANKETS AT ALL DIFFUSERS.
- 7. ALL EXPOSED DUCTWORK SHALL BE SUPPORTED BY ALL-THREAD ROD, SHALL BE INTERNALLY LINED AND SHALL BE PAINTED PER OWNER REQUIREMENTS.
- 8. FURNISH AND INSTALL ALL ITEMS, INCLUDING EVERY ARTICLE, DEVICE OR ACCESSORY REASONABLY NECESSARY TO FACILITATE EACH SYSTEMS' FUNCTIONING AS INDICATED BY THE DESIGN AND THE EQUIPMENT SPECIFIED. ELEMENTS OF THE WORK SHALL INCLUDE, BUT ARE NOT LIMITED TO MATERIALS, LABOR, SUPERVISION, SUPPLIES, EQUIPMENT, TRANSPORTATION, HOISTING/RIGGING, STORAGE, UTILITIES AND ALL REQUIRED PERMITS AND LICENSES.
- 9. UNIT LOCATIONS SHOWN ON PLAN ARE APPROXIMATE. COORDINATE EXACT LOCATION WITH STRUCTURAL PRIOR TO ROUGH-IN.
- 10. CONTRACTOR SHALL COORDINATE ALL DUCTWORK SIZES AND ROUTING WITH STRUCTURE AND OTHER DISCIPLINES PRIOR TO PURCHASING, CONSTRUCTING, OR INSTALLING ANY DUCTWORK. CONTRACTOR SHALL PROVIDE DUCTWORK SHOP DRAWINGS TO ENGINEER/ARCHITECT FOR APPROVAL PRIOR TO CONSTRUCTION. UNLESS SHOP DRAWINGS ARE SUBMITTED, CONTRACTOR ASSUMES ALL RESPONSIBILITY AND COST FOR ANY NECESSARY REWORK.
- 11. ALL BRANCH DUCTS ARE TO BE THE SAME SIZE AS DIFFUSER NECK UNLESS OTHERWISE NOTED. SEE DIFFUSERS RUNOUT SIZING CHART.
- 12. MAINTAIN ALL OUTSIDE AIR INTAKE OPENINGS MINIMUM 10'-0" FROM ALL MECHANICAL VENTS, PLUMBING VENTS, AND EXHAUST FANS.
- 13. PROVIDE BALANCING DAMPERS AT ALL SUPPLY AIR RUNOUTS.
- 14. ALL DUCTWORK SHALL BE CONSTRUCTED, SEALED AND SUPPORTED PER LATEST SMACNA AND ASHRAE RECOMMENDATIONS.
- 15. PROVIDE ALL MECHANICAL EQUIPMENT WITH NEW LAMINATED IDENTIFICATION TAGS. LABEL TAGS AS SHOWN ON PLAN INCLUDING AREA SERVED.
- 16. ALL GAS FIRED EQUIPMENT TO BE U.L. LISTED AND A.S.A. APPROVED.
- 17. ALL EQUIPMENT SHALL BE ANCHORED TO THE BUILDING STRUCTURE.
- 18. FLEX DUCT ALLOWED ONLY IN SUPPLY DUCTWORK IN AREAS WITH ACCESSIBLE CEILING AND ONLY IN THE LAST 6 FEET OF RUNOUTS. NO FLEX DUCTWORK ALLOWED IN RETURN AIR DUCTWORK.
- 19. REFER TO PLUMBING PLANS FOR CONDENSATE ROUTING.
- 20. EXCEPT AS REQUIRED BY IMC SECTIONS 602.2.1.1 THROUGH 602.2.1.6, MATERIALS WITHIN PLENUMS SHALL BE NONCOMBUSTIBLE OR SHALL HAVE A FLAME SPREAD INDEX OF NOT MORE THAN 25 AND A SMOKE DEVELOPED INDEX OF NOT MORE THAN 50 WHEN TESTED IN ACCORDANCE WITH ASTM-E-84 OR UL-723.
- 21. PROVIDE SLEEVES AND FLASHINGS REQUIRED FOR PIPING AND DUCTWORK PENETRATIONS. PROVIDE ESCUTCHEON PLATES FOR ALL PIPING PENETRATING FINISHED WALLS AND CEILING.
- 22. FIELD VERIFICATION OF EXISTING CONDITIONS SHALL BE THE RESPONSIBILITY OF THE CONTRACTOR. THE CONTRACTOR SHALL NOTIFY THE ARCHITECT/ENGINEER OF ANY DISCREPANCIES FOUND PRIOR TO SUBMISSION OF BID. THE CONTRACTOR SHALL TAKE NOTE THAT THE DRAWINGS ARE SCHEMATIC IN NATURE AND INDICATE THE APPROXIMATE LOCATIONS OF THE MECHANICAL AND PLUMBING SYSTEMS. LOCATE ALL ITEMS BY ON-THE-JOB MEASUREMENTS. COOPERATE WITH OTHER TRADES TO ENSURE PROPER FIT AND ACCESS TO ALL ITEMS.
- 23. PROVIDE FIRE AND/OR SMOKE DAMPERS IN ALL DUCT PENETRATIONS OF RATED WALLS WHETHER OR NOT SHOWN ON PLANS.
- 24. COORDINATE WITH ELECTRICAL TO PROVIDE POWER FOR ALL SMOKE DAMPERS WHETHER OR NOT SHOWN ON PLANS.
- 25. CONSIDERATION SHALL NOT BE GRANTED FOR MISUNDERSTANDING OF THE SCOPE OR AMOUNT OF WORK TO BE PERFORMED. TENDER OF A PROPOSAL CONVEYS FULL CONTRACTOR AGREEMENT OF THE ITEMS AND CONDITIONS SPECIFIED AND/OR INDICATED, SCHEDULED, OR IMPLIED ON THE CONTRACT DOCUMENTS, AND/OR REQUIRED BY THE NATURE OF THIS WORK.
- 26. THE GENERAL CONTRACTOR AND ALL SUBCONTRACTORS SHALL COORDINATE THE INSTALLATION OF DUCTWORK, PIPING, CONDUIT, CABLE, ETC., INSTALLATION WITH LIGHTING FIXTURES, SPECIAL CEILING CONSTRUCTION, AIR DISTRIBUTION EQUIPMENT AND THE STRUCTURE. PROVIDE ADDITIONAL RISES AND OFFSETS AS REQUIRED; IF, AFTER INSTALLED, NEW DUCTWORK, PIPING CONDUIT, OR CABLE IS FOUND TO BE IN CONFLICT WITH THE ARCHITECTURE, STRUCTURE, OR OTHER TRADE WORK, OR WHICH IS EITHER EXISTING OR SHOWN ON THE CONTRACT DOCUMENT, THE DUCTWORK, CONDUIT, OR CABLE SHALL BE RELOCATED WITHOUT ADDITIONAL COST TO THE OWNER.
- 27. THE CONTRACTOR SHALL PROTECT THE WORK, EQUIPMENT, AND MATERIALS FROM DAMAGE BY HIS WORK OR HIS PERSONNEL, AND SHALL CORRECT ALL DAMAGE THUS CAUSED WITHOUT ADDITIONAL COST TO THE OWNER. THE CONTRACTOR SHALL BE RESPONSIBLE FOR ALL WORK, MATERIALS, AND EQUIPMENT UNTIL FINAL ACCEPTANCE BY THE OWNER. PROTECT ALL WORK AGAINST THEFT, INJURY, OR DAMAGE AND CAREFULLY STORE MATERIAL AND EQUIPMENT RECEIVED ON SITE WHICH IS NOT IMMEDIATELY INSTALLED. THE CONTRACTOR SHALL CLOSE OPEN ENDS OF WORK WITH TEMPORARY COVERS OR PLUGS DURING CONSTRUCTION TO PREVENT THE ENTRY OF DUST, DIRT, AND OBSTRUCTING MATERIAL. THE CONTRACTOR SHALL PROTECT ALL EQUIPMENT AND MATERIALS FROM DAMAGE DUE TO WATER, SPRAY-ON FIREPROOFING CONSTRUCTION DEBRIS, ETC. IN A MANNER ACCEPTABLE TO THE ENGINEER AND/OR OWNER.

MECHANICAL SYMBOL LEGEND

SINGLE LINE SYMBOL	DESCRIPTION	DOUBLE LINE SYMBOL	SINGLE LINE SYMBOL	DESCRIPTION	DOUBLE LINE SYMBOL
[Symbol]	2'x2' SUPPLY AIR DIFFUSER 45° WITH FLEX CONN.	[Symbol]	[Symbol]	45° ELBOW	[Symbol]
[Symbol]	2'x2' SUPPLY AIR DIFFUSER 90° WITH FLEX CONN.	[Symbol]	[Symbol]	90° STRAIGHT ELBOW	[Symbol]
[Symbol]	2'x2' SUPPLY AIR DIFFUSER WITH OUT FLEX CONN.	[Symbol]	[Symbol]	90° CONICAL TEE OR SPIN IN TAP	[Symbol]
[Symbol]	ROUND NECK CLG. DIFFUSER 4-WAY DIRECTIONAL THROW	[Symbol]	[Symbol]	45° BRANCH	[Symbol]
[Symbol]	1'x1' SUPPLY AIR DIFFUSER 45°	[Symbol]	[Symbol]	SPLIT BRANCH TAKE-OFF WITH SQUARE ELBOW & SPLITTER DAMPER	[Symbol]
[Symbol]	1'x1' SUPPLY AIR DIFFUSER 90°	[Symbol]	[Symbol]	SPLIT BRANCH TAKE-OFF WITH RADIUS ELBOW & SPLITTER DAMPER	[Symbol]
[Symbol]	ROUND SUPPLY AIR DIFFUSER	[Symbol]	[Symbol]	SPLIT BRANCH TAKE-OFF WITH RADIUS HEEL & SPLITTER DAMPER	[Symbol]
[Symbol]	EXISTING 1'x1' CEILING OR EXHAUST RETURN AIR GRILLE OR REGISTER	[Symbol]	[Symbol]	BRANCH TAKE-OFF WITH AIR EXTRACTOR	[Symbol]
[Symbol]	1'x1' CEILING RETURN AIR OR EXHAUST GRILLE OR REGISTER	[Symbol]	[Symbol]	TEE WITH SPLITTER	[Symbol]
[Symbol]	EXISTING 2'x2' CEILING OR EXHAUST RETURN AIR GRILLE OR REGISTER	[Symbol]	[Symbol]	LINED DUCTWORK	[Symbol]
[Symbol]	2'x2' CEILING RETURN AIR OR EXHAUST GRILLE OR REGISTER	[Symbol]	[Symbol]	SIDEWALL SUPPLY GRILLE ON REGISTER WITH AIR EXTRACTOR	[Symbol]
[Symbol]	EXISTING 2'x4' CEILING OR EXHAUST RETURN AIR GRILLE OR REGISTER	[Symbol]	[Symbol]	TURNING VANE RECTANGULAR DUCT	[Symbol]
[Symbol]	2'x4' CEILING RETURN AIR OR EXHAUST GRILLE OR REGISTER	[Symbol]	[Symbol]	ROUND FLEXIBLE DUCT	[Symbol]
[Symbol]	EXISTING 1'x2' CEILING OR EXHAUST RETURN AIR GRILLE OR REGISTER	[Symbol]	[Symbol]	FLUE OR ROUND EXHAUST DUCT	[Symbol]
[Symbol]	1'x2' CEILING RETURN AIR OR EXHAUST GRILLE OR REGISTER	[Symbol]	[Symbol]	TAP	[Symbol]
[Symbol]	DOOR GRILLE	[Symbol]	[Symbol]	DAMPER	[Symbol]
[Symbol]	SUPPLY DUCT RISER	[Symbol]	[Symbol]	RETURN AIR OR TRANSFER AIR ARROW	[Symbol]
[Symbol]	RETURN, EXHAUST OR OUTSIDE AIR DUCT RISER	[Symbol]	[Symbol]	FLOW ARROW	[Symbol]
[Symbol]	OFFSET TO CHANGE ELEVATION (AT 30° WHEN POSSIBLE. ARROW SLOPES DN.)	[Symbol]	[Symbol]	EXISTING TO NEW CONNECTION	[Symbol]
[Symbol]	RECTANGULAR RADIUS ELBOW	[Symbol]	[Symbol]	FIRE AND SMOKE DAMPER	[Symbol]
[Symbol]	45° CONICAL TEE	[Symbol]	[Symbol]	SMOKE DAMPER	[Symbol]
[Symbol]	CONCENTRIC TRANSITION	[Symbol]	[Symbol]	FIRE DAMPER	[Symbol]
[Symbol]	SQUARE TO ROUND DUCT TRANSITION	[Symbol]	[Symbol]	CARBON MONOXIDE SENSOR	[Symbol]
[Symbol]	90° ELBOW DOWN (RECTANGULAR DUCT)	[Symbol]	[Symbol]	SMOKE DETECTOR	[Symbol]
[Symbol]	90° ELBOW UP (RECTANGULAR DUCT)	[Symbol]	[Symbol]	SENSOR	[Symbol]
[Symbol]	90° ELBOW DOWN (ROUND)	[Symbol]	[Symbol]	THERMOSTAT	[Symbol]
[Symbol]	90° ELBOW UP (ROUND)	[Symbol]	[Symbol]	HUMIDSTAT	[Symbol]
[Symbol]	OFFSET TO CHANGE ELEVATION (AT 30° WHEN POSSIBLE. ARROW SLOPES DN.)	[Symbol]	[Symbol]	ROOF MOUNTED EXHAUST FAN WITH EXHAUST DUCT	[Symbol]
[Symbol]	ROUND RADIUS ELBOW	[Symbol]	[Symbol]	BREAK	[Symbol]

ALL SYMBOLS ON THIS LIST ARE NOT NECESSARILY USED ON THIS JOB

VENTILATION CALCS

OUTSIDE AIR	
DINING	70 PEOPLE/1000 SQ. FT. X 1120 SQ. FT. = 79 PEOPLE 7.5 CFM/PERSON X 79 PEOPLE = 592 CFM 1120 SQ. FT. X 0.18 CFM/SQ. FT. = 202 CFM
OFFICE	5 CFM/PERSON X 1 PEOPLE = 5 CFM 43 SQ. FT. X 0.06 CFM/SQ. FT. = 3 CFM
CORRIDOR	168 SQ. FT. X 0.06 CFM/SQ. FT. = 10 CFM
TOTAL REQUIRED OUTDOOR AIR :	812 CFM
TOTAL SUPPLIED OUTDOOR AIR :	1300 CFM
EXHAUST AIR	
KITCHEN	850 SQ. FT. X 0.7 CFM/SQ. FT. = 595 CFM
RESTROOMS	2 FIXTURES X 70 CFM/FIXTURE = 140 CFM
TOTAL REQUIRED EXHAUST AIR :	735 CFM
TOTAL SUPPLIED EXHAUST AIR :	750 CFM

DIFFUSER LEGEND

GRILLE MARK FOR GRILLE SIZE SEE DIFFUSER DETAIL	A'/400	CUBIC FEET PER MINUTE
---	--------	-----------------------

EXHAUST FAN SCHEDULE

MARK	EF-1
TYPE	UPBLAST
CFM	750
EXTERNAL STATIC PRESSURE	0.5
ELECTRICAL DATA	
HORSEPOWER	1/6
VOLTS/PHASE	115/1
STARTER (SEE ELEC.)	-
RPM	1146
MANUFACTURER	COOK
MODEL No.	120ACRUB
LOCATION	ROOF/SERVICE

GENERAL NOTES:  
1. PROVIDE 12" HIGH FACTORY INSULATED CURB FOR EF-1.  
2. EF-1 TO RUN CONTINUOUSLY.

RTU SCHEDULE

MARK	RTU-1	RTU-2
NEW/EXISTING	EXISTING	EXISTING
TOTAL CFM	5000	3000
OUTSIDE AIR CFM	700	600
EXTERNAL STATIC PRESSURE (IN W.C.) APPROX.	0.75	0.75
HORSEPOWER	5.0	1.5
TOTAL CAPACITY (MBH) (APPROX. @ 80/67)	139.1	80.1
SENSIBLE (MBH) (APPROX. @ 80/67)	100.1	58.3
AMBIENT TEMPERATURE °F	105	105
HEATING DATA (MBH)		
INPUT	150	120
OUTPUT	122	96
VOLTS	208	208
PHASE	3	3
COMPRESSOR RLA - TOTAL - (EA)	44.8	25.9
COMPRESSOR LRA - TOTAL - (EA)	298	181
OUTDOOR FAN MOTOR - TOTAL - (EA)	6.4	4.0
MCA	67	42
MOCP (FUSE ONLY)	80	50
MANUFACTURER & MODEL No.	Lennox YHD150G3	YHC092F3
LOCATION	ROOF	ROOF
UNIT WEIGHT (APPROX.)	1971	915

GENERAL NOTES:  
1. RTUs TO BE PROVIDED BY LANDLORD. SHOWN HERE FOR COORDINATION ONLY.  
2. REBALANCE EXISTING RTU TO NEW OUTSIDE AIR SHOWN.

HOOD SCHEDULE

TAG	MANUFACTURER & MODEL #	AREA SERVED	WATTS	VOLTS/PHASE/HZ	WEIGHT	REMARKS
HD-1	RATIONAL ULTRAVENT PLUS 61/101E	COMBI-OVEN	450W	120/1/60	216 LBS	1-2

KEYED NOTES:  
1. VENTLESS HOOD MEETING UL 710B REQUIREMENTS ATTACHED TO TOP OF OVEN.  
2. HOOD PROVIDED BY KITCHEN EQUIPMENT SUPPLIER. SHOWN HERE FOR COORDINATION PURPOSES ONLY. REFER TO FOOD SERVICE EQUIPMENT SUPPLIER ITEM #K560.

AIR CURTAIN SCHEDULE

TAG	MANUFACTURER & MODEL #	LENGTH (IN)	AIRFLOW	FAN QUANTITY	MOTOR HP	WEIGHT (LBS)	VOLTS	PH	NOTES
AC-1	BERNER MAX1048A	48"	1381 CFM	1	1/5	48	120	1	1-2

KEYED NOTES:  
1. INTERLOCK WITH DOOR SWITCH.  
2. MOUNT UNIT PER MANUFACTURERS RECOMMENDATIONS.

AIR DEVICE SCHEDULE

MARK	SERVICE	TYPE	SIZE		BALANCING DAMPER	MFR.	MODEL	NOTES
			NECK	FACE				
A	SUPPLY	CEILING	SEE DETAIL	24x24	YES	TITUS	PAS-AA	1,2,3,4,5,6
B	RETURN	CEILING	SEE PLANS	24x24	YES	TITUS	8F	1,2,3,4,6
C	SUPPLY	CEILING	SEE DETAIL	12x12	YES	TITUS	OMNI-AA	1,2,3,4,6
D	EXHAUST	CEILING	SEE PLANS	12x12 U.N.O.	YES	TITUS	PAR-AA	1,2,3,4,6
E	SUPPLY	SIDEWALL	SEE DETAIL	4" LENGTH (2) 2" SLOT 12" INLET	YES	TITUS	FL-20	2,3,4,6
F	SUPPLY	SIDEWALL	SEE DETAIL	SEE PLANS	YES	TITUS	300FL	2,3,4,6
G	SUPPLY	CEILING	SEE DETAIL	24x24	YES	TITUS	TMSA	2,3,4,6

KEYED NOTES:  
1. ALL GRILLES IN TOILET ROOM AND KITCHEN AREAS TO BE ALUMINUM. ALL OTHERS STEEL UNLESS NOTED OTHERWISE.  
2. ALL AIR DEVICE COLORS TO BE SELECTED BY ARCHITECT.  
3. TRIM TO BE PREFINISHED OR PAINTED TO MATCH ADJACENT EXTERIOR AND INTERIOR WALL FINISH.  
4. CONTRACTOR IS RESPONSIBLE TO PROVIDE THE AIR DEVICE FRAME AND MOUNTING SYSTEM TO MATCH THE ARCHITECT CEILING TYPES. SEE ARCHITECTURAL DRAWINGS FOR COORDINATION.  
5. DISCHARGE PATTERN SHOULD BE ADJUSTED TO VERTICAL.  
6. ENSURE ALL BALANCING DAMPERS ARE ACCESSIBLE. PLACE DAMPER ABOVE CEILING GRID WHERE POSSIBLE, AND PROVIDE ACCESS PANEL FOR DAMPERS LOCATED ABOVE GYP. CEILINGS.

**SECTION 15000 – MECHANICAL SPECIFICATIONS GENERAL**

1. GENERAL CONDITIONS:
  - a. CONFORM TO APPLICABLE PROVISIONS OF THE GENERAL CONDITIONS, SUPPLEMENTARY CONDITIONS, AND THE LOCAL REQUIREMENTS.
  - b. DEFINITIONS: FURNISH MEANS TO SUPPLY AND DELIVER TO PROJECT SITE, READY FOR INSTALLATION. INSTALL MEANS TO PLACE IN POSITION AND MAKE CONNECTIONS FOR SERVICE OR USE. PROVIDE MEANS TO FURNISH AND INSTALL, COMPLETE AND READY FOR INTENDED USE.
2. SCOPE OF WORK:
  - a. PROVIDE ALL LABOR, EQUIPMENT, MATERIALS, TOOLS, ERECTION, HOISTING, AND INCIDENTALS REQUIRED TO PROVIDE HEATING, VENTILATION, GREASE EXHAUST, AND AIR CONDITIONING SYSTEMS.
  - b. PROVIDE EQUIPMENT INDICATED ON THE DRAWINGS, AND AS REQUIRED FOR A COMPLETE FUNCTIONING SYSTEM.
3. RULES AND REGULATIONS:
  - a. ALL WORK SHALL COMPLY WITH STATE AND LOCAL CODE REQUIREMENTS AS APPROVED AND AMENDED BY THE GOVERNING CITY. PURCHASE ALL PERMITS ASSOCIATED WITH THE WORK. OBTAIN ALL INSPECTIONS REQUIRED BY CODE.
  - b. WHERE THE STANDARDS OF THE DRAWINGS AND SPECIFICATIONS FOR MATERIALS AND/OR WORKMANSHIP ARE HIGHER THAN THE REQUIREMENTS CITED ABOVE, THE DRAWINGS AND SPECIFICATIONS SHALL TAKE PRECEDENCE.
4. WARRANTY:
  - a. PROVIDE LABOR AND MATERIALS TO REPAIR OR REPLACE DEFECTIVE PARTS AND MATERIALS AS REQUIRED FOR ONE YEAR AFTER OWNER ACCEPTANCE OF THE COMPLETED PROJECT. PROVIDE A SEPARATE LINE ITEM DEDUCT AMOUNT ON THE PROPOSAL FORM TO DELETE WARRANTY SERVICE, AT THE OWNER'S OPTION.
5. COORDINATION:
  - a. COORDINATE WITH THE WORK OF OTHER SECTIONS. EQUIPMENT FURNISHED BY OTHERS, REQUIREMENTS OF THE OWNER, AND WITH THE CONSTRAINTS OF THE EXISTING CONDITIONS OF THE PROJECT SITE.
  - b. CONTRACTOR SHALL EXECUTE WORK SO THAT PROGRESS WILL HARMONIZE WITH THAT OF THE OTHER TRADES, AND SO THAT ALL WORK MAY PROCEED AS EXPEDITIOUSLY AS POSSIBLE.
  - c. TO THE FULLEST EXTENT POSSIBLE, THE WORK UNDER THIS CONTRACT HAS BEEN INDICATED ON THE DRAWINGS IN SUCH POSITIONS AS TO SUIT AND ACCOMMODATE THE WORK OF OTHER TRADES, BUT THE WORK AS INDICATED IS LARGELY DIAGRAMMATIC AND THE FINAL POSITIONS OF ALL EQUIPMENT AND MATERIALS CANNOT BE INDICATED. THEREFORE, THE CONTRACTOR IS DIRECTLY RESPONSIBLE FOR THE CORRECT PLACEMENT OF WORK AND THE PROPER LOCATION AND CONNECTION OF WORK IN RELATION TO WORK OF OTHER TRADES.
  6. LOCATION AND SPACE REQUIREMENTS
    - a. VERIFY SPACES, DIMENSIONS, LOCATIONS, AND CONDITIONS REQUIRED FOR INSTALLATION OF ALL HVAC AND RELATED WORK.
    - b. OBTAIN NECESSARY ROUGH-IN DATA AND DIMENSIONS OF FIXTURES, EQUIPMENT, TENANT FURNISHED EQUIPMENT, OWNER FURNISHED EQUIPMENT, AND EQUIPMENT FURNISHED UNDER OTHER SECTIONS.
    - c. NO EXPOSED DUCTS WILL BE PERMITTED TO SHOW ON INTERIOR OF BUILDING UNLESS OFFSET WORK AS REQUIRED OCCUR, EXPOSED PORTION SHALL BE FURRED AND PLASTERED, OR CASED WHEN NOT ADJACENT TO THE WALL.
    - d. MAINTAIN SUFFICIENT CLEARANCE AND ACCESSIBILITY. INTERFERENCES BETWEEN WORK OF VARIOUS TRADES WILL BE RESOLVED BY THE ARCHITECT AND OWNER IN CONSULTATION WITH THE ENGINEER. RELOCATE OR OFFSET WORK AS REQUIRED TO ACCOMMODATE WORK OF OTHER TRADES. MAINTAIN CEILING HEIGHTS AND AVOID EXCESSIVE FURRING REQUIREMENTS.
    - e. IF NOT PRECISELY LOCATED ON DRAWINGS, OBTAIN LOCATION OF FIXTURES, EQUIPMENT, AND APPLIANCES, FROM ARCHITECT AND FOOD SERVICE EQUIPMENT SUPPLIER. NO DEVIATIONS WILL BE ALLOWED.
  7. MEASUREMENTS:
    - a. ALL DIMENSIONS OF WORK OF OTHER TRADES WHICH REQUIRE VERIFICATION SHALL BE VERIFIED FROM SHOP DRAWINGS OF SUCH WORK OR FROM ACTUAL MEASUREMENTS AT BUILDING, WHICHEVER IS THE MOST ACCURATE AND PRACTICAL IN THE JUDGMENT OF THE CONTRACTOR, WHO SHALL BE RESPONSIBLE FOR THE ACCURACY OF SUCH MEASUREMENTS.
  8. GENERAL MATERIALS:
    - a. ALL MATERIALS SHALL CONFORM TO APPLICABLE ASHRAE AND SMACNA STANDARDS.
    - b. BRANDS OF MATERIALS MENTIONED ARE USED AS A STANDARD AND REQUESTS FOR SUBSTITUTIONS WILL BE CONSIDERED WHEN SUBMITTED TO THE ENGINEER IN ACCORDANCE WITH THE PROVISIONS SET FORTH IN THE SUPPLEMENTARY GENERAL CONDITIONS.
    - c. APPROVED EQUAL REFERS TO MATERIALS WHICH, IN THE OPINION OF THE ENGINEER AND EQUAL IN ALL RESPECTS TO MATERIAL OR METHOD INDICATED ON DRAWINGS OR AS SPECIFIED. ENGINEER IS NOT REQUIRED TO PROVE THAT A SUBSTITUTE MATERIAL IS NOT EQUAL TO SPECIFIED MATERIAL. CONTRACTOR SHALL SUBMIT IN WRITING TO ENGINEER EVIDENCE SUPPORTING HIS CONTENTION THAT SUBSTITUTED MATERIAL IS EQUAL TO MATERIAL SHOWN ON DRAWINGS OR SPECIFIED. ENGINEER RESERVES RIGHT TO REJECT MATERIALS AND WORKMANSHIP, EITHER BEFORE OR AFTER INSTALLATION, THAT ARE NOT SHOWN ON DRAWINGS OR SPECIFICATIONS, OR SUBSTITUTIONS THAT HAVE NOT BEEN APPROVED BY ENGINEER IN WRITING.
  9. DUCTWORK:
    - a. DUCT DIMENSIONS: UNLESS OTHERWISE NOTED, DUCT DIMENSIONS ON THE DRAWINGS ARE INSIDE CLEAR DIMENSIONS.
    - b. SHEET METAL DUCTWORK: PROVIDE SHEET METAL DUCTWORK FABRICATED AND INSTALLED IN ACCORDANCE WITH ASHRAE AND SMACNA STANDARDS, FOR 1" W.G. PRESSURE CLASS, SEAL CLASS "A". SHEET METAL SHALL BE GALVANIZED SHEET STEEL OF LOCK FORMING QUALITY, ASTM-A525. ALL ANGLE IRON USED FOR SUPPORT SHALL BE GALVANIZED. CONNECTIONS TO WALLS OR FLOOR SHALL BE AIR TIGHT WITH ANGLE IRON AND CAULKING. SEAL ALL DUCT SEAMS, TRANSVERSE, AND LONGITUDINAL, AIR TIGHT. PROVIDE TURNING VANES AT ALL 90-DEGREE ELBOWS.
    - c. ROUND SHEET METAL DUCT: PROVIDE SPIRAL SEAM (ALL SIZES) OR SNAP LOCK (DUCT SIZES UP TO 10") GALVANIZED STEEL COMPLYING WITH SMACNA STANDARDS. SPIRAL SEAM DUCTWORK SHALL HAVE SMACNA SEAL TYPE REINFORCED.
    - d. FLEXIBLE DUCT: PROVIDE FACTORY ASSEMBLED CLASS 1 AIR DUCT (UL 181) WITH 1" THICK 1 PCF FIBERGLASS INSULATION AND REINFORCED OUTER PROTECTIVE COVER/VAPOR BARRIER. FLEXIBLE DUCT SHALL MEET NFPA 90A WITH FLAME SPREAD UNDER 25. SMOKE DEVELOPED UNDER 50, AND SHALL BE RATED FOR MINIMUM 2" W.G. PRESSURE AND 0 TO 250-DEGREE F TEMPERATURE. USE TWIST-LOCK CONICAL TAP COLLARS AT CONNECTIONS INTO SHEET METAL DUCTWORK. MAXIMUM EXTENDED LENGTH OF FLEXIBLE DUCT SHALL NOT EXCEED 6 FEET.
    - e. EXPOSED DUCTWORK: EXPOSED DUCTWORK SHALL BE CLEANED OF DEBRIS AND OIL, THEN WIPED DOWN WITH VINEGAR OR OTHER SURFACE PREPARING CHEMICAL TO PREPARE DUCT FOR PAINT.
    - f. DUCT SEALANT: PROVIDE POLYMERIC RUBBER TYPE SEALANT FOR USE ON BOTH INTERIOR LOCATED DUCTWORK AND DUCTWORK EXPOSED TO OUTDOOR CONDITIONS. SEALER SHALL HAVE HIGH BONDING STRENGTH FOR SURE, FIRST TIME SEALING OF JOINTS IN LOW, MEDIUM, AND HIGH PRESSURE DUCT SYSTEMS.
    - g. DUCT TURNING VANES: PROVIDE FABRICATED TURNING VANES AND VANE RUNNERS, CONSTRUCTED IN ACCORDANCE WITH SMACNA "HVAC DUCT CONSTRUCTION STANDARDS". PROVIDE TURNING VANES CONSTRUCTED OF CURVED BLADES SUPPORTED WITH BARS PERPENDICULAR TO BLADES, AND SET INTO SIDE STRIPS SUITABLE FOR MOUNTING IN DUCTWORK. FOLLOW SMACNA GUIDELINES FOR SPACING SUPPORT, AND CONSTRUCTION. ALL BLADES SHALL BE DOUBLE THICKNESS AIRFOIL TYPE.
  10. DUCTWORK ACCESSORIES:
    - a. FLEXIBLE DUCT CONNECTORS: PROVIDE UL LABELED 30 OUNCE NEOPRENE COATED FIBERGLASS FABRIC DUCT CONNECTORS.
    - b. DUCT ACCESS DOORS: PROVIDE HINGED ACCESS DOORS IN DUCTWORK WHERE REQUIRED FOR ACCESS TO EQUIPMENT. PROVIDE INSULATED ACCESS DOORS FOR INSULATED DUCTWORK. CONSTRUCT OF SAME OR THICKER GAUGE SHEET METAL AS DUCT IN WHICH IT IS INSTALLED. PROVIDE FLUSH FRAMES FOR UNINSULATED DUCTS, AND EXTENDED FRAMES FOR EXTERNALLY INSULATED DUCTS. PROVIDE CONTINUOUS HINGE ON ONE SIDE, WITH ONE HANDLE-TYPE LATCH FOR ACCESS DOORS 12" HIGH AND SMALLER, AND TWO HANDLE-TYPE LATCHES FOR LARGER ACCESS DOORS.
    - c. ROUND VOLUME DAMPERS: PROVIDE MINIMUM 20 GAUGE GALVANIZED STEEL FRAME AND BLADES. MINIMUM 3/8" SQUARE STEEL AXLE. MOLDED SYNTHETIC BEARINGS, WITH LOCKING POSITION REGULATOR. REGULATOR SHALL BE POSITIONED WITH SHEET METAL BRACKET BEYOND DUCT COVERING. WHERE POSITIONING REGULATOR IS NOT ACCESSIBLE, PROVIDE COUPLING AND EXTENSION ROD WITH REGULATOR FOR CEILING OR WALL INSTALLATION, AS REQUIRED.
    - d. GALVANIZED STEEL FRAME AND BLADES. MINIMUM 3/8" SQUARE STEEL AXLE. MOLDED SYNTHETIC BEARINGS, WITH LOCKING POSITION REGULATOR. REGULATOR SHALL BE POSITIONED WITH SHEET METAL BRACKET BEYOND DUCT COVERING. WHERE POSITIONING REGULATOR IS NOT ACCESSIBLE, PROVIDE COUPLING AND EXTENSION ROD WITH REGULATOR FOR CEILING OR WALL INSTALLATION, AS REQUIRED.
    - e. GALVANIZED STEEL CHANNEL FRAME, 16 GAUGE GALVANIZED STEEL BLADES, MINIMUM 1/2" HEXAGONAL AXLE, BOLDED SYNTHETIC BEARINGS, WITH 3/8" SQUARE PLATED STEEL CONTROL SHAFT. LINKAGES SHALL BE CONCEALED IN THE FRAME. OPERATING SHAFT SHALL EXTEND BEYOND FRAME AND DUCT TO A LOCKING QUADRANT WITH ADJUSTABLE LEVER. MAXIMUM BLADE WIDTH SHALL NOT EXCEED 6".
    - f. FIRE DAMPERS/SMOKE DAMPERS:
      1. CURTAIN FIRE DAMPERS: PROVIDE CURTAIN TYPE FIRE DAMPERS, SUITABLE FOR VERTICAL OR HORIZONTAL INSTALLATION AS REQUIRED FOR THE LOCATION SHOWN. CURTAIN FIRE DAMPERS SHALL HAVE MINIMUM 24 GAUGE GALVANIZED STEEL BLADES, COMPLETELY OUT OF THE AIR STREAM. CURTAIN FIRE DAMPERS SHALL CONFORM TO UL STANDARD 555, WHICH INCLUDES TESTING TO CLOSE UNDER DYNAMIC AIRFLOW CONDITIONS, AND SHALL BE UL LABELED AS A DYNAMIC RATED FIRE DAMPER. DAMPERS SHALL BE 1-1/2" OR 3 HOUR RATED AS REQUIRED BY LOCATION, AND SHALL HAVE 212-DEGREE F FUSIBLE LINK.
      2. CEILING FIRE DAMPERS: PROVIDE CEILING FIRE DAMPERS CONSTRUCTED AND TESTED IN ACCORDANCE WITH CURRENT EDITION OF UL STANDARD 555C. CEILING FIRE DAMPERS SHALL HAVE MINIMUM 20 GAUGE GALVANIZED STEEL BLADES, WITH UL CLASSIFIED INSULATION, AND MINIMUM 20 GAUGE GALVANIZED STEEL FRAMES. CEILING FIRE DAMPERS SHALL HAVE A 212-DEGREE F FUSIBLE LINK. PROVIDE DIFFUSER RADIATION SHIELDS CONSTRUCTED OF REFRACTORY CERAMIC FIBER AS APPLICABLE.
      3. COMBINATION FIRE/SMOKE DAMPERS: PROVIDE COMBINATION FIRE/SMOKE DAMPERS CONSTRUCTED AND TESTED IN ACCORDANCE WITH CURRENT EDITION OF UL STANDARD 555S. COMBINATION FIRE/SMOKE DAMPERS SHALL HAVE GALVANIZED STEEL AIRFOIL BLADES WITH SILICONE RUBBER BLADE SEALS AND FLEXIBLE STAINLESS STEEL JAMB SEALS. FRAMES SHALL BE MINIMUM 16 GAUGE GALVANIZED STEEL. AXLES SHALL BE MINIMUM 1/2" PLATED STEEL. PROVIDE 212-DEGREE F FUSIBLE LINK. PROVIDE OFFSET BLADE CONFIGURATION. LINKAGES SHALL BE CONCEALED IN THE FRAME. LEAKAGE RATING SHALL BE UL 555S CLASS 1 (4 CFM/ SF AT 1.0" W.G.). PROVIDE FACTORY INSTALLED ACTUATOR, LOCATED OUT OF THE AIR STREAM. COMBINATION FIRE/SMOKE DAMPERS SHALL BE POWERED OPEN, SPRING CLOSED.
      4. PROVIDE APPROVED FIRE DAMPERS AT ALL LOCATIONS INDICATED ON THE PLANS AND/OR REQUIRED BY BUILDING CODE.
      5. FIRE DAMPERS AND FUSIBLE LINKS SHALL BE ACCESSIBLE THROUGH ACCESS DOORS OR PANELS IN DUCTS AND ACCESS PANELS IN THE BUILDING STRUCTURE OR CEILING.
      6. FIRE DAMPERS FURNISHED AS AN INTEGRAL PART OF DIFFUSERS OR GRILLES SHALL BE ACCESSIBLE BY MEANS OF REMOVABLE GRILLE OR DIFFUSER FACE.
    7. DUCT INSULATION:
      - a. BLANKET TYPE DUCT INSULATION: PROVIDE MINIMUM 1-1/2" THICK BLANKET TYPE FIBERGLASS INSULATION COMPLYING WITH ASTM C-553, TYPE II, WITH FACTORY APPLIED KRAFT BONDED TO ALUMINUM FOIL, REINFORCED WITH FIBERGLASS VAPOR BARRIER/JACKET. JACKET SHALL CONFORM TO ASTM C-1136, TYPE II.
      - b. CONCEALED CONDITIONED SUPPLY AND RETURN AIR DUCTS SHALL BE INSULATED WITH BLANKET TYPE DUCT INSULATION, INSTALLED IN ACCORDANCE WITH INSULATION MANUFACTURER'S INSTALLATION INSTRUCTIONS.
      - c. CONDITIONED SUPPLY AIR AND RETURN AIR DUCTS AND PLENUMS EXPOSED TO VIEW OR WHERE REQUIRED FOR ACOUSTICAL PURPOSES SHALL BE LINED WITH DUCT LINER. INSTALL DUCT LINER IN ACCORDANCE WITH LINER MANUFACTURER'S INSTALLATION INSTRUCTIONS.
    8. CONTROL SYSTEMS:
      - a. PROVIDE COMPLETE CONTROL SYSTEMS, INCLUDING ALL INSTRUMENTS, CONTROLS, THERMOSTATS, TEMPERATURE SENSORS, LOW VOLTAGE WIRING, TRANSFORMERS, AND ALL NECESSARY APPURTENANCES. LOW VOLTAGE WIRING SHALL BE INSTALLED IN CONDUIT IN ACCORDANCE WITH ELECTRICAL SPECIFICATIONS.
  11. TESTING, ADJUSTING, AND BALANCING:
    - a. TEST, ADJUST, AND BALANCE ALL MECHANICAL SYSTEMS AND EQUIPMENT TO ENSURE PROPER BALANCE AND OPERATION. PERFORM TESTS IN ACCORDANCE WITH NEBB OR AABC AND ASHRAE STANDARDS. ELIMINATE NOISE AND VIBRATION, AND ENSURE PROPER FUNCTION OF CONTROLS. SUBMIT COMPLETED CERTIFIED TEST AND BALANCE REPORT TO OWNER'S REPRESENTATIVE. BALANCING CONTRACTOR SHALL BE AN INDEPENDENT NEBB OR AABC CERTIFIED TEST AND BALANCE CONTRACTOR. BALANCE ALL SYSTEMS TO WITHIN 5% OF AIR FLOWS INDICATED ON THE DRAWINGS, AND REPORT ALL DISCREPANCIES TO HVAC INSTALLER FOR CORRECTION. MARK FINAL BALANCE POSITIONS ON DAMPERS WITH PERMANENT MARKER. FINAL STORE BALANCE SHALL BE POSITIVE WITH RESPECT TO OUTDOORS.
    - b. VIBRATION AND NOISE
      1. ELIMINATE VIBRATION AND NOISE FROM THE OPERATION OF FANS, MOTORS, AND EQUIPMENT TO THE EXTENT THAT THEY WILL NOT BE HEARD OUTSIDE OF THE ROOM IN WHICH INSTALLED. ADJUSTMENTS AND CHANGES TO PRODUCE SATISFACTORY QUIETNESS TO BE MADE WITHOUT EXPENSE TO OWNER.
    - c. OPERATING AND MAINTENANCE MANUALS
      1. PROVIDE COMPLETE OPERATIONS AND MAINTENANCE MANUALS FOR ALL MECHANICAL EQUIPMENT INSTALLED ON PROJECT. INCLUDE INDEX OF EQUIPMENT, DIRECTORY INCLUDING SUPPLIER TELEPHONE NUMBERS, AND LIST OF RECOMMENDED SPARE PARTS. MANUALS SHALL BE FURNISHED IN "D-RING" BINDERS, CLEARLY LABELED "OPERATION AND MAINTENANCE MANUAL FOR CHECK CASHERS". PROVIDE 2 COPIES OF EACH MANUAL. PROVIDE INSTRUCTIONS BY QUALIFIED TECHNICIAN TO OWNER'S REPRESENTATIVE.
      2. CLEANING:
        - a. MACHINERY AND APPARATUS. THOROUGHLY CLEAN CEMENT AND PLASTER AND OTHER MATERIALS. REMOVE GREASE AND OIL SPOTS WITH CLEANING SOLVENT. CAREFULLY WIPE SURFACES CLEAN.
        - b. EXPOSED METAL WORK: CAREFULLY CLEAN WITH STEEL BRUSH, REMOVING ALL RUST AND SOILED SPOTS, AND PROVIDE TOUCH-UP PAINT AS REQUIRED.
        - c. FINAL CLEANING: REMOVE ALL SCRAPS AND INSTALLATION-RELATED DEBRIS FROM AREA. LEAVE ENTIRE INSTALLATION AREA IN A NEAT, CLEAN, AND READY-TO-USE CONDITION.

**2015 IECC (INTERNATIONAL ENERGY CONSERVATION CODE) COMMISSIONING REQUIREMENTS**

PRIOR TO FINAL INSPECTION, MECHANICAL CONTRACTOR TO PROVIDE ENGINEER (AS A SUBMITTAL SENT THROUGH THE ARCHITECT/BUILDER) A SIGNED LETTER ON COMPANY LETTERHEAD STATING THAT ANY/ALL APPLICABLE ITEMS/SYSTEMS LISTED IN 2015 IECC SECTION C408.2 (AND ALL SUBHEADINGS) HAVE BEEN TESTED AND COMPLY WITH THE CODE. FOR REFERENCE:

C408.2 MECHANICAL SYSTEMS AND SERVICE WATER-HEATING SYSTEMS COMMISSIONING AND COMPLETION REQUIREMENTS. PRIOR TO THE FINAL MECHANICAL AND PLUMBING INSPECTIONS, THE REGISTERED DESIGN PROFESSIONAL OR APPROVED AGENCY SHALL PROVIDE EVIDENCE OF MECHANICAL SYSTEMS COMMISSIONING AND COMPLETION IN ACCORDANCE WITH THE PROVISIONS OF THIS SECTION.

CONSTRUCTION DOCUMENT NOTES SHALL CLEARLY INDICATE PROVISIONS FOR COMMISSIONING AND COMPLETION REQUIREMENTS IN ACCORDANCE WITH THIS SECTION AND ARE PERMITTED TO REFER TO SPECIFICATIONS FOR FURTHER REQUIREMENTS. COPIES OF ALL DOCUMENTATION SHALL BE GIVEN TO THE OWNER OR OWNER'S AUTHORIZED AGENT AND MADE AVAILABLE TO THE CODE OFFICIAL UPON REQUEST IN ACCORDANCE WITH SECTIONS C408.2.4 AND C408.2.5.

EXCEPTIONS: THE FOLLOWING SYSTEMS ARE EXEMPT:

1. MECHANICAL SYSTEMS AND SERVICE WATER HEATER SYSTEMS IN BUILDINGS WHERE THE TOTAL MECHANICAL EQUIPMENT CAPACITY IS LESS THAN 480,000 BTU/H (140.7 kW) COOLING CAPACITY AND 600,000 BTU/H (175.8 kW) COMBINED SERVICE WATER-HEATING AND SPACE-HEATING CAPACITY.
2. SYSTEMS INCLUDED IN SECTION C403.3 THAT SERVE INDIVIDUAL DWELLING UNITS AND SLEEPING UNITS.

C408.2.1 COMMISSIONING PLAN. A COMMISSIONING PLAN SHALL BE DEVELOPED BY A REGISTERED DESIGN PROFESSIONAL OR APPROVED AGENCY AND SHALL INCLUDE THE FOLLOWING ITEMS:

1. A NARRATIVE DESCRIPTION OF THE ACTIVITIES THAT WILL BE ACCOMPLISHED DURING EACH PHASE OF COMMISSIONING, INCLUDING THE PERSONNEL INTENDED TO ACCOMPLISH EACH OF THE ACTIVITIES.
2. A LISTING OF THE SPECIFIC EQUIPMENT, APPLIANCES OR SYSTEMS TO BE TESTED AND A DESCRIPTION OF THE TESTS TO BE PERFORMED.
3. FUNCTIONS TO BE TESTED INCLUDING, BUT NOT LIMITED TO, CALIBRATIONS AND ECONOMIZER CONTROLS.
4. CONDITIONS UNDER WHICH THE TEST WILL BE PERFORMED. TESTING SHALL AFFIRM WINTER AND SUMMER DESIGN CONDITIONS AND FULL OUTDOOR AIR CONDITIONS.
5. MEASURABLE CRITERIA FOR PERFORMANCE.

C408.2.2 SYSTEMS ADJUSTING AND BALANCING. HVAC SYSTEMS SHALL BE BALANCED IN ACCORDANCE WITH GENERALLY ACCEPTED ENGINEERING STANDARDS. AIR AND WATER FLOW RATES SHALL BE MEASURED AND ADJUSTED TO DELIVER FINAL FLOW RATES WITHIN THE TOLERANCES PROVIDED IN THE PRODUCT SPECIFICATIONS. TEST AND BALANCE ACTIVITIES SHALL INCLUDE AIR SYSTEM AND HYDRONIC SYSTEM BALANCING.

C408.2.2.1 AIR SYSTEMS BALANCING. EACH SUPPLY AIR OUTLET AND RETURN TERMINAL DEVICE SHALL BE EQUIPPED WITH MEANS FOR AIR BALANCING IN ACCORDANCE WITH THE REQUIREMENTS OF CHAPTER 6 OF THE INTERNATIONAL MECHANICAL CODE. DISCHARGE DAMPERS USED FOR AIR-SYSTEM BALANCING ARE PROHIBITED ON CONSTANT-VOLUME FANS AND VARIABLE-VOLUME FANS WITH MOTORS 10 HP (18.6 kW) AND LARGER. AIR SYSTEMS SHALL BE BALANCED IN A MANNER TO FIRST MINIMIZE THROTTLING LOSSES THEN, FOR FANS WITH SYSTEM POWER OF GREATER THAN 1 HP (0.746 kW), FAN SPEED SHALL BE ADJUSTED TO MEET DESIGN FLOW CONDITIONS.

EXCEPTION: FANS WITH FAN MOTORS OF 1 HP (0.74 kW) OR LESS ARE NOT REQUIRED TO BE PROVIDED WITH A MEANS FOR AIR BALANCING.

C408.2.2.2 HYDRONIC SYSTEMS BALANCING. INDIVIDUAL HYDRONIC HEATING AND COOLING COILS SHALL BE EQUIPPED WITH MEANS FOR BALANCING AND MEASURING FLOW. HYDRONIC SYSTEMS SHALL BE PROPORTIONATELY BALANCED IN A MANNER TO FIRST MINIMIZE THROTTLING LOSSES, THEN THE PUMP IMPELLER SHALL BE TRIMMED OR PUMP SPEED SHALL BE ADJUSTED TO MEET DESIGN FLOW CONDITIONS. EACH HYDRONIC SYSTEM SHALL HAVE EITHER THE CAPABILITY TO MEASURE PRESSURE ACROSS THE PUMP, OR TEST PORTS AT EACH SIDE OF EACH PUMP.

EXCEPTIONS: THE FOLLOWING EQUIPMENT IS NOT REQUIRED TO BE EQUIPPED WITH A MEANS FOR BALANCING OR MEASURING FLOW:

1. PUMPS WITH PUMP MOTORS OF 5 HP (3.7 kW) OR LESS.
  2. WHERE THROTTLING RESULTS IN NO GREATER THAN 5 PERCENT OF THE NAMEPLATE HORSEPOWER DRAW ABOVE THAT REQUIRED IF THE IMPELLER WERE TRIMMED.
- C408.2.3 FUNCTIONAL PERFORMANCE TESTING. FUNCTIONAL PERFORMANCE TESTING SPECIFIED IN SECTIONS C408.2.3.1 THROUGH C408.2.3.3 SHALL BE CONDUCTED.

C408.2.3.1 EQUIPMENT. EQUIPMENT FUNCTIONAL PERFORMANCE TESTING SHALL DEMONSTRATE THE INSTALLATION AND OPERATION OF COMPONENTS, SYSTEMS, AND SYSTEM-TO-SYSTEM INTERFACING RELATIONSHIPS IN ACCORDANCE WITH APPROVED PLANS AND SPECIFICATIONS SUCH THAT OPERATION, FUNCTION, AND MAINTENANCE SERVICEABILITY FOR EACH OF THE COMMISSIONED SYSTEMS IS CONFIRMED. TESTING SHALL INCLUDE ALL MODES AND SEQUENCE OF OPERATION, INCLUDING UNDER FULL-LOAD, PART-LOAD AND THE FOLLOWING EMERGENCY CONDITIONS:

1. ALL MODES AS DESCRIBED IN THE SEQUENCE OF OPERATION.
2. REDUNDANT OR AUTOMATIC BACK-UP MODE.
3. PERFORMANCE OF ALARMS.
4. MODE OF OPERATION UPON A LOSS OF POWER AND RESTORATION OF POWER.

EXCEPTION: UNITARY OR PACKAGED HVAC EQUIPMENT LISTED IN TABLES C403.2.3(1) THROUGH C403.2.3(3) THAT DO NOT REQUIRE SUPPLY AIR ECONOMIZERS.

C408.2.3.2 CONTROLS. HVAC AND SERVICE WATER-HEATING CONTROL SYSTEMS SHALL BE TESTED TO DOCUMENT THAT CONTROL DEVICES, COMPONENTS, EQUIPMENT AND SYSTEMS ARE CALIBRATED AND ADJUSTED AND OPERATE IN ACCORDANCE WITH APPROVED PLANS AND SPECIFICATIONS. SEQUENCES OF OPERATION SHALL BE FUNCTIONALLY TESTED TO DOCUMENT THEY OPERATE IN ACCORDANCE WITH APPROVED PLANS AND SPECIFICATIONS.

C408.2.3.3 ECONOMIZERS. AIR ECONOMIZERS SHALL UNDERGO A FUNCTIONAL TEST TO DETERMINE THAT THEY OPERATE IN ACCORDANCE WITH MANUFACTURER'S SPECIFICATIONS.

C408.2.4 PRELIMINARY COMMISSIONING REPORT. A PRELIMINARY REPORT OF COMMISSIONING TEST PROCEDURES AND RESULTS SHALL BE COMPLETED AND CERTIFIED BY THE REGISTERED DESIGN PROFESSIONAL OR APPROVED AGENCY AND PROVIDED TO THE BUILDING OWNER OR OWNER'S AUTHORIZED AGENT. THE REPORT SHALL BE ORGANIZED WITH MECHANICAL AND SERVICE HOT WATER FINDINGS IN SEPARATE SECTIONS TO ALLOW INDEPENDENT REVIEW. THE REPORT SHALL BE IDENTIFIED PRELIMINARY COMMISSIONING REPORT AND SHALL IDENTIFY:

1. ITEMIZATION OF DEFICIENCIES FOUND DURING TESTING REQUIRED BY THIS SECTION THAT HAVE NOT BEEN CORRECTED AT THE TIME OF REPORT PREPARATION.
2. DEFERRED TESTS THAT CANNOT BE PERFORMED AT THE TIME OF REPORT PREPARATION BECAUSE OF CLIMATIC CONDITIONS.
3. CLIMATIC CONDITIONS REQUIRED FOR PERFORMANCE OF THE DEFERRED TESTS.

C408.2.4.1 ACCEPTANCE OF REPORT. BUILDINGS, OR PORTIONS THEREOF, SHALL NOT BE CONSIDERED ACCEPTABLE FOR A FINAL INSPECTION PURSUANT TO SECTION C104.3 UNTIL THE CODE OFFICIAL HAS RECEIVED A LETTER OF TRANSMITTAL FROM THE BUILDING OWNER ACKNOWLEDGING THAT THE BUILDING OWNER OR OWNER'S AUTHORIZED AGENT HAS RECEIVED THE PRELIMINARY COMMISSIONING REPORT.

C408.2.4.2 COPY OF REPORT. THE CODE OFFICIAL SHALL BE PERMITTED TO REQUIRE THAT A COPY OF THE PRELIMINARY COMMISSIONING REPORT BE MADE AVAILABLE FOR REVIEW BY THE CODE OFFICIAL.

C408.2.5 DOCUMENTATION REQUIREMENTS. THE CONSTRUCTION DOCUMENTS SHALL SPECIFY THAT THE DOCUMENTS

DESCRIBED IN THIS SECTION BE PROVIDED TO THE BUILDING OWNER OR OWNER'S AUTHORIZED AGENT WITHIN 90 DAYS OF THE DATE OF RECEIPT OF THE CERTIFICATE OF OCCUPANCY.

C408.2.5.1 DRAWINGS. CONSTRUCTION DOCUMENTS SHALL INCLUDE THE LOCATION AND PERFORMANCE DATA ON EACH PIECE OF EQUIPMENT.

C408.2.5.2 MANUALS. AN OPERATING AND MAINTENANCE MANUAL SHALL BE PROVIDED AND INCLUDE ALL OF THE FOLLOWING:

1. SUBMITTAL DATA STATING EQUIPMENT SIZE AND SELECTED OPTIONS FOR EACH PIECE OF EQUIPMENT REQUIRING MAINTENANCE.
2. MANUFACTURER'S OPERATION MANUALS AND MAINTENANCE MANUALS FOR EACH PIECE OF EQUIPMENT REQUIRING MAINTENANCE, EXCEPT EQUIPMENT NOT FURNISHED AS PART OF THE PROJECT. REQUIRED ROUTINE MAINTENANCE ACTIONS SHALL BE CLEARLY IDENTIFIED.
3. NAME AND ADDRESS OF AT LEAST ONE SERVICE AGENCY.
4. HVAC AND SERVICE HOT WATER CONTROLS SYSTEM MAINTENANCE AND CALIBRATION INFORMATION, INCLUDING WIRING DIAGRAMS, SCHEMATICS AND CONTROL SEQUENCE DESCRIPTIONS, DESIRED OR FIELD-DETERMINED SET POINTS SHALL BE PERMANENTLY RECORDED ON CONTROL DRAWINGS AT CONTROL DEVICES OR, FOR DIGITAL CONTROL SYSTEMS, IN SYSTEM PROGRAMMING INSTRUCTIONS.
5. SUBMITTAL DATA INDICATING ALL SELECTED OPTIONS FOR EACH PIECE OF LIGHTING EQUIPMENT AND LIGHTING CONTROLS.
6. OPERATION AND MAINTENANCE MANUALS FOR EACH PIECE OF LIGHTING EQUIPMENT. REQUIRED ROUTINE MAINTENANCE ACTIONS, CLEANING AND RECOMMENDED RELAMPING SHALL BE CLEARLY IDENTIFIED.
7. A SCHEDULE FOR INSPECTING AND RECALIBRATING ALL LIGHTING CONTROLS.
8. A NARRATIVE OF HOW EACH SYSTEM IS INTENDED TO OPERATE, INCLUDING RECOMMENDED SET POINTS.

C408.2.5.3 SYSTEM BALANCING REPORT. A WRITTEN REPORT DESCRIBING THE ACTIVITIES AND MEASUREMENTS COMPLETED IN ACCORDANCE WITH SECTION C408.2.2.

C408.2.5.4 FINAL COMMISSIONING REPORT. A REPORT OF TEST PROCEDURES AND RESULTS IDENTIFYING FINAL COMMISSIONING REPORT SHALL BE DELIVERED TO THE BUILDING OWNER OR OWNER'S AUTHORIZED AGENT. THE REPORT SHALL BE ORGANIZED WITH MECHANICAL SYSTEM AND SERVICE HOT WATER SYSTEM FINDINGS IN SEPARATE SECTIONS TO ALLOW INDEPENDENT REVIEW. THE REPORT SHALL INCLUDE THE FOLLOWING:

1. RESULTS OF FUNCTIONAL PERFORMANCE TESTS.
  2. DISPOSITION OF DEFICIENCIES FOUND DURING TESTING, INCLUDING DETAILS OF CORRECTIVE MEASURES USED OR PROPOSED.
  3. FUNCTIONAL PERFORMANCE TEST PROCEDURES USED DURING THE COMMISSIONING PROCESS INCLUDING MEASURABLE CRITERIA FOR TEST ACCEPTANCE, PROVIDED HEREIN FOR REPEATABILITY.
- EXCEPTION: DEFERRED TESTS THAT CANNOT BE PERFORMED AT THE TIME OF REPORT PREPARATION DUE TO CLIMATIC CONDITIONS.

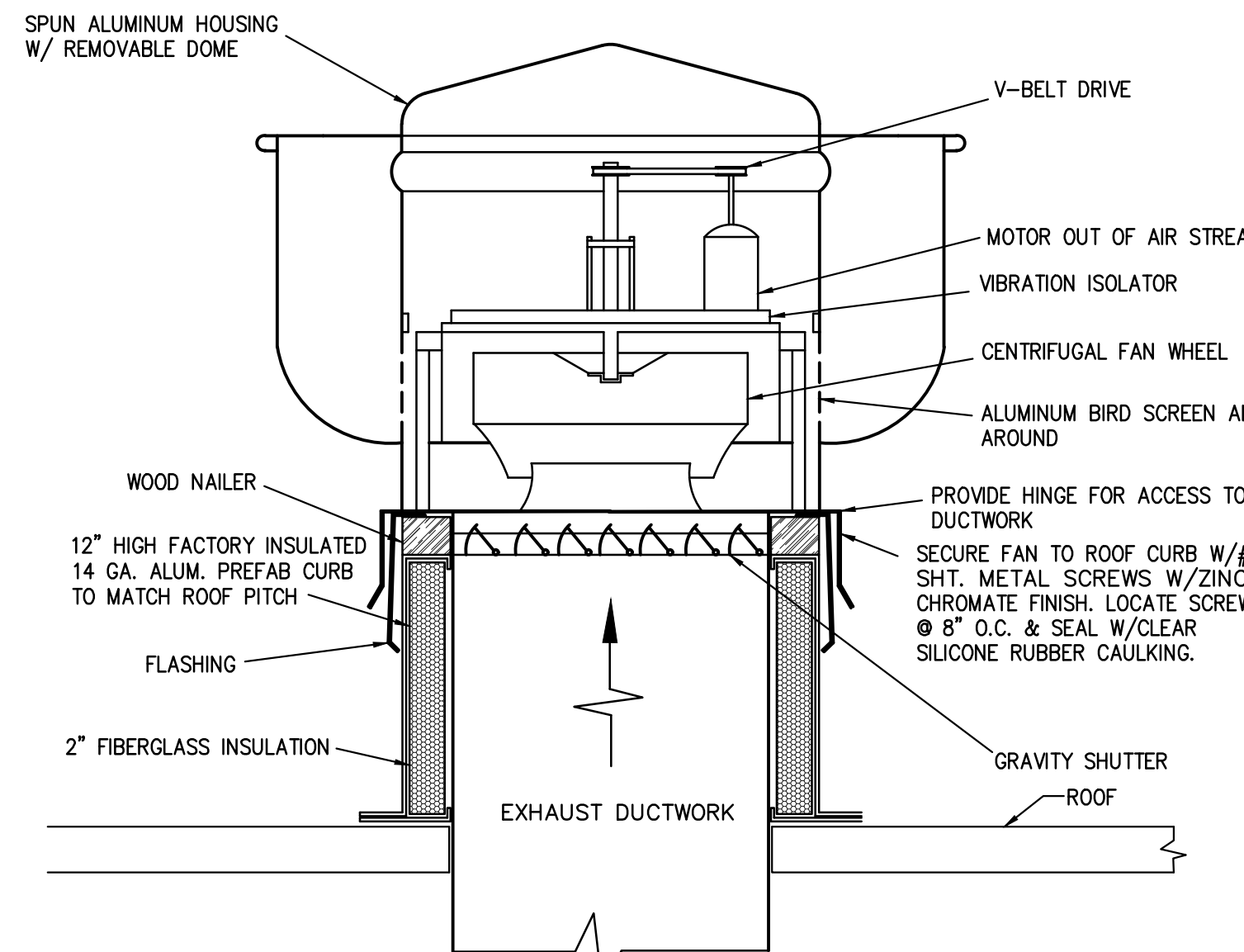

**1 UPBLAST EXHAUST FAN DETAIL**  
NO SCALE

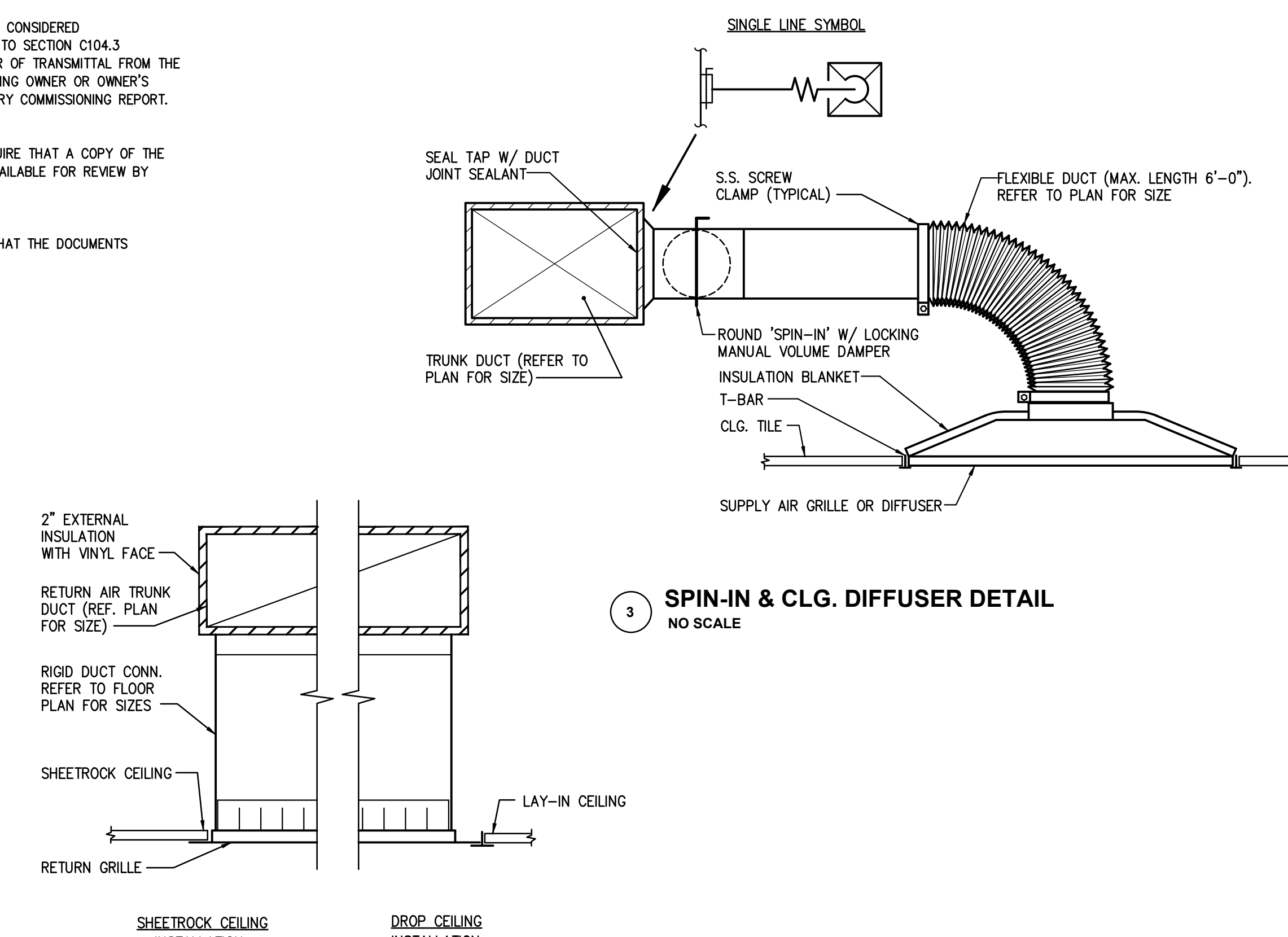

**2 RETURN AIR GRILLE DETAIL**  
NO SCALE

**3 SPIN-IN & CLG. DIFFUSER DETAIL**  
NO SCALE

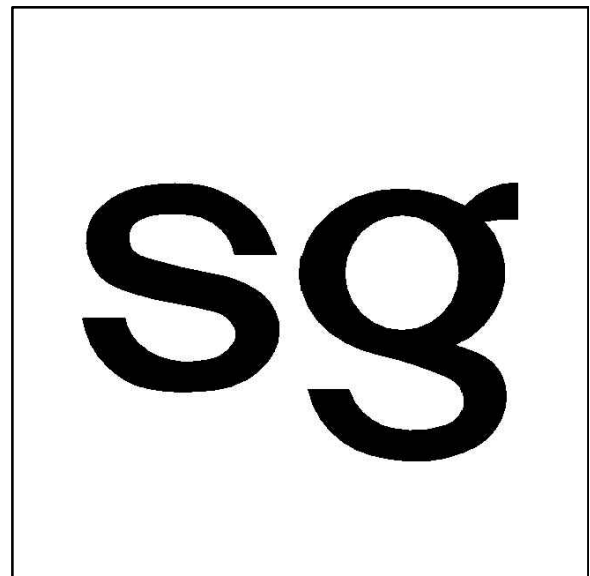

**sweetgreen**  
3101 W. EXPOSITION BLVD.  
LOS ANGELES, CALIFORNIA 90018

THESE DRAWINGS & SPECIFICATIONS ARE CONFIDENTIAL AND SHALL REMAIN THE SOLE PROPERTY OF SWEETGREEN CORPORATION. THEY SHALL NOT BE REPRODUCED OR COPIED IN ANY MANNER OR USED IN ANY PROJECT OR EXTENSION TO THIS PROJECT WITHOUT THE PRIOR WRITTEN CONSENT OF SWEETGREEN CORPORATION. THESE DRAWINGS & SPECIFICATIONS ARE INTENDED TO EXPRESS DESIGN INTENT FOR A PROTOTYPICAL SWEETGREEN STORE (WHICH IS SUBJECT TO CHANGE AT ANY TIME) AND MAY NOT REFLECT ACTUAL SITE CONDITIONS. NEITHER PARTY SHALL HAVE ANY OBLIGATION NOR LIABILITY TO THE OTHER EXCEPT AS STATED ABOVE UNTIL A WRITTEN AGREEMENT IS FULLY EXECUTED.

ARCHITECT OF RECORD:  
**FHA ARCHITECTS**  
FOOD + HOSPITALITY  
FIRM REGISTRATION NO. BR 3045

STAMP:  
**CONSTRUCTION ISSUE SET**  
03/22/2022  
*Nicholas Polcari*

PROJECT INFORMATION:  
**LAKewood**  
6400 GASTON AVE.  
DALLAS, TX 75214

DRAWN BY: MB  
CHECKED BY: ST  
PROJECT MANAGER: ST  
SG DESIGN MANAGER: KP  
SG CONSTR. MANAGER: JB  
PROJECT NO: 111020  
TEMPLATE VERSION: 04/30/2021

REVISIONS	REV.	DATE	DESCRIPTION

RECEIVED BY D4 CONSTRUCTION  
DATE: 03/24/2022

**MECHANICAL DETAILS & SPECIFICATIONS**

**JFTE**  
James F. Turner  
Engineers, L.P.  
Consulting Engineers  
8340 Moorpark Rd., Suite 160  
Dallas, Texas 75221  
TEL: 214-750-2900 Job #: 1113  
TX REGISTRATION # 33229

**M300**