

Submittal/Shop Drawing Review

Lakeway Animal Hospital



120 Sommerville Park Road
Raleigh, NC 27603
919-719-3475
NC Firm #: C-3824

- Approved
- Approved as Noted
- Confirm As Noted
- Revise and Resubmit
- Resubmit for Review
- Resubmit for Record
- Rejected
- Not Reviewed

We have not reviewed for electrical compliance. Please consult electrical engineer.

Engineer's review is for general conformance with the design concept of the project and the information given in the contract documents. The contractor is solely responsible for, and this review does not include: confirming and correlating all quantities and dimensions; selecting fabrication processes and means and methods of construction; coordinating the work with the other trades, and performing all work in a safe and satisfactory manner. Corrections or comments made on this submittal during this review do not relieve the contractor from compliance with the requirements of the contract documents or with the responsibilities listed above.

By: Ken Birley

Date: 8/30/2023



SUBMITTAL SHEET

Russco, Inc
23-039 - Lakeway Animal Hospital-Jefferson City, TN

Project: 23-039
Lakeway Animal Hospital-Jefferson City, TN
US HWY 11E
JEFFERSON CITY, TN
37760

Spec Section Num:
Submittal: 5
Revision: 0
Package:
Date: 8/28/2023 UTC

Submittal Title: HVAC Submittals
Submittal Detail: Please review attached HVAC submittals:
1. Equipment - RTU, Split system & accessories
2. Grilles & Diffusers, Flex & Taps, Fans, Louvers, Electric Heaters
3. ERV's
Response Due By: 8/31/2023 UTC

Contractor:
Michael Mastandrea
Russco, Inc

Contractor's Stamp

Architect:
Roger Layman
RL Architecture, LLC

Architect's Stamp

Response:
Comment:



Knoxville – Chattanooga – Nashville
www.reahvac.com

Friday, August 11, 2023

620 Reliability Circle
Knoxville, TN 37932
Phone: 865-675-4822
Fax: 865-675-4843

PROJECT:

Lakeway Animal Hospital
NVA Lakeway
Jefferson City, TN 37760

CONTRACTOR:

TN Mechanical & Industrial
PO Box 441
Jefferson City, TN 37760

ENGINEER:

Kairos Project Group, Inc.
120 Sommerville Park Road
Raleigh, NC 27603

SUBMITTED BY:

Ken Seaman
REA, Inc
620 Reliability Circle
Knoxville, TN 37932

EQUIPMENT SUBMITTED:

Lennox Packaged Rooftop Units
Lennox Ductless Split Systems

ELECTRONIC COPY FOR APPROVAL

SUBMITTAL

Rooftop Units

RTU-01 thru RTU-03:

Three (3) Lennox Packaged Heat Pump Rooftop Units with the following features:

- One (1) 4-Ton Unit
- Two (2) 5-Ton Units
- Direct Drive ECM Fans
- Downflow Orientation
- 208V/3P Power
- Disconnect Factory Installed
- Built-In BACnet IP and MS/TP
- Electric Heat per schedule
- Hinged Access Doors
- Tube and Fin Coil System Factory Installed
- 2" MERV 4 Filters - Factory Installed
- Manual OAD - Field Installed
- 14" Downflow Curb
- Coil/Hail Guards
- Programmable Thermostat

The following items are not included in this Submittal, and are to be provided by others:

1st Year Service/Labor, Installation, Startup, Power or Control Wiring, Piping/Linesets, Vibration Isolation, Seismic Isolation, Smoke Detectors, Firestats, or anything not mentioned above.



Project Submittal

Project Name: Lakeway Animal Hospital (V.E.)
Project Number: 472454
Project Altitude: 861
Project Location:
Jefferson City, Tennessee US

Date: 8/11/2023
Quote: 362657
Roof Top Units: 3
Split Systems: 0

Customer: Rome Eddleman & Assoc Inc
Engineer: Pending Engineer

Table of Contents

Tag	Qty	Model	Description
<u>RTU-01</u>	1	LRP14HP048	LRP14HP048 1HP TF
<u>RTU-02 / RTU-03</u>	2	LRP14HP060	LRP14HP060 1HP TF
<u>Miscellaneous Items</u>			

Revit® Building Information Modeling (BIM) - [Click here](#)

AutoCAD® Templates - [Click here](#)



Tag: RTU-01
Model: LRP14HP048 - LRP14HP048 1HP TF

UNIT OVERVIEW

Voltage	SEER EER	IPLV	HSPF	MCA/MOC P (amp)	Gross Cooling Ttl/Sens (MBH)	Net Cooling Ttl/Sens (MBH)	Supply Air Flow (cfm)	ESP/TSP (in.WC)	EAT DB/WB (°F)	LAT DB/WB (°F)
208V 3Ph 60Hz	14 11		8	34 / 35	48.2 / 38.7	45.8 / 36.3	1,685	0.75 / 0.80	80.0 / 67.0	56.3 / 56.3

COOLING

Cooling Performance			Temperatures (DB/WB °F)		
Gross Cooling (Ttl/Sens)	48.2 / 38.7 MBH		Ambient	95.0	
Net Cooling (Ttl/Sens)	45.8 / 36.3 MBH		Entering	80.0	
Coil Moisture Removal	8.96 lb/hr		Leaving - (Coil)	56.3	
System Moisture Removal	8.96 lb/hr		Leaving - (Unit)	57.8	
				57.5	

ARI Performance		Compressors		Refrigerant		Condensate Drain	
ARI Cooling	48.0 / 46.0 MBH	Cooling Stages	1	Type	R-410A	Qty	1
ARI Power	3,760 W	Compressor Qty	1	Charge	10 lbs. 10 oz.	Size	75 in.
		Compressor RLA	13.8 amp			Pipe Thread	npt

HEATING

Heating Performance			Temperatures (DB/WB °F)		
HP Output @ Design	25.9 MBH		Ambient	10.0	
COP (High/Low)	3.70 / 2.30		Entering	70.0	
HP Power (High/Low)	4.5 / 3.4 kW		HP Design	17.0	
Electric Heat Size	10.0 kW		Leaving	98.3	
Elec Heat - Heat Rise	14.1 °F				
HP - Heat Rise @ Design	14.2 °F				

VENTILATION

Air Flow (cfm)		Supply Fan		Air Resistance (in.WC)	
Supply	1,685	Nominal Power	1.00 hp	Total	0.80
Outdoor	54	Required Power	1.00 hp	Ext Supply	0.75
	0	Drive Type	ECM Direct Drive		
		Speed	3		

AIR RESISTANCE - OPTIONS/ACCESSORIES (in.WC)

Wet Coil	Humiditrol	Heat	Economizer	Filters	Diffuser	Exhaust	ERW
0.05							

ELECTRICAL

Voltage	208V 3Ph / 60Hz	Compressor RLA	13.8 amp
MCA	34 amp	Cooling FLA Total	23.2 amp
MOC P	35 amp	Condenser FLA	1.8 amp
Condenser Power	280 W	Supply Fan FLA	7.6 amp
Oper Range-Nom Volt	+/- 10%		

ADDITIONAL DATA

Cabinet	47.62 in. x 56.12 in. x 44.88 in.	Total Weight	534 lb
Downflow Supply	19.5 in. x 11.5 in.	Base Unit Net Weight	526 lb
Downflow Return	19.5 in. x 11.5 in.	OAS/Econ Weight	0 lb
Filters	(2) 20.0 in. x 20.0 in. x 1.0 in.	Electric Heat Weight	8 lb
Sound Rating	0 dBA	Curb Weight	0 lb



Tag: RTU-01

Factory Installed Options

- Standard Cap, Std Packaging
- Unit Orientation Downflow
- 208/220/230/240V 3Phase
- Supply Motor - 1.0 Hp ECM - Multi-Tap Constant Torque
- Tube and Fin Coil System Factory Installed

Field Installed Outdoor Air Damper Package

Field Installed Accessories

Catalog Number	Qty	Description
21U19	1	Motorized OAD Field Installed
21J33	1	Electric Heat 10kW Field Installed
21J19	1	14" Downflow - Clip Curb Field Installed
21J78	1	Bottom Power Entry Kit Field Installed
13H14	1	ComfortSense® 7500 Field Installed

Product Features

Cabinet

- Durable Outdoor Enamel Paint Finish
- Totally Enclosed Outdoor Fan Motor
- PVC Coated Fan Guard
- Isolated Compressor Compartment

Cooling System

- Scroll Compressor
- High Capacity Driers
- High Pressure Switch (Manual Reset)
- Crankcase Heater
- Pre-charged Refrigeration System
- Internal Pressure Relief Valve

Control System

- Fan and Limit Controls
- Overload Protection

Compliance

- Components are Bonded for Grounding
- Factory Test Operated

Warranty

- Limited warranty on compressor of 5 years
- Limited warranty on all other components of 1 year
- See Limited Warranty Certificate included with unit for details

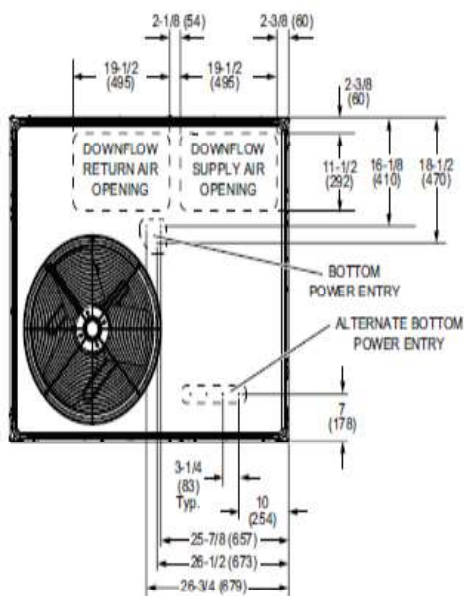

TOP VIEW (Base)

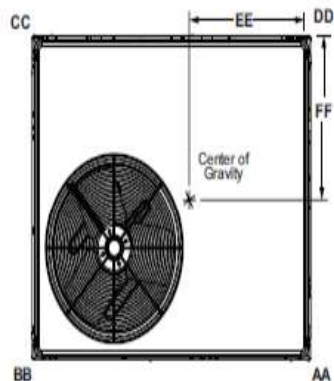

TOP VIEW
(Corner Weight and Center of Gravity)

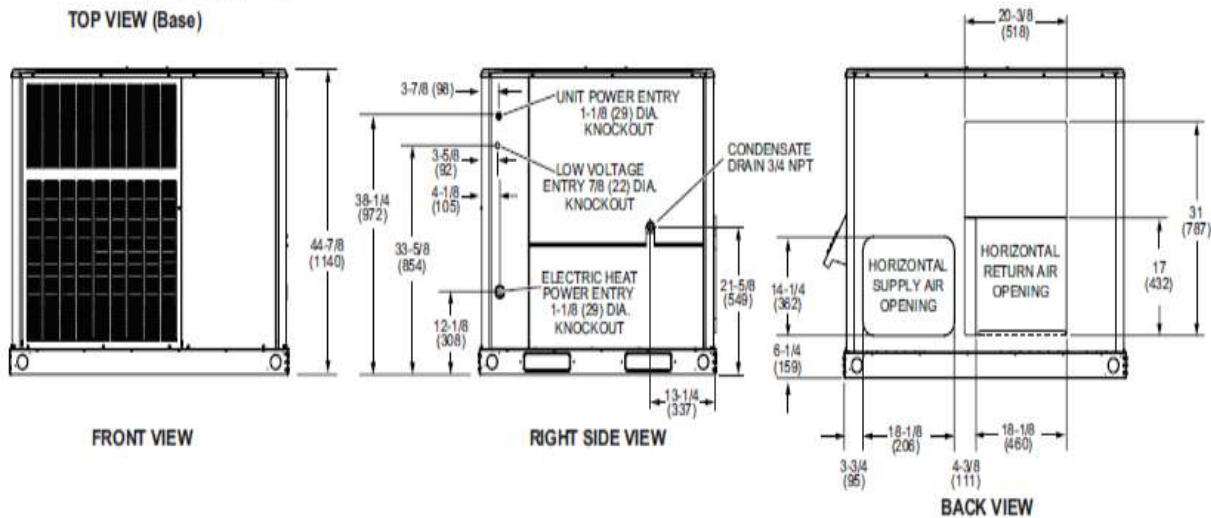

FRONT VIEW

RIGHT SIDE VIEW

BACK VIEW



MANUAL OUTDOOR AIR DAMPERS

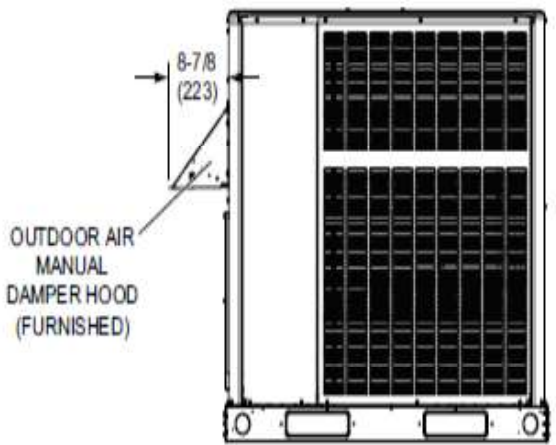

LEFT SIDE VIEW

MOTORIZED OUTDOOR AIR DAMPERS

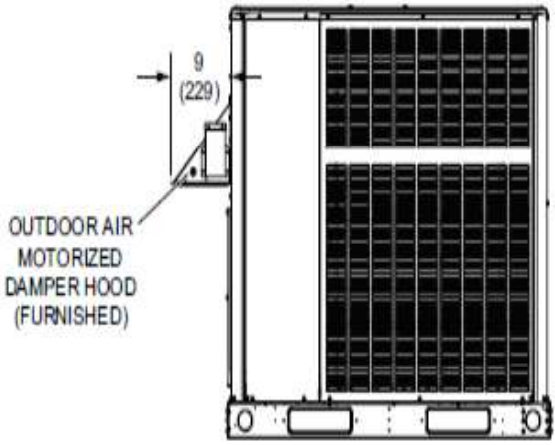

LEFT SIDE VIEW



NOTE - Outdoor Air Hood and Panel replaces existing panel on unit.

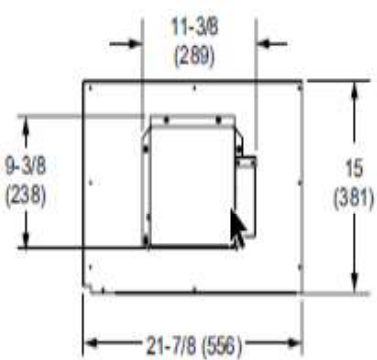
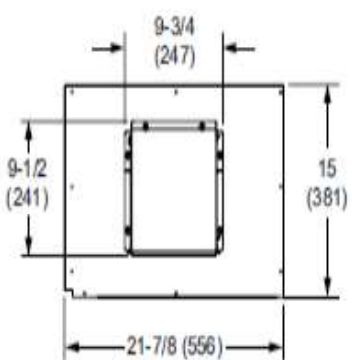

CLIP CURB

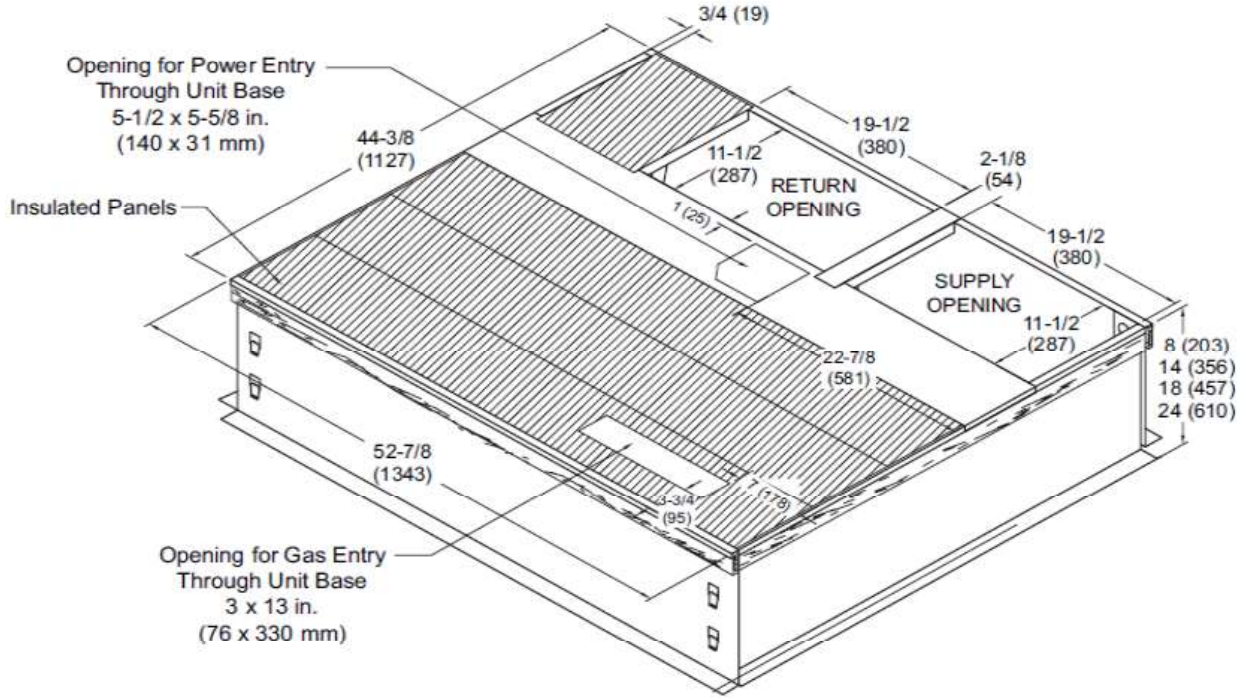

NOTE - Roof deck may be omitted within confines of curb.

TYPICAL FLASHING DETAIL FOR ROOF CURB

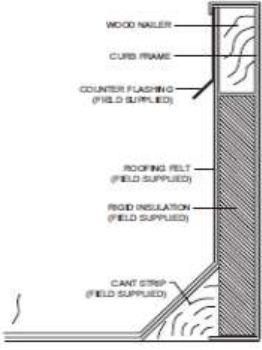

DETAIL ROOF CURB

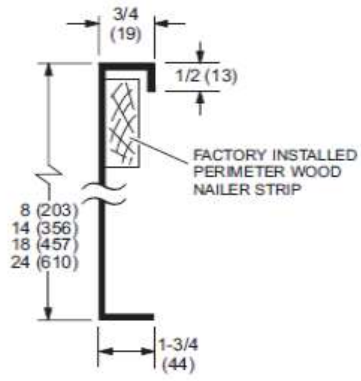



ComfortSense[®]

**4 Heat / 2 Cool
Universal Multi-Stage**

RTU-02 & RTU-03



Project Submittal

Tag: RTU-02 / RTU-03
 Model: LRP14HP060 - LRP14HP060 1HP TF

UNIT OVERVIEW

Voltage	SEER EER	IPLV	HSPF	MCA/MOC P (amp)	Gross Cooling Ttl/Sens (MBH)	Net Cooling Ttl/Sens (MBH)	Supply Air Flow (cfm)	ESP/TSP (in.WC)	EAT DB/WB (°F)	LAT DB/WB (°F)
208V 3Ph 60Hz	14 11		8	34 / 35	60.4 / 47.0	58.0 / 44.6	1,985	0.75 / 0.80	80.0 / 67.0	57.0 / 57.0

COOLING

Cooling Performance		Temperatures (DB/WB °F)		
Gross Cooling (Ttl/Sens)	60.4 / 47.0 MBH	Ambient	95.0	78.0
Net Cooling (Ttl/Sens)	58.0 / 44.6 MBH	Entering	80.0	67.0
Coil Moisture Removal	12.61 lb/hr	Leaving - (Coil)	57.0	57.0
System Moisture Removal	12.61 lb/hr	Leaving - (Unit)	58.2	57.4

ARI Performance		Compressors		Refrigerant		Condensate Drain	
ARI Cooling	59.0 / 57.0 MBH	Cooling Stages	1	Type	R-410A	Qty	1
ARI Power	4,850 W	Compressor Qty	1	Charge	11 lbs. 9 oz.	Size	75 in.
		Compressor RLA	13.2 amp			Pipe Thread	npt

HEATING

Heating Performance		Temperatures (DB/WB °F)	
HP Output @ Design	34.9 MBH	Ambient	10.0
COP (High/Low)	3.70 / 2.40	Entering	70.0
HP Power (High/Low)	5.6 / 4.6 kW	HP Design	17.0
Electric Heat Size	10.0 kW	Leaving	98.2
Elec Heat - Heat Rise	12.0 °F		
HP - Heat Rise @ Design	16.3 °F		

VENTILATION

Air Flow (cfm)		Supply Fan		Air Resistance (in.WC)	
Supply	1,985	Nominal Power	1.00 hp	Total	0.80
Outdoor	150	Required Power	1.00 hp	Ext Supply	0.75
	0	Drive Type	ECM Direct Drive		
		Speed	3		

AIR RESISTANCE - OPTIONS/ACCESSORIES (in.WC)

Wet Coil	Humiditrol	Heat	Economizer	Filters	Diffuser	Exhaust	ERW
0.05							

ELECTRICAL

Voltage	208V 3Ph / 60Hz	Compressor RLA	13.2 amp
MCA	34 amp	Cooling FLA Total	22.6 amp
MOC P	35 amp	Condenser FLA	1.8 amp
Condenser Power	280 W	Supply Fan FLA	7.6 amp
Oper Range-Nom Volt	+/- 10%		

ADDITIONAL DATA

Cabinet	47.62 in. x 56.12 in. x 44.88 in.	Total Weight	544 lb
Downflow Supply	19.5 in. x 11.5 in.	Base Unit Net Weight	536 lb
Downflow Return	19.5 in. x 11.5 in.	OAS/Econ Weight	0 lb
Filters	(2) 20.0 in. x 20.0 in. x 1.0 in.	Electric Heat Weight	8 lb
Sound Rating	0 dBA	Curb Weight	0 lb



Tag: RTU-02 / RTU-03

Factory Installed Options

- Standard Cap, Std Packaging
- Unit Orientation Downflow
- 208/220/230/240V 3Phase
- Supply Motor - 1.0 Hp ECM - Multi-Tap Constant Torque
- Tube and Fin Coil System Factory Installed

Field Installed Outdoor Air Damper Package

Field Installed Accessories

Catalog Number	Qty	Description
21U19	2	Motorized OAD Field Installed
21J33	2	Electric Heat 10kW Field Installed
21J19	2	14" Downflow - Clip Curb Field Installed
21J78	2	Bottom Power Entry Kit Field Installed
13H14	2	ComfortSense® 7500 Field Installed

Product Features

Cabinet

- Durable Outdoor Enamel Paint Finish
- Totally Enclosed Outdoor Fan Motor
- PVC Coated Fan Guard
- Isolated Compressor Compartment

Cooling System

- Scroll Compressor
- High Capacity Driers
- High Pressure Switch (Manual Reset)
- Crankcase Heater
- Pre-charged Refrigeration System
- Internal Pressure Relief Valve

Control System

- Fan and Limit Controls
- Overload Protection

Compliance

- Components are Bonded for Grounding
- Factory Test Operated

Warranty

- Limited warranty on compressor of 5 years
- Limited warranty on all other components of 1 year
- See Limited Warranty Certificate included with unit for details

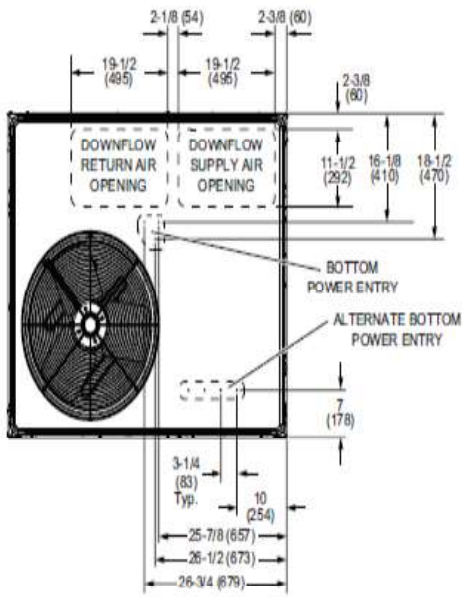

TOP VIEW (Base)

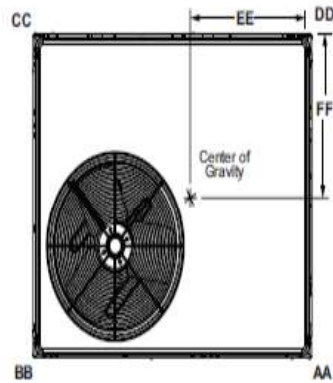

**TOP VIEW
(Corner Weight and Center of Gravity)**

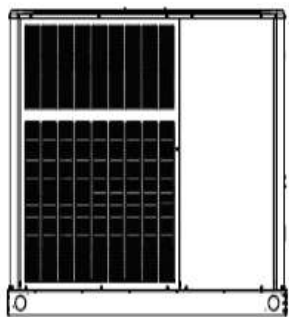

FRONT VIEW

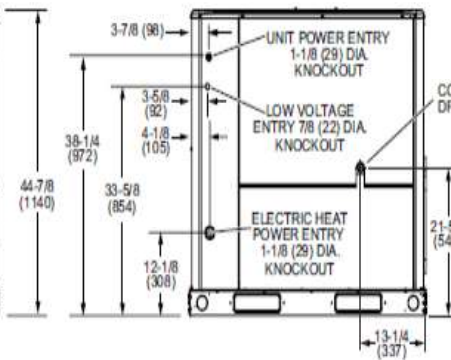

RIGHT SIDE VIEW

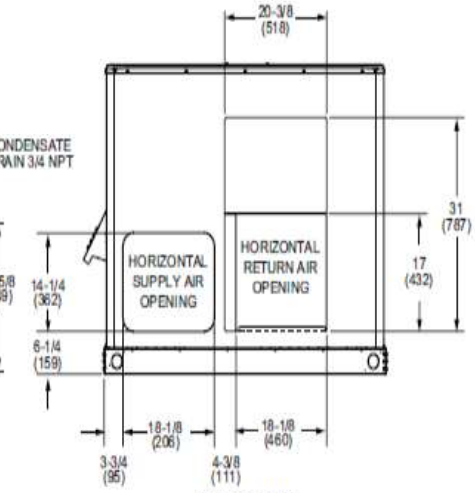

BACK VIEW



MANUAL OUTDOOR AIR DAMPERS

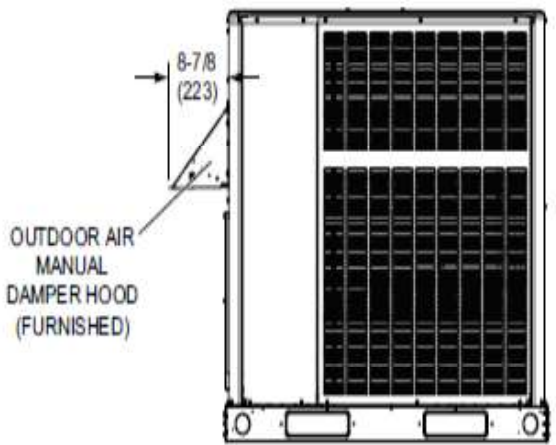

LEFT SIDE VIEW

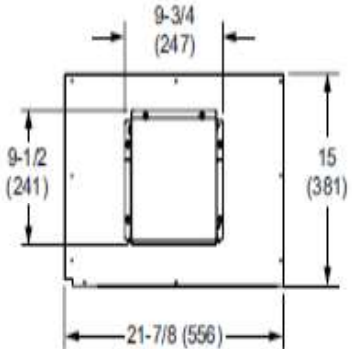
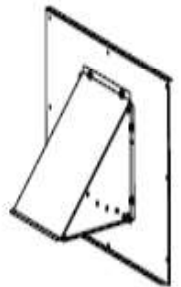

MOTORIZED OUTDOOR AIR DAMPERS

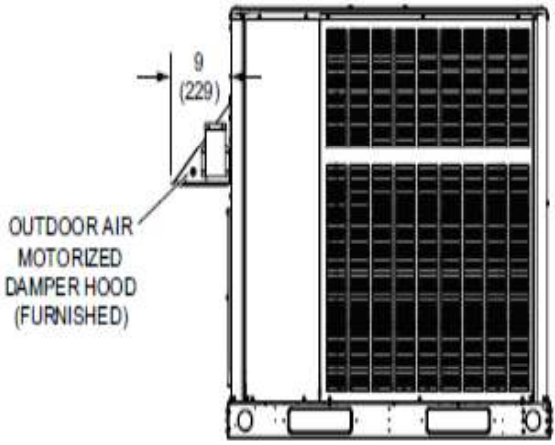

LEFT SIDE VIEW

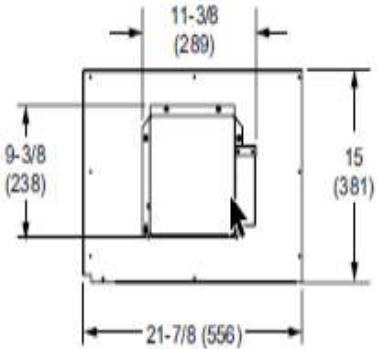

NOTE - Outdoor Air Hood and Panel replaces existing panel on unit.



CLIP CURB

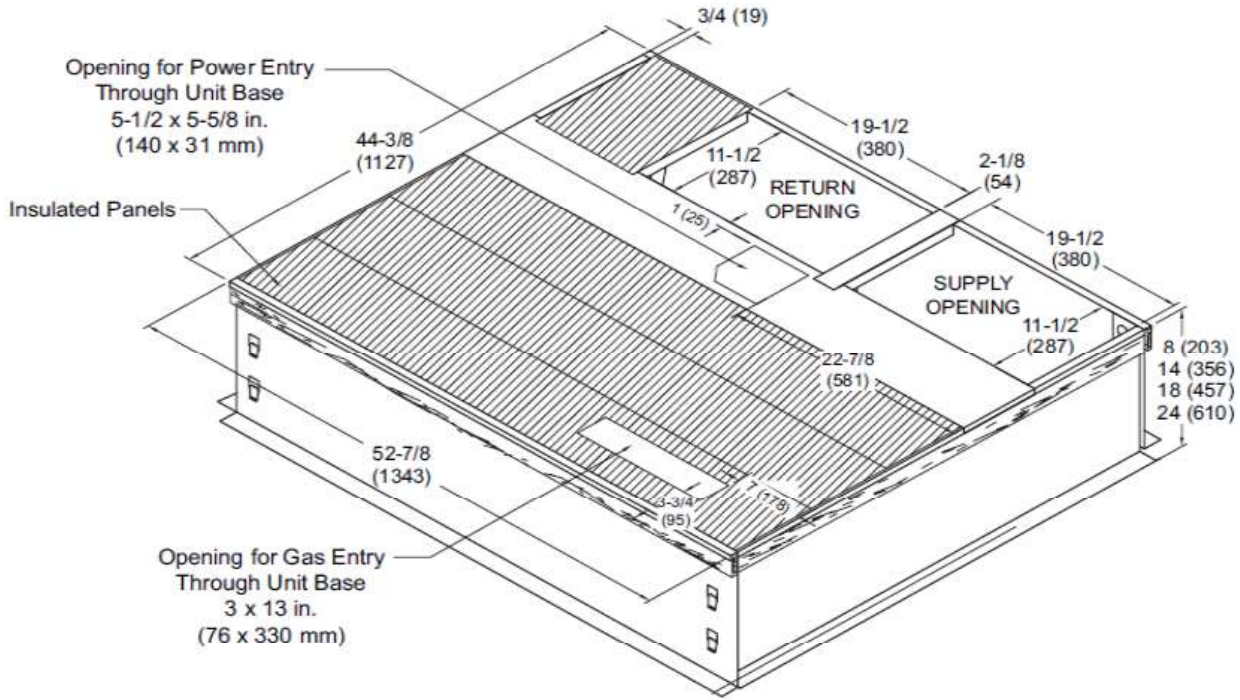

NOTE - Roof deck may be omitted within confines of curb.

TYPICAL FLASHING DETAIL FOR ROOF CURB

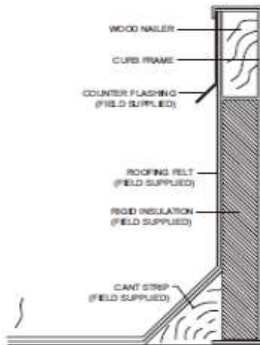

DETAIL ROOF CURB

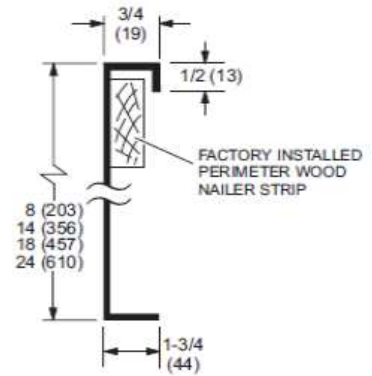



ComfortSense®

**4 Heat / 2 Cool
Universal Multi-Stage**

Split System Air Source Heat Pumps

HP-4 / HW-1 and HP-5 / CA-1 thru CA-4:

Two (2) Lennox Ductless Split System Heat Pumps with the following features:

- One (1) 009 MBH Nominal Capacity Unit - Single Zone - Low Ambient
- One (1) 036 MBH Nominal Capacity Unit - Multi-Zone - Low Ambient
- Single Zone Outdoor Unit has One (1) Wall Mounted Indoor Unit
- Multi-Zone Outdoor Unit has Four (4) Ceiling Cassette Indoor Units
- Single Point Power - 208V/1P Power
- Programmable Thermostats - as specified

The following items are not included in this Submittal, and are to be provided by others:

1st Year Service/Labor, Installation, Startup, Power or Control Wiring, Piping/Linesets, Vibration Isolation, Seismic Isolation, or anything not mentioned above.



Project Submittal

Tag: Miscellaneous Items

Miscellaneous Items

Tag	Catalog Number	Qty	Description
HP-4 / HW-1			
	22B14	1	MLB009S4S-1P LOW AMB SZ ODU 9K 208/230V
	22B21	1	MWMC009S4-1P MS IDU Wall 9k 208/230V
	22U20	1	M0STAT64Q-2Wired PGM Controller CBL D
HP-5 / CA-1 thru CA-4			
	22B20	1	MLB036S4M-1P LOW AMB MZ ODU 36K 208/230V
	22B21	4	MWMC009S4-1P MS IDU Wall 9k 208/230V
	22U20	4	M0STAT64Q-2Wired PGM Controller CBL D



**SUBMITTAL DATA – WALL MOUNTED
MLB009S4S-1P – MWMC009S4-1P
SINGLE ZONE MINI-SPLIT HEAT PUMP**

Job: _____
 Location: _____
 Schedule No.: _____
 System Designation: _____

Engineer: _____
 Architect: _____
 Date: _____
 For: Reference Approval Review Construction

FEATURES

Outdoor Unit: MLB009S4S-1P



- DC Inverter Control
- Compressor Overcurrent Protection
- Base Pan Heater
- Defrost Control

Indoor Unit: MWMC009S4-1P



- Pre-Heat Function
- Auto Restart
- Three Selectable Fan Speeds
- Flare Connections
- LED Readout
- Multi-Refrigerant Outlet
- Wireless Remote Included

PIPING

Line Set and Elevation Guidelines

Maximum Line Set Length ft. (m)	98 (30)
Maximum Elevation - Outdoor Unit Below/Above Indoor Unit ft. (m)	66 (20)
Liquid Line Set Diameter (in.)	1/4
Gas Line Set Diameter (in.)	3/8
Pre-Charged (ft.)	25
Additional Charge of Refrigerant (oz/ft.)	0.16

PRODUCT WARRANTY

Compressor – Twelve year limited warranty*
 All other covered components - Twelve year limited warranty*
 *Product registration required

OPTIONAL ACCESSORIES

Non-Programmable Controller (M0STAT61Q-1)
 Programmable Controller (M0STAT64Q-2)
 Hail Guard Set (M9GARD19Q-1/24M81)



NOTE – Due to Lennox' ongoing commitment to quality, Specifications, Ratings, and Dimensions are subject to change without notice and without incurring liability. Improper installation, adjustment, alteration, service or maintenance can cause property damage or personal injury. Installation and service must be performed by a qualified installer and servicing agency.



SUBMITTAL DATA – WALL MOUNTED MLB009S4S-1P – MWMC009S4-1P SINGLE ZONE MINI-SPLIT HEAT PUMP

OUTDOOR SPECIFICATIONS

PERFORMANCE

Cooling Capacity (Max/Min) (Btu/h) ¹	9,000 (14,300/3,300)
EER2	16.2
SEER2	28.1
Heating Capacity (Max/Min) (Btu/h) ¹	12,000 (15,200/5,000)
HSPF2	11.5
Outdoor Fan Total Air Volume (CFM)	1,120
Ambient Temperature Operating Range	
Cooling	-22°F - 122°F
Heating	-22°F - 86°F

ELECTRICAL DATA

Power Supply (V/Hz/Φ)	208-230/60/1
Minimum Circuit Ampacity (A)	15
Maximum Overcurrent Protection (A)	15
Outdoor Fan Motor RLA (A)	0.4
No. of Compressors	1

GENERAL DATA

Connection Ratio (%)	100%
Max. # of Indoor Units	1 unit
Sound Data (dBA) - Cooling/Heating	54.5/54.5
Refrigerant type	R-410A
Factory refrigerant charge	2 lbs. 9 oz.

DIMENSIONS

Unit Dimensions (in)	Height	21-7/8
	Width	34-3/8
	Depth	12-1/8
Shipping Weight (lb)		80
Net Weight (lb)		74

NOTES

- Cooling and Heating Capacity data is rated at the following conditions:
Cooling: 80°FDB / 67°FWB Indoor, 95°FDB Outdoor
Heating: 70°FDB Indoor, 47°FDB / 43°FWB Outdoor

OUTDOOR DIMENSIONAL DRAWINGS - INCHES (MM)

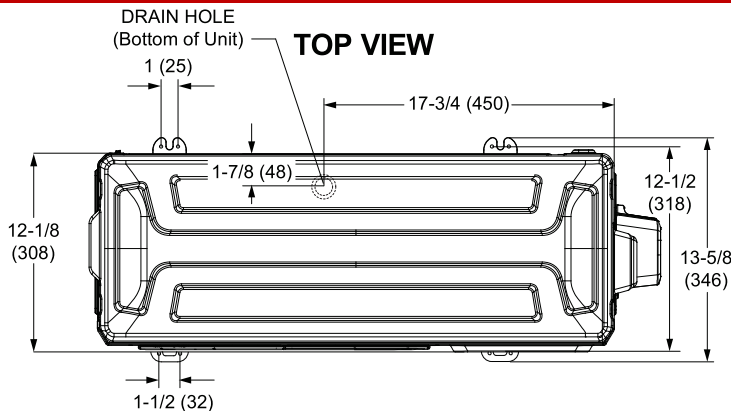

FRONT VIEW

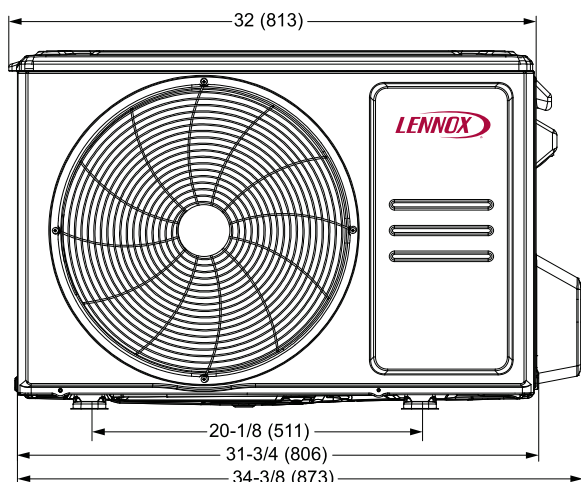

SIDE VIEW

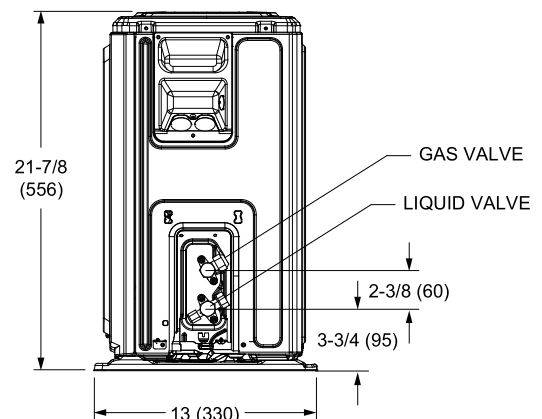

NOTE – Due to Lennox' ongoing commitment to quality, Specifications, Ratings, and Dimensions are subject to change without notice and without incurring liability. Improper installation, adjustment, alteration, service or maintenance can cause property damage or personal injury. Installation and service must be performed by a qualified installer and servicing agency.



**SUBMITTAL DATA – WALL MOUNTED
MLB009S4S-1P – MWMC009S4-1P
SINGLE ZONE MINI-SPLIT HEAT PUMP**

INDOOR SPECIFICATIONS

PERFORMANCE			DIMENSIONS		
AIR FLOW (CFM)	High	335	Unit Dimensions (in)	Height	11-3/4
	Medium	230		Width	33-3/8
	Low	176		Depth	9
SOUND PRESSURE (dBA)	High	38	Shipping Weight (lb)	23	
	Medium	34	Net Weight (lb)	29	
	Low	23			
ELECTRICAL DATA			NOTES		
Power Supply (V/Hz/Φ)	Supplied by ODU		1. Cooling and Heating Capacity data is rated at the following conditions:		
Rated Load Amps (RLA)	0.25		Cooling: 80°FDB / 67°FWB Indoor, 95°FDB Outdoor		
Power Output (W)	20		Heating: 70°FDB Indoor, 47°FDB / 43°FWB Outdoor		

INDOOR DIMENSIONAL DRAWINGS - INCHES (MM)

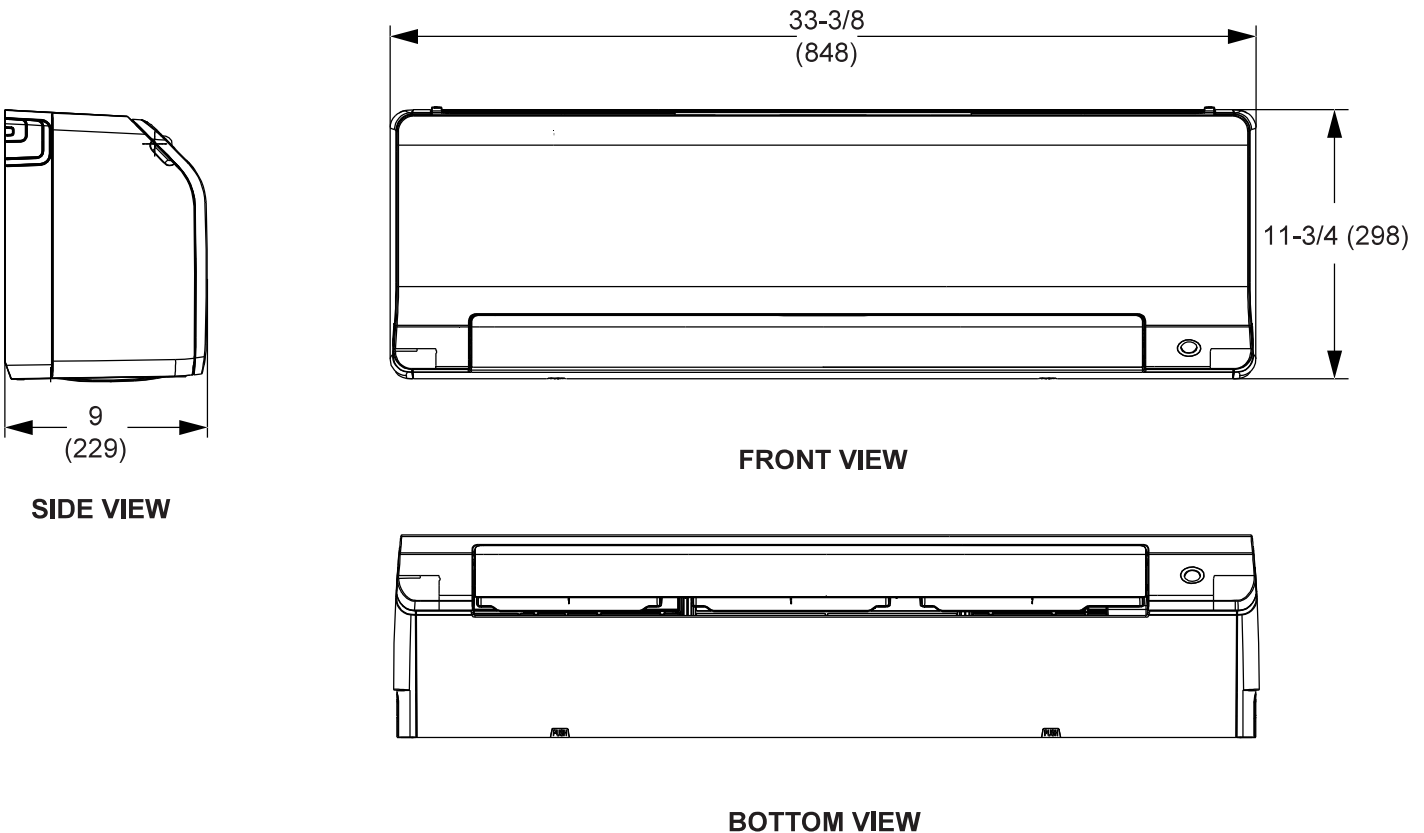

NOTE – Due to Lennox’ ongoing commitment to quality, Specifications, Ratings, and Dimensions are subject to change without notice and without incurring liability. Improper installation, adjustment, alteration, service or maintenance can cause property damage or personal injury. Installation and service must be performed by a qualified installer and servicing agency.



SUBMITTAL DATA – WALL-MOUNTED MWMC009S4-1P

MULTI-ZONE MINI-SPLIT HEAT PUMP

Job: _____

Location: _____

Schedule No.: _____

System Designation: _____

Engineer: _____

Architect: _____

Date: _____

For: Reference Approval Review Construction

FEATURES

- Pre Heat Function
- Multi-Refrigerant Outlet
- Flare Connections
- Refrigerant R-410A
- Auto Restart
- Three Speed Fan
- LED Readout Panel
- Wireless Remote Controller included

Product Warranty

All covered components - Twelve year limited warranty.
Product registration required.

SPECIFICATIONS

PERFORMANCE		
Cooling Capacity ¹ (Btu/h)		9,000
Heating Capacity ¹ (Btu/h)		9,000
Airflow (CFM)	High	335
	Medium	230
	Low	176
External Static Pressure (in. w.g.)		-
Sound Pressure (dBA)	High	38.0
	Medium	34.0
	Low	23.0
ELECTRICAL DATA		
Power Supply (V/Hz/Φ)		208-230/60/1
Rated load amps (RLA)		0.25
Power Output (W)		20
DIMENSIONS		
Unit Dimensions (in)	Height	11-3/4
	Width	33-3/8
	Depth	9
Liquid Pipe Connection (in)		1/4
Gas Pipe Connection (in)		3/8
Condensate drain connection (in)		1
Unit Shipping Weight (lb)		29
Unit Net Weight (lb)		23



OPTIONAL ACCESSORIES

Non-Programmable Controller (M0STAT61Q-1):	
Wireless Remote Controller (RG10L-WM):	1+
Programmable Controller (M0STAT64Q-1):	

NOTES

- Cooling and Heating capacity data is rated at the following conditions:
Cooling: 80°FDB / 67°FWB Indoor, 95°FDB Outdoor
Heating: 70°FDB Indoor, 47°FDB / 43°FWB Outdoor



NOTE – Due to Lennox' ongoing commitment to quality, Specifications, Ratings and Dimensions subject to change without notice and without incurring liability. Improper installation, adjustment, alteration, service or maintenance can cause property damage or personal injury. Installation and service must be performed by a qualified installer and servicing agency.



**SUBMITTAL DATA – WALL-MOUNTED
MWMC009S4-1P
MULTI-ZONE MINI-SPLIT HEAT PUMP**

DIMENSIONAL DRAWINGS - INCHES (MM)

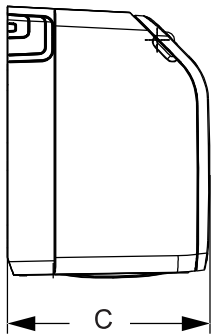

SIDE VIEW

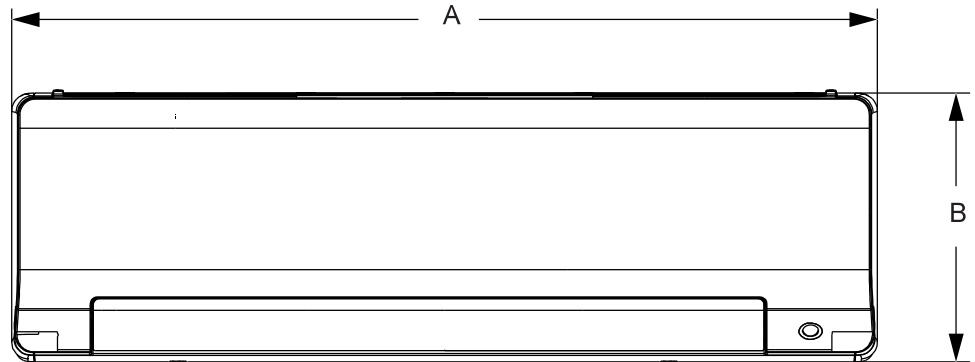

FRONT VIEW

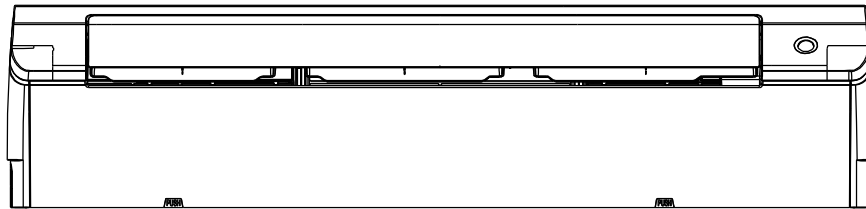

BOTTOM VIEW

Size	A		B		C	
	in.	mm	in.	mm	in.	mm
MWMC009, 012	33-3/8	848	11-3/4	298	9	229
MWMC018	40	1016	12-1/2	318	9-1/2	241
MWMC024, 030	46-7/8	1191	14-5/8	371	11	279

NOTE – Due to Lennox' ongoing commitment to quality. Specifications, Ratings and Dimensions subject to change without notice and without incurring liability. Improper installation, adjustment, alteration, service or maintenance can cause property damage or personal injury. Installation and service must be performed by a qualified installer and servicing agency.



SUBMITTAL DATA - CONTROLS

M0STAT64Q-2

MINI-SPLIT HEAT PUMP

Job: _____

Location: _____

Schedule No.: _____

System Designation: _____

Engineer: _____

Architect: _____

Date: _____

For: Reference Approval Review Construction

Programmable Controller

FEATURES AND FUNCTIONS

- Simple, user-friendly design with large backlit display for easy viewing
- Operation – On/Off
- Operation Mode – Cool/Heat/Fan/Dry/Auto
- Fan Speed – Low/Medium/High/Auto
- Programmable Schedule
 - Up to 8 events per day with unique daily schedules
 - Scheduled events include option for mode, setpoint, and fan speed
 - Copy/paste function for easy schedule programming
- Timer operation for turning indoor unit on/off in scheduled increments
- Option to sense temperature from controller using “Follow me” function
- °F or °C field selectable – default °F
- Built-in system diagnostics



DISPLAY

SPECIFICATIONS

PERFORMANCE

Input Voltage (V)	5 VDC
Communication Cabling	Factory 4-wire harness
Setpoint Range	62°F ~ 86°F
Operating Temperature Range	23°F ~ 110°F
Operating Humidity Range (RH)	40% ~ 90%

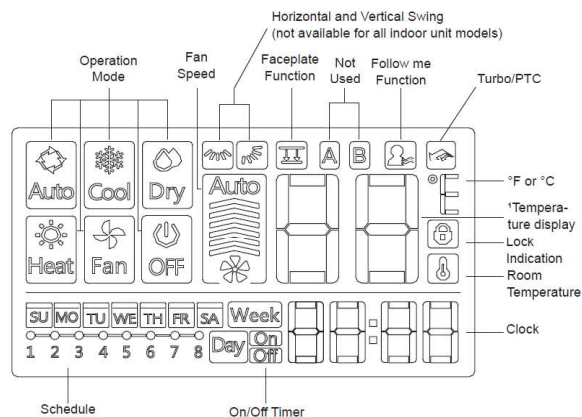

* Displays cooling setpoint, heating setpoint or room temperature

NOTE – Due to Lennox’ ongoing commitment to quality, Specifications, Ratings, and Dimensions are subject to change without notice and without incurring liability. Improper installation, adjustment, alteration, service or maintenance can cause property damage or personal injury. Installation and service must be performed by a qualified installer and servicing agency.

HP-5 / CA-1 Through CA-4



SUBMITTAL DATA – OUTDOOR UNIT MLB036S4M-1P MULTI-ZONE MINI-SPLIT HEAT PUMP

Job: _____
 Location: _____
 Schedule No.: _____
 System Designation: _____

Engineer: _____
 Architect: _____
 Date: _____
 For: Reference Approval Review Construction

FEATURES

Outdoor Unit: MLB036S4M-1P

Indoor Unit Options: Ducted OR Non-Ducted



- Low Ambient Cooling/Heating
- Defrost Control
- DC Inverter Control
- Base Pan Heater
- Crankcase Heater



Piping

Line Set and Elevation Guidelines

Maximum Number of Indoor Units/Zones	4
Liquid + Gas pipe (flare)	(3) 1/4 liq. + (3) 3/8 gas (1) 1/4 liq. + (1) 1/2 gas
Maximum Pipe Length ft. (m)	262 ft. (80 m)
Maximum Line Set Length - Furthest Indoor Unit	115 ft. (35 m)
Maximum Elevation - Outdoor Unit Below/Above Indoor Unit ft. (m)	49 ft. (15m)
Pre-Charged (ft.)	25 ft.
Additional Charge of Refrigerant (oz/ft.)	0.16

PRODUCT WARRANTY

Compressor – Twelve year limited warranty*
 All other covered components - Twelve year limited warranty*
 *Product registration required

OPTIONAL ACCESSORIES

Non-Programmable Controller (M0STAT61Q-1)
 Programmable Controller (M0STAT64Q-2)



NOTE – Due to Lennox' ongoing commitment to quality, Specifications, Ratings, and Dimensions are subject to change without notice and without incurring liability. Improper installation, adjustment, alteration, service or maintenance can cause property damage or personal injury. Installation and service must be performed by a qualified installer and servicing agency.

HP-5 / CA-1 Through CA-4



SUBMITTAL DATA – OUTDOOR UNIT MLB036S4M-1P MULTI-ZONE MINI-SPLIT HEAT PUMP

OUTDOOR SPECIFICATIONS

PERFORMANCE

Cooling Capacity (Btu/h) ¹	Ducted	36,000
	Non-Ducted	36,000
EER	Ducted	11.3
	Non-Ducted	13.6
SEER	Ducted	19.0
	Non-Ducted	21.8
Heating Capacity (Btu/h) ¹	Ducted	37,000
	Non-Ducted	36,400
HSPF	Ducted	11.0
	Non-Ducted	11.0
Outdoor Fan Total Air Volume (CFM)		4500
Ambient Temperature Operating Range		
Cooling		-22 - 122°F
Heating		-22 - 86°F

ELECTRICAL DATA

Power Supply (V/Hz/Φ)	208-230/60/1
Minimum Circuit Ampacity (A)	35.0
Maximum Overcurrent Protection (A)	50.0
Outdoor Fan Motor RLA (A)	(2) 1.0
No. of Compressors	1

GENERAL DATA

Connection Ratio (%)	66% to 133%
Max. # of Indoor Units	Up to 4 units
Sound Data (dBA) - Cooling/Heating	63/63
Refrigerant type	R-410A
Factory refrigerant charge	10 lbs. 2 oz.

DIMENSIONS

Unit Dimensions (in)	Height	52-1/2
	Width	41-3/4
	Depth	16-3/8
Shipping Weight (lb)		255
Net Weight (lb)		224

NOTES

- Cooling and Heating Capacity data is rated at the following conditions:
Cooling: 80°FDB / 67°FWB Indoor, 95°FDB Outdoor
Heating: 70°FDB Indoor, 47°FDB / 43°FWB Outdoor

NOTE – Due to Lennox' ongoing commitment to quality, Specifications, Ratings, and Dimensions are subject to change without notice and without incurring liability. Improper installation, adjustment, alteration, service or maintenance can cause property damage or personal injury. Installation and service must be performed by a qualified installer and servicing agency.

HP-5 / CA-1 Through CA-4

Multi-Zone System Combinations

NOTE - For multi-zone systems, the total capacity of all indoor units must be 66% to 133% of the outdoor unit capacity.

Outdoor Unit Model No.	Number of Zones	Indoor Unit Capacity					Nominal Cooling Capacity at Rated System Capacity (Btuh)					Nominal Heating Capacity at Rated System Capacity (Btuh)				
		#1	#2	#3	#4	#5	#1	#2	#3	#4	#5	#1	#2	#3	#4	#5
MLB036S4M	2	6K	18K	--	---	--	6,000	18,000	--	---	--	6,400	19,100	--	---	--
		6K	24K	--	---	--	6,000	22,000	--	---	--	6,100	24,200	--	---	--
		9K	18K	--	---	--	9,000	17,000	--	---	--	9,400	18,700	--	---	--
		9K	24K	--	---	--	8,000	21,000	--	---	--	8,800	23,300	--	---	--
		12K	12K	--	---	--	12,000	12,000	--	---	--	12,800	12,800	--	---	--
		12K	18K	--	---	--	11,000	17,000	--	---	--	12,100	18,200	--	---	--
		12K	24K	--	---	--	10,000	20,000	--	---	--	11,100	22,200	--	---	--
		18K	18K	--	---	--	15,000	15,000	--	---	--	16,600	16,600	--	---	--
		18K	24K	--	---	--	13,000	18,000	--	---	--	14,500	19,300	--	---	--
	24K	24K	--	---	--	15,000	15,000	--	---	--	15,700	15,700	--	---	--	
	3	6K	6K	12K	--	---	6,500	6,500	12,900	--	---	6,800	6,800	13,600	--	---
		6K	6K	18K	--	---	6,000	6,000	18,000	--	---	6,300	6,300	18,900	--	---
		6K	6K	24K	--	---	5,500	5,500	22,000	--	---	5,800	5,800	23,200	--	---
		6K	9K	12K	--	---	6,200	9,300	12,500	--	---	6,600	9,800	13,100	--	---
		6K	9K	18K	--	---	5,700	8,600	17,200	--	---	6,100	9,100	18,100	--	---
		6K	9K	24K	--	---	5,300	7,900	21,100	--	---	5,600	8,400	22,200	--	---
		6K	12K	12K	--	---	6,000	12,000	12,000	--	---	6,300	12,600	12,600	--	---
		6K	12K	18K	--	---	5,500	11,000	16,500	--	---	5,800	11,600	17,400	--	---
		6K	12K	24K	--	---	5,000	10,000	20,100	--	---	5,300	10,600	21,200	--	---
		6K	18K	18K	--	---	5,000	15,100	15,100	--	---	5,300	15,900	15,900	--	---
		6K	18K	24K	--	---	4,500	13,600	18,100	--	---	4,800	14,400	19,200	--	---
		9K	9K	9K	--	---	9,300	9,300	9,300	--	---	9,800	9,800	9,800	--	---
		9K	9K	12K	--	---	9,000	9,000	12,000	--	---	9,500	9,500	12,600	--	---
		9K	9K	18K	--	---	8,300	8,300	16,500	--	---	8,700	8,700	17,400	--	---
		9K	9K	24K	--	---	7,500	7,500	20,100	--	---	8,000	8,000	21,200	--	---
		9K	12K	12K	--	---	8,600	11,500	11,500	--	---	9,100	12,100	12,100	--	---
		9K	12K	18K	--	---	7,900	10,500	15,800	--	---	8,400	11,100	16,700	--	---
		9K	12K	24K	--	---	7,200	9,600	19,100	--	---	7,600	10,100	20,200	--	---
		9K	18K	18K	--	---	7,200	14,300	14,300	--	---	7,600	15,200	15,200	--	---
		12K	12K	12K	--	---	11,000	11,000	11,000	--	---	11,600	11,600	11,600	--	---
	12K	12K	18K	--	---	10,000	10,000	15,100	--	---	10,600	10,600	15,900	--	---	
	12K	12K	24K	--	---	9,100	9,100	18,100	--	---	9,600	9,600	19,200	--	---	
	12K	18K	18K	--	---	9,100	13,600	13,600	--	---	9,600	14,400	14,400	--	---	
	4	6K	6K	6K	6K	--	7,200	7,200	7,200	7,200	--	7,700	7,700	7,700	7,700	--
		6K	6K	6K	9K	--	6,900	6,900	6,900	10,400	--	7,400	7,400	7,400	11,000	--
		6K	6K	6K	12K	--	6,600	6,600	6,600	13,200	--	7,000	7,000	7,000	14,000	--
		6K	6K	6K	18K	--	6,000	6,000	6,000	17,900	--	6,400	6,400	6,400	19,000	--
		6K	6K	6K	24K	--	5,300	5,300	5,300	21,400	--	5,700	5,700	5,700	22,600	--
		6K	6K	9K	9K	--	6,600	6,600	9,900	9,900	--	7,000	7,000	10,500	10,500	--
		6K	6K	9K	12K	--	6,300	6,300	9,400	12,600	--	6,700	6,700	10,000	13,300	--
		6K	6K	9K	18K	--	5,700	5,700	8,500	17,000	--	6,000	6,000	9,000	18,000	--
		6K	6K	9K	24K	--	5,000	5,000	7,500	20,100	--	5,300	5,300	8,000	21,200	--
		6K	6K	12K	12K	--	6,000	6,000	12,000	12,000	--	6,400	6,400	12,700	12,700	--
		6K	6K	12K	18K	--	5,300	5,300	10,700	16,000	--	5,700	5,700	11,300	17,000	--
		6K	6K	12K	24K	--	4,700	4,700	9,400	18,900	--	5,000	5,000	10,000	19,900	--
		6K	9K	9K	9K	--	6,300	9,400	9,400	9,400	--	6,700	10,000	10,000	10,000	--
		6K	9K	9K	12K	--	6,000	9,000	9,000	12,000	--	6,400	9,500	9,500	12,700	--
		6K	9K	9K	18K	--	5,300	8,000	8,000	16,000	--	5,700	8,500	8,500	17,000	--
6K		9K	9K	24K	--	4,700	7,100	7,100	18,900	--	5,000	7,500	7,500	19,900	--	
6K		9K	12K	12K	--	5,700	8,500	11,300	11,300	--	6,000	9,000	12,000	12,000	--	
6K		9K	12K	18K	--	5,000	7,500	10,100	15,100	--	5,300	8,000	10,600	15,900	--	
6K		12K	12K	12K	--	5,300	10,700	10,700	10,700	--	5,700	11,300	11,300	11,300	--	
6K		12K	12K	18K	--	4,700	9,400	9,400	14,100	--	5,000	10,000	10,000	14,900	--	
9K		9K	9K	9K	--	9,000	9,000	9,000	9,000	--	9,500	9,500	9,500	9,500	--	
9K		9K	9K	12K	--	8,500	8,500	8,500	11,300	--	9,000	9,000	9,000	12,000	--	
9K		9K	9K	18K	--	7,500	7,500	7,500	15,100	--	8,000	8,000	8,000	15,900	--	
9K		9K	12K	12K	--	8,000	8,000	10,700	10,700	--	8,500	8,500	11,300	11,300	--	
9K	9K	12K	18K	--	7,100	7,100	9,400	14,100	--	7,500	7,500	10,000	14,900	--		
9K	12K	12K	12K	--	7,500	10,100	10,100	10,100	--	8,000	10,600	10,600	10,600	--		
12K	12K	12K	12K	--	9,400	9,400	9,400	9,400	--	10,000	10,000	10,000	10,000	--		

NOTE - Due to Lennox' ongoing commitment to quality, Specifications, Ratings, and Dimensions are subject to change without notice and without incurring liability. Improper installation, adjustment, alteration, service or maintenance can cause property damage or personal injury. Installation and service must be performed by a qualified installer and servicing agency.

HP-5 / CA-1 Through CA-4



SUBMITTAL DATA – OUTDOOR UNIT MLB036S4M-1P MULTI-ZONE MINI-SPLIT HEAT PUMP

OUTDOOR DIMENSIONAL DRAWINGS - INCHES (MM)

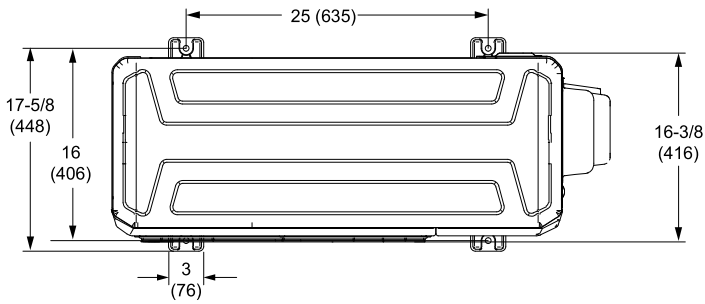

TOP VIEW

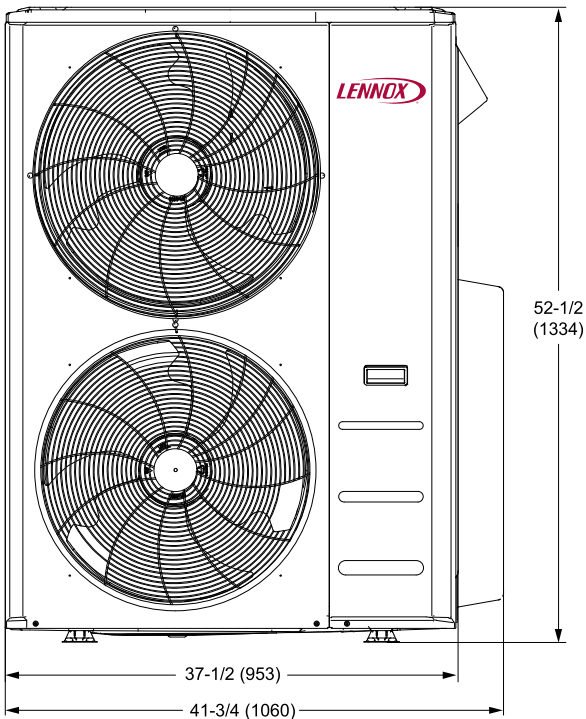

FRONT VIEW

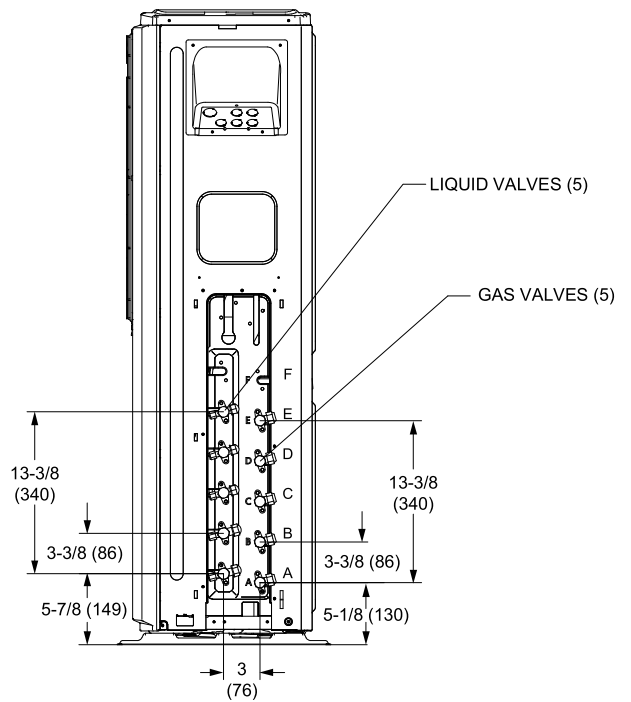

SIDE VIEW

NOTE – Due to Lennox' ongoing commitment to quality, Specifications, Ratings, and Dimensions are subject to change without notice and without incurring liability. Improper installation, adjustment, alteration, service or maintenance can cause property damage or personal injury. Installation and service must be performed by a qualified installer and servicing agency.

HP-5 / CA-1 Through CA-4



SUBMITTAL DATA – WALL-MOUNTED MVMC009S4-1P

MULTI-ZONE MINI-SPLIT HEAT PUMP

Job: _____
 Location: _____
 Schedule No.: _____
 System Designation: _____

Engineer: _____
 Architect: _____
 Date: _____
 For: Reference Approval Review Construction

FEATURES

- Pre Heat Function
- Multi-Refrigerant Outlet
- Auto Restart
- Three Speed Fan
- Flare Connections
- Refrigerant R-410A
- LED Readout Panel
- Wireless Remote Controller included

Product Warranty

All covered components - Twelve year limited warranty.
 Product registration required.

SPECIFICATIONS

PERFORMANCE

Cooling Capacity ¹ (Btu/h)		9,000
Heating Capacity ¹ (Btu/h)		9,000
Airflow (CFM)	High	335
	Medium	230
	Low	176
External Static Pressure (in. w.g.)		-
Sound Pressure (dBA)	High	38.0
	Medium	34.0
	Low	23.0

ELECTRICAL DATA

Power Supply (V/Hz/Φ)	208-230/60/1
Rated load amps (RLA)	0.25
Power Output (W)	20

DIMENSIONS

Unit Dimensions (in)	Height	11-3/4
	Width	33-3/8
	Depth	9
Liquid Pipe Connection (in)		1/4
Gas Pipe Connection (in)		3/8
Condensate drain connection (in)		1
Unit Shipping Weight (lb)		29
Unit Net Weight (lb)		23

Units must have outside air capabilities. See schedule on M302

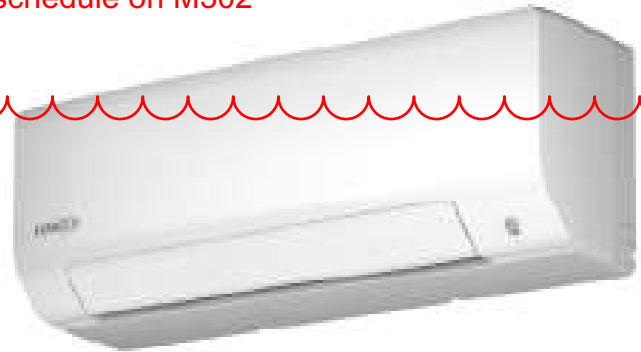

OPTIONAL ACCESSORIES

Non-Programmable Controller (M0STAT61Q-1):	
Wireless Remote Controller (RG10L-WM):	1+
Programmable Controller (M0STAT64Q-1):	

NOTES

- Cooling and Heating capacity data is rated at the following conditions:
 Cooling: 80°FDB / 67°FWB Indoor, 95°FDB Outdoor
 Heating: 70°FDB Indoor, 47°FDB / 43°FWB Outdoor



NOTE – Due to Lennox' ongoing commitment to quality, Specifications, Ratings and Dimensions subject to change without notice and without incurring liability. Improper installation, adjustment, alteration, service or maintenance can cause property damage or personal injury. Installation and service must be performed by a qualified installer and servicing agency.

HP-5 / CA-1 Through CA-4



SUBMITTAL DATA – WALL-MOUNTED MWMC009S4-1P MULTI-ZONE MINI-SPLIT HEAT PUMP

DIMENSIONAL DRAWINGS - INCHES (MM)

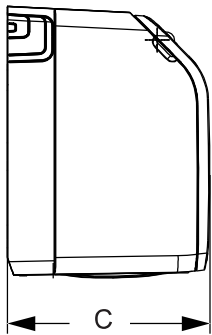

SIDE VIEW

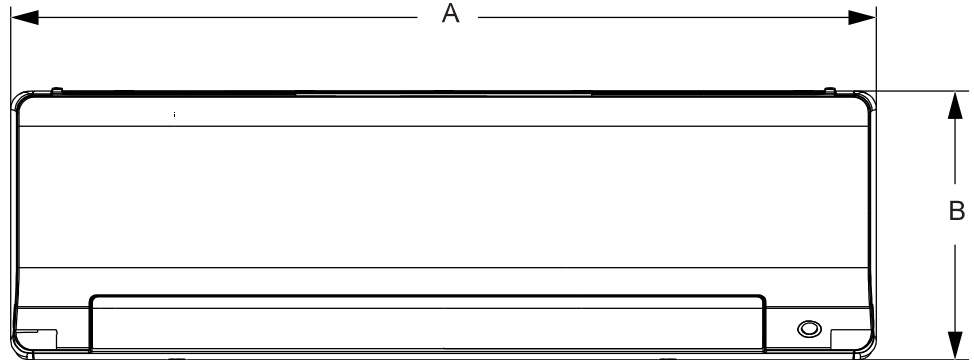

FRONT VIEW

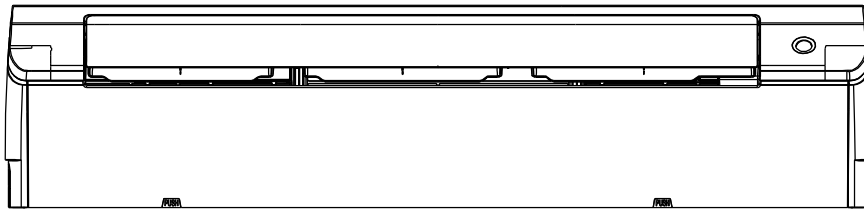

BOTTOM VIEW

Size	A		B		C	
	in.	mm	in.	mm	in.	mm
MWMC009, 012	33-3/8	848	11-3/4	298	9	229
MWMC018	40	1016	12-1/2	318	9-1/2	241
MWMC024, 030	46-7/8	1191	14-5/8	371	11	279

NOTE – Due to Lennox' ongoing commitment to quality. Specifications, Ratings and Dimensions subject to change without notice and without incurring liability. Improper installation, adjustment, alteration, service or maintenance can cause property damage or personal injury. Installation and service must be performed by a qualified installer and servicing agency.



SUBMITTAL DATA - CONTROLS

M0STAT64Q-2

MINI-SPLIT HEAT PUMP

Job: _____

Location: _____

Schedule No.: _____

System Designation: _____

Engineer: _____

Architect: _____

Date: _____

For: Reference Approval Review Construction

Programmable Controller

FEATURES AND FUNCTIONS

- Simple, user-friendly design with large backlit display for easy viewing
- Operation – On/Off
- Operation Mode – Cool/Heat/Fan/Dry/Auto
- Fan Speed – Low/Medium/High/Auto
- Programmable Schedule
 - Up to 8 events per day with unique daily schedules
 - Scheduled events include option for mode, setpoint, and fan speed
 - Copy/paste function for easy schedule programming
- Timer operation for turning indoor unit on/off in scheduled increments
- Option to sense temperature from controller using “Follow me” function
- °F or °C field selectable – default °F
- Built-in system diagnostics

SPECIFICATIONS

PERFORMANCE

Input Voltage (V)	5 VDC
Communication Cabling	Factory 4-wire harness
Setpoint Range	62°F ~ 86°F
Operating Temperature Range	23°F ~ 110°F
Operating Humidity Range (RH)	40% ~ 90%



DISPLAY

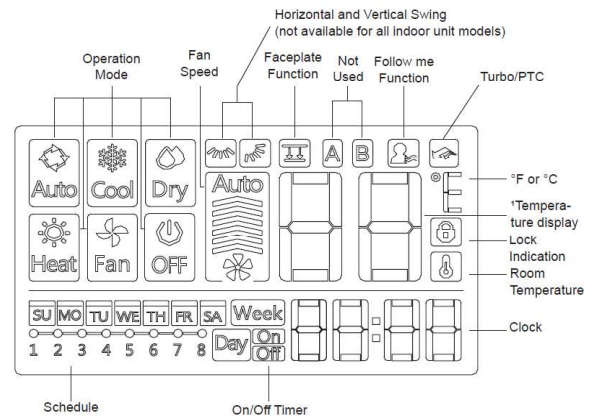

* Displays cooling setpoint, heating setpoint or room temperature

NOTE – Due to Lennox’ ongoing commitment to quality, Specifications, Ratings, and Dimensions are subject to change without notice and without incurring liability. Improper installation, adjustment, alteration, service or maintenance can cause property damage or personal injury. Installation and service must be performed by a qualified installer and servicing agency.



SUBMITTAL DATA

Submittal for:

Lakeview Animal Hospital

Contents:

GRILLES AND DIFFUSERS

FLEX AND TAPS

FANS

LOUVERS

ELECTRIC HEATERS

Mechanical Contractor:

Tennessee Mechanical

Submitted by: Hoffman & Hoffman (Knoxville)

Curtis Bixler

Date: 8/18/23

APPROVAL REQUIRED

HOFFMAN • HOFFMAN, INC.

HVAC Manufacturers Representative

Website: www.hoffman-hoffman.com

We have exercised care in the preparation of this submittal. We believe it satisfies our interpretation of the designer's intent and scope. It contains the list of materials, quantities, sizes, style and the finish as we propose to furnish for this job. Please examine and check carefully that all items are exactly as required and that our interpretation of the applicable plans and/or specifications are consistent with the design. **Approval by the engineer and purchaser will be required before release of this product for production.** If any discrepancies are discovered, please notify us as soon as possible.

Asheville, NC	(828) 296-0111	Charleston, SC	(843) 884-3201
Charlotte, NC	(704) 364-4700	Columbia, SC	(803) 765-9360
Raleigh, NC	(919) 781-8011	Greenville, SC	(864) 676-1888
Wilmington, NC	(910) 791-4775	Chesapeake, VA	(757) 548-1700
Chattanooga, TN	(423) 693-2890	Richmond, VA	(804) 272-1500
Knoxville, TN	(865) 450-9770	Roanoke, VA	(540) 725-8701

Corporate: Greensboro, NC (336) 292-8777

GRILLES, REGISTERS, AND DIFFUSERS



Grilles/Registers/Diffusers Submittals

Job Name: LAKEWAY ANIMAL HOSPITAL
Job Location: Knoxville, TN
Customer: TN Mechanical
Date Printed: 8/17/2023
Spec Section: 15 - HVAC

Contact: 408 ERIN DRIVE
KNOXVILLE, TN 37919

PRICE[®] All-In-One

Detailed Submittal Schedule

Grilles/Registers/Diffusers

#	Qty	Model	Unit Size	Border	Face Size	Finish
1	9	PDDR		3	6, 24x24	B12
3 - T-Bar Lay-in for 15/16 in. Flat Tee 6 - 6" (152mm) B12 - Standard White						
2	3	PDDR		3	8, 24x24	B12
3 - T-Bar Lay-in for 15/16 in. Flat Tee 8 - 8" (203mm) B12 - Standard White						
3	1	PDDR		3	12, 24x24	B12
3 - T-Bar Lay-in for 15/16 in. Flat Tee 12 - 12" (305mm) B12 - Standard						
4	1	PDDR		1	6x6, 12x12	B12
1 - Flat Frame for Surface Mounting 6x6 - 6" x 6" (152mm x 152mm) B12 -						
5	7	PDDR		3	6, 24x24	B12
3 - T-Bar Lay-in for 15/16 in. Flat Tee 6 - 6" (152mm) B12 - Standard White						
6	1	PDDR		3	8, 24x24	B12
3 - T-Bar Lay-in for 15/16 in. Flat Tee 8 - 8" (203mm) B12 - Standard White						
7	1	PDDR		3	10, 24x24	B12
3 - T-Bar Lay-in for 15/16 in. Flat Tee 10 - 10" (254mm) B12 - Standard						
8	2	PDDR		3	12, 24x24	B12
3 - T-Bar Lay-in for 15/16 in. Flat Tee 12 - 12" (305mm) B12 - Standard						
9	1	635	8.000, 6.000	F		B12
F - 1 1/4" (32) Flat Frame Standard B12 - Standard White						
10	37	SCD	6	31	24, 24	B12
31 - 15/16" T-Bar Lay-In and Surface Mount Application B12 - Standard White						
11	3	SCD	8	31	24, 24	B12
31 - 15/16" T-Bar Lay-In and Surface Mount Application B12 - Standard White						
12	1	920	12.000, 8.000	F		B12
F - 1 1/4" (32) Flat Frame B12 - Standard White						
13	1	920	12.000, 6.000	F		B12
F - 1 1/4" (32) Flat Frame B12 - Standard White						



Performance Notes

Date Printed: 8/17/2023

1. Tested in accordance with ASHRAE Standard 70-2006 "Method of Testing for Rating the Performance of Air Outlets and Inlets".
2. Throw data is based on the temperature differential (Dt), in degrees Fahrenheit (°F), between supply air temperature and room temperature.
3. Throw values, in feet (ft), are provided at terminal air velocities of 150 fpm, 100 fpm, and 50 fpm for supply applications.
4. The NC, sound pressure level, is based on a room absorption of 10dB re 10⁻¹² Watts in each octave band.
5. Blanks (--) indicate an NC level below 15.
6. Air flow is in cubic feet per minute (cfm).
7. Static pressure (Ps), velocity pressure (Pv), and total pressure (Pt) are in inches of water (in. w.g.).

PDDR Perforated Return Diffuser

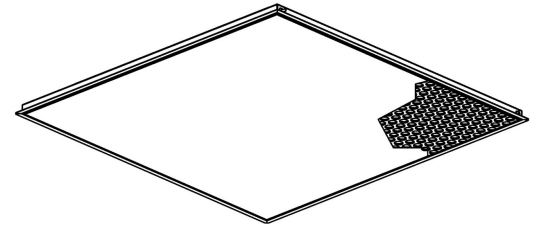
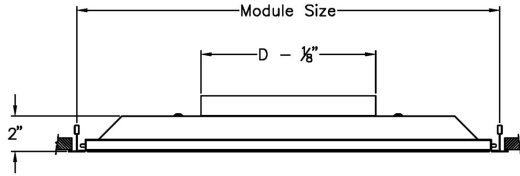

Module Size: 24"x24"
Inlet Size: 6" round

Frame Style: 3 - 15/16" T-Bar Lay-In

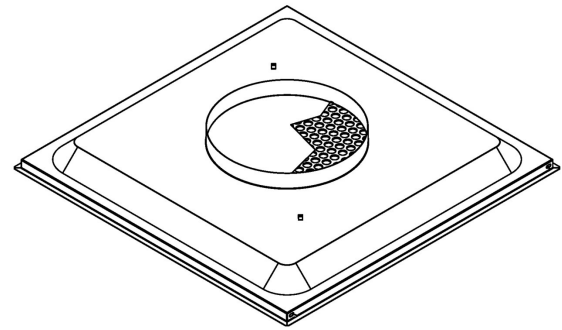
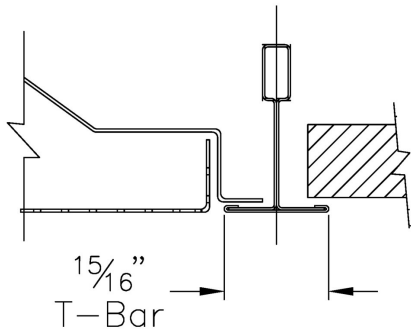

Finish

- B12 - Standard White

Notes

- Face panel is removable
- Integral hanger loops
- Factory tolerance +/- 1/32"

Construction

- Perforated face - 3/16" holes, 51% free area
- F-ST - Steel face
- Steel backpan and outer frame
- Steel spring latches



Scan for link to additional product information

PROJECT: LAKEWAY ANIMAL HOSPITAL
ENGINEER:
DESCRIPTION: Perforated Return Diffuser
PDDR-1-2//I/IN/RD/6//24x24/3/F-ST/PL-ST/A/////B12

SUBMITTAL NO: 271091-A
CUSTOMER: TN Mechanical

SUBMITTAL DATE: 8/17/2023

PDDR Perforated Return Diffuser

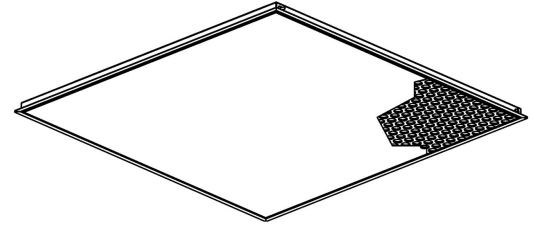
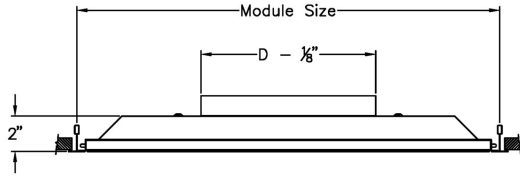

Module Size: 24"x24"
Inlet Size: 8" round

Frame Style: 3 - 15/16" T-Bar Lay-In

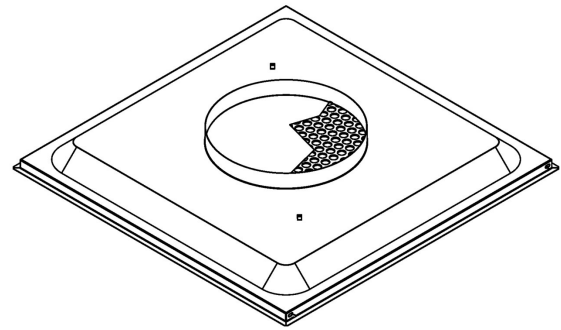
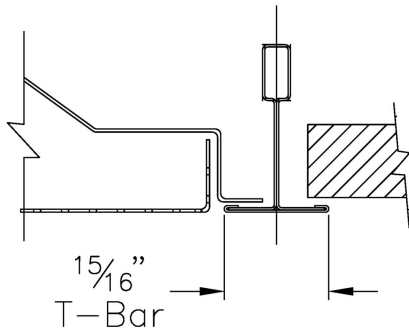

Finish

- B12 - Standard White

Notes

- Face panel is removable
- Integral hanger loops
- Factory tolerance +/- 1/32"

Construction

- Perforated face - 3/16" holes, 51% free area
- F-ST - Steel face
- Steel backpan and outer frame
- Steel spring latches



Scan for link to additional product information

PROJECT: LAKEWAY ANIMAL HOSPITAL
ENGINEER:
DESCRIPTION: Perforated Return Diffuser
PDDR-1-2//I/IN/RD/8//24x24/3/F-ST/PL-ST/A/////B12

SUBMITTAL NO: 271091-A
CUSTOMER: TN Mechanical

SUBMITTAL DATE: 8/17/2023

PDDR Perforated Return Diffuser

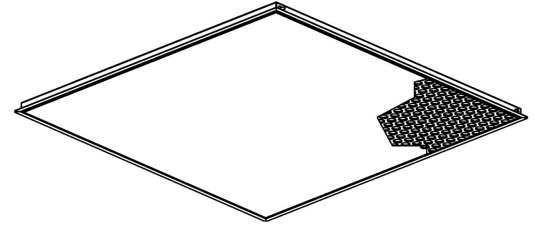
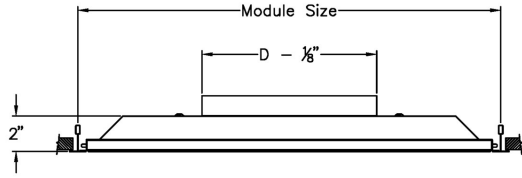

Module Size: 24"x24"
Inlet Size: 12" round

Frame Style: 3 - 15/16" T-Bar Lay-In

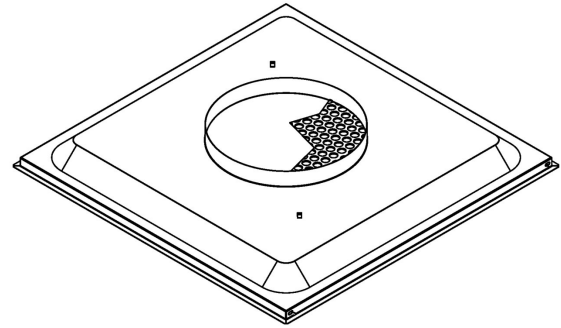
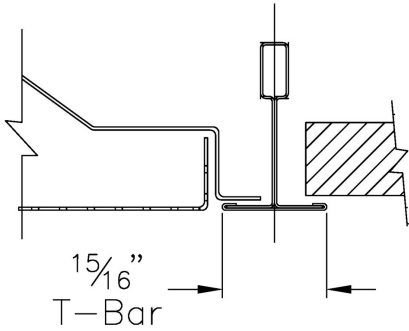

Finish

- B12 - Standard White

Notes

- Face panel is removable
- Integral hanger loops
- Factory tolerance +/- 1/32"

Construction

- Perforated face - 3/16" holes, 51% free area
- F-ST - Steel face
- Steel backpan and outer frame
- Steel spring latches



Scan for link to additional product information

PROJECT: LAKEWAY ANIMAL HOSPITAL
ENGINEER:
DESCRIPTION: Perforated Return Diffuser
PDDR-1-2//I/IN/RD/12//24x24/3/F-ST/PL-ST/A/////B12

SUBMITTAL NO: 271091-A
CUSTOMER: TN Mechanical

SUBMITTAL DATE: 8/17/2023

PDDR Perforated Return Diffuser

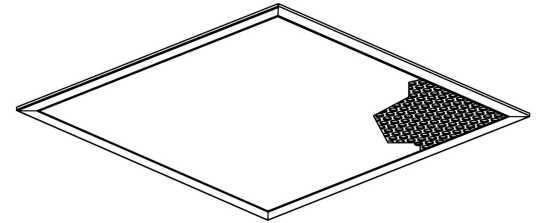
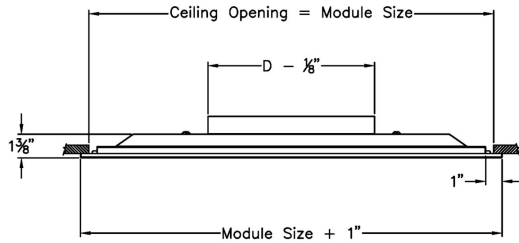

Module Size: 12"x12"
Inlet Size: 6"x6"

Frame Style: 1 - Surface mount

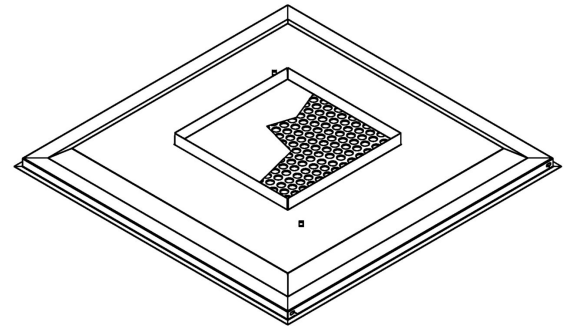
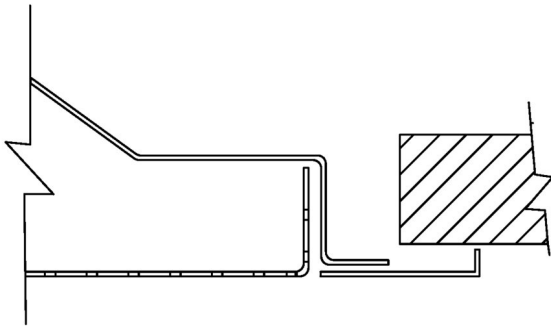

Finish
• B12 - Standard White

Notes

- Face panel is removable
- Integral hanger loops
- Factory tolerance +/- 1/32"

Construction

- Perforated face - 3/16" holes, 51% free area
- F-ST - Steel face
- Steel backpan and outer frame
- Steel spring latches



Scan for link to additional product information

PROJECT: LAKEWAY ANIMAL HOSPITAL
ENGINEER:
DESCRIPTION: Perforated Return Diffuser
PDDR-1-2//1IN/SQ/6x6//12x12/1/F-ST/PL-ST/B/////B12

SUBMITTAL NO: 271091-A
CUSTOMER: TN Mechanical

SUBMITTAL DATE: 8/17/2023

PDDR Perforated Return Diffuser

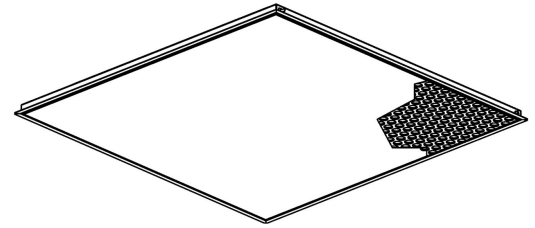
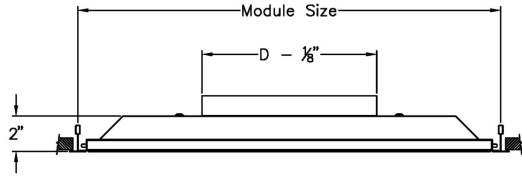

Module Size: 24"x24"
Inlet Size: 10" round

Frame Style: 3 - 15/16" T-Bar Lay-In

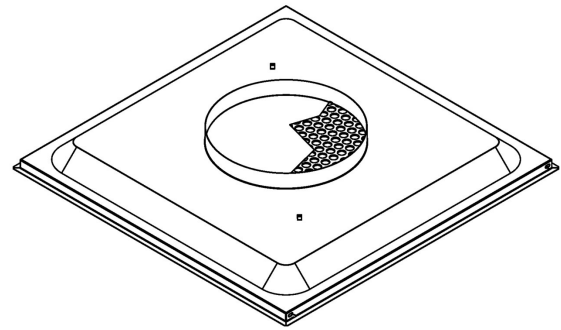
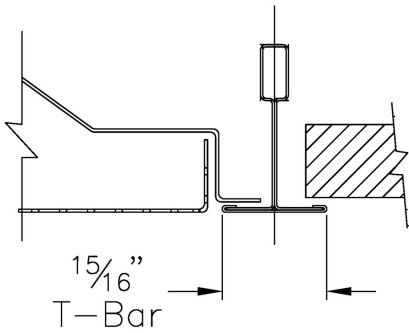

Finish

- B12 - Standard White

Notes

- Face panel is removable
- Integral hanger loops
- Factory tolerance +/- 1/32"

Construction

- Perforated face - 3/16" holes, 51% free area
- F-ST - Steel face
- Steel backpan and outer frame
- Steel spring latches



Scan for link to additional product information

PROJECT: LAKEWAY ANIMAL HOSPITAL
ENGINEER:
DESCRIPTION: Perforated Return Diffuser
PDDR-1-2//I/IN/RD/10//24x24/3/F-ST/PL-ST/A/////B12

SUBMITTAL NO: 271091-A
CUSTOMER: TN Mechanical

SUBMITTAL DATE: 8/17/2023

635-1-2 Alum Return Grille, 45deg Blades, 1/2" Spacing

Core Style:

Single Deflection

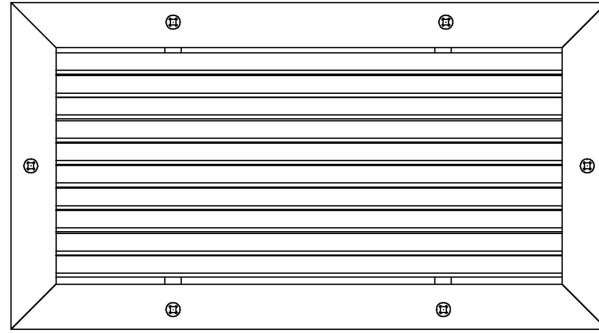
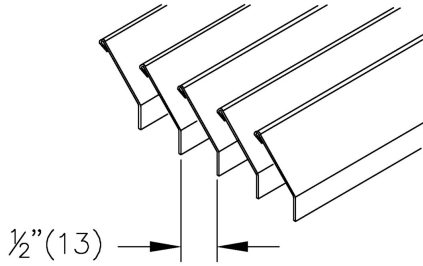

Fastening:

A: Countersunk Screwholes c/w Screws

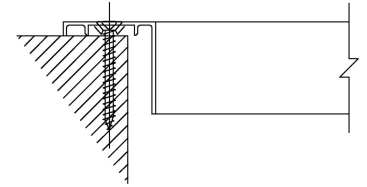

Border: F 1 1/4" (32) Flat Frame Standard

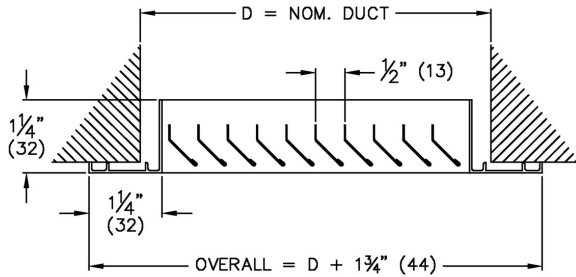

Material:

- Aluminum

Finish:

- B12 - Standard White

Notes:

- Blades parallel to Long dimension
- 45° Deflection roll formed blades on 1/2" (13) centers
- Factory tolerance $\pm 1/32"$ (1)
- Mullions are included when blades are parallel to nominal size dimension larger than 8" (203).

PROJECT: LAKEWAY ANIMAL HOSPITAL
ENGINEER:
DESCRIPTION: Alum Return Grille, 45deg Blades, 1/2" Spacing
635-1-2//1/8.000/6.000/SM/F///L/A///B12

SUBMITTAL NO: 269136
CUSTOMER: TN Mechanical

SUBMITTAL DATE: 8/17/2023

SCD Square Cone Diffuser

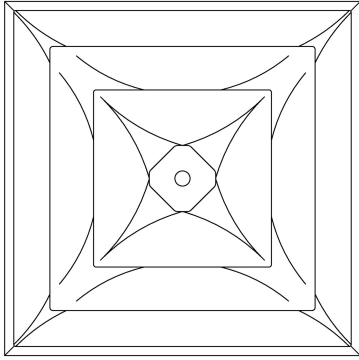

- Duct Diameter:** 6"
- Backpan Height (B):** 2 1/2"
- Cone Depth (C):** 1 1/16"
- Ceiling Module:** 24" x24"
- Ceiling Opening (Surface Mount):** 22" x 22"
- No. of Cones:** 3 Cones

Border: 31

15/16" T-Bar Lay-In or Surface Mount Application

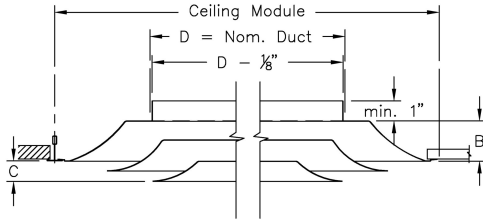

Frame Detail:

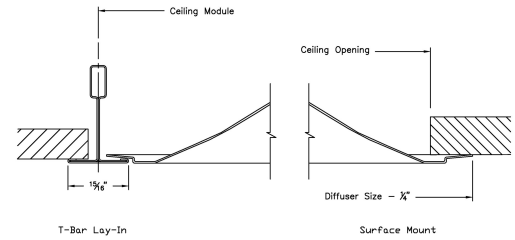

Notes:

- 360° radial horizontal air pattern
- Fixed core with removable plug button. For surface mount installation, use of a plaster frame is recommended.
- For 9/16" flat tee installation with style 31 frame, cross-tees must be firmly secured. Locking any unopposed cross tees to the main beam with clips such as Armstrong STAC is recommended. Corner clips from ceiling suppliers may also be used, or order 916 clip in GRD-PARTS (confirming fit with ceiling on site is recommended).
- Integral hanger loops
- Factory tolerance +/- 1/32"

Material:

- Diffuser: Steel

Finish:

- B12 - Standard White



Scan for link to additional product information

PROJECT: LAKEWAY ANIMAL HOSPITAL
ENGINEER:
DESCRIPTION: Square Cone Diffuser
SCD-1-2//1/6//24/24/31//3C/FC/////B12

SUBMITTAL NO: 258274-F
CUSTOMER: TN Mechanical

SUBMITTAL DATE: 8/17/2023

SCD Square Cone Diffuser

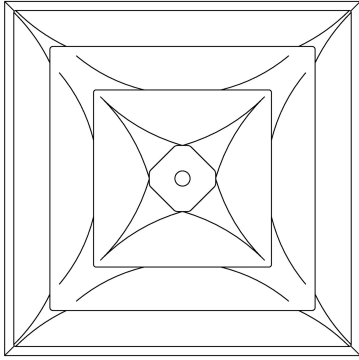

- Duct Diameter:** 8"
- Backpan Height (B):** 2 1/2"
- Cone Depth (C):** 1 1/16"
- Ceiling Module:** 24" x24"
- Ceiling Opening (Surface Mount):** 22" x 22"
- No. of Cones:** 3 Cones

Border: 31

15/16" T-Bar Lay-In or Surface Mount Application

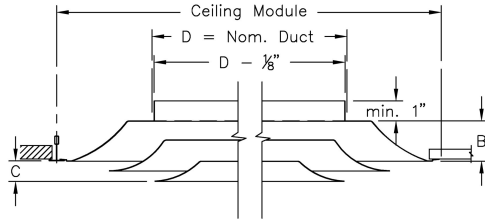

Frame Detail:

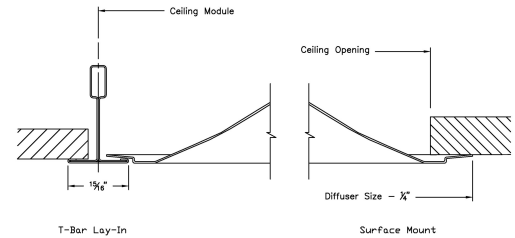

Notes:

- 360° radial horizontal air pattern
- Fixed core with removable plug button. For surface mount installation, use of a plaster frame is recommended.
- For 9/16" flat tee installation with style 31 frame, cross-tees must be firmly secured. Locking any unopposed cross tees to the main beam with clips such as Armstrong STAC is recommended. Corner clips from ceiling suppliers may also be used, or order 916 clip in GRD-PARTS (confirming fit with ceiling on site is recommended).
- Integral hanger loops
- Factory tolerance +/- 1/32"

Material:

- Diffuser: Steel

Finish:

- B12 - Standard White



Scan for link to additional product information

PROJECT: LAKEWAY ANIMAL HOSPITAL
ENGINEER:
DESCRIPTION: Square Cone Diffuser
SCD-1-2//1/8//24/24/31//3C/FC/////B12

SUBMITTAL NO: 258274-F
CUSTOMER: TN Mechanical

SUBMITTAL DATE: 8/17/2023

920 Heavy Duty Steel Gymnasium Grille - 1/2" Blade Spacing, Double Deflection

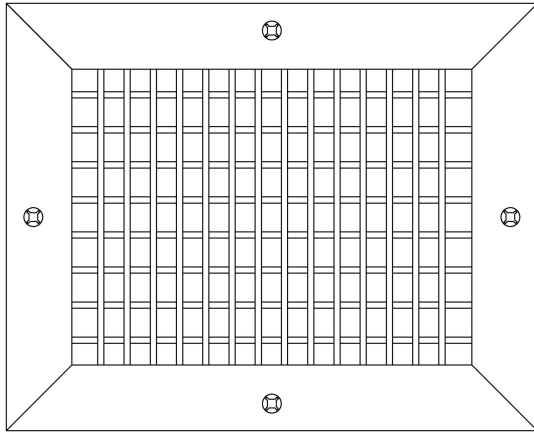

Fastening:

A: Countersunk screwholes with standard screws

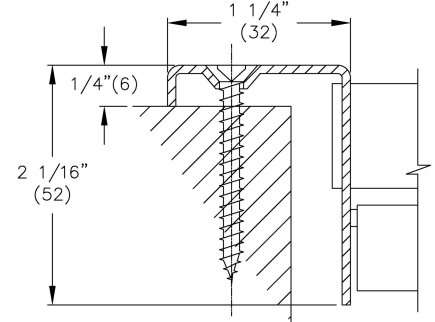

Border: F
1 1/4" (32) Flat Frame

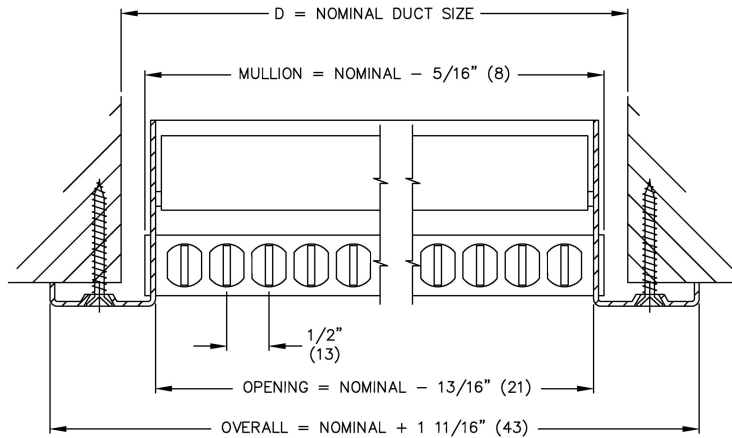

Notes:

- Front blades are parallel to the short dimension
- Blades are individually adjustable, up to 45° in either direction
- One blade fixed at 0° deflection approximately every 12" (305)
- 1/2" (13) front blade spacing
- 3/4" (19) rear blade spacing
- Factory tolerance: ± 1/32"(1)

Material:

- Frame: 16 GA CRS
- Front Deflection Blades: 14 GA CRS
- Rear Deflection Blades: 24 GA CRS
- Mullions: 14 GA CRS

Finish:

- B12: Standard White

PROJECT: LAKEWAY ANIMAL HOSPITAL
ENGINEER:
DESCRIPTION: Steel Double Deflection Gym Grille
920///12.000/8.000,6.000/F/S///A//B12

SUBMITTAL NO: 261096-C
CUSTOMER: TN Mechanical

SUBMITTAL DATE: 8/17/2023

FLEXIBLE DUCT AND TAKEOFFS



MHP-25

R4.2, R6 & R8

Insulated Class 1 Flexible Air Duct

JPL strives to be the best flexible ductwork manufacturer in the United States

JPL's process is state of the art, yielding the highest quality product on the market

MHP series is a UL listed and labeled Class 1 flexible air duct, used in the HVAC industry as a supply and return air duct in low to medium pressure duct systems. MHP is made in 25', 45', and 50' lengths.

Physical Description

MHP-25 (25' length) flexible duct is constructed with a spring steel wire helix, encapsulated in a 2-ply, air-tight inner core. Fiberglass insulation choices of R4.2, R6 & R8 encompass the core and a unique metalized, reinforced vapor barrier surrounds the entire duct.

Product Data

Diameter: 4", 5", 6", 7", 8", 9", 10", 12", 14", 16", 18", 20", 22"

Note: 22" available in MHP-25 R6 only.

Length: 25 feet

Packaging: 1 section per polybag or carton. To meet thermal properties, packaging complies with recommended 12:1 or less compression ratio.

Vapor Barrier: 2-Ply Reinforced Metalized Polyester.

End Treatments: Raw Ended

Inner Core: Airtight 2-Ply Black Pigmented Polyester

Features & Benefits

UL Listed & Labeled

Guaranteed out of package lengths

10 Year limited warranty

GREENGUARD Gold Certification

Formaldehyde Free (see www.jplflex.com for more info)

3/8 Oversized core

Certified R-Values

Contact Us!

1-800-255-FLEX (3539)

www.jplflex.com



Performance Data

Thermal Value: R4.2, R6 & R8 Classified by Underwriters Laboratories, Inc. and bears the ADC Thermal Certification Mark

Maximum Positive Pressure: 6" W.G. (4" - 12"), 4" W.G. (14" - 22") determined per ADC Test FD-72R1 at 180° F temperatures in a 90° elbow

Maximum Negative Pressure: 1" W.G. (4" - 10"), 1/2" W.G. (12" - 22")

Vapor Barrier: Flexible air ducts are for indoor applications and should not be exposed to direct ultraviolet light

Maximum Velocity: 5,000 FPM.

Operating Temperature: -20°F to 140°F Continuous, -20°F to 200°F Intermittent.

Permeance: (Vapor - Barrier) .13 US Perms per ASTM E96A - 94.

Code Compliance & Approvals

Listed & Labeled Underwriters Laboratories, Inc. File # MH11637

UL-181 Class 1 Air Duct

Flame Spread 25 or Less

Smoke Developed 50 or Less.

Meets the requirements of NFPA 90A & 90B

UMC & IMC and most model codes.

California Insulation Manufacturer #TD-1092.

JP Lamborn Company - Plants in California, Colorado, Florida & Tennessee



@JPLambornCo



@JPLambornCo



JPLambornCo



MHP-25

R4.2, R6 & R8

Insulated Class 1
Flexible Air Duct

JPL provides consistent performance - all at a fair price and unbeatable quality since 1961.

JPL flex duct is the best in the business. JPL summed up in a single word - Trust.

Air Friction Loss Data

- Specifications subject to change without notice. -

Proper use and installation of these products shall be in accordance with UL-181 and ADC recommended installation instructions in each package.

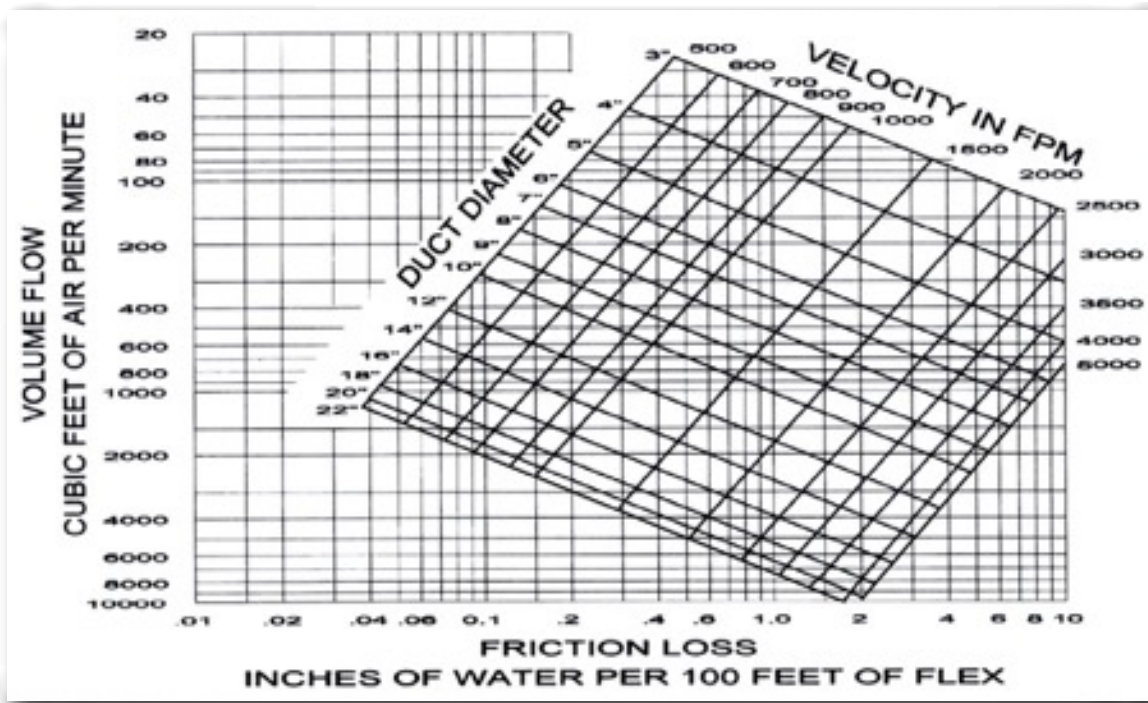

Ten Year Limited Warranty

JP Lamborn Company warrants that all of its UL-181 Flexible Air Ducts (the 'Product') will be free from defects in materials and workmanship under normal use for a period of ten (10) years from date of manufacture. This warranty shall apply only to the Product when installed in the U.S.A. in accordance with JP Lamborn Company's written installation instructions and within the conditions and limitations of the published performance data.



Download:

[10 Year Warranty](#)

Contact JP Lamborn

JP Lamborn Co.
1-800-255-FLEX (3539)
jplsales@jplflex.com
www.jplflex.com





MODEL #

AT-502

DESCRIPTION:
 AIR TIGHT 45° TAKEOFF W/
 GASKET, DAMPER & 2"
 STANDOFF QUADRANT & 1/4"
 HARDWARE.

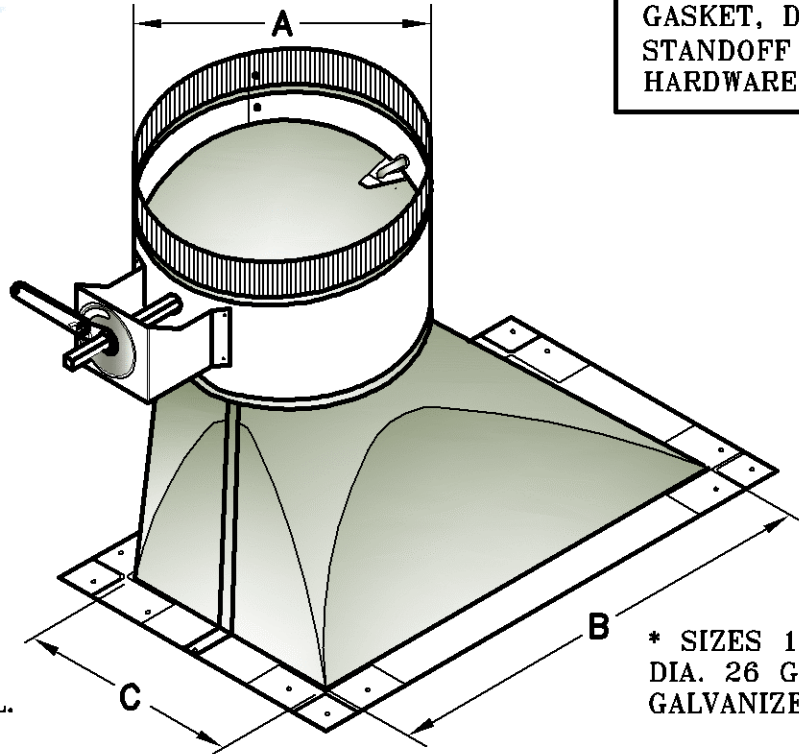

* SIZES 4" THROUGH 9"
 DIA. 28 GAUGE
 GALVANIZED SHEET METAL.

* SIZES 10" THROUGH 20"
 DIA. 26 GAUGE
 GALVANIZED SHEET METAL.

PRODUCT NOTES:	SIZES AVAILABLE:			
<p>TAKEOFF FITTINGS ARE CONSTRUCTED OF GALVANIZED SHEET METAL OF LOCK FORMING AND ROLL FORMING QUALITY.</p> <p>THE 1" WIDE MOUNTING FLANGES COME COMPLETE WITH DIE FORMED CORNER CLIPS FOR ADDED RIGIDITY AND PRE-PUNCHED SCREW HOLES.</p> <p>A PEEL OFF ADHESIVE GASKET (1" X 1/8") IS PROVIDED BY THE FACTORY TO HOLD THE FITTING SECURELY IN PLACE DURING INSTALLATION AND TO ASSURE MINIMAL LEAKAGE.</p> <p>DAMPER BLADE CAN BE CONSTRUCTED WITH 28, 26, 24 OR 22 GAUGE MATERIAL.</p>	A	B	C	HEIGHT
	4"	8"	6"	10"
	5"	10"	5"	10"
	6"	12"	6"	10"
	7"	12"	6"	10.25"
	8"	12"	6"	10.25"
	9"	15"	6"	10.25"
	10"	16"	6.5"	12"
	12"	18"	8.5"	12"
	14"	20"	9.5"	13.75"
	16"	24"	12"	14.5"
	18"	26"	14"	14.5"
	20"	28"	16"	15.25"

JOB _____ DATE _____

ARCHITECT _____ REPRESENTATIVE _____

ENGINEER _____ P.O. # _____

CONTRACTOR _____

EXHAUST FANS



Submittal Data

08/18/2023

Project: LAKEWAY ANIMAL HOSPITAL

Engineer:

Architect:

Contractor:

Submitted By: Hoffman & Hoffman-Knoxville
Kevin Stopper
408 Erin Drive
Knoxville, Tennessee 37919

Project: LAKEWAY ANIMAL HOSPITAL



SUBMITTAL PACKAGE

Ceiling & Room-to-Room

Z - Ceiling/Inline Duct Mounted Cabinet Exhaust Fan

ID#	Tag	Qty
Z-1		1
Z-2		4

Note:

- Quantities and Sizes listed are for submittal purposes only, to be verified prior to order.
- Submittal information is deemed correct at time of printing, however in the interest of product improvement pennbarry reserves the right to make changes without notice.

ZJ1 - SC

Ceiling/Inline Duct Mounted Cabinet Exhaust Fan

Quantity: 1
Special: None

Dimensions

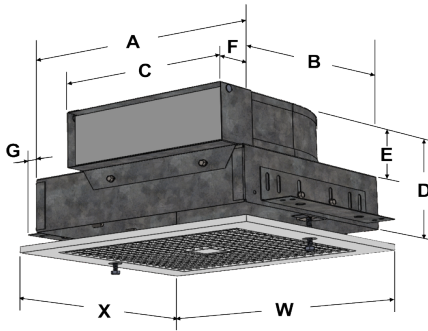

Unit Size	A	B	C	D
J1	13.74	11.92	10.02	6.55

E	F	G	W	X
3.29	1.36	1.56	14.88	13.25

Weight
15

Standard Construction Features

- Forward curved centrifugal blower
- Integral chatter proof backdraft damper
- Motor continuous duty, with thermal overload protection, positively cooled, & mounted on vibration isolators
- Fan/motor/wheel "power pack" is removable
- Corrosion resistant fasteners

Accessories

- UL / ETL Listing: 2 - UL 507
- Unit Size: J1
- Drive Type: D - Direct
- Discharge Configuration: CR - Ceiling Cavity Right Angle
- Motor Efficiency: S - Standard
- Controllers: 2 - LekTrol SS Speed Ctrlr (Loose)
- Grilles: J - Plastic Grille
- Duct Transition: S - Square to Round Transition

(continued)

Performance

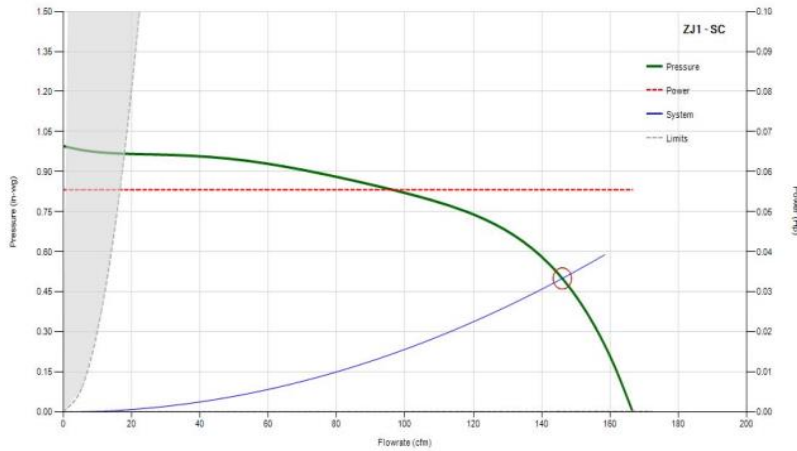

Operating Point

Volume (CFM)	146
Static Pressure (in. wg)	0.5
Fan RPM	1141
Horse Power (BHP)	0.06
Elevation (ft)	0
Temperature (°F)	0
Drive Loss (%)	N/A
FEI	118.98

Motor Information

Motor Watts	125
Volt/Ph/Hz	115V /1/ 60
Enclosure	6 - OP (Open)
NEC FLA*	1.7
Weight+ (lbs)	15

* NEC FLA - based on tables 430.248 or 430.250 of National Electrical Code 2014. Actual motor FLA may vary depending on motor manufacturer.
 + Motor weight may vary depending on supplier

SOUND POWER

OCTAVE POWER CENTER FREQUENCY (hz)

63	125	250	500	1000	2000	4000	8000
68	69	57	49	49	42	36	34

LWA	dBA	Sones
56	44.9	4.09

LwA - Weighted sound power, based on ANSI S1.4, dBA - Weighted sound pressure, based on 11.5 dB attenuation per Octave band at 5 ft. Sones - calculated using AMCA 301 at 5 ft.



Z8-GP

Ceiling/Inline Duct Mounted Cabinet Exhaust Fan

Quantity: 4
Special: None

Dimensions

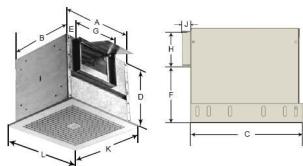

Unit Size	A	B	C	D
8	13.875	11.375	17.375	11.375

E	F	G	H	J
1.875	5.25	8	6	0.75

K	L	Weight
13.25	14.875	20

Standard Construction Features

- Galvanized housing lined with acoustical insulation
- Forward curved centrifugal blower
- Integral chatter proof backdraft damper
- Motor continuous duty, with thermal overload protection, positively cooled, & mounted on vibration isolators
- Fan/motor/wheel "power pack" is removable
- Corrosion resistant fasteners

Accessories

- UL / ETL Listing: 2 - UL 507
- Unit Size: 8
- Drive Type: D - Direct
- Discharge Configuration: CR - Ceiling Cavity Right Angle
- Motor Efficiency: G - Green Plus ECM
- Controllers: B - PWM Controller
- Grilles: J - Plastic Grille
- Duct Transition: S - Square to Round Transition

Performance

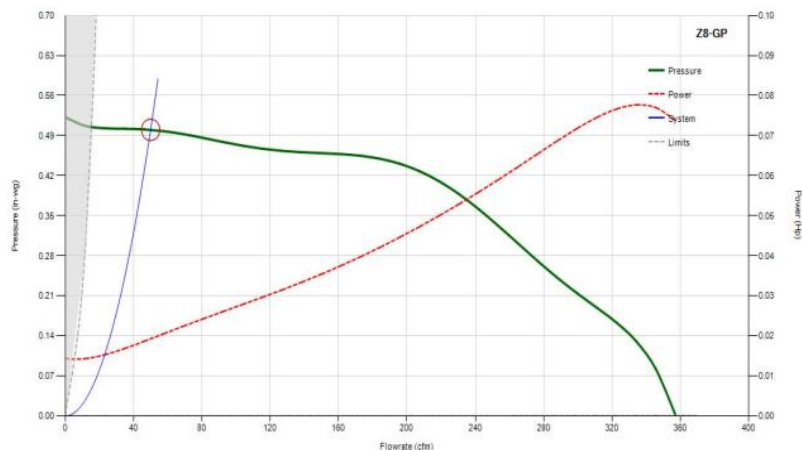

Operating Point

Volume (CFM)	50
Static Pressure (in. wg)	0.5
Fan RPM	1050
Horse Power (BHP)	0.02
Elevation (ft)	0
Temperature (°F)	0
Drive Loss (%)	N/A
FEI	131.91

Motor Information

Motor Watts	C/F
Volt/Ph/Hz	115V /1/ 60
Enclosure	3 - TEAO
NEC FLA*	C/F
Weight+ (lbs)	15

* NEC FLA - based on tables 430.248 or 430.250 of National Electrical Code 2014. Actual motor FLA may vary depending on motor manufacturer.
 + Motor weight may vary depending on supplier

(continued)

63	125	250	500	1000	2000	4000	8000
61	60	60	57	55	51	45	42

LWA	dBA	Sones
60	45.2	3.69

LwA - Weighted sound power, based on ANSI S1.4, dBA - Weighted sound pressure level, based on ANSI S1.4, 11.5 dB attenuation per Octave band at 5 ft. Sones - calculated using AMCA 301



LOUVERS



Submittal Data

8/18/2023

Project Name: LAKEWAY ANIMAL HOSPITAL

Submitted By: Curtis Bixler

Hoffman & Hoffman-Knoxville

408 Erin Drive

Knoxville, Tennessee 37919

United States



SUBMITTAL PACKAGE

Wind Driven Rain Louvers

Model: EME720 - Extruded Aluminum Stationary Wind Driven Rain Louver

ID#	Qty	Width (A)	Height (B)	Size	Frame	Screen	Sill Type	Finish Type
EME720-1	2	14	12	Deduct 1/4	FRONT FLANGE	5/8 Inch .040 ALUM	FM AL.080W/ED	BE SMP

Note:

- Quantities and Sizes listed are for submittal purposes only, to be verified prior to order.
- Submittal information is deemed correct at time of printing, however in the interest of product improvement Ruskin reserves the right to make changes without notice.

EME720

Extruded Aluminum Stationary Wind Driven Rain Louver
 7 Inch Deep - Horizontal Double Drainable Blades



CONSTRUCTION

PERFORMANCE RATINGS

Frame Material	6063-T6 Extruded alum with .080" nominal thickness
Blade Material	6063-T6 Extruded alum with .075" nominal wall thickness
Frame Type	FRONT FLANGE
Screen	5/8 Inch .040 ALUM
Screen Mtg	REAR
Sill Type	FM AL.080W/ED
Install Angles	2x2x.25x2

AMCA511	Listed
Beginning Point of Water Penetration	1105 fpm (+337 m/min).
Free Area	56%
Intake Pressure Drop	1000 fpm = 0.37"w.g.
Exhaust Pressure Drop	1000 fpm = 0.32"w.g.
Wind-Driven Rain 29MPH	2.5 m/s Intake Velocity-Class A
Windload	30 PSF

Notes:
 Pressure Drop, Water Penetration, & Free Area Test size 48" wide x 48" high (1219 x 1219)
 Wind Driven Rain Test size is 1m x 1m (39 3/8" x 39 3/8") core area, 1.05m x 1.08m (41.5" x 43.25") nominal. Free Area of test louver is 6.85 ft2 (.64m2).

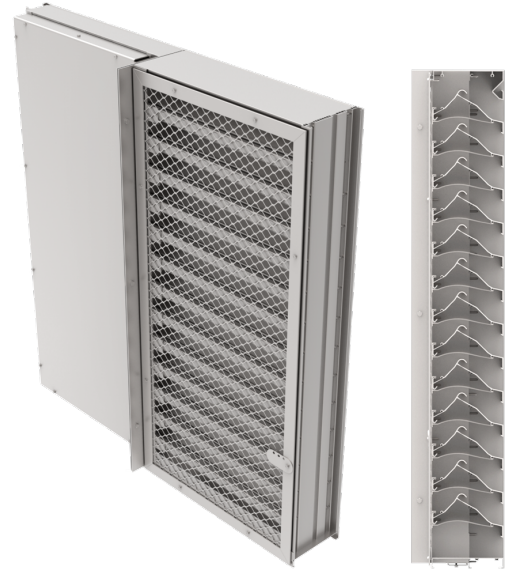

FINISH DETAILS

Finish Type	BE SMP
Finish Color	MEDIUM BRZ.(72)



SCHEDULE

ID#	Qty	Dimensions (Inches)			Frame	Sections		Screen	Sill Type	Wind Load (PSF)	Free Area (%)
		Width (A)	Height (B)	Size		Wide	High				
EME720-1	2	14	12	Deduct 1/4	FRONT FLANGE	1	1	5/8 Inch .040 ALUM	FM AL.080W/ED	30	33

ELECTRIC HEATERS



470 Beauty Spot Rd. E, Bennettsville, SC 29512



File # E21609

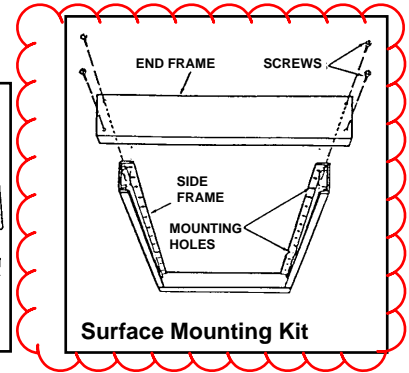
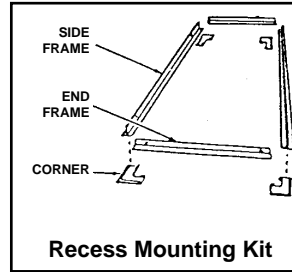
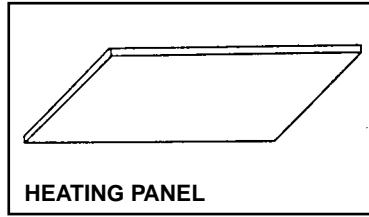

SUBMITTAL SHEET
CP SERIES
ELECTRIC RADIANT
CEILING PANELS

CP SERIES - ELECTRIC RADIANT CEILING PANELS

CEILING PANELS

TAG	QTY.	CATALOG NUMBER	SIZE	VOLTS	WATTS	CUSTOM FEATURES
RP1	1	CP751F	2560BTU	120/1	.75	

**ACCESSORIES
 AND
 CONTROLS**

TAG	QTY.	CAT. NO.	DESCRIPTION
	1	M601W	Single Pole Thermostat

DATE: 8/18/23

PROJECT: Lkeway Animal Hospital

ARCHITECT: _____

ENGINEER: _____

CONTRACTOR: _____

SUBMITTED BY: _____

STANDARD FEATURES

CUTAWAY DRAWING OF A HEATING PANEL

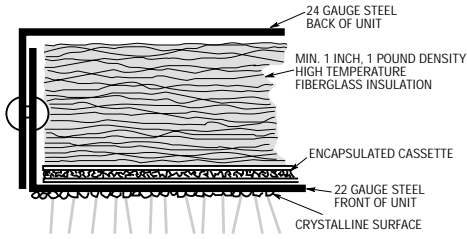

- METAL:**
 Back - 24 Gauge Galvanized or Aluminized Steel.
 Front - 22 Gauge Galvanized or Aluminized Steel.
 Sides - Overlapping Front and Back.
- WIRE:**
 Internal - 200°C, 14 Gauge, Teflon insulated.
 External - Pig Tails with 48" of 1/2" flexible conduit and connector for J-Box.
- ELEMENT:**
 The encapsulated cassette element delivers a uniform temperature distribution over entire panel surface.
- INSULATION:**
 Minimum 1 inch, 1 pound density, high temperature fiberglass.
- SURFACE:**
 All ceiling panels are coated with unique crystalline surface. Flurry white finish.

STANDARD FINISH - Standard mounting kits finished white to blend with standard panel flurry white finish.

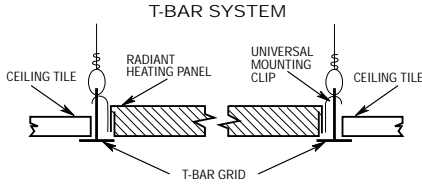
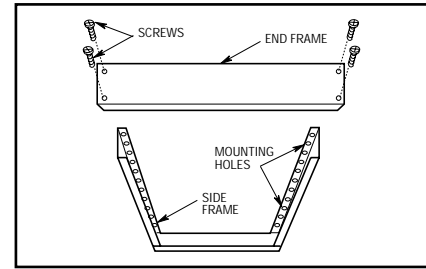

WIRING - For connection to the main power supply, the heater is completely prewired including green ground wire, with the lead wires housed in a 48-inch length of flexible metal conduit and connector for J-Box mounting.

FRAME CONSTRUCTION FOR SURFACE MOUNT PANELS

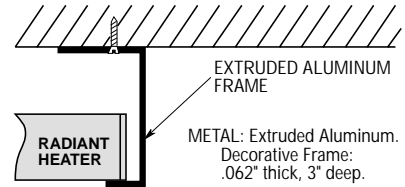

WOOD:
 Heaters can be framed in wood
 Consult your factory representative for specifics.

CAT. NO.	VOLTS	WATTS	DIM. (IN.)
CP251F	120	250	24
CP258F	208		
CP252F	240		
CP257F	277		
CP253F	347		
CP311F	120	310	24
CP318F	208		
CP312F	240		
CP317F	277		
CP313F	347		
CP371F	120	375	24
CP378F	208		
CP372F	240		
CP377F	277		
CP373F	347		
CP501F	120	500	48
CP508F	208		
CP502F	240		
CP507F	277		
CP503F	347		
CP621F	120	625	48
CP628F	208		
CP622F	240		
CP627F	277		
CP623F	347		
CP751F	120	750	48
CP758F	208		
CP752F	240		
CP757F	277		
CP753F	347		

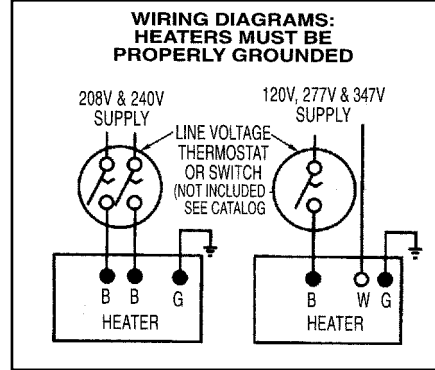

UNIVERSAL HANGING CLIPS - All radiant ceiling panels are supplied with COMBINATION EARTHQUAKE/T-BAR GRIP CLIPS as a standard feature. These clips have holes for support chains or can be folded over the T-BAR to reduce lateral movement.

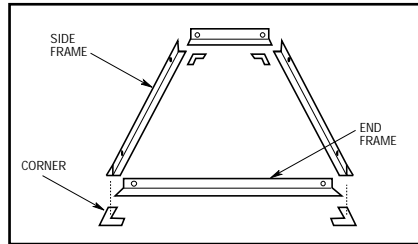

FRAME CONSTRUCTION FOR RECESSED PANELS

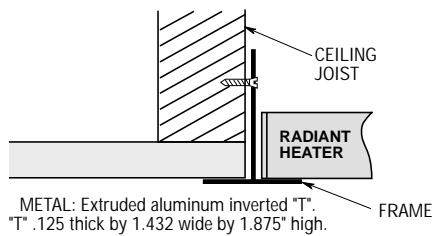

CERTIFICATION AND SAFETY

FIRE RATING - Heating panels do not have a fire rating, but construction is of fire retardant materials. Panels normally are treated like light fixtures. If necessary, acoustical tile can be placed on top of the panels.

HAZARDOUS AREAS - Heating panels do not have a hazardous rating.

CRYSTALLINE SURFACE - The panel's unique crystalline surface greatly enhances the radiant characteristics of the heating panel.

Radiant output is in the 8-10 micron wavelength. This is ideal for comfort. Human skin will absorb 99% of the radiant energy in these wavelengths. Humans themselves radiate heat predominately in that micron range. Without the panel's crystalline surface a panel will be less radiant, operate at higher temperature and produce energy at shorter wavelengths.

ELEMENT - Encapsulated cassette heating element assures uniform temperatures and long life.

ACCESSORIES

PRODUCT	DESCRIPTION
QSF2424	Surface Mounting Frame for 24" x 24" Panels
QSF2448	Surface Mounting Frame for 24" x 48" Panels
QRF2424	Recess Mounting Frame for 24" x 24" Panels
QRF2448	Recess Mounting Frame for 24" x 48" Panels

* Measuring for Custom Ceiling Panels:

- Panels are built to fit inside the dimensions given.
- Measurements must be from "T" Bar Center Line to "T" Bar Center Line
- Do Not Measure Opening

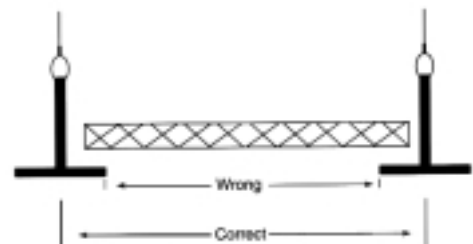

CUSTOM FEATURES

1. CUSTOM SIZE PANELS

While a wide variety of panel sizes are listed as standard, the factory produces thousands of panels each year of varying widths and lengths to order.

SELECTION CHART

CATALOG NUMBER	PANEL WIDTH	WATT DENSITY	WATTS PER PANEL						
			NOMINAL PANEL LENGTH						
			24"-35"	36"-47"	48"-59"	60"-71"	72"-83"	84"-95"	96"
QT+**@@#	10-13	High	155	235	315	390^	N/A	N/A	N/A
		Med.	130	195	260	325^	N/A	N/A	N/A
		Low	105	155	210	260^	N/A	N/A	N/A
	14-17	High	235	350	470	585^	N/A	N/A	N/A
		Med.	195	295	390	490^	N/A	N/A	N/A
		Low	155	235	315	390^	N/A	N/A	N/A
	18-21	High	315	470	625	780	940^	N/A	N/A
		Med.	260	390	520	650	780^	N/A	N/A
		Low	210	315	415	520	625^	N/A	N/A
	22-28	High	375	565	750	940	1125	1315	1500
		Med.	310	470	625	785	940	1095	1250
		Low	250	375	500	625	750	875	1000

LEGEND: + Watt Density: H = High, M = Medium, L = Low
 **Width of Panel
 @Length of Panel
 ^ Maximum Panel Length = 60 inches
 ^^ Maximum Panel Length = 72 Inches.
 # Voltage Designation: 1 = 120, 8 = 208, 2 = 240, 7 = 277, 3 = 347

2. CUSTOM SIZE FRAMES

ACCESSORIES

CATALOG NO.	DESCRIPTION
QSF**@@	Surface Mounting Frame
QRF**@@	Recess Mounting Frame
** Width of Heater (10" to 28")	
@Length of Heater (10" to 96")	

3. TEGULAR (revealed edge)

Tegular systems may utilize a standard grid with a 15/16" cross-T or a "fine line" grid with a 9/16" cross-T. The acoustical tile is notched to hang below the grid creating the revealed edge. Tegular panels are built with a support angle on all four sides to allow the panel front to drop flush with the finished ceiling.

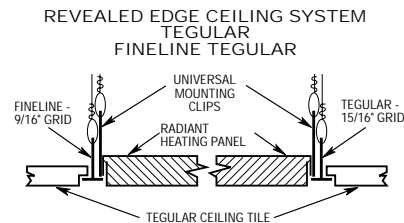

Tegular and Fine line Tegular panels are supplied **standard** with universal mounting clips installed for support chain.

4. CONCEALED SPLINE SYSTEMS

These systems utilize ceiling tiles notched to hide the T-bar grid. Heating panels will be treated in a manner similar to the lights in such a system. We will build a custom recessed frame and panel to fit inside the grid opening. The recessed frame will be suspended independently from the T-bar grid. The result is a flush-mounted panel with an exposed trim finishing off the adjacent tiles and supporting the panel.

5. SILKSCREEN

Radiant heating panels can be silk screened to provide an architectural blend with leading acoustical tiles. For T-bar, concealed spline and tegular ceiling systems.

6. CUSTOM COLORS

Radiant heating panels can be painted any color desired with high temperature acrylic paints without affecting panel performance.

Radiant energy is emitted from heating panels in the 8-10 micron wavelength range. One of the principal characteristics of this wavelength is that it is not color selective as are shorter wavelengths. Consequently, the surface color of the panel is unimportant to heating efficiency and can be considered solely in the light of aesthetics.

7. PANEL FRONTS FOR A CONTINUOUS CEILING LINE

To provide a continuous ceiling line around the perimeter of a building, the factory can provide panel fronts to be interspersed between the functioning heating panels. Field-trimmable filler panels also are available.

8. SEAL TIGHT FLEXIBLE CONDUIT AND CONNECTORS

Radiant ceiling panels come with 1/2" Greenfield flexible conduit and straight connectors as standard equipment. Seal tight connectors and conduit can be substituted at the factory if panels are to be used in high moisture areas or if required by local electrical codes.

9. FACTORY SILICONE SEALED

PANELS FOR USE IN HIGH MOISTURE AREAS - Exterior moisture and condensation do not affect heating panel performance, but water inside the unit can cause the panel to fail. Panels being used in locker rooms and swimming pool areas should be totally sealed with silicone at the factory before shipment. If there is a chance of moisture above the ceiling, then seal tight conduit and seal tight connectors also should be used.

10. LONGER FLEXIBLE CONDUIT

Panels will replace the standard 48" Greenfield with up to 11' of 1/2" flexible conduit.

11. CONTROLS

P/E Switches - factory prewired to heaters. 20 amps - 120V, 240V, 208V and 277V.

Power Relay - factory prewired to heaters. 30 amps single pole, 120 volt holding coil.

12. HEAVIER DUTY PANELS

For special installations the factory can use heavier gauge steel in the construction of the panels.

13. STAINLESS STEEL CONSTRUCTION

PANELS FOR CHLORINE STORAGE AREAS - Special stainless steel panels are available for chlorine storage areas. Panels will be equipped with seal tight connectors and silicone sealed.

14. MODULAR WIRING SYSTEMS

For specific jobs, the factory can substitute modular connectors for the straight connectors and pig tails that are standard equipment.

ARCHITECT'S & ENGINEER'S SPECIFICATIONS *

The electric ceiling heating panel shall be as manufactured by QMark, A Division of Marley Engineered Products, Bennettsville, SC. The construction and design shall permit it to be: recessed ceiling mounted with the use of Recessed Mounting Kit, fit into standard or custom designed modules of a T-bar suspended ceiling, or surface mounted with the use of a Surface Mounting Kit. Panels shall include the custom features listed below.

HEATING ASSEMBLY: The heating assembly shall be UL Listed and CSA Certified and shall consist of powdered graphite encapsulated in a plastic laminate with heavy duty copper buss bars running the entire length, backed by 1 inch, 1 pound density high temperature fiberglass insulation to insulate against heat loss to the ceiling and separated from the inside of the panel by a dielectric insulation to assure uniform heat transfer throughout the entire radiating surface of the heater. The rated input shall be: (62.5 watts/sq. ft. with an average temperature of not more than 165 degree F.) or (95 watts/sq. ft. with an average surface temperature of 200 degree F.), to assure long trouble free life.

The panel voltage shall be _____, (120, 208, 240, 277)

WIRING: For connection to the main power supply, the heater shall be

completely prewired, with the lead wires housed in a 48 inch length of flexible metal conduit and connector for J-Box mounting. Appropriate wiring diagrams shall appear on the back of the panel.

PANEL ASSEMBLY: The metal heating panel, containing the completely prewired heating assembly, shall be of 22 gauge formed galvanized steel front and 24 gauge formed galvanized steel back. Sides are overlapping front and back panels riveted together.

FINISH: The front of the heating panel shall be QMark's unique multi-faceted crystalline type surface finished with high temperature silicone paint.

CUSTOM FEATURES: Radiant heating panels shall be provided with the following custom features:

- ___ **CUSTOM SIZE**
_____ in. Length, _____ in Width.
- ___ **SILK SCREENING** to blend with acoustical tile.
- ___ **REGULAR** (Revealed edge)
- ___ **CUSTOM COLOR** to match architectural samples.
- ___ **PAINTED FRAME** to match heater (Surface or Recess only)
- ___ **FACTORY SILICONE SEALED**
- ___ **SEAL TIGHT FLEXIBLE CONDUIT and CONNECTORS**
- ___ **LONGER FLEXIBLE CONDUIT**

Total length ___ in. by 1/2"
(Max Length 132")

___ **HEAVY DUTY CONSTRUCTION**
___ Gauge front
___ Gauge back

___ **STAINLESS STEEL CONSTRUCTION**
___ Panel
___ Frame

___ **EARTHQUAKE CLIPS**

SURFACE MOUNTING

Surface Mounting Kit shall come in a separate carton which contains: two side frames, two end frames and eight assembly screws.
Frame shall be field assembled before installing on ceiling.

RECESS MOUNTING

Recess Mounting Kit shall come in a separate carton which contains: four frame sections and four corner pieces.

Recess mounting shall require a: (Panel Length + 3/8") X (Panel Width + 3/8") cutout in the ceiling and a secure method of support.

*QMark reserves the right to change specifications without prior notice.

SURFACE MOUNTING

Surface Mounting Kit shall come in a separate carton which contains: two side frames, two end frames and eight assembly screws.

Frame shall be field assembled before installing on ceiling.

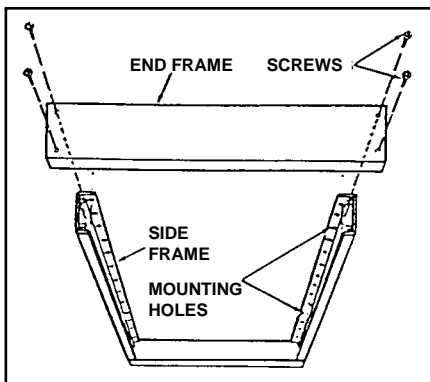

RECESS MOUNTING

Recess Mounting Kit shall come in a separate carton which contains: four frame sections and four corner pieces.

Recess mounting shall require a: (Panel Length + 3/8") X (Panel Width + 3/8") cutout in the ceiling and a secure method of support.

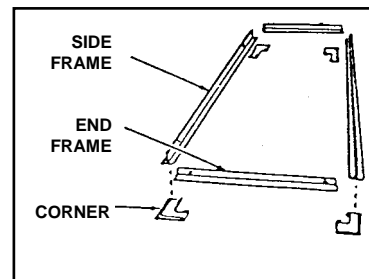



Project: Lakeview Animal Hospital

Submitted Product: Energy Recovery Ventilators

Specification Section: Shown on mechanical plans dated 05/23/2023

Submittal Date: 08/25/2023

Submitted By: Matt Price, mprice@hobbsassociates.com

Mechanical Contractor: TN Mechanical

Unit Tags Included: ERV-01, 02, 03

Product Accessories and Features Include:

- Outdoor installation
- 208/1 voltage
- MERV 8 outdoor and exhaust air filters
- Terminal strip
- Motor starter
- 24 VAC transformer
- Disconnect
- Timed exhaust wheel frost control
- End supply air discharge position
- End return air intake position
- Wheel economizer control – Stop Wheel
- 14” Roof curb for flat roof

ERV-10-20L-VG

Unit Performance

Design Conditions					
Elevation (ft)	Summer		Winter DB (F)	Outdoor Air (CFM)	Exhaust Air (CFM)
	DB (F)	WB (F)			
981	92.0	74.0	13.0	580	580

Unit Specifications			
Qty	Weight (lb)	Unit Installation	Unit ETL Listing
1	298 (+/- 5%)	Outdoor	UL-1812

Configuration			
Outdoor Air		Exhaust Air	
Intake	Discharge	Intake	Discharge
End	End	End	Side

Energy Recovery Performance									
Design Condition	Temperature (F)								Capacity Reduction (BTU/h)
	Outdoor Air		Supply Air		Return Air		Exhaust Air		
	DB	WB	DB	WB	DB	WB/RH	DB	WB	
Summer	92.0	74.0	78.3	65.0	75.0	62.4/50	88.6	71.9	20,097.0
Winter	13.0	10.3	59.7	48.1	72.0	55.6/35	24.4	22.0	29,497.0

Air Performance							
Type	Total Volume (CFM)	External SP (in. wg)	Total SP (in. wg)	FRPM	Fan		
					Qty	Type	Drive-Type
Supply	580	0.66	0.807	1210	1	Forward Curve	Direct
Exhaust	580	0.59	0.673	1225	1	Forward Curve	Direct

Motor Specifications						
Motor	Qty	Operating Power (hp)	Size (hp)	Enclosure	Efficiency	RPM
Supply	1	0.25	1/2	ODP	N/A	1725
Exhaust	1	0.31	1/2	ODP	N/A	1725

Electrical Specifications					
Power Supply	Rating (V/C/P)	MCA (A)	MOP (A)	Fan Power (W/CFM)*	SCCR
Unit	208/60/1	8.9	15.0	0.724	5kA

*Fan Power (W/CFM) = (Supply BHP + Exhaust BHP) / Supply CFM

Construction Features And Accessories

Unit	
UL-1812	Std
Unit Installation - Outdoor	Std
Outdoor Air Filters - 2" MERV 8, 1-16x25	Std
Exhaust Air Filters - 2" MERV 8, 1-16x25	Std
Energy Recovery Device - Polymer Wheel w/ Silica Gel Desiccant	Std
Unit Construction - Single Wall	Std
Insulation - 1 inch 3# R4 fiberglass	Std
Corrosion Resistant Fasteners	Std
Access - Hinged	X
Unit Finish - Galvanized	Std
Two Direct Drive Forward Curved Blowers and VariGreen EC Motors	Std
Single Point Power	Std
Factory Wired Non-Fused Disconnect Switch	Std
Supply Weatherhood: Louvered	Std
Exhaust Weatherhood: Downturn	Std
Controls	
Unit Controls - Terminal Strip	X
Sensors	
Unit On/Off Control - By Others	X
Sensor Monitoring Package	
Heating Enable - None	
Cooling Enable - None	
Supply Fan Control	
Exhaust Fan Control	
Network Protocol	
Energy Wheel Economizer Control - Stop Wheel, Temperature	X
Exhaust Only Operation	
Control Accessories	
Remote Display	
CO2 Sensor	
Dirty Filter Sensor(s)	
Airflow Monitoring - None	
Wheel Rotation Sensor	

Accessories	
Frost Control - Timed Exhaust	X
Service Outlet - 120 VAC GFCI Service Outlet, Shipped Loose	
Spare Filters	
Spare Energy Wheel Segments	
Spare Fan Belts	
Shipped Loose Smoke Detectors	
Outdoor Air Damper	
Return Air Damper	
Roof Curb - GKD - 30.5/42.5-G14	X
Warranty Options	
Unit Warranty - 18 Months (Std.)	Std
Energy Wheel Warranty - 5 Yrs Less Motor	Std

Standard Option	Std
Not Included	
Included	X

Notes
 A backdraft damper is included as an integral part of the exhaust weatherhood assembly.

Supply Fan Charts And Performance

Supply Fan Performance									
Total Volume (CFM)	External SP (in. wg)	Total SP (in. wg)	RPM	Operating Power (hp)	Motor		Fan		
					Qty	Size (hp)	Qty	Type	Drive-Type
580	0.66	0.807	1210	0.25	1	1/2	1	Forward Curve	Direct

Pressure Drop (in. wg)				
Weatherhood	Filter	Damper	External	Total
0.082	0.065	-	0.66	0.807

Sound Performance in Accordance with AMCA										
Sound Power by Octave Band								Lwa	dBA	Sones
62.5	125	250	500	1000	2000	4000	8000			
72.3	82.7	75.5	71	70.5	69.2	67.5	62.7	76.7	65.2	14.1

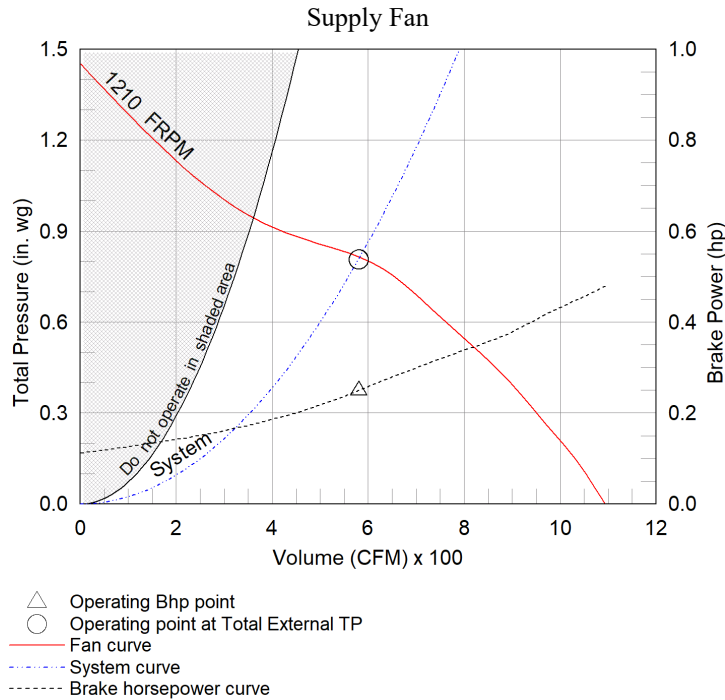

Exhaust Fan Charts And Performance

Exhaust Fan Performance									
Total Volume (CFM)	External SP (in. wg)	Total SP (in. wg)	RPM	Operating Power (hp)	Motor		Fan		
					Qty	Size (hp)	Qty	Type	Drive-Type
580	0.59	0.673	1225	0.31	1	1/2	1	Forward Curve	Direct

Pressure Drop (in. wg)				
Weatherhood	Filter	Damper	External	Total
0.018	0.065	-	0.59	0.673

Sound Performance in Accordance with AMCA										
Sound Power by Octave Band								Lwa	dBA	Sones
62.5	125	250	500	1000	2000	4000	8000			
76.9	78.1	73.5	60.6	62.1	61.1	59.4	53.8	70.1	58.6	9.7

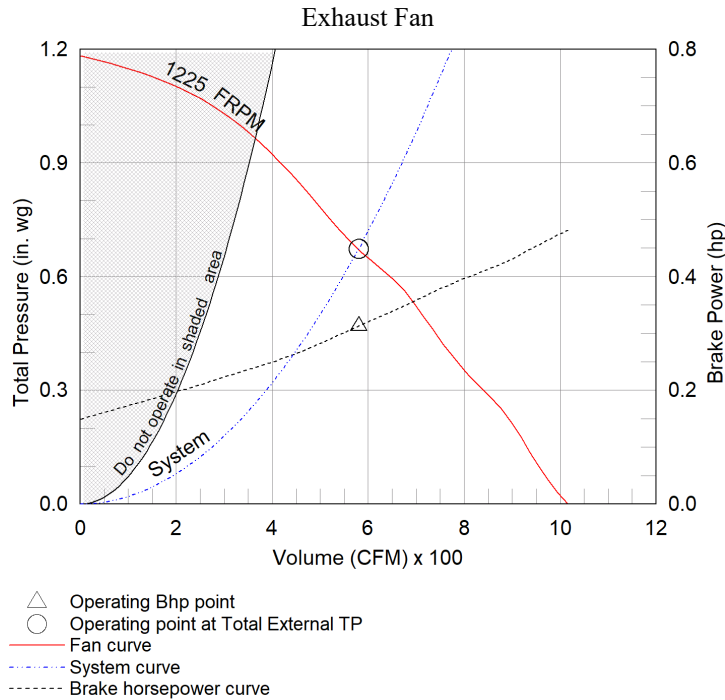

Energy Recovery Summer Performance

Outdoor Air		Supply Air	
Dry Bulb (F)	92.0	Dry Bulb (F)	78.3
Wet Bulb (F)	74.0	Wet Bulb (F)	65.0
Specific Humidity (gr/lb)	103	Specific Humidity (gr/lb)	75
Enthalpy (BTU/lb)	38.2	Enthalpy (BTU/lb)	30.5

Exhaust Air		Return Air	
Dry Bulb (F)	88.6	Dry Bulb (F)	75.0
Wet Bulb (F)	71.9	Rel. Humidity (%)	50
Specific Humidity (gr/lb)	94	Specific Humidity (gr/lb)	67
Enthalpy (BTU/lb)	36.0	Enthalpy (BTU/lb)	28.5

Design Air Flow Conditions			
OA Volume (CFM)	ASHRAE 90.1 OA Enthalpy Recovery Ratio	EA Volume (CFM)	EA Wheel Effectiveness
580	79.6	580	78.5

Outdoor Air Cooling Reduction				
OA Load w/o Energy Recovery		OA Load with Energy Recovery		Equipment Reduction (tons)
(BTU/h)	(tons)	(BTU/h)	(tons)	
25,317.0	2.11	5,220.0	0.44	1.67

Summer Conditions

- 1 = Outdoor Air Design
- 2 = Energy Wheel
- 3 = Exhaust Air Entering Wheel

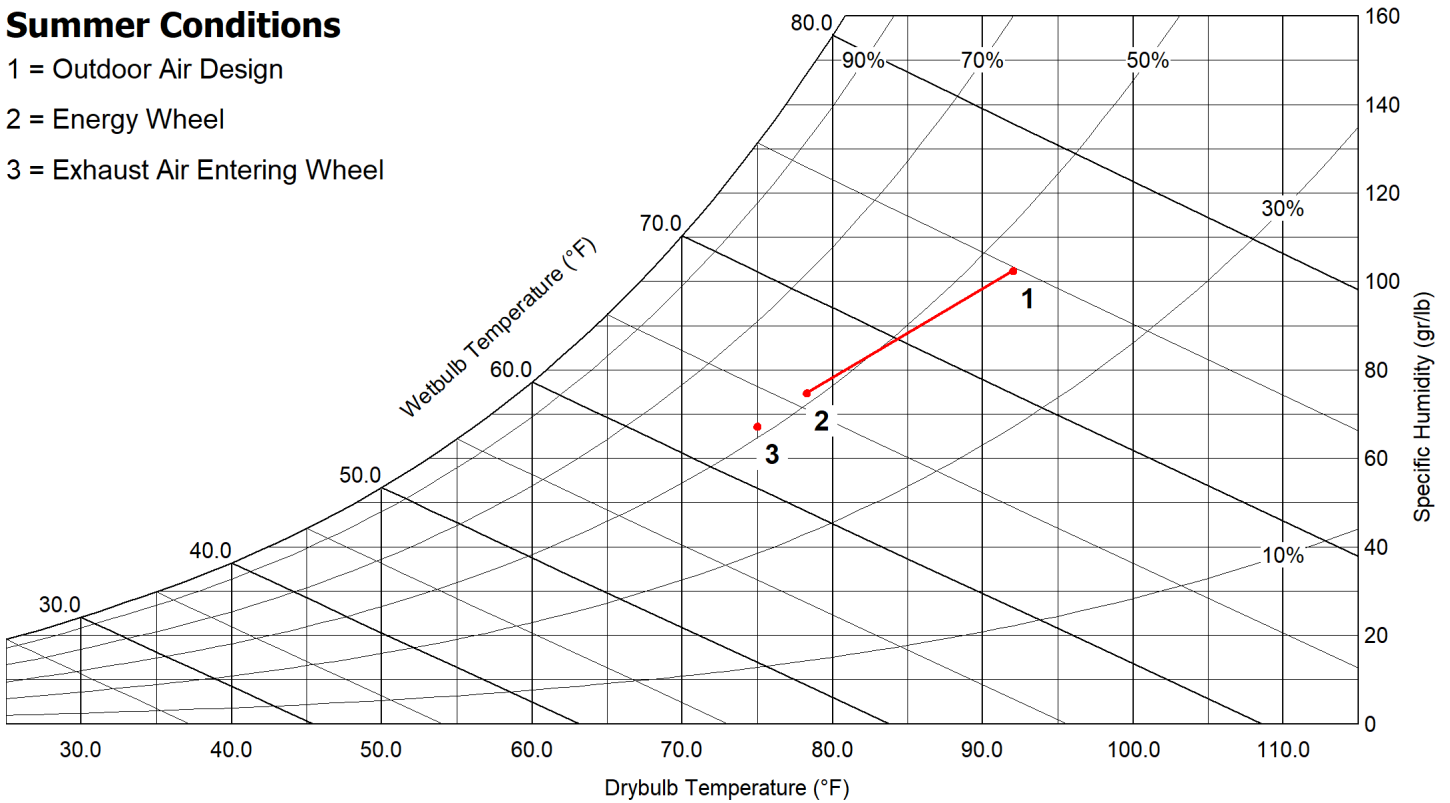

Energy Recovery Winter Performance

Outdoor Air		Supply Air	
Dry Bulb (F)	13.0	Dry Bulb (F)	59.7
Wet Bulb (F)	10.3	Wet Bulb (F)	48.1
Specific Humidity (gr/lb)	6	Specific Humidity (gr/lb)	33
Enthalpy (BTU/lb)	4.0	Enthalpy (BTU/lb)	19.5
Exhaust Air		Return Air	
Dry Bulb (F)	24.4	Dry Bulb (F)	72.0
Wet Bulb (F)	22.0	Rel. Humidity (%)	35
Specific Humidity (gr/lb)	14	Specific Humidity (gr/lb)	42
Enthalpy (BTU/lb)	7.9	Enthalpy (BTU/lb)	23.9

Design Air Flow Conditions			
OA Volume (CFM)	ASHRAE 90.1 OA Enthalpy Recovery Ratio	EA Volume (CFM)	EA Wheel Effectiveness
580	78	580	79.4

Outdoor Air Heating Reduction			
OA Load w/o Energy Recovery (BTU/h)	OA Load with Energy Recovery (BTU/h)	Equipment Reduction (BTU/h)	Sensible Effectiveness (%)
37,266.0	7,769.0	29,497.0	81.1

Winter Conditions

- 1 = Outdoor Air Design
- 2 = Energy Wheel
- 3 = Exhaust Air Entering Wheel

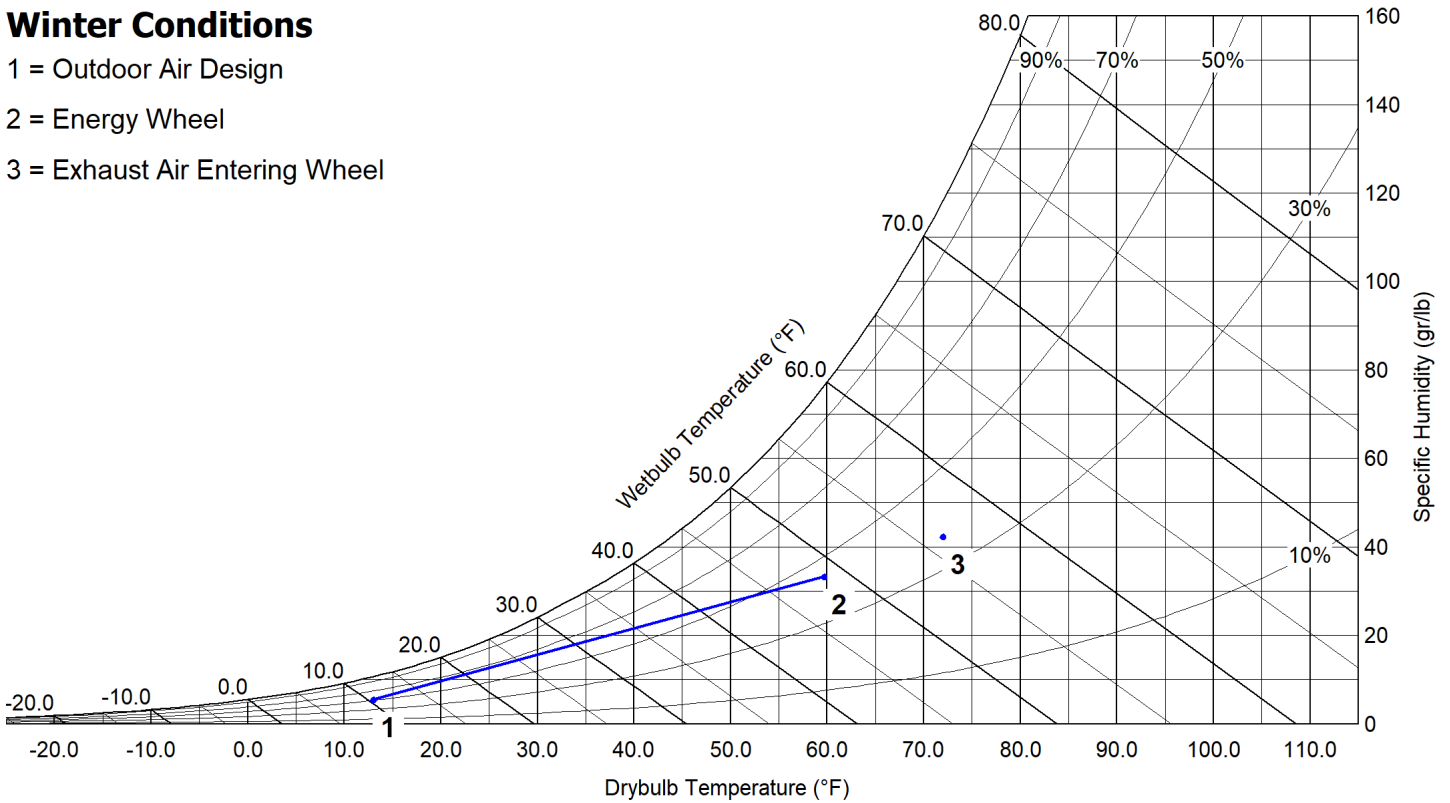

AHRI Performance Ratings

Energy Recovery Performance Rating in accordance with AHRI Standard 1060 (I-P)							
Rated Airflow (SCFM)		Net Supply Airflow (SCFM)	EATR (%)	OACF	Pressure Drop (in. wg)		Purge Angle (degrees)
Leaving Supply	Entering Exhaust				Supply	Exhaust	
596	596	580	2.8	1.17	0.63	0.63	0

Thermal Effectiveness Ratings							
Enthalpy Recovery Ratio (%)		Sensible Effectiveness (%)		Latent Effectiveness (%)		Total Effectiveness (%)	
Summer	Winter	Summer	Winter	Summer	Winter	Summer	Winter
79.6	78	80.9	81.1	77.7	77.9	78.5	79.4

Note(s)

Summer Design Conditions:
Certified in accordance with the AHRI ERV Certification Program, which is based on AHRI Standard 1060. Certified units may be found in the AHRI Directory at www.ahridirectory.org.



Winter Design Conditions:
Application Rating is outside the scope of AHRI ERV Certification Program, but is rated in accordance with AHRI Standard 1060.

Energy Saving Analysis

Design Conditions									
Volume (CFM)		OA Enthalpy Recovery Ratio (%)		Outdoor (DB/WB)		Indoor (DB)		Relative Humidity (%)	
Supply	Exhaust	Summer	Winter	Summer	Winter	Summer	Winter	Summer	Winter
580	580	79.6	78	92.0 / 74.0	13.0 / 10.3	75.0	72.0	50.0	35.0

Cooling Analysis		
Cooling Range (F)	Total Hours Annually	Enthalpy (BTU/lb)
112.5	0	0.0
107.5	0	0.0
102.5	3	34.6
97.5	9	37.5
92.5	64	39.0
87.5	176	37.4
82.5	410	35.0
77.5	354	32.8
72.5	260	30.2

Heating Analysis	
Heating Range (F)	Total Hours Annually
62.5	252
57.5	273
52.5	214
47.5	209
42.5	170
37.5	171
32.5	129
27.5	74
22.5	52
17.5	17
12.5	4
7.5	0
2.5	0
-2.5	0
-7.5	0
-12.5	0
-17.5	0

Energy Savings				
	Load w/o Energy Recovery (BTU)	Load with Energy Recovery (BTU)	Annual Savings (BTU)	Annual Savings (USD)
Cooling	18,190,655	3,710,893	14,479,762	154
Heating	24,460,117	4,989,863	19,470,254	222
Energy Savings Cost				\$376

Notes				
Location	Operating Time	Electric Cost (USD)	Heat Source	Heating Cost (USD)
Knoxville Mcghee Tyson Airport, TN (United States)	12 hours/day, 5 days/week	0.08	Gas	0.8

Isometric Drawings

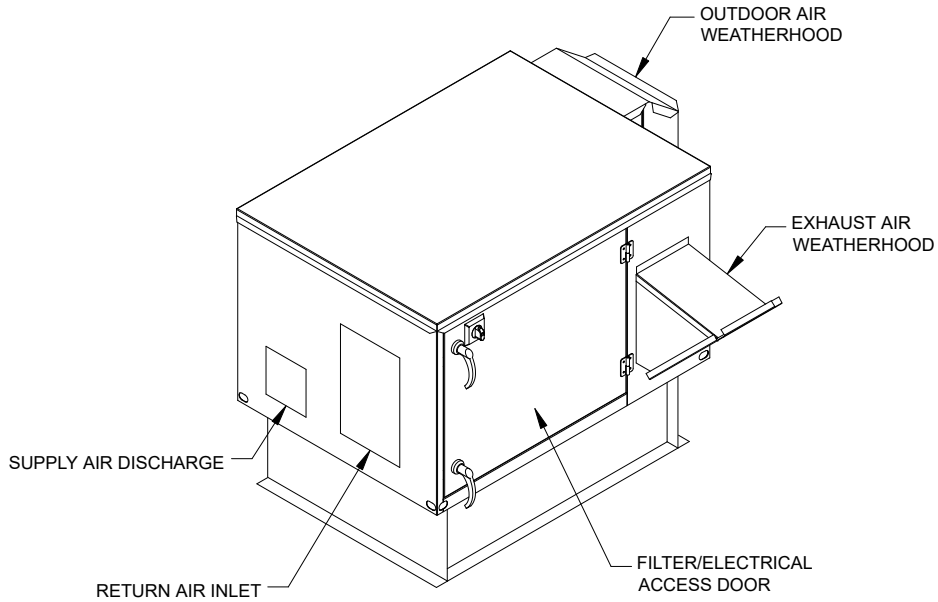

Back Right Isometric

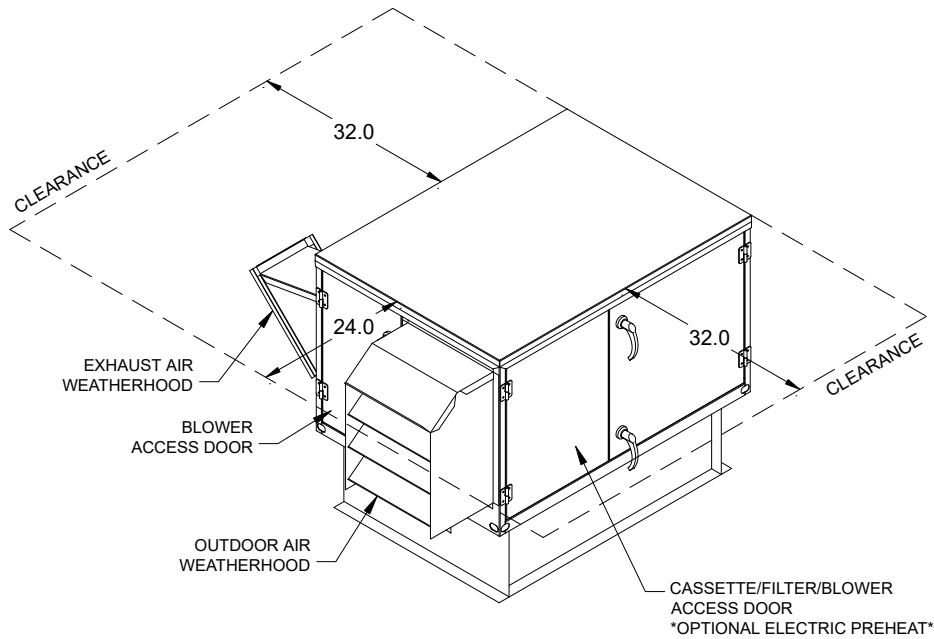

Front Left Isometric

Overview Drawings

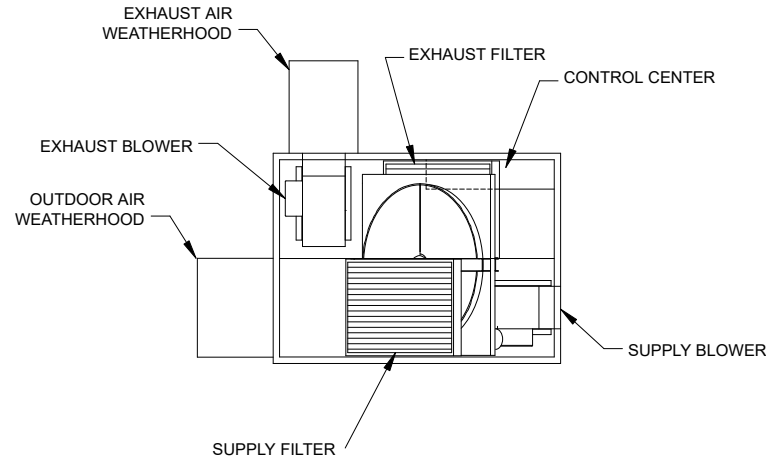

Plan

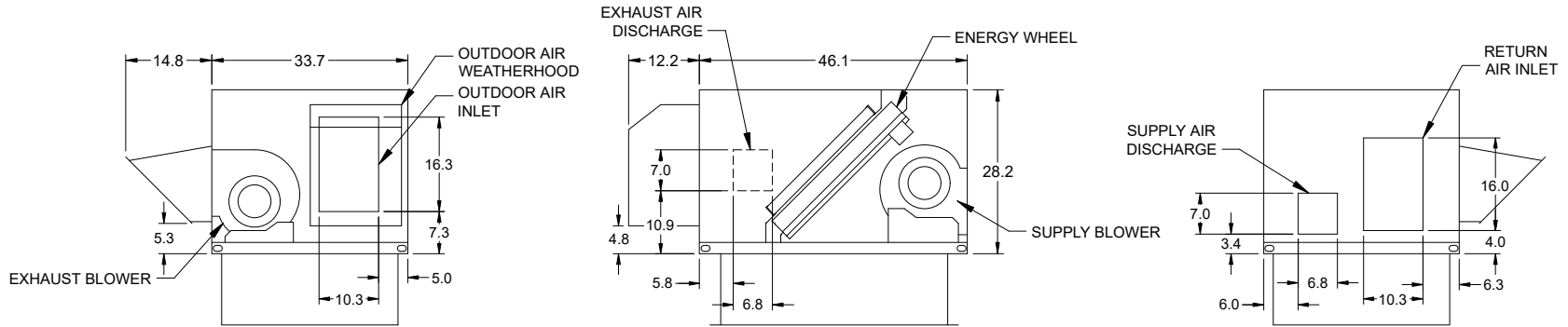

Left End

Elevation

Right End

Corner Weights

83 lb

64 lb

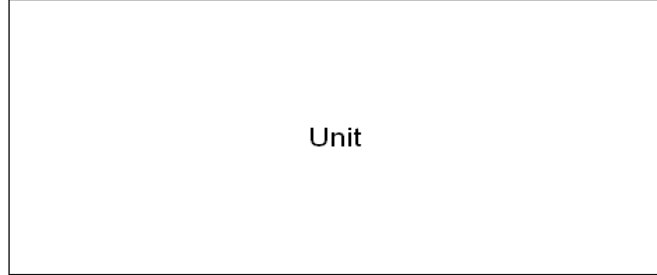

85 lb

66 lb

Note

Estimated corner weights are shown looking down on unit and the outside air intake will be on the left. Weights are applied at the base of the unit. Images not drawn to scale.

Terminal Strip Controls

BASIC UNIT CONTROLS:

The Energy Recovery Unit will be provided from the factory with an integral control center including: a single non-fused disconnect, 24 VAC transformer, terminal strip, fan contactors and overloads and energy wheel VFD.

ON/OFF CONTROL:

Within the unit control center, a digital signal must be field wired into the terminal strip (connecting terminals R and G) to control unit startup or shutdown.

This on/off signal is coming from:

By Others: The unit shall be energized by a field supplied and wired digital contact.

Startup (Digital Contact Closes)

- Exhaust fan ON.
- Supply fan ON.
- Energy Wheel is energized.

Shutdown (Digital Contact Opens)

- Supply fan, exhaust fan and energy wheel de-energized.

FROST CONTROL

Frost Control for the energy wheel is enabled when frost is present on the wheel; based on the outside air temperature and the pressure drop across the wheel. If the outdoor air temperature is below 5 F and the differential pressure across the wheel is above 1.5" frost control will enable.

Timed Exhaust:

When frosting has occurred, the supply blower is cycled (30 min. ON/ 5 min. OFF) to allow the warm exhaust air to defrost the wheel. Once either the pressure drop decreases below the pressure switch set point, or the outdoor air temperature increases above the temperature set point, the unit will resume normal operation.

ECONOMIZER SEQUENCE

Stop Wheel - Temperature:

When the application requires cooling (Digital call for cooling from the building or space, R->Y1), and the outdoor air conditions are suitable for free cooling the energy wheel will be de-energized. When the space cooling is satisfied, or the outdoor air temperature is not suitable for free cooling, the wheel will resume normal operation. The economizer will be locked out when the outdoor air is < 50 F (adj.) or > 65 F (adj.)

Wiring Diagram

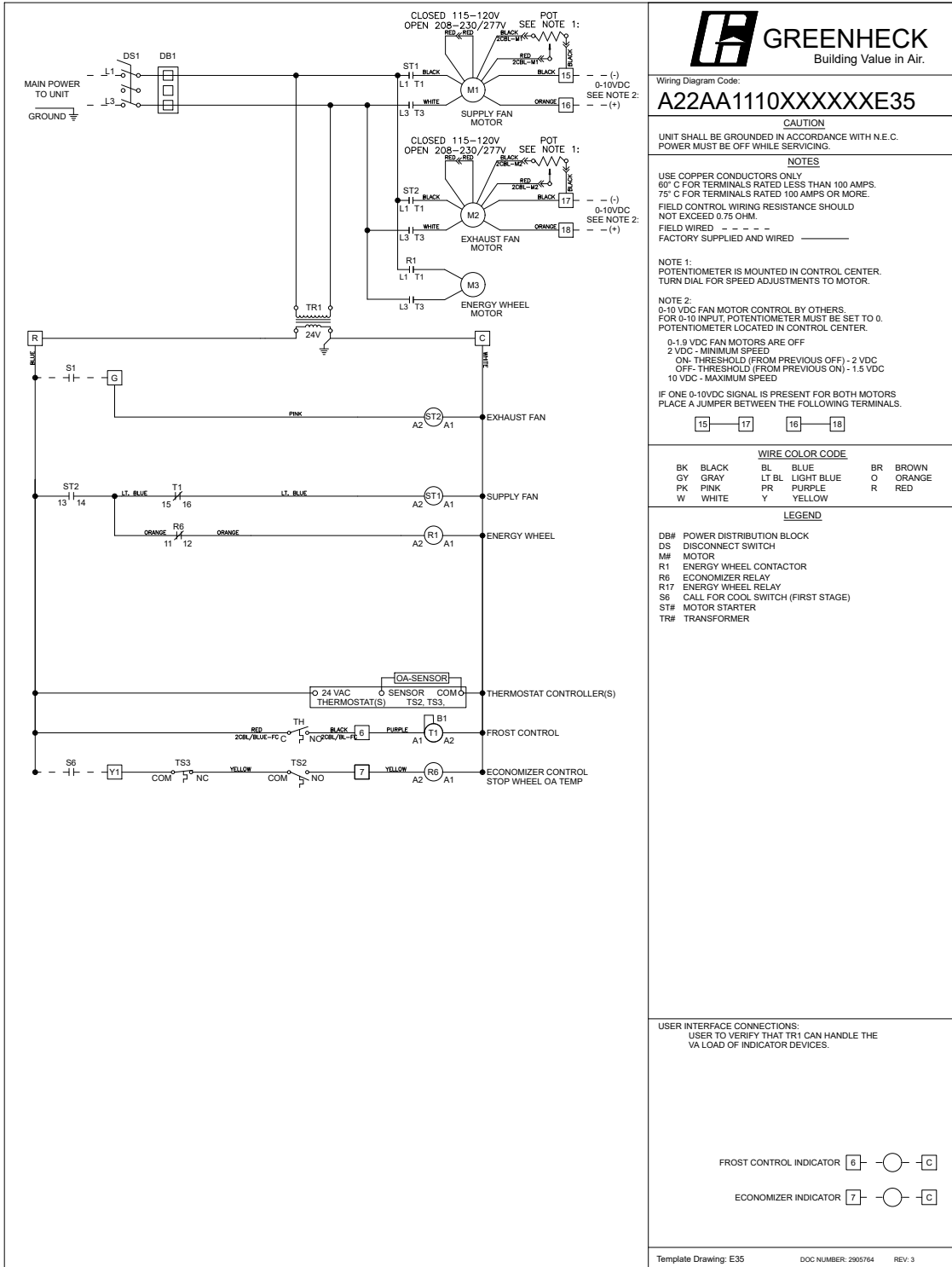

Wiring Diagram Code:
A22AA110XXXXXXE35

CAUTION
UNIT SHALL BE GROUNDED IN ACCORDANCE WITH N.E.C.
POWER MUST BE OFF WHILE SERVICING.

NOTES
USE COPPER CONDUCTORS ONLY
60° C FOR TERMINALS RATED LESS THAN 100 AMPS.
75° C FOR TERMINALS RATED 100 AMPS OR MORE.
FIELD CONTROL WIRING RESISTANCE SHOULD NOT EXCEED 0.75 OHM.
FIELD WIRED — — — — —
FACTORY SUPPLIED AND WIRED — — — — —

NOTE 1:
POTENTIOMETER IS MOUNTED IN CONTROL CENTER.
TURN DIAL FOR SPEED ADJUSTMENTS TO MOTOR.

NOTE 2:
0-10 VDC FAN MOTOR CONTROL BY OTHERS.
FOR 0-10 INPUT, POTENTIOMETER MUST BE SET TO 0.
POTENTIOMETER LOCATED IN CONTROL CENTER.

0-1.9 VDC FAN MOTORS ARE OFF
2 VDC - MINIMUM SPEED
ON- THRESHOLD (FROM PREVIOUS OFF) - 2 VDC
OFF- THRESHOLD (FROM PREVIOUS ON) - 1.5 VDC
10 VDC - MAXIMUM SPEED

IF ONE 0-10VDC SIGNAL IS PRESENT FOR BOTH MOTORS
PLACE A JUMPER BETWEEN THE FOLLOWING TERMINALS.



WIRE COLOR CODE

BK	BLACK	BL	BLUE	BR	BROWN
GY	GRAY	LT BL	LIGHT BLUE	O	ORANGE
PK	PINK	PR	PURPLE	R	RED
W	WHITE	Y	YELLOW		

LEGEND

- DB# POWER DISTRIBUTION BLOCK
- DS DISCONNECT SWITCH
- M# MOTOR
- R1 ENERGY WHEEL CONTACTOR
- R6 ECONOMIZER RELAY
- R17 ENERGY WHEEL RELAY
- S6 CALL FOR COOL SWITCH (FIRST STAGE)
- ST# MOTOR STARTER
- TR# TRANSFORMER

USER INTERFACE CONNECTIONS:
USER TO VERIFY THAT TRY CAN HANDLE THE
V LOAD OF INDICATOR DEVICES.

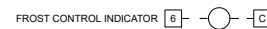

Warranty Statement for ERV Preconditioners

Unit Warranty

Greenheck warrants the equipment to be free from defects in material and workmanship for a period of 18 months from the date of shipment. Initial startup must be completed within six months of the shipment date, and a startup report must be submitted to Greenheck.

Energy Wheel Warranty

The energy recovery wheel is warranted to be free from defects in material and workmanship for a period of 5 years from the shipment date. This warranty applies to all parts and components in the energy recovery cassettes with the exception of the motor.

Warranty Notes

Any component which proves defective during the warranty period will be repaired or replaced at Greenheck's sole option when returned to our factory, transportation prepaid. All warranties do not include labor costs associated with troubleshooting, removal, or installation. Greenheck will not be liable for any consequential, punitive, or incidental damages resulting from use, repair, or operation of any Greenheck product. These warranties are exclusive and are in lieu of all other warranties, whether written, oral, or implied, including the warranty of merchantability and the warranty of fitness for a particular purpose. No person (including any agent or salesperson) has authority to expand Seller's obligation beyond the terms of this warranty, or to state that the performance of the product is other than that published by Seller.

As a result of our commitment to continuous improvement, Greenheck reserves the right to change specifications without notice.

GKD Roof Curb

Model: GKD-30.5/42.5-G14

Curb Height (in.)	Curb Length (in.)	Curb Width (in.)	Material	Finish Type	Duct Adapter	Curb Weight (lb)
14	42.5	30.5	Galvanized	Galvanized	Yes	50

Standard Construction Features:
All dimensions shown in inches.
Weight shown is within +/-5%.
If unit is selected with side or end discharge/return, there will not be bottom connections supplied with the curb.
18 gauge galvanized steel (perimeter channels).
18 gauge galvanized steel (interior channels).
Ships knocked down for field assembly.
Curb insulation to be provided by others.

**Top View
of Curb**

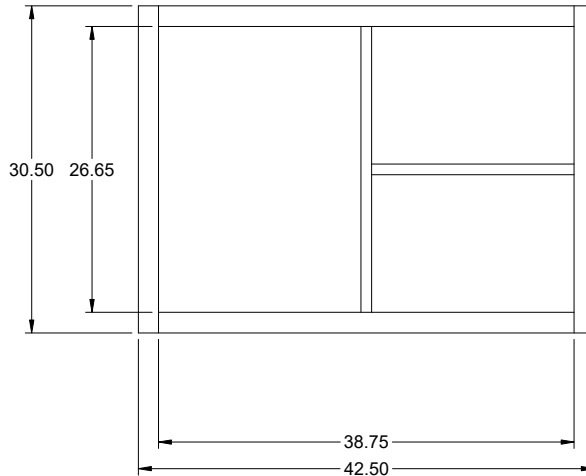

**Cross-Section
View of Unit
on Curb**

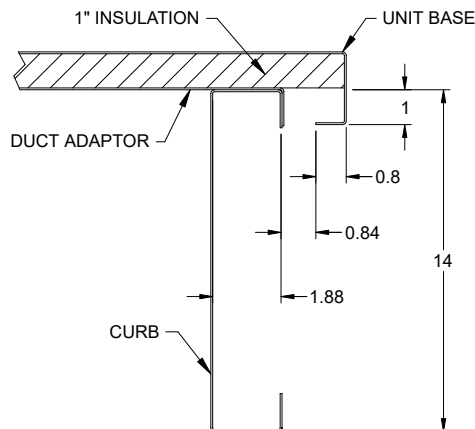

ERV-10-20L-VG

Unit Performance

Design Conditions					
Elevation (ft)	Summer		Winter DB (F)	Outdoor Air (CFM)	Exhaust Air (CFM)
	DB (F)	WB (F)			
981	92.0	74.0	13.0	680	680

Unit Specifications			
Qty	Weight (lb)	Unit Installation	Unit ETL Listing
1	298 (+/- 5%)	Outdoor	UL-1812

Configuration			
Outdoor Air		Exhaust Air	
Intake	Discharge	Intake	Discharge
End	End	End	Side

Energy Recovery Performance									
Design Condition	Temperature (F)								Capacity Reduction (BTU/h)
	Outdoor Air		Supply Air		Return Air		Exhaust Air		
	DB	WB	DB	WB	DB	WB/RH	DB	WB	
Summer	92.0	74.0	78.6	65.3	75.0	62.4/50	88.3	71.6	22,950.0
Winter	13.0	10.3	58.5	47.4	72.0	55.6/35	25.5	23.1	33,694.0

Air Performance							
Type	Total Volume (CFM)	External SP (in. wg)	Total SP (in. wg)	FRPM	Fan		
					Qty	Type	Drive-Type
Supply	680	0.71	0.912	1312	1	Forward Curve	Direct
Exhaust	680	0.62	0.733	1333	1	Forward Curve	Direct

Motor Specifications						
Motor	Qty	Operating Power (hp)	Size (hp)	Enclosure	Efficiency	RPM
Supply	1	0.34	1/2	ODP	N/A	1725
Exhaust	1	0.43	1/2	ODP	N/A	1725

Electrical Specifications					
Power Supply	Rating (V/C/P)	MCA (A)	MOP (A)	Fan Power (W/CFM)*	SCCR
Unit	208/60/1	8.9	15.0	0.843	5kA

*Fan Power (W/CFM) = (Supply BHP + Exhaust BHP) / Supply CFM

Construction Features And Accessories

Unit	
UL-1812	Std
Unit Installation - Outdoor	Std
Outdoor Air Filters - 2" MERV 8, 1-16x25	Std
Exhaust Air Filters - 2" MERV 8, 1-16x25	Std
Energy Recovery Device - Polymer Wheel w/ Silica Gel Desiccant	Std
Unit Construction - Single Wall	Std
Insulation - 1 inch 3# R4 fiberglass	Std
Corrosion Resistant Fasteners	Std
Access - Hinged	X
Unit Finish - Galvanized	Std
Two Direct Drive Forward Curved Blowers and VariGreen EC Motors	Std
Single Point Power	Std
Factory Wired Non-Fused Disconnect Switch	Std
Supply Weatherhood: Louvered	Std
Exhaust Weatherhood: Downturn	Std
Controls	
Unit Controls - Terminal Strip	X
Sensors	
Unit On/Off Control - By Others	X
Sensor Monitoring Package	
Heating Enable - None	
Cooling Enable - None	
Supply Fan Control	
Exhaust Fan Control	
Network Protocol	
Energy Wheel Economizer Control - Stop Wheel, Temperature	X
Exhaust Only Operation	
Control Accessories	
Remote Display	
CO2 Sensor	
Dirty Filter Sensor(s)	
Airflow Monitoring - None	
Wheel Rotation Sensor	

Accessories	
Frost Control - Timed Exhaust	X
Service Outlet - 120 VAC GFCI Service Outlet, Shipped Loose	
Spare Filters	
Spare Energy Wheel Segments	
Spare Fan Belts	
Shipped Loose Smoke Detectors	
Outdoor Air Damper	
Return Air Damper	
Roof Curb - GKD - 30.5/42.5-G14	X
Warranty Options	
Unit Warranty - 18 Months (Std.)	Std
Energy Wheel Warranty - 5 Yrs Less Motor	Std

Standard Option	Std
Not Included	
Included	X

Notes
 A backdraft damper is included as an integral part of the exhaust weatherhood assembly.

Supply Fan Charts And Performance

Supply Fan Performance									
Total Volume (CFM)	External SP (in. wg)	Total SP (in. wg)	RPM	Operating Power (hp)	Motor		Fan		
					Qty	Size (hp)	Qty	Type	Drive-Type
680	0.71	0.912	1312	0.34	1	1/2	1	Forward Curve	Direct

Pressure Drop (in. wg)				
Weatherhood	Filter	Damper	External	Total
0.113	0.089	-	0.71	0.912

Sound Performance in Accordance with AMCA										
Sound Power by Octave Band								Lwa	dBA	Sones
62.5	125	250	500	1000	2000	4000	8000			
71.6	80.9	77.4	71.6	71.4	69.6	68	63.3	77.3	65.8	14.4

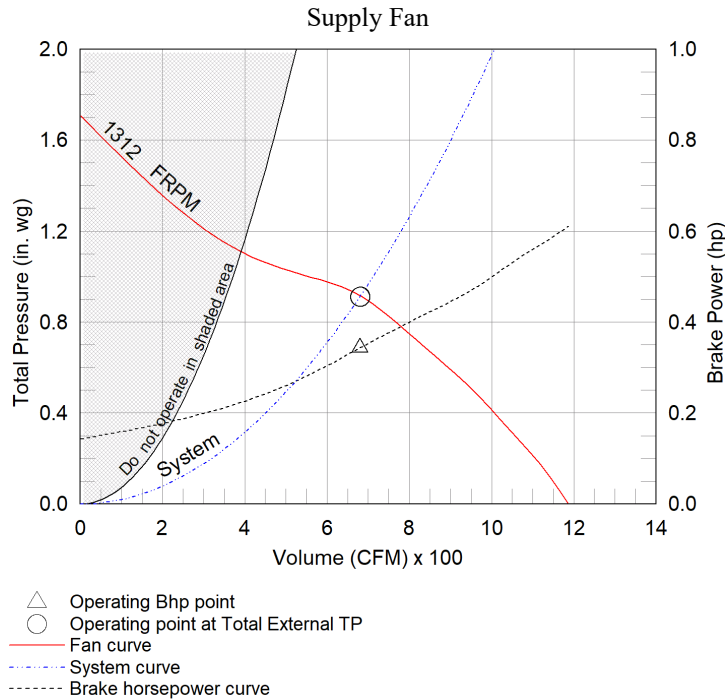

Exhaust Fan Charts And Performance

Exhaust Fan Performance									
Total Volume (CFM)	External SP (in. wg)	Total SP (in. wg)	RPM	Operating Power (hp)	Motor		Fan		
					Qty	Size (hp)	Qty	Type	Drive-Type
680	0.62	0.733	1333	0.43	1	1/2	1	Forward Curve	Direct

Pressure Drop (in. wg)				
Weatherhood	Filter	Damper	External	Total
0.025	0.089	-	0.62	0.733

Sound Performance in Accordance with AMCA										
Sound Power by Octave Band								Lwa	dBA	Sones
62.5	125	250	500	1000	2000	4000	8000			
76.9	78.5	74.5	60.9	62	61.2	59.5	53.9	70.5	59	10.1

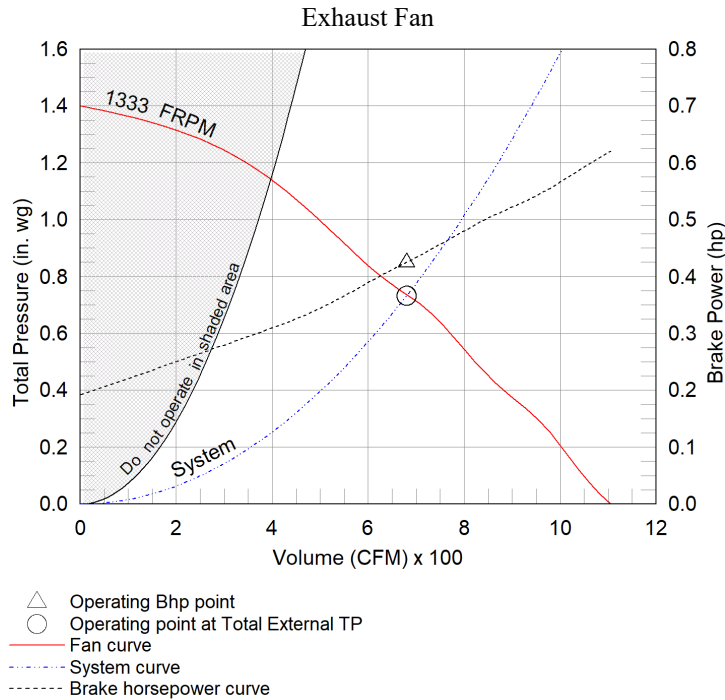

Energy Recovery Summer Performance

Outdoor Air		Supply Air	
Dry Bulb (F)	92.0	Dry Bulb (F)	78.6
Wet Bulb (F)	74.0	Wet Bulb (F)	65.3
Specific Humidity (gr/lb)	103	Specific Humidity (gr/lb)	75
Enthalpy (BTU/lb)	38.2	Enthalpy (BTU/lb)	30.7
Exhaust Air		Return Air	
Dry Bulb (F)	88.3	Dry Bulb (F)	75.0
Wet Bulb (F)	71.6	Rel. Humidity (%)	50
Specific Humidity (gr/lb)	93	Specific Humidity (gr/lb)	67
Enthalpy (BTU/lb)	35.8	Enthalpy (BTU/lb)	28.5

Design Air Flow Conditions			
OA Volume (CFM)	ASHRAE 90.1 OA Enthalpy Recovery Ratio	EA Volume (CFM)	EA Wheel Effectiveness
680	77.7	680	76.5

Outdoor Air Cooling Reduction				
OA Load w/o Energy Recovery		OA Load with Energy Recovery		Equipment Reduction (tons)
(BTU/h)	(tons)	(BTU/h)	(tons)	
29,682.0	2.47	6,732.0	0.56	1.91

Summer Conditions

- 1 = Outdoor Air Design
- 2 = Energy Wheel
- 3 = Exhaust Air Entering Wheel

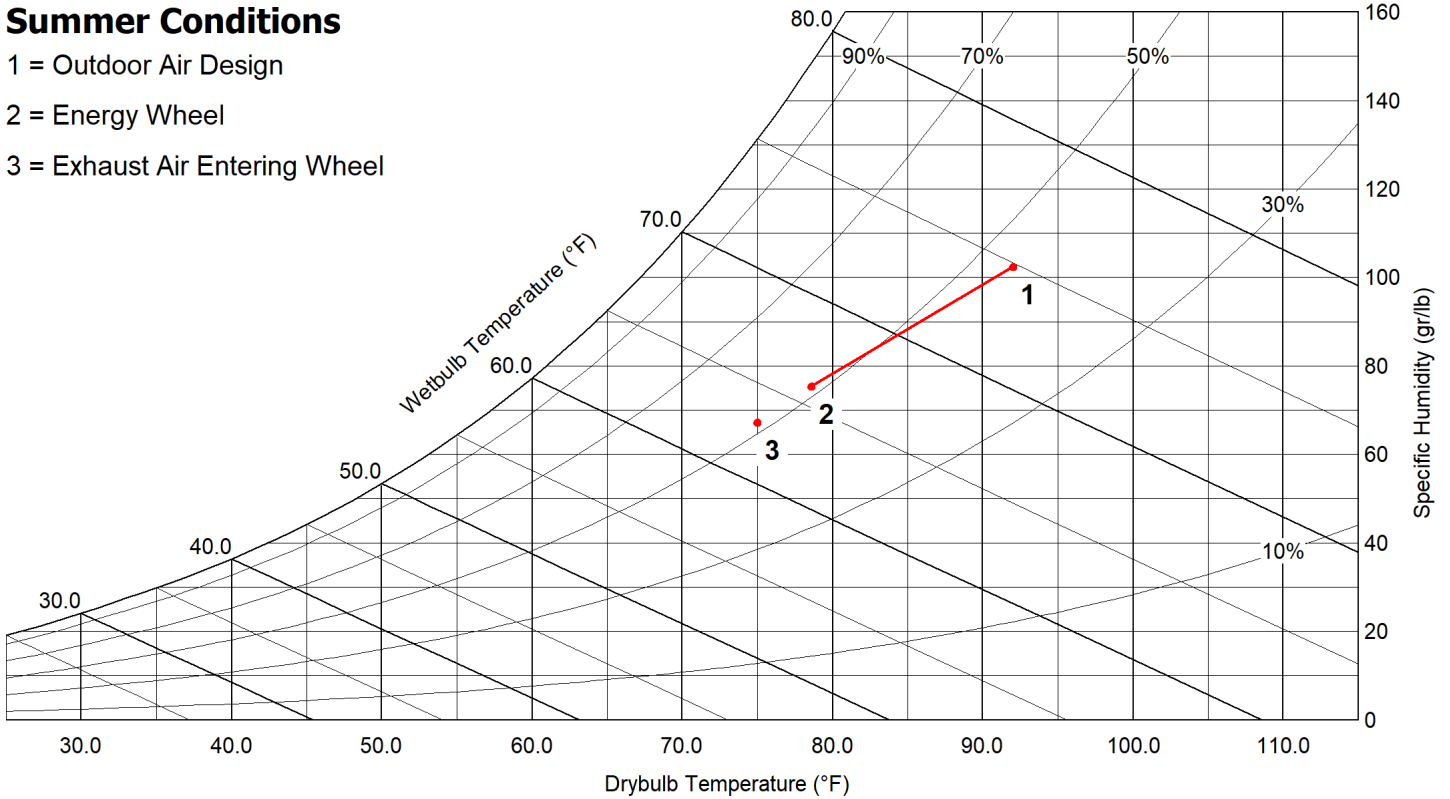

Energy Recovery Winter Performance

Outdoor Air		Supply Air	
Dry Bulb (F)	13.0	Dry Bulb (F)	58.5
Wet Bulb (F)	10.3	Wet Bulb (F)	47.4
Specific Humidity (gr/lb)	6	Specific Humidity (gr/lb)	33
Enthalpy (BTU/lb)	4.0	Enthalpy (BTU/lb)	19.1
Exhaust Air		Return Air	
Dry Bulb (F)	25.5	Dry Bulb (F)	72.0
Wet Bulb (F)	23.1	Rel. Humidity (%)	35
Specific Humidity (gr/lb)	15	Specific Humidity (gr/lb)	42
Enthalpy (BTU/lb)	8.3	Enthalpy (BTU/lb)	23.9

Design Air Flow Conditions			
OA Volume (CFM)	ASHRAE 90.1 OA Enthalpy Recovery Ratio	EA Volume (CFM)	EA Wheel Effectiveness
680	76.1	680	77.4

Outdoor Air Heating Reduction			
OA Load w/o Energy Recovery (BTU/h)	OA Load with Energy Recovery (BTU/h)	Equipment Reduction (BTU/h)	Sensible Effectiveness (%)
43,691.0	9,997.0	33,694.0	79.3

Winter Conditions

- 1 = Outdoor Air Design
- 2 = Energy Wheel
- 3 = Exhaust Air Entering Wheel

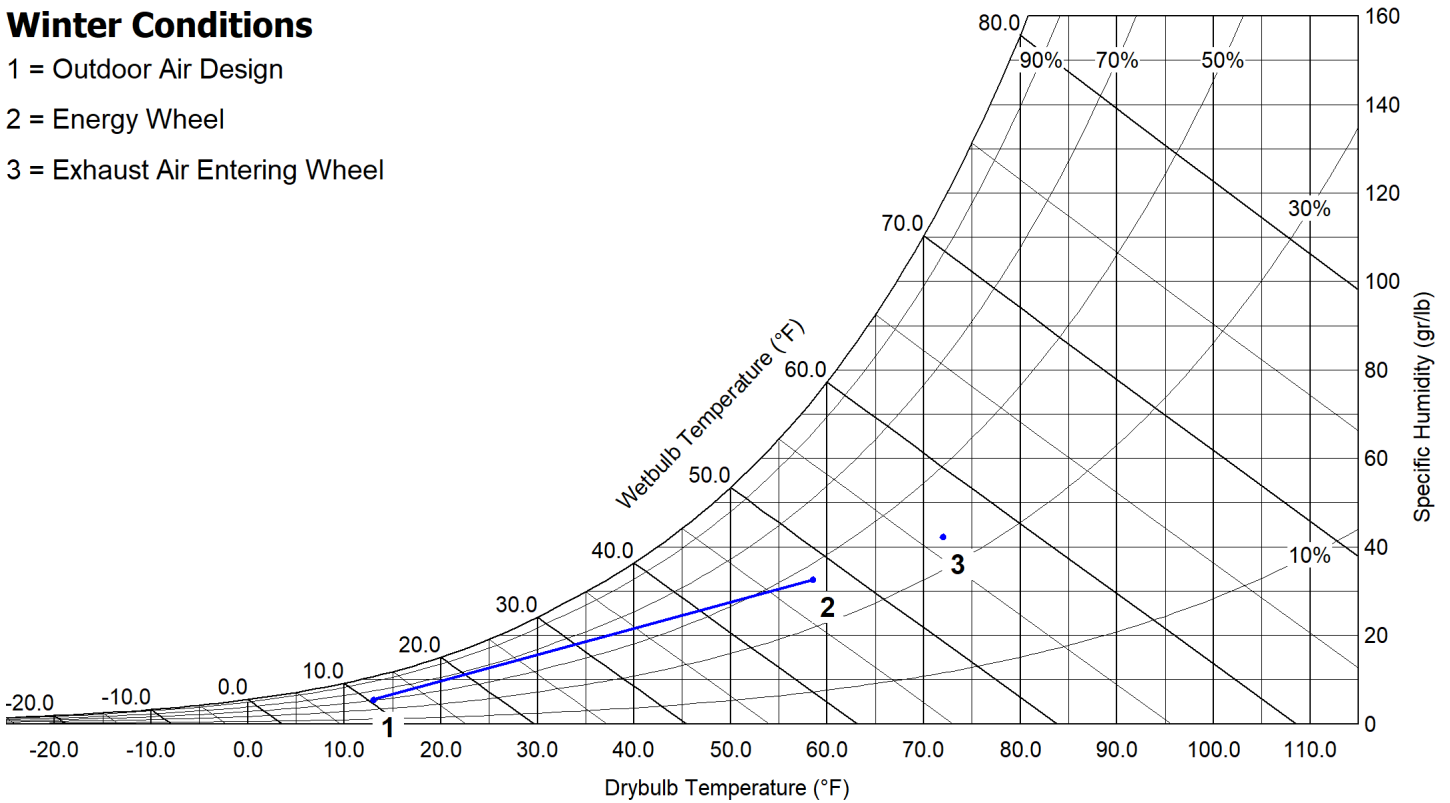

AHRI Performance Ratings

Energy Recovery Performance Rating in accordance with AHRI Standard 1060 (I-P)							
Rated Airflow (SCFM)		Net Supply Airflow (SCFM)	EATR (%)	OACF	Pressure Drop (in. wg)		Purge Angle (degrees)
Leaving Supply	Entering Exhaust				Supply	Exhaust	
703	703	680	3.3	1.14	0.74	0.74	0

Thermal Effectiveness Ratings							
Enthalpy Recovery Ratio (%)		Sensible Effectiveness (%)		Latent Effectiveness (%)		Total Effectiveness (%)	
Summer	Winter	Summer	Winter	Summer	Winter	Summer	Winter
77.7	76.1	79	79.3	75.8	76	76.5	77.4

Note(s)

Summer Design Conditions:
Certified in accordance with the AHRI ERV Certification Program, which is based on AHRI Standard 1060. Certified units may be found in the AHRI Directory at www.ahridirectory.org.



Winter Design Conditions:
Application Rating is outside the scope of AHRI ERV Certification Program, but is rated in accordance with AHRI Standard 1060.

Energy Saving Analysis

Design Conditions									
Volume (CFM)		OA Enthalpy Recovery Ratio (%)		Outdoor (DB/WB)		Indoor (DB)		Relative Humidity (%)	
Supply	Exhaust	Summer	Winter	Summer	Winter	Summer	Winter	Summer	Winter
680	680	77.7	76.1	92.0 / 74.0	13.0 / 10.3	75.0	72.0	50.0	35.0

Cooling Analysis		
Cooling Range (F)	Total Hours Annually	Enthalpy (BTU/lb)
112.5	0	0.0
107.5	0	0.0
102.5	3	34.6
97.5	9	37.5
92.5	64	39.0
87.5	176	37.4
82.5	410	35.0
77.5	354	32.8
72.5	260	30.2

Heating Analysis	
Heating Range (F)	Total Hours Annually
62.5	252
57.5	273
52.5	214
47.5	209
42.5	170
37.5	171
32.5	129
27.5	74
22.5	52
17.5	17
12.5	4
7.5	0
2.5	0
-2.5	0
-7.5	0
-12.5	0
-17.5	0

Energy Savings				
	Load w/o Energy Recovery (BTU)	Load with Energy Recovery (BTU)	Annual Savings (BTU)	Annual Savings (USD)
Cooling	21,326,975	4,755,916	16,571,059	176
Heating	28,677,376	6,395,056	22,282,320	255
Energy Savings Cost				\$431

Notes				
Location	Operating Time	Electric Cost (USD)	Heat Source	Heating Cost (USD)
Knoxville Mcghee Tyson Airport, TN (United States)	12 hours/day, 5 days/week	0.08	Gas	0.8

Isometric Drawings

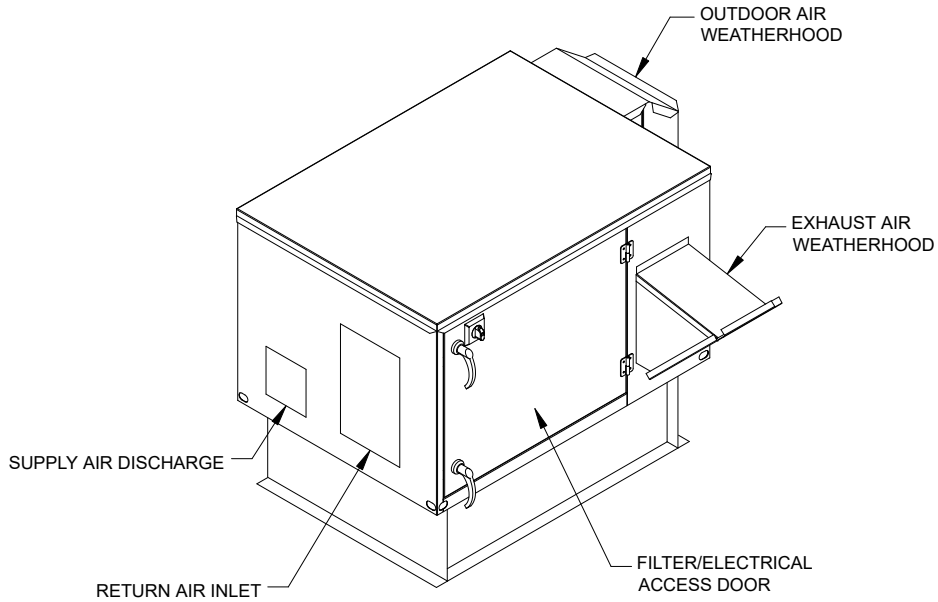

Back Right Isometric

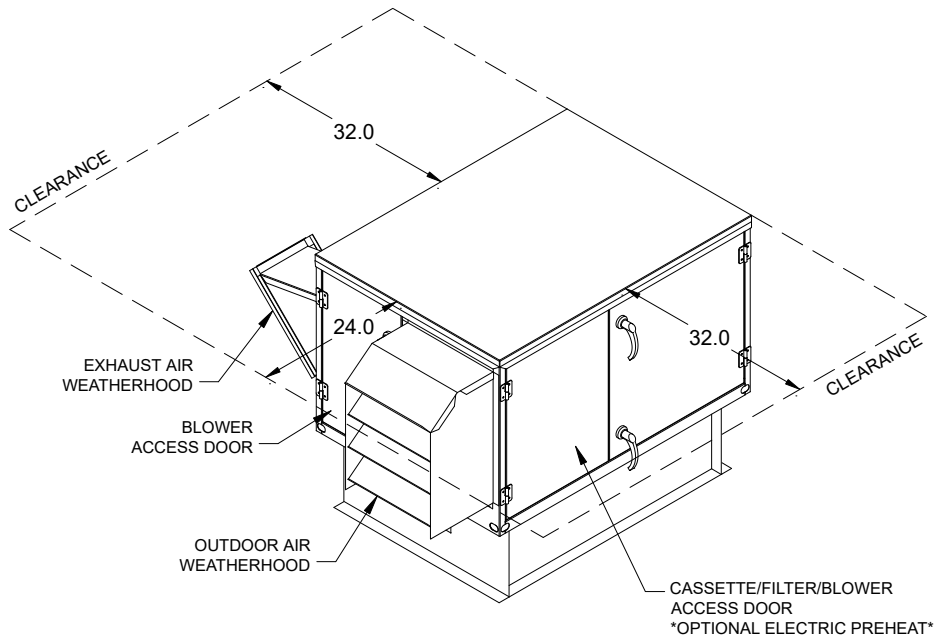

Front Left Isometric

Overview Drawings

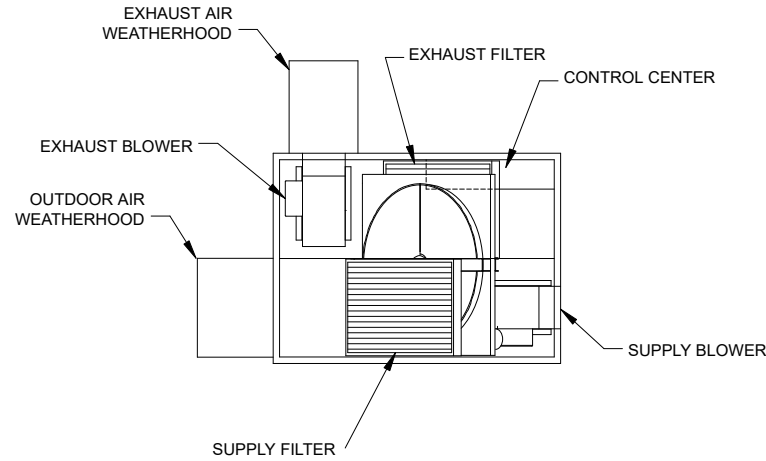

Plan

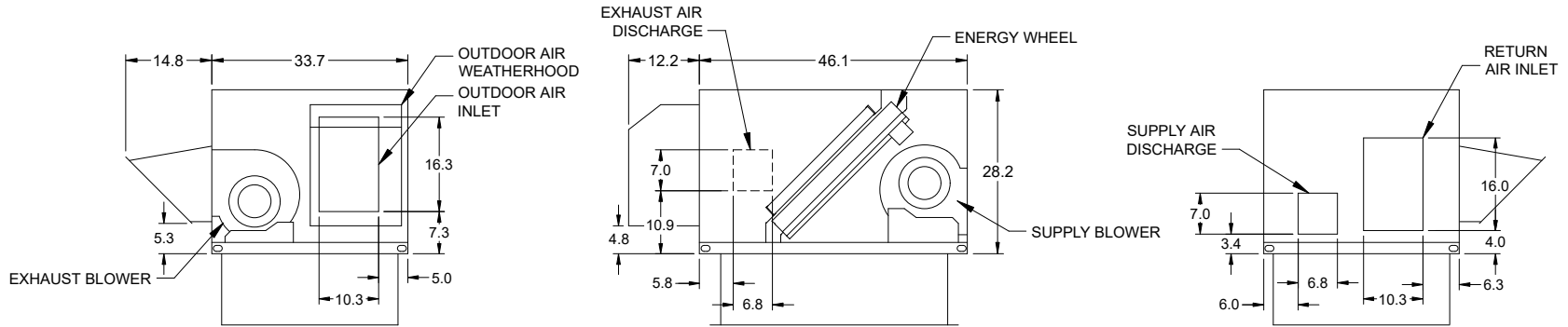

Left End

Elevation

Right End

Corner Weights

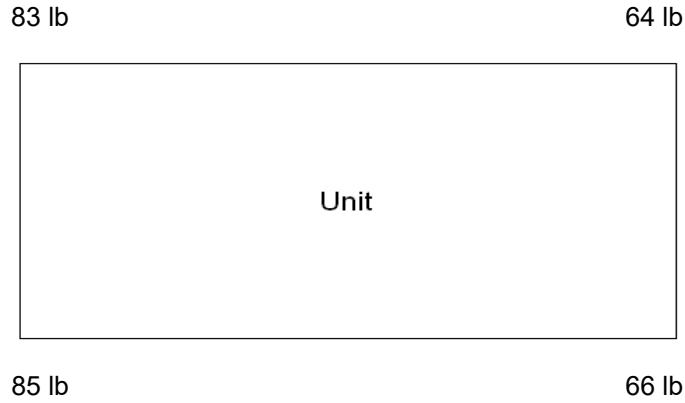

Note

Estimated corner weights are shown looking down on unit and the outside air intake will be on the left. Weights are applied at the base of the unit. Images not drawn to scale.

Terminal Strip Controls

BASIC UNIT CONTROLS:

The Energy Recovery Unit will be provided from the factory with an integral control center including: a single non-fused disconnect, 24 VAC transformer, terminal strip, fan contactors and overloads and energy wheel VFD.

ON/OFF CONTROL:

Within the unit control center, a digital signal must be field wired into the terminal strip (connecting terminals R and G) to control unit startup or shutdown.

This on/off signal is coming from:

By Others: The unit shall be energized by a field supplied and wired digital contact.

Startup (Digital Contact Closes)

- Exhaust fan ON.
- Supply fan ON.
- Energy Wheel is energized.

Shutdown (Digital Contact Opens)

- Supply fan, exhaust fan and energy wheel de-energized.

FROST CONTROL

Frost Control for the energy wheel is enabled when frost is present on the wheel; based on the outside air temperature and the pressure drop across the wheel. If the outdoor air temperature is below 5 F and the differential pressure across the wheel is above 1.5" frost control will enable.

Timed Exhaust:

When frosting has occurred, the supply blower is cycled (30 min. ON/ 5 min. OFF) to allow the warm exhaust air to defrost the wheel. Once either the pressure drop decreases below the pressure switch set point, or the outdoor air temperature increases above the temperature set point, the unit will resume normal operation.

ECONOMIZER SEQUENCE

Stop Wheel - Temperature:

When the application requires cooling (Digital call for cooling from the building or space, R->Y1), and the outdoor air conditions are suitable for free cooling the energy wheel will be de-energized. When the space cooling is satisfied, or the outdoor air temperature is not suitable for free cooling, the wheel will resume normal operation. The economizer will be locked out when the outdoor air is < 50 F (adj.) or > 65 F (adj.)

Wiring Diagram

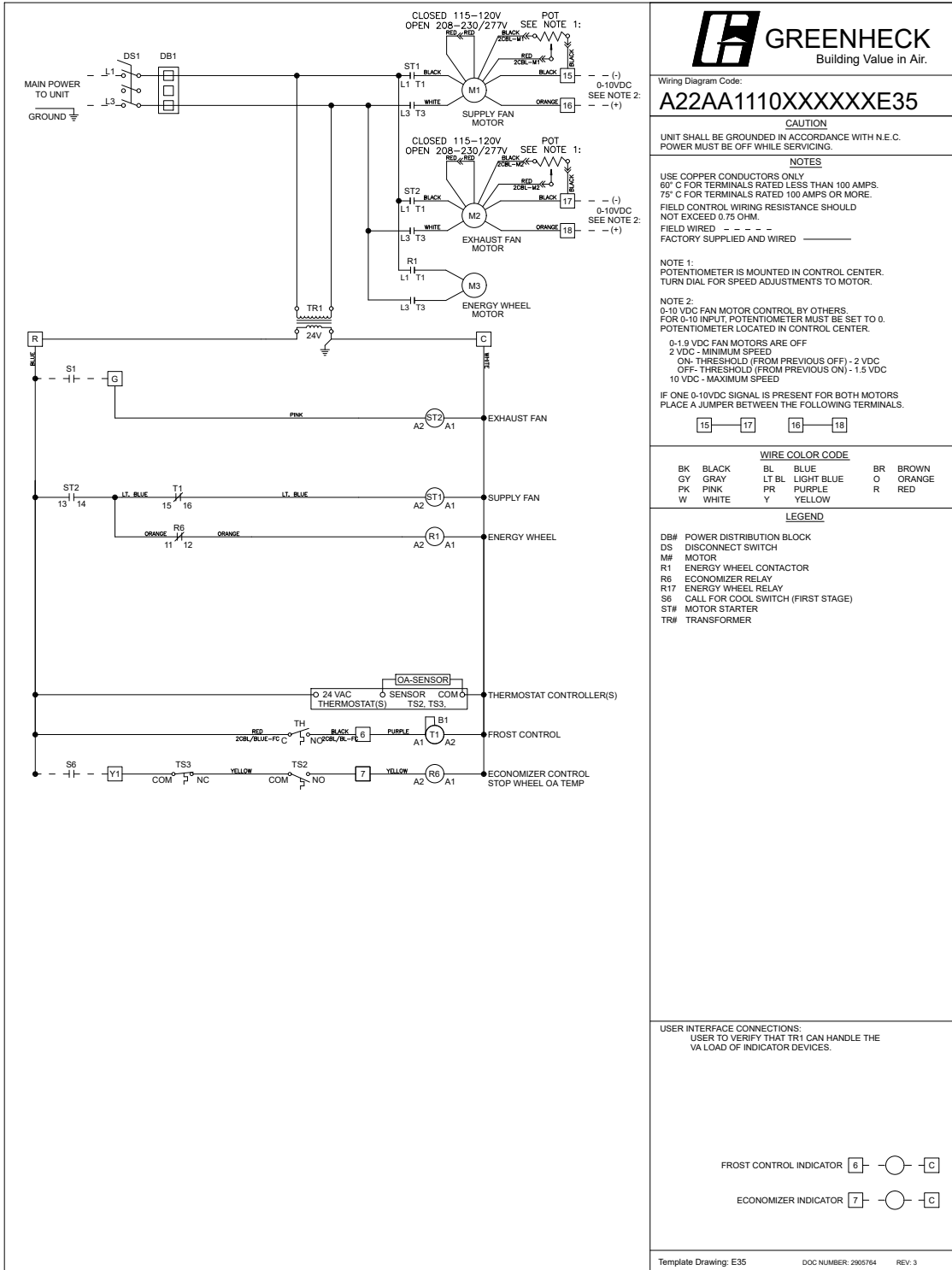

Warranty Statement for ERV Preconditioners

Unit Warranty

Greenheck warrants the equipment to be free from defects in material and workmanship for a period of 18 months from the date of shipment. Initial startup must be completed within six months of the shipment date, and a startup report must be submitted to Greenheck.

Energy Wheel Warranty

The energy recovery wheel is warranted to be free from defects in material and workmanship for a period of 5 years from the shipment date. This warranty applies to all parts and components in the energy recovery cassettes with the exception of the motor.

Warranty Notes

Any component which proves defective during the warranty period will be repaired or replaced at Greenheck's sole option when returned to our factory, transportation prepaid. All warranties do not include labor costs associated with troubleshooting, removal, or installation. Greenheck will not be liable for any consequential, punitive, or incidental damages resulting from use, repair, or operation of any Greenheck product. These warranties are exclusive and are in lieu of all other warranties, whether written, oral, or implied, including the warranty of merchantability and the warranty of fitness for a particular purpose. No person (including any agent or salesperson) has authority to expand Seller's obligation beyond the terms of this warranty, or to state that the performance of the product is other than that published by Seller.

As a result of our commitment to continuous improvement, Greenheck reserves the right to change specifications without notice.

GKD Roof Curb

Model: GKD-30.5/42.5-G14

Curb Height (in.)	Curb Length (in.)	Curb Width (in.)	Material	Finish Type	Duct Adapter	Curb Weight (lb)
14	42.5	30.5	Galvanized	Galvanized	Yes	50

Standard Construction Features:
All dimensions shown in inches.
Weight shown is within +/-5%.
If unit is selected with side or end discharge/return, there will not be bottom connections supplied with the curb.
18 gauge galvanized steel (perimeter channels).
18 gauge galvanized steel (interior channels).
Ships knocked down for field assembly.
Curb insulation to be provided by others.

**Top View
of Curb**

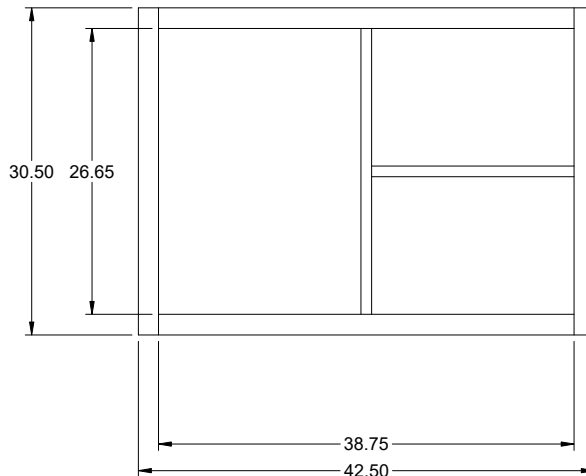

**Cross-Section
View of Unit
on Curb**

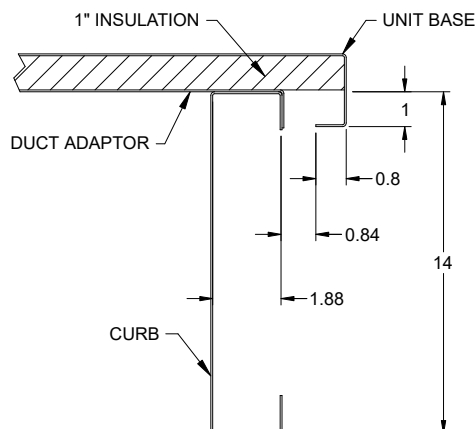

ERVe-20-15L

Unit Performance

Design Conditions					
Elevation (ft)	Summer		Winter DB (F)	Outdoor Air (CFM)	Exhaust Air (CFM)
	DB (F)	WB (F)			
981	92.0	74.0	13.0	1,450	1,450

Unit Specifications			
Qty	Weight (lb)	Unit Installation	Unit ETL Listing
1	897 (+/- 5%)	Outdoor	UL-1812

Configuration			
Outdoor Air		Exhaust Air	
Intake	Discharge	Intake	Discharge
End	End	End	Side

Energy Recovery Performance									
Design Condition	Temperature (F)								Capacity Reduction (BTU/h)
	Outdoor Air		Supply Air		Return Air		Exhaust Air		
	DB	WB	DB	WB	DB	WB/RH	DB	WB	
Summer	92.0	74.0	78.3	65.3	75.0	62.4/50	88.5	71.6	48,938.0
Winter	13.0	10.3	59.5	47.7	72.0	55.6/35	24.5	22.8	73,426.0

Air Performance							
Type	Total Volume (CFM)	External SP (in. wg)	Total SP (in. wg)	FRPM	Fan		
					Qty	Type	Drive-Type
Supply	1,450	0.75	0.85	1346	1	Forward Curve	Belt
Exhaust	1,450	0.64	0.784	1310	1	Forward Curve	Belt

Motor Specifications						
Motor	Qty	Operating Power (hp)	Size (hp)	Enclosure	Efficiency	RPM
Supply	1	0.61	3/4	ODP	SE	1725
Exhaust	1	0.58	3/4	ODP	SE	1725

Electrical Specifications					
Power Supply	Rating (V/C/P)	MCA (A)	MOP (A)	Fan Power (W/CFM)*	SCCR
Unit	208/60/1	17.6	25.0	0.616	5kA

*Fan Power (W/CFM) = (Supply BHP + Exhaust BHP) / Supply CFM

Construction Features And Accessories

Unit	
UL-1812	Std
Unit Installation - Outdoor	Std
Outdoor Air Filters - 2" MERV 8, 2-20x20	Std
Exhaust Air Filters - 2" MERV 8, 2-20x20	Std
Energy Recovery Device - Polymer Wheel w/ Silica Gel Desiccant	Std
Unit Construction - Double Wall	Std
Insulation - 1 inch 3# R4 fiberglass	Std
Corrosion Resistant Fasteners	Std
Access - Hinged	Std
Unit Finish - Galvanized	Std
Fan VFDs	
Single Point Power	Std
Factory Wired Non-Fused Disconnect Switch	Std
Supply Weatherhood: Downturn	Std
Exhaust Weatherhood: Downturn	Std
Fan Vibration Isolation - Neoprene	Std
Controls	
Unit Controls - Terminal Strip	X
Sensors	
Unit On/Off Control - By Others	X
Sensor Monitoring Package	
Heating Enable - None	
Cooling Enable - None	
Supply Fan Control	
Exhaust Fan Control	
Network Protocol	
Energy Wheel Economizer Control - Stop Wheel, Temperature	X
Exhaust Only Operation	
Remote Panel	
Control Accessories	
Remote Display	
CO2 Sensor	
Dirty Filter Sensor(s)	
Airflow Monitoring - None	
Wheel Rotation Sensor	

Accessories	
Frost Control - Timed Exhaust	X
Service Outlet - 120 VAC GFCI Service Outlet, Shipped Loose	
Spare Filters	
Spare Energy Wheel Segments	
Spare Fan Belts	
Shipped Loose Smoke Detectors	
Outdoor Air Damper	
Return Air Damper	
Roof Curb - GKD - 40.35/61.1-G14	X
Spare Energy Wheel Belt	
Warranty Options	
Unit Warranty - 18 Months (Std.)	Std
Energy Wheel Warranty - 5 Yrs Less Motor	Std

Standard Option	Std
Not Included	
Included	X

Notes

A backdraft damper is included as an integral part of the exhaust weatherhood assembly.

Supply Fan Charts And Performance

Supply Fan Performance									
Total Volume (CFM)	External SP (in. wg)	Total SP (in. wg)	RPM	Operating Power (hp)	Motor		Fan		
					Qty	Size (hp)	Qty	Type	Drive-Type
1,450	0.75	0.85	1346	0.61	1	3/4	1	Forward Curve	Belt

Pressure Drop (in. wg)				
Weatherhood	Filter	Damper	External	Total
-	0.1	-	0.75	0.85

Sound Performance in Accordance with AMCA										
Sound Power by Octave Band								Lwa	dBA	Sones
62.5	125	250	500	1000	2000	4000	8000			
68.4	62.5	55.9	54.1	56.5	55.6	52.6	47.3	61.6	50.1	5.5

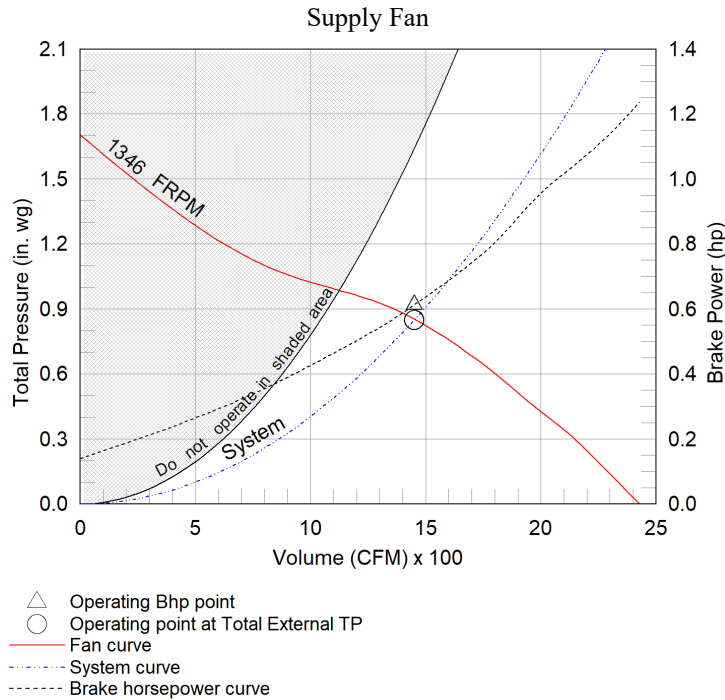

Exhaust Fan Charts And Performance

Exhaust Fan Performance									
Total Volume (CFM)	External SP (in. wg)	Total SP (in. wg)	RPM	Operating Power (hp)	Motor		Fan		
					Qty	Size (hp)	Qty	Type	Drive-Type
1,450	0.64	0.784	1310	0.58	1	3/4	1	Forward Curve	Belt

Pressure Drop (in. wg)				
Weatherhood	Filter	Damper	External	Total
0.045	0.1	-	0.64	0.784

Sound Performance in Accordance with AMCA										
Sound Power by Octave Band								Lwa	dBA	Sones
62.5	125	250	500	1000	2000	4000	8000			
67.7	61.9	55.3	53.8	56.3	55.3	52.2	46.8	61.3	49.8	5.3

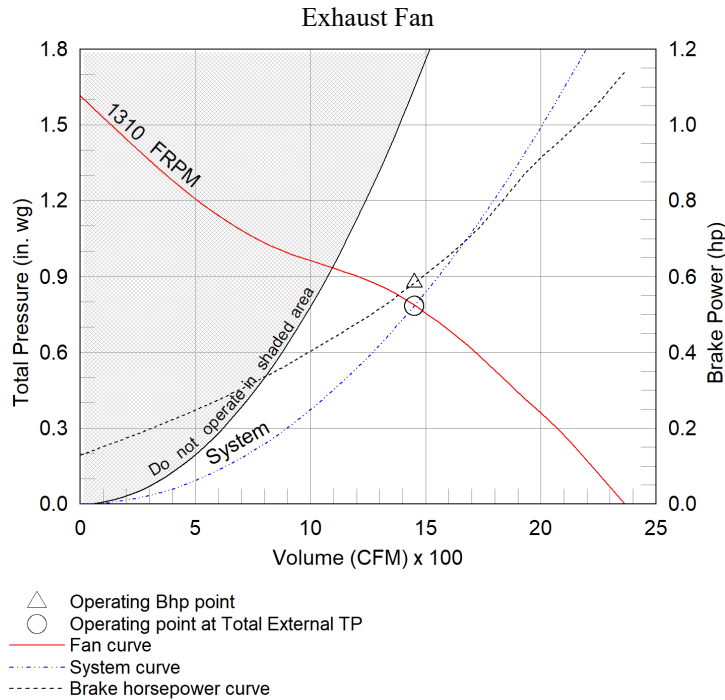

Energy Recovery Summer Performance

Outdoor Air		Supply Air	
Dry Bulb (F)	92.0	Dry Bulb (F)	78.3
Wet Bulb (F)	74.0	Wet Bulb (F)	65.3
Specific Humidity (gr/lb)	103	Specific Humidity (gr/lb)	76
Enthalpy (BTU/lb)	38.2	Enthalpy (BTU/lb)	30.7
Exhaust Air		Return Air	
Dry Bulb (F)	88.5	Dry Bulb (F)	75.0
Wet Bulb (F)	71.6	Rel. Humidity (%)	50
Specific Humidity (gr/lb)	93	Specific Humidity (gr/lb)	67
Enthalpy (BTU/lb)	35.8	Enthalpy (BTU/lb)	28.5

Design Air Flow Conditions			
OA Volume (CFM)	ASHRAE 90.1 OA Enthalpy Recovery Ratio	EA Volume (CFM)	EA Wheel Effectiveness
1,450	77.4	1,450	76.2

Outdoor Air Cooling Reduction				
OA Load w/o Energy Recovery		OA Load with Energy Recovery		Equipment Reduction (tons)
(BTU/h)	(tons)	(BTU/h)	(tons)	
63,293.0	5.27	14,355.0	1.20	4.08

Summer Conditions

- 1 = Outdoor Air Design
- 2 = Energy Wheel
- 3 = Exhaust Air Entering Wheel

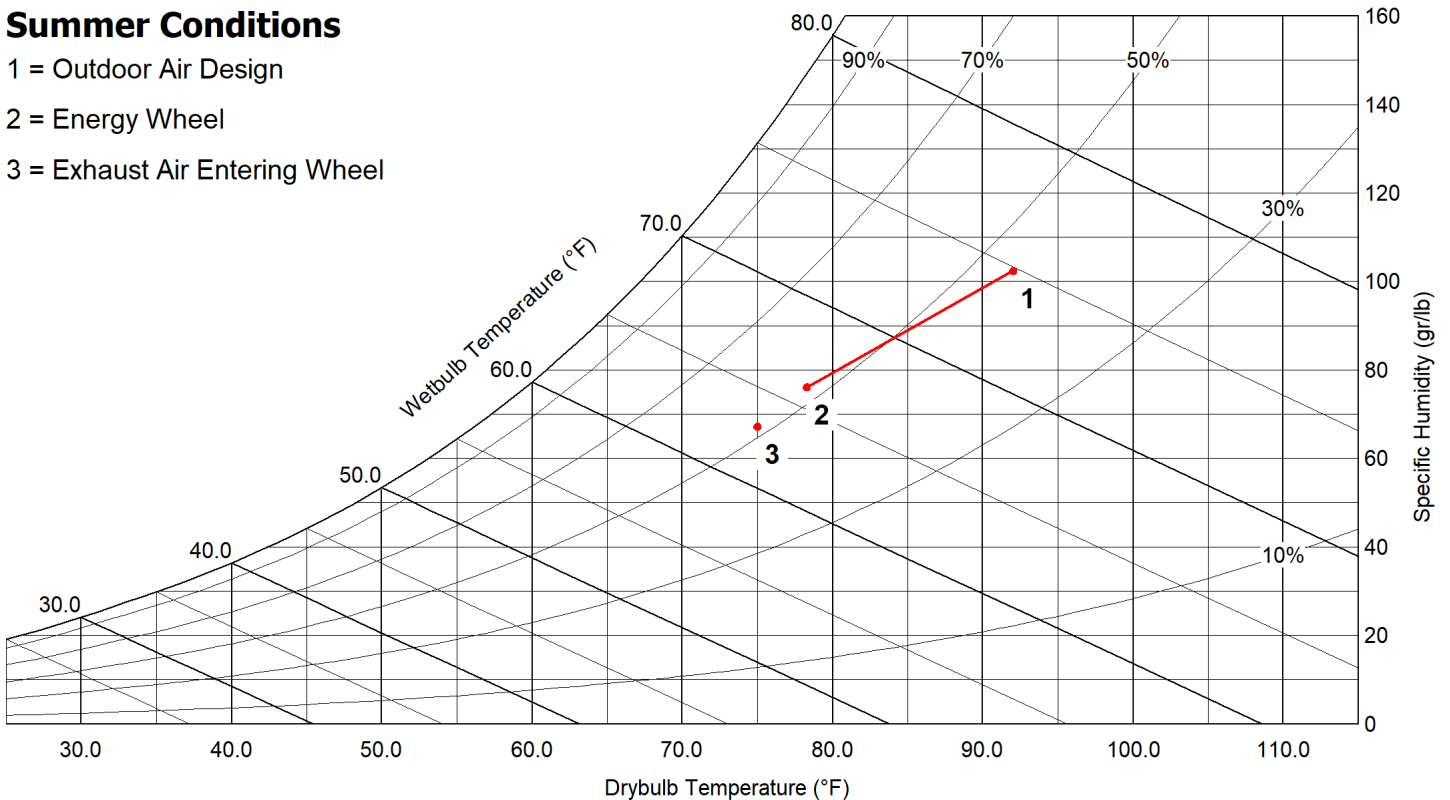

Energy Recovery Winter Performance

Outdoor Air		Supply Air	
Dry Bulb (F)	13.0	Dry Bulb (F)	59.5
Wet Bulb (F)	10.3	Wet Bulb (F)	47.7
Specific Humidity (gr/lb)	6	Specific Humidity (gr/lb)	32
Enthalpy (BTU/lb)	4.0	Enthalpy (BTU/lb)	19.2
Exhaust Air		Return Air	
Dry Bulb (F)	24.5	Dry Bulb (F)	72.0
Wet Bulb (F)	22.8	Rel. Humidity (%)	35
Specific Humidity (gr/lb)	15	Specific Humidity (gr/lb)	42
Enthalpy (BTU/lb)	8.2	Enthalpy (BTU/lb)	23.9

Design Air Flow Conditions			
OA Volume (CFM)	ASHRAE 90.1 OA Enthalpy Recovery Ratio	EA Volume (CFM)	EA Wheel Effectiveness
1,450	76.7	1,450	78

Outdoor Air Heating Reduction			
OA Load w/o Energy Recovery (BTU/h)	OA Load with Energy Recovery (BTU/h)	Equipment Reduction (BTU/h)	Sensible Effectiveness (%)
93,164.0	19,738.0	73,426.0	80.8

Winter Conditions

- 1 = Outdoor Air Design
- 2 = Energy Wheel
- 3 = Exhaust Air Entering Wheel

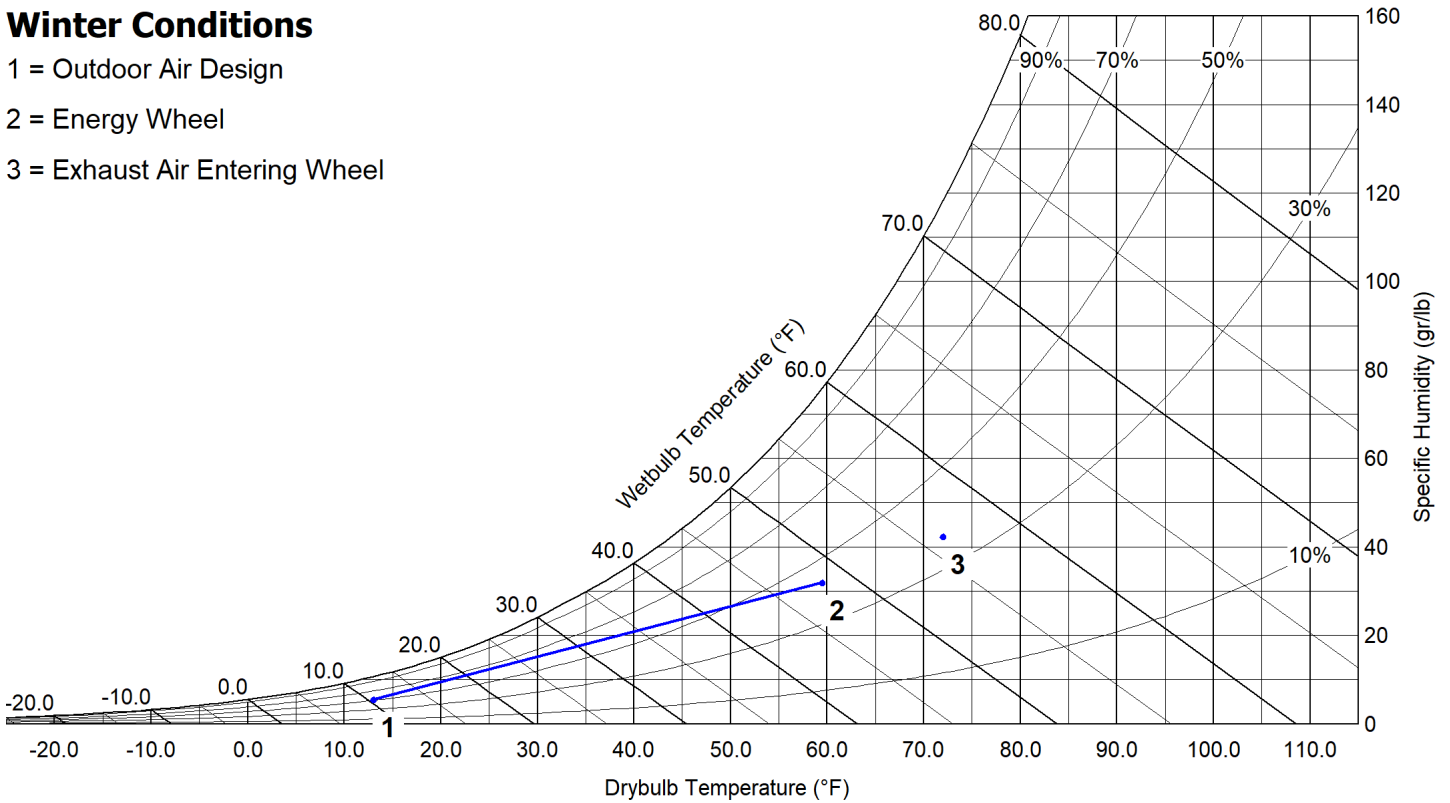

AHRI Performance Ratings

Energy Recovery Performance Rating in accordance with AHRI Standard 1060 (I-P)							
Rated Airflow (SCFM)		Net Supply Airflow (SCFM)	EATR (%)	OACF	Pressure Drop (in. wg)		Purge Angle (degrees)
Leaving Supply	Entering Exhaust				Supply	Exhaust	
1495	1495	1450	3	1.04	0.97	0.97	0

Thermal Effectiveness Ratings							
Enthalpy Recovery Ratio (%)		Sensible Effectiveness (%)		Latent Effectiveness (%)		Total Effectiveness (%)	
Summer	Winter	Summer	Winter	Summer	Winter	Summer	Winter
77.4	76.7	80.5	80.8	74	73.9	76.2	78

Note(s)

Summer Design Conditions:
Certified in accordance with the AHRI ERV Certification Program, which is based on AHRI Standard 1060. Certified units may be found in the AHRI Directory at www.ahridirectory.org.



Winter Design Conditions:
Application Rating is outside the scope of AHRI ERV Certification Program, but is rated in accordance with AHRI Standard 1060.

Energy Saving Analysis

Design Conditions									
Volume (CFM)		OA Enthalpy Recovery Ratio (%)		Outdoor (DB/WB)		Indoor (DB)		Relative Humidity (%)	
Supply	Exhaust	Summer	Winter	Summer	Winter	Summer	Winter	Summer	Winter
1,450	1,450	77.4	76.7	92.0 / 74.0	13.0 / 10.3	75.0	72.0	50.0	35.0

Cooling Analysis		
Cooling Range (F)	Total Hours Annually	Enthalpy (BTU/lb)
112.5	0	0.0
107.5	0	0.0
102.5	3	34.6
97.5	9	37.5
92.5	64	39.0
87.5	176	37.4
82.5	410	35.0
77.5	354	32.8
72.5	260	30.2

Heating Analysis	
Heating Range (F)	Total Hours Annually
62.5	252
57.5	273
52.5	214
47.5	209
42.5	170
37.5	171
32.5	129
27.5	74
22.5	52
17.5	17
12.5	4
7.5	0
2.5	0
-2.5	0
-7.5	0
-12.5	0
-17.5	0

Energy Savings				
	Load w/o Energy Recovery (BTU)	Load with Energy Recovery (BTU)	Annual Savings (BTU)	Annual Savings (USD)
Cooling	45,476,638	10,277,720	35,198,918	374
Heating	61,150,291	13,819,965	47,330,326	539
Energy Savings Cost				\$913

Notes				
Location	Operating Time	Electric Cost (USD)	Heat Source	Heating Cost (USD)
Knoxville Mcghee Tyson Airport, TN (United States)	12 hours/day, 5 days/week	0.08	Gas	0.8

Isometric Drawings

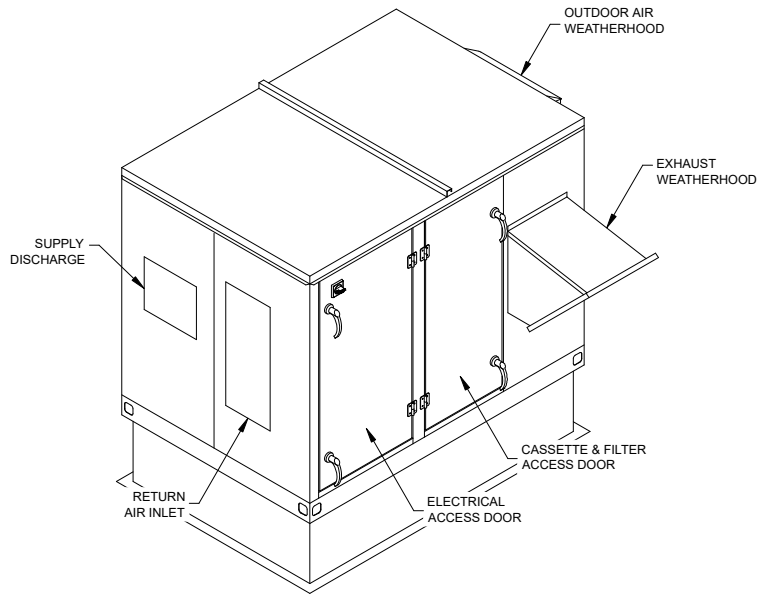

Back Right Isometric

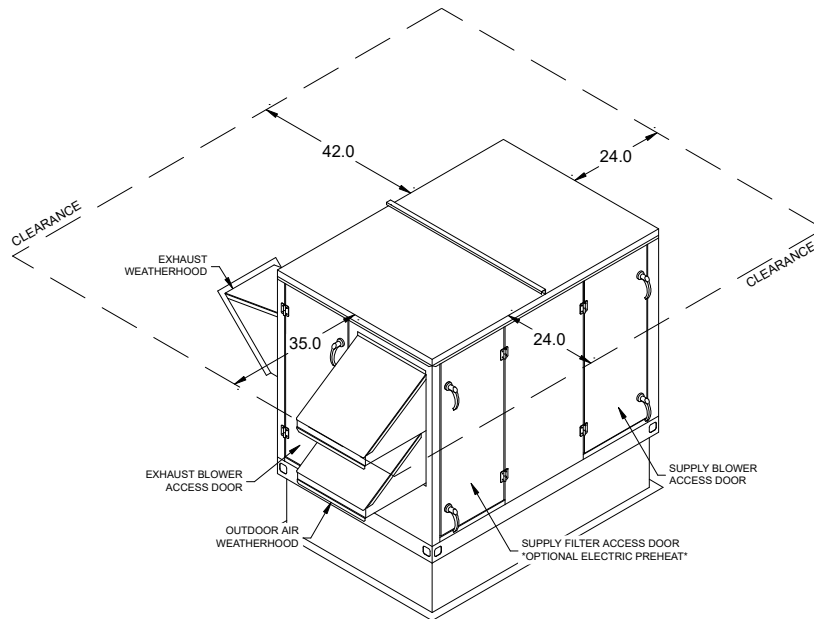

Front Left Isometric

Overview Drawings

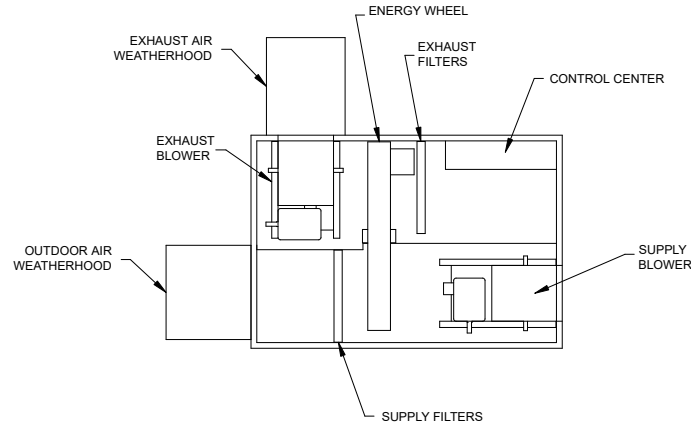

Plan

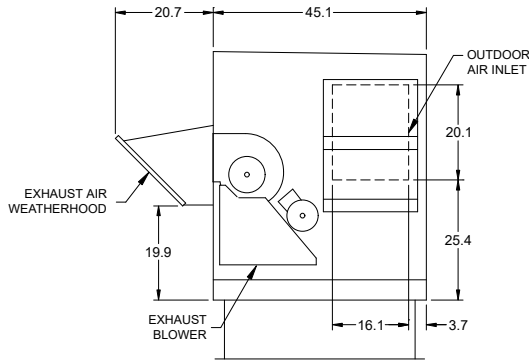

Left End

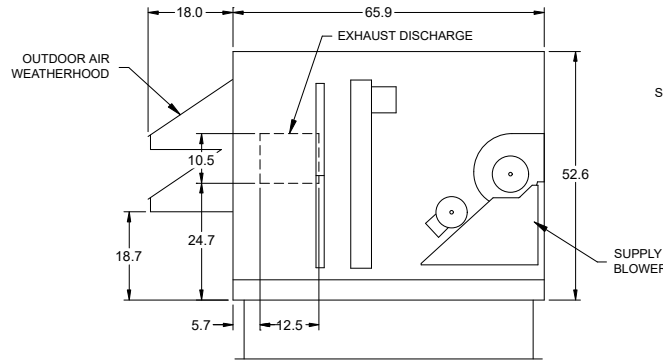

Elevation

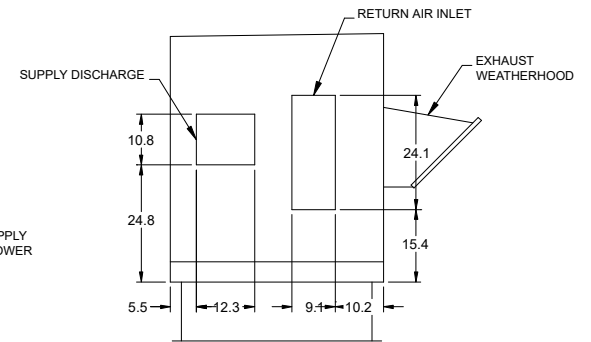

Right End

Corner Weights

242 lb

209 lb

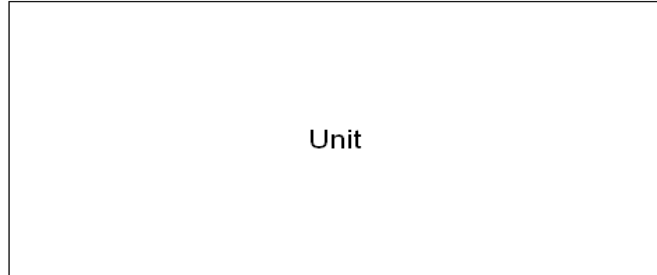

239 lb

207 lb

Note

Estimated corner weights are shown looking down on unit and the outside air intake will be on the left. Weights are applied at the base of the unit. Images not drawn to scale.

Terminal Strip Controls

BASIC UNIT CONTROLS:

The Energy Recovery Unit will be provided from the factory with an integral control center including: a single non-fused disconnect, 24 VAC transformer, terminal strip, fan contactors and overloads and energy wheel VFD.

ON/OFF CONTROL:

Within the unit control center, a digital signal must be field wired into the terminal strip (connecting terminals R and G) to control unit startup or shutdown.

This on/off signal is coming from:

By Others: The unit shall be energized by a field supplied and wired digital contact.

Startup (Digital Contact Closes)

- Exhaust fan ON.
- Supply fan ON.
- Energy Wheel is energized.

Shutdown (Digital Contact Opens)

- Supply fan, exhaust fan and energy wheel de-energized.

FROST CONTROL

Frost Control for the energy wheel is enabled when frost is present on the wheel; based on the outside air temperature and the pressure drop across the wheel. If the outdoor air temperature is below 5 F and the differential pressure across the wheel is above 1.5" frost control will enable.

Timed Exhaust:

When frosting has occurred, the supply blower is cycled (30 min. ON/ 5 min. OFF) to allow the warm exhaust air to defrost the wheel. Once either the pressure drop decreases below the pressure switch set point, or the outdoor air temperature increases above the temperature set point, the unit will resume normal operation.

ECONOMIZER SEQUENCE

Stop Wheel - Temperature:

When the application requires cooling (Digital call for cooling from the building or space, R->Y1), and the outdoor air conditions are suitable for free cooling the energy wheel will be de-energized. When the space cooling is satisfied, or the outdoor air temperature is not suitable for free cooling, the wheel will resume normal operation. The economizer will be locked out when the outdoor air is < 50 F (adj.) or > 65 F (adj.)

Wiring Diagram

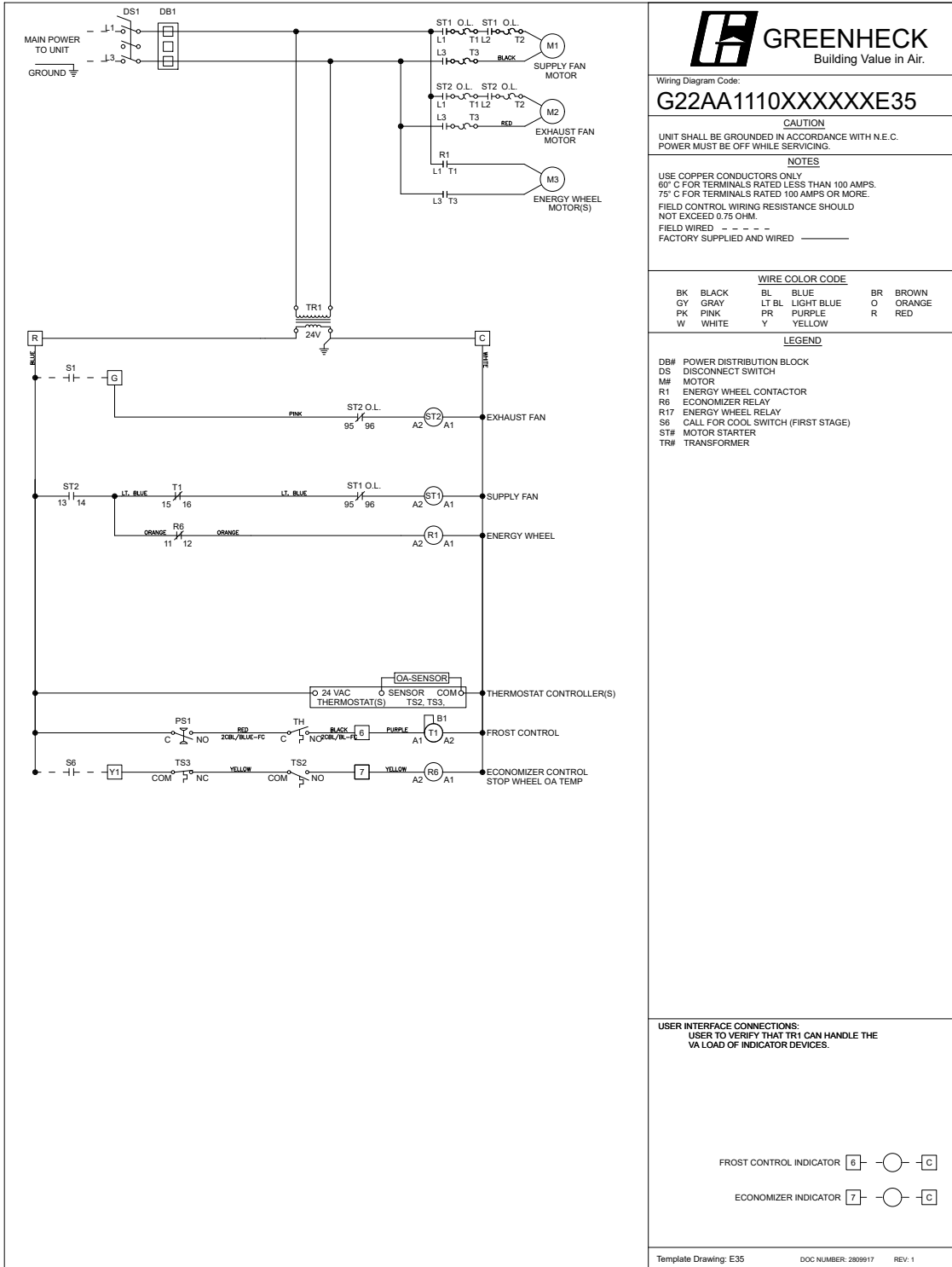

Warranty Statement for ERV Preconditioners

Unit Warranty

Greenheck warrants the equipment to be free from defects in material and workmanship for a period of 18 months from the date of shipment. Initial startup must be completed within six months of the shipment date, and a startup report must be submitted to Greenheck.

Energy Wheel Warranty

The energy recovery wheel is warranted to be free from defects in material and workmanship for a period of 5 years from the shipment date. This warranty applies to all parts and components in the energy recovery cassettes with the exception of the motor.

Warranty Notes

Any component which proves defective during the warranty period will be repaired or replaced at Greenheck's sole option when returned to our factory, transportation prepaid. All warranties do not include labor costs associated with troubleshooting, removal, or installation. Greenheck will not be liable for any consequential, punitive, or incidental damages resulting from use, repair, or operation of any Greenheck product. These warranties are exclusive and are in lieu of all other warranties, whether written, oral, or implied, including the warranty of merchantability and the warranty of fitness for a particular purpose. No person (including any agent or salesperson) has authority to expand Seller's obligation beyond the terms of this warranty, or to state that the performance of the product is other than that published by Seller.

As a result of our commitment to continuous improvement, Greenheck reserves the right to change specifications without notice.

GKD Roof Curb

Model: GKD-40.35/61.1-G14

Curb Height (in.)	Curb Length (in.)	Curb Width (in.)	Material	Finish Type	Duct Adapter	Curb Weight (lb)
14	61.1	40.35	Galvanized	Galvanized	Yes	86

Standard Construction Features:
All dimensions shown in inches.
Weight shown is within +/-5%.
If unit is selected with side or end discharge/return, there will not be bottom connections supplied with the curb.
18 gauge galvanized steel (perimeter channels).
18 gauge galvanized steel (interior channels).
Ships knocked down for field assembly.
Curb insulation to be provided by others.

**Top View
of Curb**

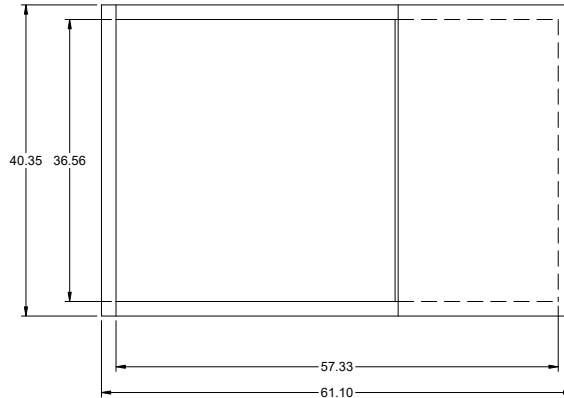

**Cross-Section
View of Unit
on Curb**

