



Lennox National Accounts Project Submittal

Project Name: Barnes & Noble #2118 - Huntersville, NC
Project Number: 866449
Project Altitude: 692
Project Location:
8725 TOWNLEY ROAD
HUNTERSVILLE, North Carolina US

Date: 5/23/2025
Quote: 582970A
Roof Top Units: 8
Split Systems: 0

Customer: Barnes & Noble Inc
Engineer: Pending Engineer
National Account: Barnes & Noble Inc

Table of Contents

Tag	Qty	Model	Description
<u>RTU 1,2</u>	2	LGT180H5M	LGT180H5M-G 15T
<u>RTU 3,4</u>	2	LGT120H5E	LGT120H5E-G 10T
<u>RTU 5</u>	1	LGT120H5E	LGT120H5E-G 10T
<u>RTU 6</u>	1	LGT036H5E	LGT036H5E-G 3T
<u>RTU 7,8</u>	2	LGT060H5E	LGT060H5E-G 5T
<u>Miscellaneous Items</u>			

Revit® Building Information Modeling (BIM) - [Click here](#)

AutoCAD® Templates - [Click here](#)



Lennox National Accounts Project Submittal

Tag: RTU 1,2
 Model: LGT180H5M - LGT180H5M-G 15T

UNIT OVERVIEW

Voltage	IEER EER	MCA/MOCP (amp)	Gross Cooling Ttl/Sens (MBH)	Net Cooling Ttl/Sens (MBH)	Supply Air Flow (cfm)	ESP/TSP (in.WC)	EAT DB/WB (°F)	LAT DB/WB (°F)
460V 3Ph 60Hz	15.4 12	35 / 40	184.0 / 138.0	176.7 / 130.7	6,000	0.50 / 0.71	80.0 / 67.0	57.6 / 56.8

COOLING

Cooling Performance		Temperatures (DB/WB °F)	
Gross Cooling (Ttl/Sens)	184.0 / 138.0 MBH	Ambient	95.0
Net Cooling (Ttl/Sens)	176.7 / 130.7 MBH	Entering	80.0
Coil Moisture Removal	43.36 lb/hr	Total Leaving – (Coil)	57.6
System Moisture Removal	43.36 lb/hr	Total Leaving – (Unit)	58.8
			56.8
			57.3

ARI Performance		Compressors		Refrigerant		Condensate Drain	
ARI Cooling	176.0 / 172.0 MBH	Cooling Stages	3.0	Type	R-454B	Qty	1
ARI Power	14,300 W	Compressor Qty	3	Charge	16 LBS. 6 OZ.	Size	1 in.
		Compressor RLA	19.8 amp			Pipe Thread	FPT

HEATING

Heating Performance		Temperatures (DB/WB °F)		Specifications	
Output (High/Low)	389.0 / 126.0 MBH	Total Leaving	60.0	Heat Stages	2
Input (High/Low)	480.0 / 156.0 MBH			Thermal Efficiency	81.0%
Gas Heat Rise	60.0 °F			Gas Line Size	1 in.
				Gas Pressure	7 in.WC

VENTILATION

Air Flow (cfm)		Supply Fan		Air Resistance (in.WC)	
Supply	6,000	Nominal Power	3.00 hp	Total	0.71
		Required Power	2.40 hp	Ext Supply	0.50
		Drive Type	MSAV Belt Drive		
		RPM Range	710 - 965 rpm		
		Required RPM	751 rpm		
		Exh Fan Nom HP	0.33 hp		

AIR RESISTANCE - OPTIONS/ACCESSORIES (in.WC)

Wet Coil	Humiditrol	Heat	Economizer	Filters	Diffuser	Exhaust	ERW
0.03		0.15		0.03			

ELECTRICAL

Voltage	460V 3Ph / 60Hz	Compressor RLA	19.8 amp
MCA	35 amp	Condenser FLA	5.4 amp
MOCP	40 amp	Supply Fan FLA	4.8 amp
Oper Range-Nom Volt	+/- 10%	Exh Fan Mtr FLACooling FLA	1.3 amp
		Total	32.6 amp

ADDITIONAL DATA

Cabinet	132.62 in. x 91.12 in. x 54.25 in.	Total Weight	2,451 lb
Downflow Supply	20.0 in. x 28.0 in.	Base Unit Net Weight	2,128 lb
Downflow Return	15.0 in. x 60.5 in.	OAS/Econ Weight	197 lb
Filters	(6) 24.0 in. x 24.0 in. x 2.0 in.	Exhaust Weight	62 lb
Sound Rating	93 dBA	Gas Heat Weight	64 lb



Lennox National Accounts Project Submittal

Tag: RTU 1,2

Factory Installed Options

High Performance Economizer Factory Installed
 Single Enthalpy High Performance Economizer
 Belt Drive
 Unit Orientation Downflow
 Supply Fan: Multi-Stage Air Volume Belt
 440V/460V/480V 3Phase
 80Amp Non-Fused Disconnect Factory Installed
 Built-in BACnet IP and MS/TP (standard)
 Refrigerant R-454B
 Supply Motor - 3.0 Hp Std- w/ MSAV
 Supply Drive Kit 2 (710-965 RPM)
 Std Static Power Exhaust Fan Factory Installed
 480K A.S. (Dual Stage)
 Hinged Access Doors Factory Installed
 15A GFCI Factory Installed/Field Wired
 Supply Air Smoke Detector Factory Installed
 Return Air Smoke Detector Factory Installed
 Environ Condenser Coil System Factory Installed
 Drain Pan Overflow Switch Factory Installed
 2" MERV8 - Filter Factory installed

Field Installed Accessories

Catalog Number	Qty	Description
23V86	2	CO2 Sensors - Wall-mount, white plastic cover, no display Field Installed
Y3027	2	BE RTS2-AOS Multi Signal Accessory

Product Features

Cabinet

Hinged Access Panels
 Durable Outdoor Enamel Paint Finish
 Totally Enclosed Outdoor Fan Motor
 PVC Coated Fan Guard
 Corrosion-Resistant Drain Pan
 Isolated Compressor Compartment

Cooling System

Scroll Compressor
 Expansion Valves
 High Capacity Driers
 Crankcase Heater
 System can operate from 0°F to 125°F without any additional controls
 Pre-charged Refrigeration System
 Timed Off Control
 Internal Pressure Relief Valve
 Building Automation Integrated Control - Up to 3 Stages of Cooling

Heating System

Redundant Automatic Gas Valve with Manual Shut-off
 Electronic Flame Sensor
 Direct Spark Ignition
 Inshot Burners
 AGA-CGA Certified

Control System

Fan and Limit Controls
 Overload Protection
 Microprocessor Controls – Lennox® CORE Control System
 Auto reset high & low pressure switch with strike 3 lockout feature in Lennox® CORE Control System
 Built-in BACnet IP & MS/TP
 Phase/Voltage Detection
 Return Air Sensor Factory Installed
 Outdoor Air Sensor Factory Installed



Lennox National Accounts Project Submittal

Factory Installed Discharge Air Sensor
Refrigerant Detection System (RDS) and mitigation response, per UL safety standard 60335-2-40
Blower Proving Switch

Compliance

Components are Bonded for Grounding
Factory Test Operated
All models are ASHRAE 90.1 energy efficiency compliant and meet or exceed requirements of Section 6.8
All models meet DOE 2023 energy efficiency standards
All models are compliant with and listed to UL standard 60335-2-40

Model meets California Code of Regulations, Title 24 and ASHRAE 90.1-2016 Section 6.4.3.10 requirements for staged airflow
Model meets HCAI (formerly OSHPD) OSP and Special Seismic Certification (Number: OSP-0596) and meet 2018 International Building Code (IBC), 2019 California Building Code (CBC) ASCE 7, and ICC-ES AC156
ISO 9001 Registered Manufacturing Quality System
Only refrigerants in compliance with New York State regulations can be used in the state of New York

Warranty

Limited warranty on aluminized heat exchanger of 10 years
Limited warranty on compressor of 5 years
Limited warranty on Environ Coil System of 3 years
Limited warranty on High Performance Economizer of 5 years
Limited warranty on all other components of 1 year
Limited warranty on Lennox® CORE Control System of 3 years
See Limited Warranty Certificate included with unit for details



Lennox National Accounts Project Submittal

Corner Weights (lb)								Center of Gravity (in.)			
AA		BB		CC		DD		EE		FF	
Base	Max	Base	Max	Base	Max	Base	Max	Base	Max	Base	Max
483	596	435	517	574	604	636	696	51.00	50.00	39.25	42.00

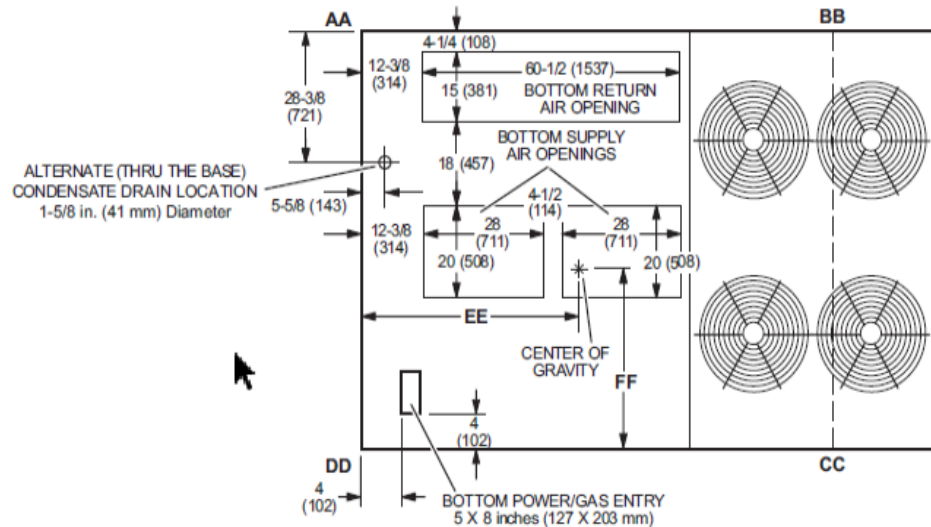

TOP VIEW

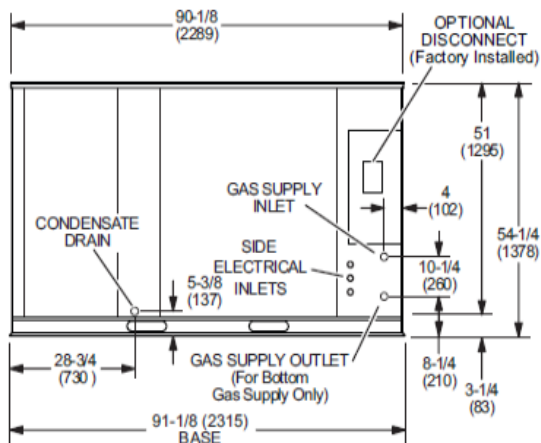

END VIEW

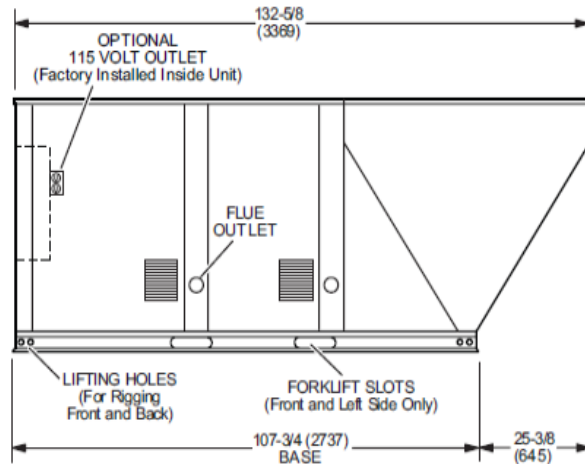

SIDE VIEW



Lennox National Accounts Project Submittal

OUTDOOR AIR HOOD DETAIL

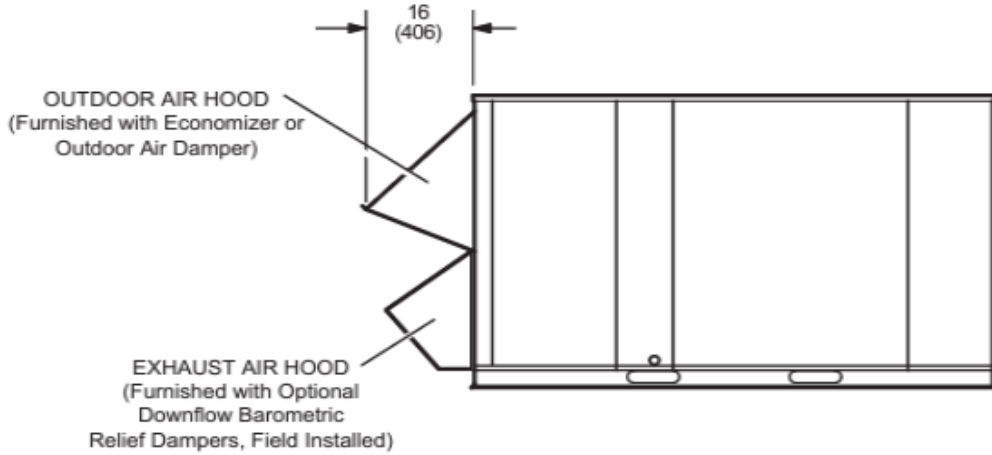

OPTIONAL HORIZONTAL BAROMETRIC RELIEF DAMPERS WITH HOOD (Field installed in horizontal return air duct adjacent to unit)

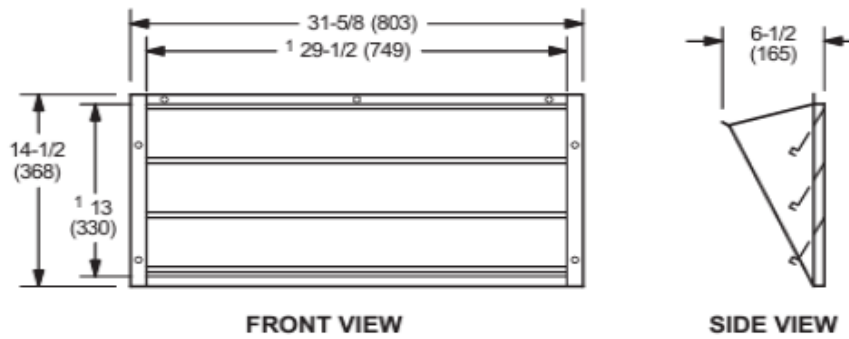

NOTE - Two furnished per order no.
1 NOTE - Opening size required in return air duct.



Lennox National Accounts Project Submittal

Unit With Economizer

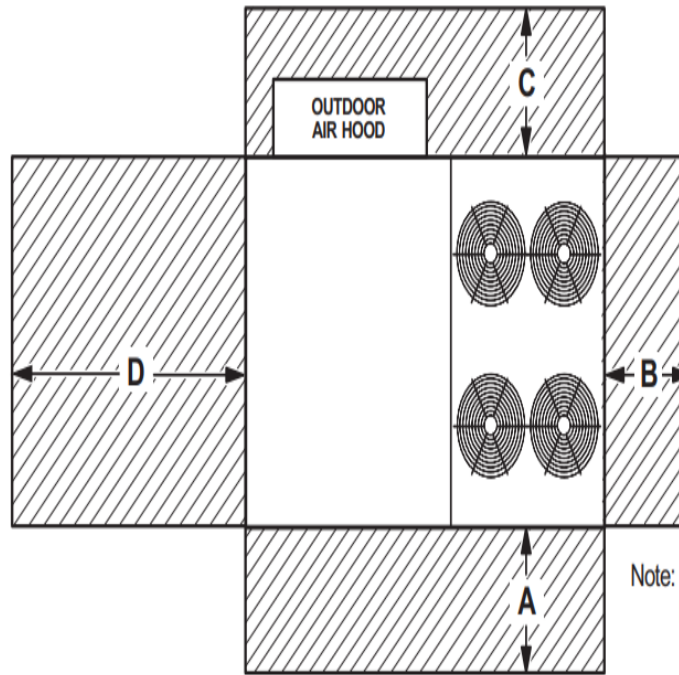

Note: Models with four outdoor fans shown.
Dimension clearances are for all sizes.

¹ Unit Clearance	A		B		C		D		Top Clearance
	in.	mm	in.	mm	in.	mm	in.	mm	
Service Clearance	60	1524	36	914	36	934	66	1676	Unobstructed
Clearance to Combustibles	36	914	1	25	1	25	1	25	
Minimum Operation Clearance	45	1143	36	914	36	914	41	1041	

NOTE - Entire perimeter of unit base requires support when elevated above the mounting surface.

¹ **Service Clearance** - Required for removal of serviceable parts.

Clearance to Combustibles - Required clearance to combustible material.

Minimum Operation Clearance - Required clearance for proper unit operation.



Lennox National Accounts Project Submittal

Tag: RTU 3,4
 Model: LGT120H5E - LGT120H5E-G 10T

UNIT OVERVIEW

Voltage	IEER EER	MCA/MOCP (amp)	Gross Cooling Ttl/Sens (MBH)	Net Cooling Ttl/Sens (MBH)	Supply Air Flow (cfm)	ESP/TSP (in.WC)	EAT DB/WB (°F)	LAT DB/WB (°F)
460V 3Ph 60Hz	16.1 12.1	25 / 30	125.7 / 91.8	119.2 / 85.2	4,000	0.50 / 1.14	80.0 / 67.0	57.7 / 56.5

COOLING

Cooling Performance		Temperatures (DB/WB °F)	
Gross Cooling (Ttl/Sens)	125.7 / 91.8 MBH	Ambient	95.0
Net Cooling (Ttl/Sens)	119.2 / 85.2 MBH	Entering	80.0 67.0
Coil Moisture Removal	31.99 lb/hr	Total Leaving – (Coil)	57.7 56.5
System Moisture Removal	31.99 lb/hr	Total Leaving – (Unit)	59.3 57.1

ARI Performance		Compressors		Refrigerant		Condensate Drain	
ARI Cooling	121.0 / 118.0 MBH	Cooling Stages	3.0	Type	R-454B	Qty	1
ARI Power	9,900 W	Compressor Qty	2	Charge	12 LBS. 2 OZ.	Size	1 in.
		Compressor RLA	14 amp			Pipe Thread	npt

HUMIDITROL - HOT GAS REHEAT

Humiditrol Dehumidification Performance		Temperatures (DB/WB °F)	
Gross Cooling - Stage 1(Ttl/Sens)	23.4 / 11.0 MBH	Ambient	95.0
Gross Cooling - Stage 2 (Ttl/Sens)	72.4 / 39.1 MBH	Entering	80.0 67.0
Moisture Removal - Stage 1	11.7 lb/hr	Total Leaving – (Stage 1)	77.3 65.2
Moisture Removal - Stage 2	31.4 lb/hr	Total Leaving – (Stage 2)	70.5 61.3

HEATING

Heating Performance		Temperatures (DB/WB °F)		Specifications	
Output (High/Low)	194.0 / 126.4 MBH	Total Leaving	44.9	Heat Stages	2
Input (High/Low)	240.0 / 156.0 MBH			Thermal Efficiency	81.0%
Gas Heat Rise	44.9 °F			Gas Line Size	0.75 in.
				Gas Pressure	7 in.WC

VENTILATION

Air Flow (cfm)		Supply Fan		Air Resistance (in.WC)	
Supply	4,000	Nominal Power	3.75 hp	Total	1.14
		Required Power	2.05 hp	Ext Supply	0.50
		Drive Type	ECM Direct Drive		
		Required Watts	1,526 W		
		Exh Fan Nom HP	0.33 hp		

AIR RESISTANCE - OPTIONS/ACCESSORIES (in.WC)

Wet Coil	Humiditrol	Heat	Economizer	Filters	Diffuser	Exhaust	ERW
0.14	0.05	0.22	0.19	0.04			

ELECTRICAL

Voltage	460V 3Ph / 60Hz	Compressor RLA	14.0 amp
MCA	25 amp	Condenser FLA	3.0 amp
MOCP	30 amp	Supply Fan FLA	4.3 amp
Oper Range-Nom Volt	+/- 10%	Exh Fan Mtr FLACooling FLA	1.3 amp22.6 amp
		Total	

ADDITIONAL DATA

Cabinet	101.25 in. x 60.12 in. x 46.88 in.	Total Weight	1,269 lb
Downflow Supply	20.0 in. x 28.0 in.	Base Unit Net Weight	1,100 lb
Downflow Return	24.0 in. x 27.0 in.	OAS/Econ Weight	86 lb
Filters	(4) 20.0 in. x 25.0 in. x 2.0 in.	Exhaust Weight	31 lb
Sound Rating	89 dBA	Humiditrol Weight	20 lb
		Gas Heat Weight	32 lb





Lennox National Accounts Project Submittal

Tag: RTU 3,4

Factory Installed Options

High Performance Economizer Factory Installed
 Single Enthalpy High Performance Economizer
 Direct Drive
 Unit Orientation Downflow
 Supply Fan: Multi-Speed ECM Direct Drive
 440V/460V/480V 3Phase
 80Amp Non-Fused Disconnect Factory Installed
 Built-in BACnet IP and MS/TP (standard)
 Refrigerant R-454B
 Supply Motor - 3.75 Hp - DirectPlus w/MSAV
 Std Static Power Exhaust Fan Factory Installed
 240K A.S. (Dual Stage)
 Hinged Access Doors Factory Installed
 15A GFCI Factory Installed/Field Wired
 Dirty Filter Switch Factory Installed
 Supply Air Smoke Detector Factory Installed
 Return Air Smoke Detector Factory Installed
 Environ Condenser Coil System Factory Installed
 Humiditrol Factory Installed
 2" MERV8 - Filter Factory installed

Field Installed Accessories

Catalog Number	Qty	Description
17M50	2	Humidity Sensor Kit Field Installed
23V86	2	CO2 Sensors - Wall-mount, white plastic cover, no display Field Installed
Y3027	2	BE RTS2-AOS Multi Signal Accessory

Product Features

Cabinet

Hinged Access Panels
 Durable Outdoor Enamel Paint Finish
 Totally Enclosed Outdoor Fan Motor
 PVC Coated Fan Guard
 Corrosion-Resistant Removable, Reversible Drain Pan
 Isolated Compressor Compartment

Cooling System

Scroll Compressor
 Expansion Valves
 High Capacity Driers
 Crankcase Heater
 System can operate from 0°F to 125°F without any additional controls
 Pre-charged Refrigeration System
 Timed Off Control
 Internal Pressure Relief Valve
 Humiditrol - Hot Gas Reheat Dehumidification System

Heating System

Redundant Automatic Gas Valve with Manual Shut-off
 Electronic Flame Sensor
 Direct Spark Ignition
 Inshot Burners
 AGA-CGA Certified
 If configured for room sensor control, additional staging may be possible. Refer to performance tables within the EHB

Control System

Fan and Limit Controls
 Overload Protection
 Microprocessor Controls – Lennox® CORE Control System
 Auto reset high & low pressure switch with strike 3 lockout feature in Lennox® CORE Control System
 Built-in BACnet IP & MS/TP
 Phase/Voltage Detection



Lennox National Accounts Project Submittal

Return Air Sensor Factory Installed
Outdoor Air Sensor Factory Installed
Factory Installed Discharge Air Sensor
Refrigerant Detection System (RDS) and mitigation response, per UL safety standard 60335-2-40

Compliance

Components are Bonded for Grounding
Factory Test Operated
All models are ASHRAE 90.1 energy efficiency compliant and meet or exceed requirements of Section 6.8
All models meet DOE 2023 energy efficiency standards
All models are compliant with and listed to UL standard 60335-2-40

Model meets California Code of Regulations, Title 24 and ASHRAE 90.1-2016 Section 6.4.3.10 requirements for staged airflow
Model meets HCAI (formerly OSHPD) OSP and Special Seismic Certification (Number: OSP-0596) and meet 2018 International Building Code (IBC), 2019 California Building Code (CBC) ASCE 7, and ICC-ES AC156
ISO 9001 Registered Manufacturing Quality System
Only refrigerants in compliance with New York State regulations can be used in the state of New York

Warranty

Limited warranty on aluminized heat exchanger of 10 years
Limited warranty on compressor of 5 years
Limited warranty on Environ Coil System of 3 years
Limited warranty on High Performance Economizer of 5 years
Limited warranty on all other components of 1 year
Limited warranty on Lennox® CORE Control System of 3 years
See Limited Warranty Certificate included with unit for details



Lennox National Accounts Project Submittal

Corner Weights (lb)						Center of Gravity (in.)					
AA		BB		CC		DD		EE		FF	
Base	Max	Base	Max	Base	Max	Base	Max	Base	Max	Base	Max
306	349	275	305	295	326	334	382	46.50	45.50	24.50	25.50

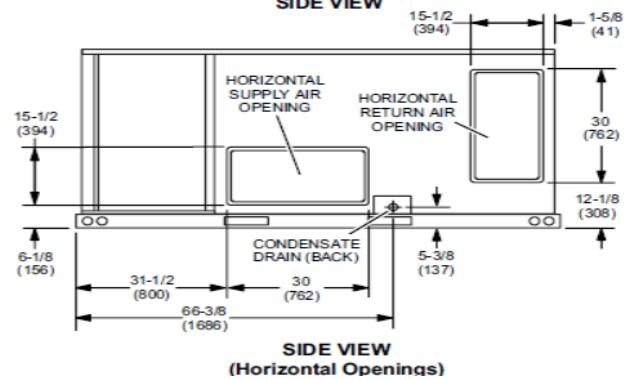
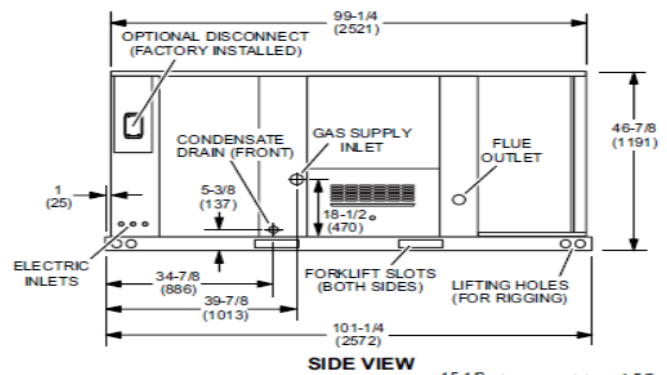
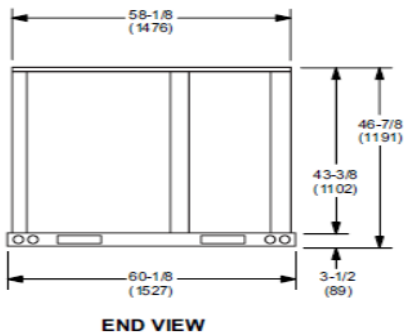
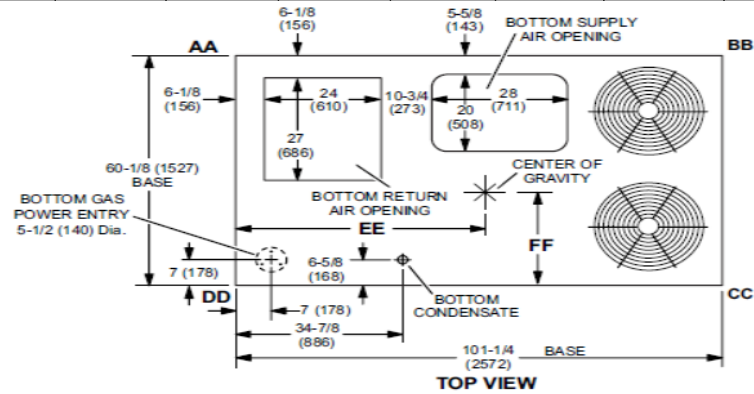

OUTDOOR AIR HOOD DETAIL

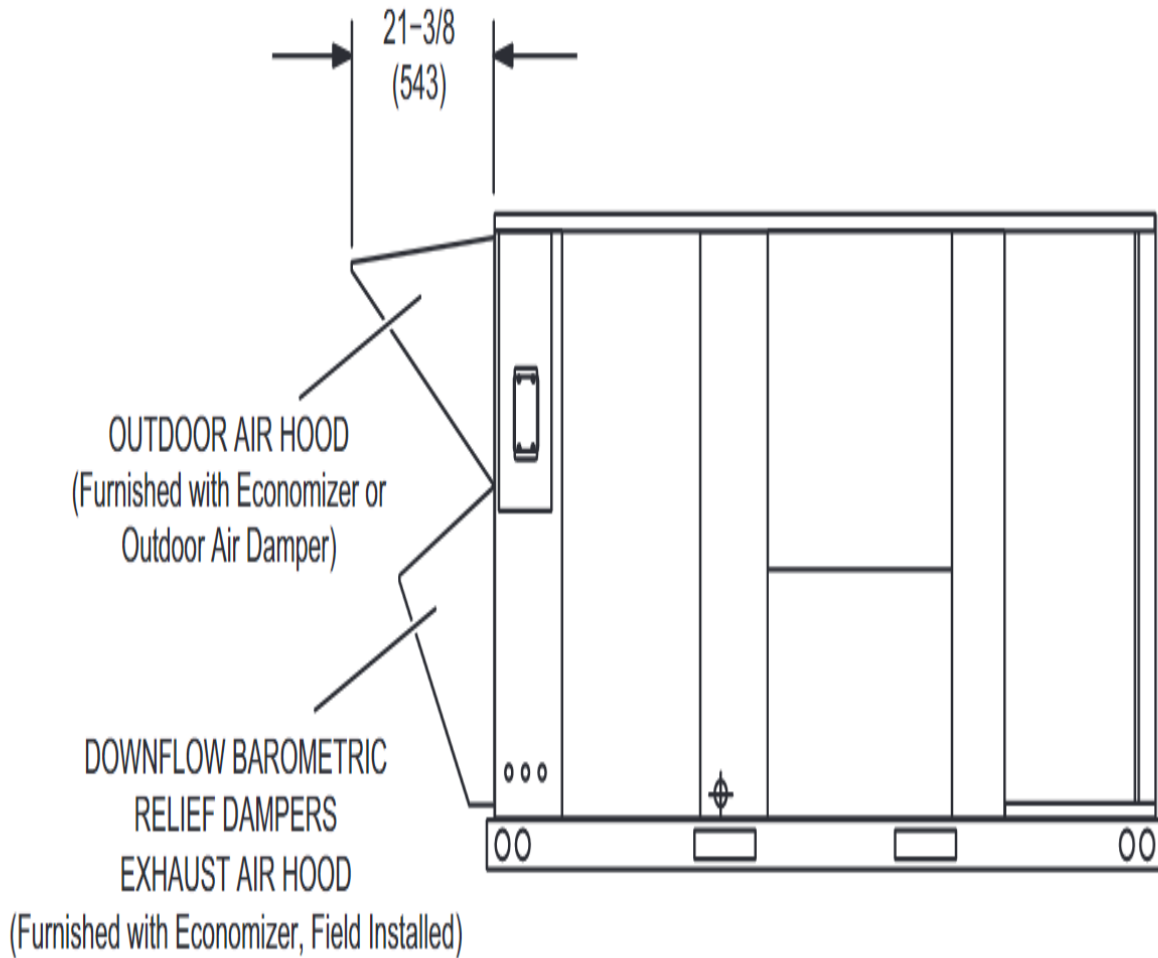



Lennox National Accounts Project Submittal

UNIT CLEARANCES

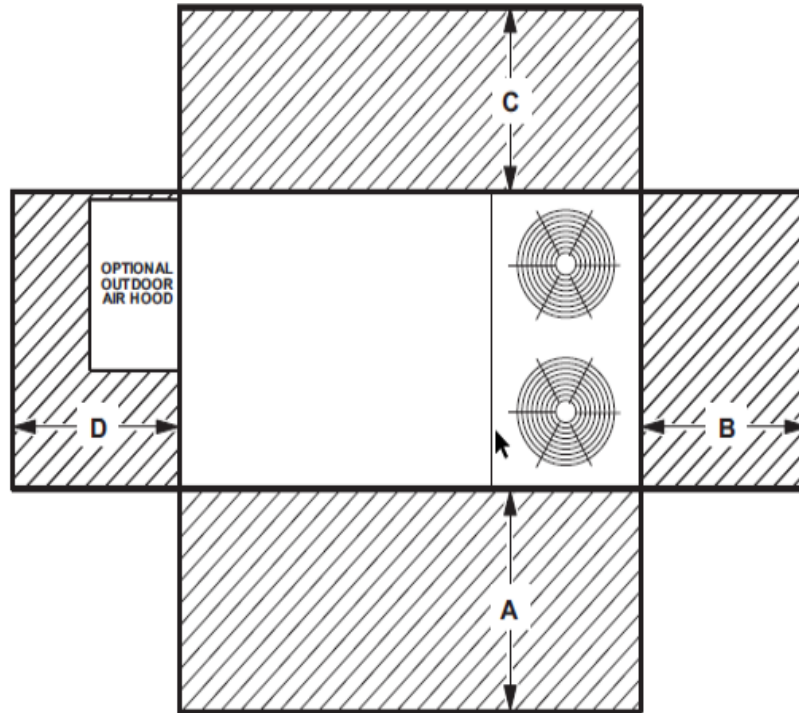

¹ Unit Clearance	A		B		C		D		Top Clearance
	in.	mm	in.	mm	in.	mm	in.	mm	
Service Clearance	60	1524	36	914	36	934	60	1524	Unobstructed
Clearance to Combustibles	36	914	1	25	1	25	1	25	
Minimum Operation Clearance	36	914	36	914	36	914	36	914	

NOTE - Entire perimeter of unit base requires support when elevated above the mounting surface.

¹ Service Clearance - Required for removal of serviceable parts.

Clearance to Combustibles - Required clearance to combustible material.

Minimum Operation Clearance - Required clearance for proper unit operation.



Lennox National Accounts Project Submittal

Tag: RTU 5
Model: LGT120H5E - LGT120H5E-G 10T

UNIT OVERVIEW

Voltage	IEER EER	MCA/MOCP (amp)	Gross Cooling Ttl/Sens (MBH)	Net Cooling Ttl/Sens (MBH)	Supply Air Flow (cfm)	ESP/TSP (in.WC)	EAT DB/WB (°F)	LAT DB/WB (°F)
460V 3Ph 60Hz	16.1 12.1	25 / 30	125.7 / 91.8	119.2 / 85.2	4,000	0.50 / 1.09	80.0 / 67.0	57.7 / 56.5

COOLING

Cooling Performance		Temperatures (DB/WB °F)	
Gross Cooling (Ttl/Sens)	125.7 / 91.8 MBH	Ambient	95.0
Net Cooling (Ttl/Sens)	119.2 / 85.2 MBH	Entering	80.0
Coil Moisture Removal	31.99 lb/hr	Total Leaving – (Coil)	57.7
System Moisture Removal	31.99 lb/hr	Total Leaving – (Unit)	59.3
			57.1

ARI Performance		Compressors		Refrigerant		Condensate Drain	
ARI Cooling	121.0 / 118.0 MBH	Cooling Stages	3.0	Type	R-454B	Qty	1
ARI Power	9,900 W	Compressor Qty	2	Charge	11 LBS. 12 OZ.	Size	1 in.
		Compressor RLA	14 amp			Pipe Thread	npt

HEATING

Heating Performance		Temperatures (DB/WB °F)		Specifications	
Output (High/Low)	194.0 / 126.4 MBH	Total Leaving	44.9	Heat Stages	2
Input (High/Low)	240.0 / 156.0 MBH			Thermal Efficiency	81.0%
Gas Heat Rise	44.9 °F			Gas Line Size	0.75 in.
				Gas Pressure	7 in.WC

VENTILATION

Air Flow (cfm)		Supply Fan		Air Resistance (in.WC)	
Supply	4,000	Nominal Power	3.75 hp	Total	1.09
		Required Power	2.05 hp	Ext Supply	0.50
		Drive Type	ECM Direct Drive		
		Required Watts	1,526 W		
		Exh Fan Nom HP	0.33 hp		

AIR RESISTANCE - OPTIONS/ACCESSORIES (in.WC)

Wet Coil	Humiditrol	Heat	Economizer	Filters	Diffuser	Exhaust	ERW
0.14		0.22	0.19	0.04			

ELECTRICAL

Voltage	460V 3Ph / 60Hz	Compressor RLA	14.0 amp
MCA	25 amp	Condenser FLA	3.0 amp
MOCP	30 amp	Supply Fan FLA	4.3 amp
Oper Range-Nom Volt	+/- 10%	Exh Fan Mtr FLACooling FLA	1.3 amp/22.6 amp
		Total	

ADDITIONAL DATA

Cabinet	101.25 in. x 60.12 in. x 46.88 in.	Total Weight	1,249 lb
Downflow Supply	20.0 in. x 28.0 in.	Base Unit Net Weight	1,100 lb
Downflow Return	24.0 in. x 27.0 in.	OAS/Econ Weight	86 lb
Filters	(4) 20.0 in. x 25.0 in. x 2.0 in.	Exhaust Weight	31 lb
Sound Rating	89 dBA	Gas Heat Weight	32 lb



Lennox National Accounts Project Submittal

Tag: RTU 5

Factory Installed Options

High Performance Economizer Factory Installed
 Single Enthalpy High Performance Economizer
 Direct Drive
 Unit Orientation Downflow
 Supply Fan: Multi-Speed ECM Direct Drive
 440V/460V/480V 3Phase
 80Amp Non-Fused Disconnect Factory Installed
 Built-in BACnet IP and MS/TP (standard)
 Refrigerant R-454B
 Supply Motor - 3.75 Hp - DirectPlus w/MSAV
 Std Static Power Exhaust Fan Factory Installed
 240K A.S. (Dual Stage)
 Hinged Access Doors Factory Installed
 15A GFCI Factory Installed/Field Wired
 Supply Air Smoke Detector Factory Installed
 Return Air Smoke Detector Factory Installed
 Environ Condenser Coil System Factory Installed
 Drain Pan Overflow Switch Factory Installed
 2" MERV8 - Filter Factory installed

Field Installed Accessories

Catalog Number	Qty	Description
23V86	1	CO2 Sensors - Wall-mount, white plastic cover, no display Field Installed
Y3027	1	BE RTS2-AOS Multi Signal Accessory

Product Features

Cabinet

Hinged Access Panels
 Durable Outdoor Enamel Paint Finish
 Totally Enclosed Outdoor Fan Motor
 PVC Coated Fan Guard
 Corrosion-Resistant Removable, Reversible Drain Pan
 Isolated Compressor Compartment

Cooling System

Scroll Compressor
 Expansion Valves
 High Capacity Driers
 Crankcase Heater
 System can operate from 0°F to 125°F without any additional controls
 Pre-charged Refrigeration System
 Timed Off Control
 Internal Pressure Relief Valve

Heating System

Redundant Automatic Gas Valve with Manual Shut-off
 Electronic Flame Sensor
 Direct Spark Ignition
 Inshot Burners
 AGA-CGA Certified
 If configured for room sensor control, additional staging may be possible. Refer to performance tables within the EHB

Control System

Fan and Limit Controls
 Overload Protection
 Microprocessor Controls – Lennox® CORE Control System
 Auto reset high & low pressure switch with strike 3 lockout feature in Lennox® CORE Control System
 Built-in BACnet IP & MS/TP
 Phase/Voltage Detection
 Return Air Sensor Factory Installed
 Outdoor Air Sensor Factory Installed
 Factory Installed Discharge Air Sensor



Lennox National Accounts Project Submittal

Refrigerant Detection System (RDS) and mitigation response, per UL safety standard 60335-2-40

Compliance

Components are Bonded for Grounding

Factory Test Operated

All models are ASHRAE 90.1 energy efficiency compliant and meet or exceed requirements of Section 6.8

All models meet DOE 2023 energy efficiency standards

All models are compliant with and listed to UL standard 60335-2-40

Model meets California Code of Regulations, Title 24 and ASHRAE 90.1-2016 Section 6.4.3.10 requirements for staged airflow

Model meets HCAI (formerly OSHPD) OSP and Special Seismic Certification (Number: OSP-0596) and meet 2018 International Building Code (IBC), 2019

California Building Code (CBC) ASCE 7, and ICC-ES AC156

ISO 9001 Registered Manufacturing Quality System

Only refrigerants in compliance with New York State regulations can be used in the state of New York

Warranty

Limited warranty on aluminized heat exchanger of 10 years

Limited warranty on compressor of 5 years

Limited warranty on Environ Coil System of 3 years

Limited warranty on High Performance Economizer of 5 years

Limited warranty on all other components of 1 year

Limited warranty on Lennox® CORE Control System of 3 years

See Limited Warranty Certificate included with unit for details



Lennox National Accounts Project Submittal

Corner Weights (lb)						Center of Gravity (in.)					
AA		BB		CC		DD		EE		FF	
Base	Max	Base	Max	Base	Max	Base	Max	Base	Max	Base	Max
306	349	275	305	295	326	334	382	46.50	45.50	24.50	25.50

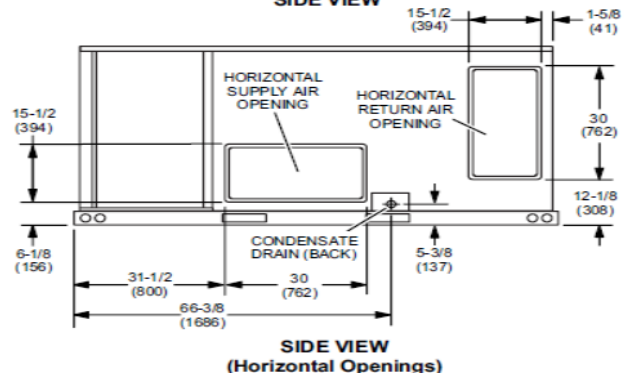
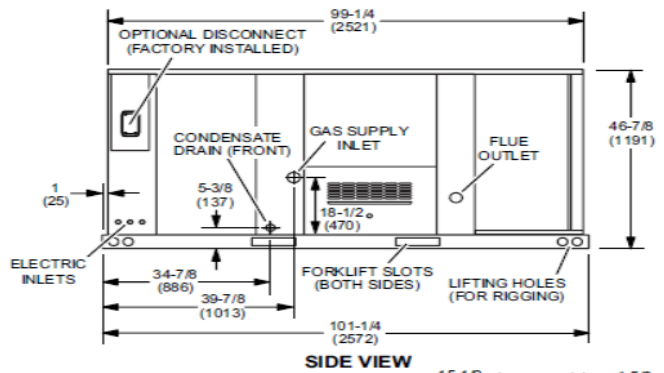
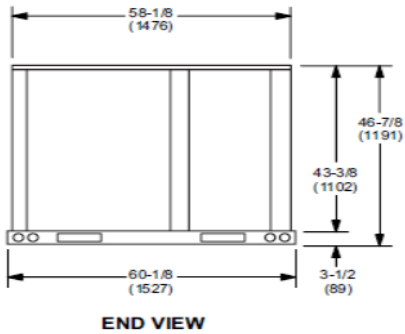
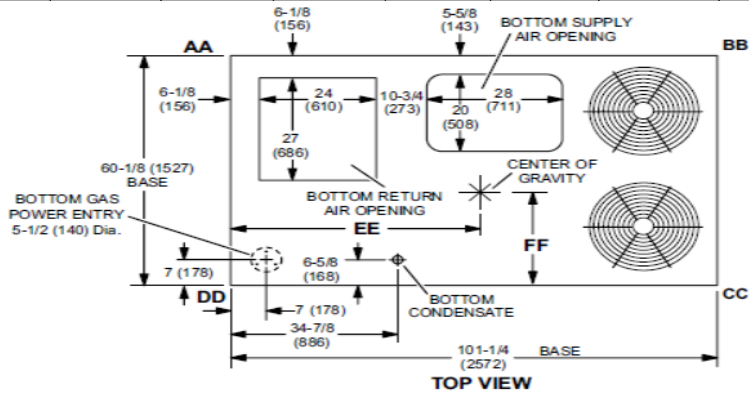

OUTDOOR AIR HOOD DETAIL

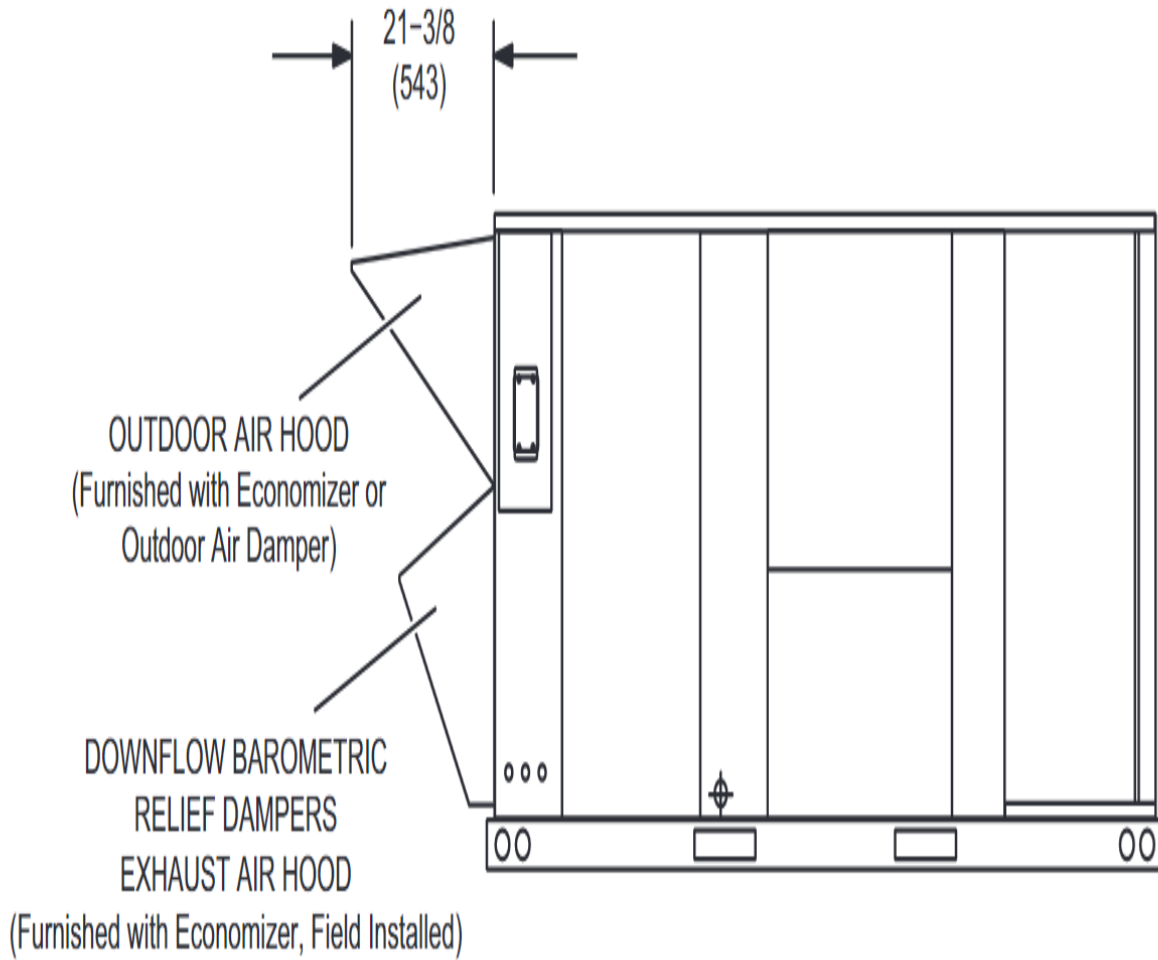



Lennox National Accounts Project Submittal

UNIT CLEARANCES

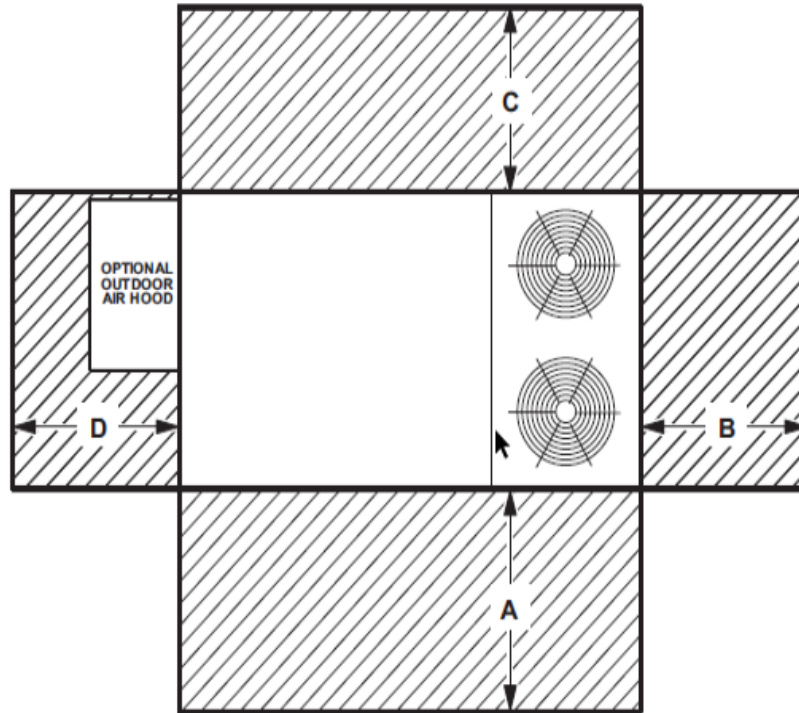

¹ Unit Clearance	A		B		C		D		Top Clearance
	in.	mm	in.	mm	in.	mm	in.	mm	
Service Clearance	60	1524	36	914	36	934	60	1524	Unobstructed
Clearance to Combustibles	36	914	1	25	1	25	1	25	
Minimum Operation Clearance	36	914	36	914	36	914	36	914	

NOTE - Entire perimeter of unit base requires support when elevated above the mounting surface.

¹ Service Clearance - Required for removal of serviceable parts.

Clearance to Combustibles - Required clearance to combustible material.

Minimum Operation Clearance - Required clearance for proper unit operation.



Lennox National Accounts Project Submittal

Tag: RTU 6
 Model: LGT036H5E - LGT036H5E-G 3T

UNIT OVERVIEW

Voltage	SEER2 EER2	MCA/MOCP (amp)	Gross Cooling Ttl/Sens (MBH)	Net Cooling Ttl/Sens (MBH)	Supply Air Flow (cfm)	ESP/TSP (in.WC)	EAT DB/WB (°F)	LAT DB/WB (°F)
460V 3Ph 60Hz	17.5 13.5	10 / 15	37.8 / 27.6	36.5 / 26.3	1,200	0.50 / 0.62	80.0 / 67.0	57.6 / 56.5

COOLING

Cooling Performance		Temperatures (DB/WB °F)	
Gross Cooling (Ttl/Sens)	37.8 / 27.6 MBH	Ambient	95.0
Net Cooling (Ttl/Sens)	36.5 / 26.3 MBH	Entering	80.0 67.0
Coil Moisture Removal	9.62 lb/hr	Total Leaving – (Coil)	57.6 56.5
System Moisture Removal	9.62 lb/hr	Total Leaving – (Unit)	58.7 56.9

ARI Performance		Compressors		Refrigerant		Condensate Drain	
ARI Cooling	36.6 / 36.0 MBH	Cooling Stages	2.0	Type	R-454B	Qty	1
ARI Power	2,700 W	Compressor Qty	1	Charge	4 LBS. 14 OZ.	Size	1 in.
		Compressor RLA	4.6 amp			Pipe Thread	npt

HEATING

Heating Performance		Temperatures (DB/WB °F)		Specifications	
Output (High/Low)	87.0 / 66.0 MBH	Total Leaving	66.4	Heat Stages	2
Input (High/Low)	108.0 / 81.0 MBH			Thermal Efficiency NOX	81.0%
Gas Heat Rise	66.4 °F			Gas Line Size	0.5 in.
				Gas Pressure	7 in.WC

VENTILATION

Air Flow (cfm)		Supply Fan		Air Resistance (in.WC)	
Supply	1,200	Nominal Power	0.50 hp	Total	0.62
		Required Power	0.41 hp	Ext Supply	0.50
		Drive Type	ECM Direct Drive		
		Required Watts	308 W		
		Motor Torque	66		
		Exh Fan Nom HP	0.33 hp		

AIR RESISTANCE - OPTIONS/ACCESSORIES (in.WC)

Wet Coil	Humiditrol	Heat	Economizer	Filters	Diffuser	Exhaust	ERW
0.03		0.02	0.04	0.03			

ELECTRICAL

Voltage	460V 3Ph / 60Hz	Compressor RLA	4.6 amp
MCA	10 amp	Condenser FLA	1.4 amp
MOCP	15 amp	Supply Fan FLA	2.2 amp
Oper Range-Nom Volt	+/- 10%	Exh Fan Mtr FLACooling FLA	1.3 amp9.5 amp
		Total	

ADDITIONAL DATA

Cabinet	85.25 in. x 47.00 in. x 46.88 in.	Total Weight	722 lb
Downflow Supply	20.0 in. x 18.0 in.	Base Unit Net Weight	630 lb
Downflow Return	29.0 in. x 11.0 in.	OAS/Econ Weight	84 lb
Filters	(4) 20.0 in. x 20.0 in. x 2.0 in.	Gas Heat Weight	8 lb
Sound Rating	75 dBA		



Lennox National Accounts Project Submittal

Tag: RTU 6

Factory Installed Options

- High Performance Economizer Factory Installed
- Single Enthalpy High Performance Economizer
- Direct Drive
- Unit Orientation Downflow
- Supply Fan: Multi-Speed ECM Direct Drive
- 440V/460V/480V 3Phase
- 80Amp Non-Fused Disconnect Factory Installed
- Built-in BACnet IP and MS/TP (standard)
- Refrigerant R-454B
- Supply Motor - 0.50 Hp ECM - w/ MSAV
- Barometric Relief Damper Factory Installed
- 108K A.S. (Dual Stage)
- Low Nox Factory Installed
- Hinged Access Doors Factory Installed
- 15A GFCI Factory Installed/Field Wired
- Phase/Voltage Detection Factory Installed
- Supply Air Smoke Detector Factory Installed
- Return Air Smoke Detector Factory Installed
- Environ Evaporator and Condenser Coil System Factory Installed
- Drain Pan Overflow Switch Factory Installed
- 2" MERV8 - Filter Factory installed

Field Installed Accessories

Catalog Number	Qty	Description
Y3027	1	BE RTS2-AOS Multi Signal Accessory

Product Features

Cabinet

- Hinged Access Panels
- Durable Outdoor Enamel Paint Finish
- Totally Enclosed Outdoor Fan Motor
- PVC Coated Fan Guard
- Corrosion-Resistant Removable, Reversible Drain Pan
- Isolated Compressor Compartment

Cooling System

- Scroll Compressor
- Expansion Valves
- High Capacity Driers
- Crankcase Heater
- System can operate from 0°F to 125°F without any additional controls
- Pre-charged Refrigeration System
- Timed Off Control
- Internal Pressure Relief Valve

Heating System

- Redundant Automatic Gas Valve with Manual Shut-off
- Electronic Flame Sensor
- Direct Spark Ignition
- Inshot Burners
- AGA-CGA Certified
- If configured for room sensor control, additional staging may be possible. Refer to performance tables within the EHB

Control System

- Fan and Limit Controls
- Overload Protection
- Microprocessor Controls – Lennox® CORE Control System
- Auto reset high & low pressure switch with strike 3 lockout feature in Lennox® CORE Control System
- Built-in BACnet IP & MS/TP
- Return Air Sensor Factory Installed
- Outdoor Air Sensor Factory Installed
- Factory Installed Discharge Air Sensor



Lennox National Accounts Project Submittal

Refrigerant Detection System (RDS) and mitigation response, per UL safety standard 60335-2-40

Compliance

Components are Bonded for Grounding

Factory Test Operated

All models are ASHRAE 90.1 energy efficiency compliant and meet or exceed requirements of Section 6.8

All models meet DOE 2023 energy efficiency standards

All models are compliant with and listed to UL standard 60335-2-40

Model meets California Code of Regulations, Title 24 and ASHRAE 90.1-2016 Section 6.4.3.10 requirements for staged airflow

Model meets HCAI (formerly OSHPD) OSP and Special Seismic Certification (Number: OSP-0596) and meet 2018 International Building Code (IBC), 2019

California Building Code (CBC) ASCE 7, and ICC-ES AC156

ISO 9001 Registered Manufacturing Quality System

Only refrigerants in compliance with New York State regulations can be used in the state of New York

Warranty

Limited warranty on aluminized heat exchanger of 10 years

Limited warranty on compressor of 5 years

Limited warranty on Environ Coil System of 3 years

Limited warranty on High Performance Economizer of 5 years

Limited warranty on all other components of 1 year

Limited warranty on Lennox® CORE Control System of 3 years

See Limited Warranty Certificate included with unit for details



Lennox National Accounts Project Submittal

Corner Weights (lb)						Center of Gravity (in.)					
AA		BB		CC		DD		EE		FF	
Base	Max	Base	Max	Base	Max	Base	Max	Base	Max	Base	Max
131	168	161	207	220	283	179	230	38.25	39.75	19.88	19.88

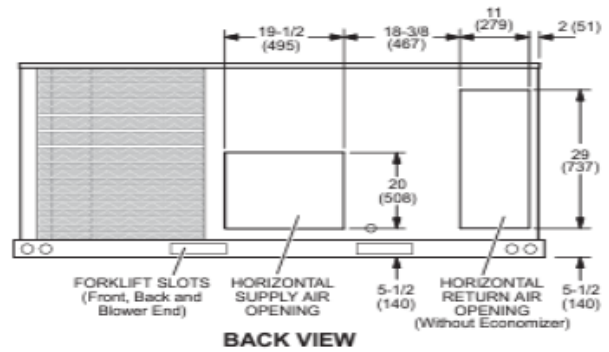
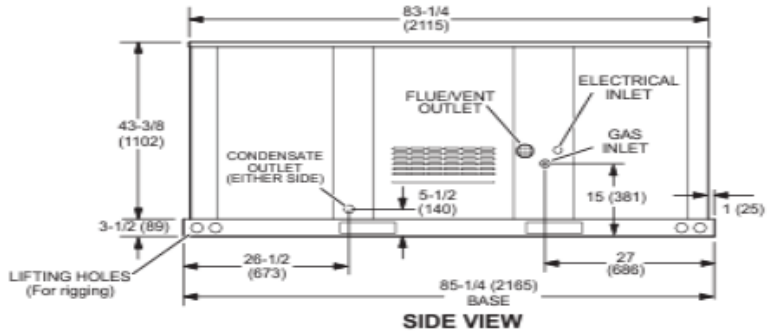
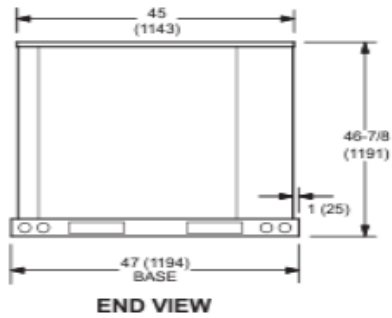
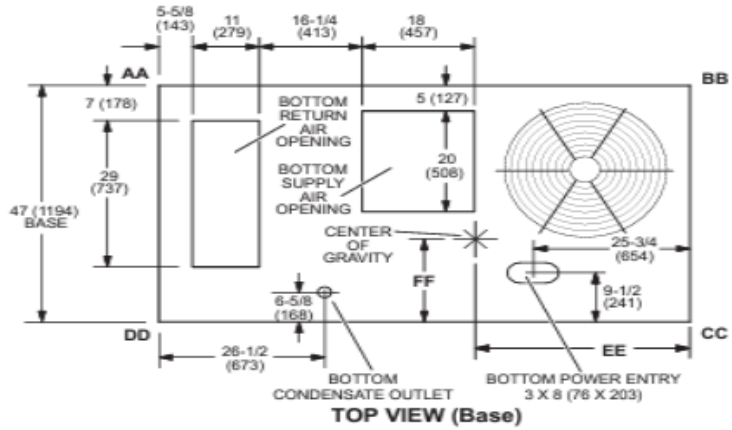



Lennox National Accounts Project Submittal

UNIT CLEARANCES

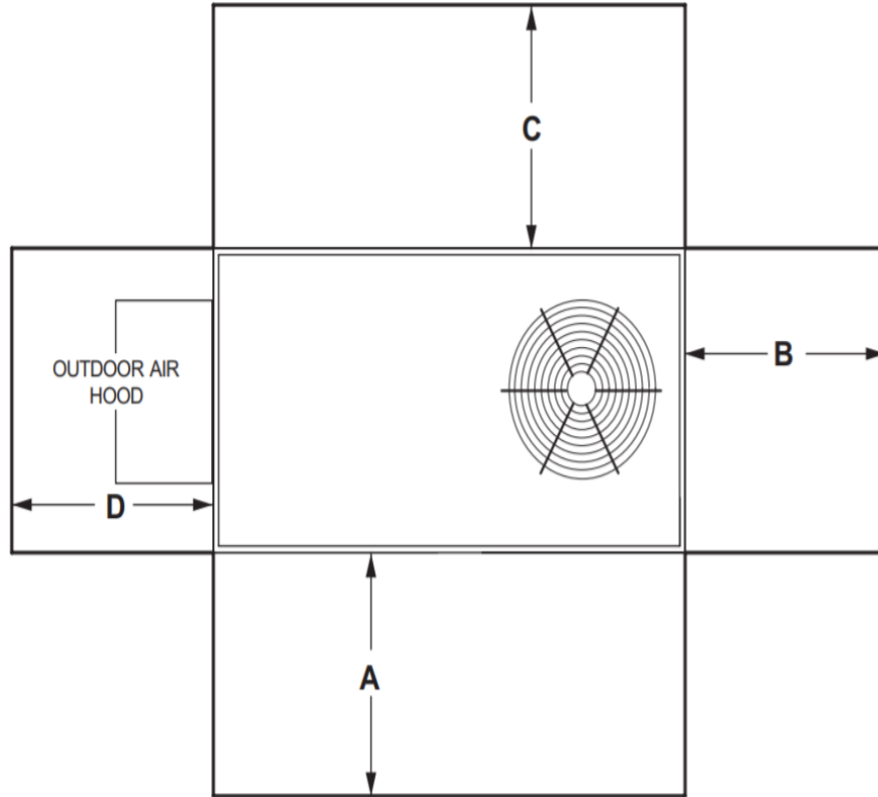

¹ Unit Clearance	A		B		C		D		Top Clearance
	in.	mm	in.	mm	in.	mm	in.	mm	
Service Clearance	48	1219	36	914	36	934	36	914	Unobstructed
Clearance to Combustibles	36	914	1	25	1	25	1	25	
Minimum Operation Clearance	36	914	36	914	36	914	36	914	

NOTE - Entire perimeter of unit base requires support when elevated above the mounting surface.

¹ **Service Clearance** - Required for removal of serviceable parts.

Clearance to Combustibles - Required clearance to combustible material.

Minimum Operation Clearance - Required clearance for proper unit operation.



Lennox National Accounts Project Submittal

Tag: RTU 7,8
 Model: LGT060H5E - LGT060H5E-G 5T

UNIT OVERVIEW

Voltage	SEER2 EER2	MCA/MOCP (amp)	Gross Cooling Ttl/Sens (MBH)	Net Cooling Ttl/Sens (MBH)	Supply Air Flow (cfm)	ESP/TSP (in.WC)	EAT DB/WB (°F)	LAT DB/WB (°F)
460V 3Ph 60Hz	16.4 12.5	14 / 15	65.6 / 49.2	62.0 / 45.6	2,000	0.50 / 0.74	80.0 / 67.0	56.0 / 56.0

COOLING

Cooling Performance		Temperatures (DB/WB °F)	
Gross Cooling (Ttl/Sens)	65.6 / 49.2 MBH	Ambient	95.0
Net Cooling (Ttl/Sens)	62.0 / 45.6 MBH	Entering	80.0 67.0
Coil Moisture Removal	15.46 lb/hr	Total Leaving – (Coil)	56.0 56.0
System Moisture Removal	15.46 lb/hr	Total Leaving – (Unit)	57.8 56.7

ARI Performance		Compressors		Refrigerant		Condensate Drain	
ARI Cooling	61.6 / 60.0 MBH	Cooling Stages	2.0	Type	R-454B	Qty	1
ARI Power	4,600 W	Compressor Qty	1	Charge	4 LBS. 14 OZ.	Size	1 in.
		Compressor RLA	6.5 amp			Pipe Thread	npt

HEATING

Heating Performance		Temperatures (DB/WB °F)		Specifications	
Output (High/Low)	87.0 / 66.0 MBH	Total Leaving	39.8	Heat Stages	2
Input (High/Low)	108.0 / 81.0 MBH			Thermal Efficiency NOX	81.0%
Gas Heat Rise	39.8 °F			Gas Line Size	0.5 in.
				Gas Pressure	7 in.WC

VENTILATION

Air Flow (cfm)		Supply Fan		Air Resistance (in.WC)	
Supply	2,000	Nominal Power	1.00 hp	Total	0.74
		Required Power	1.14 hp	Ext Supply	0.50
		Drive Type	ECM Direct Drive		
		Required Watts	849 W		
		Motor Torque	82		
		Exh Fan Nom HP	0.33 hp		

AIR RESISTANCE - OPTIONS/ACCESSORIES (in.WC)

Wet Coil	Humiditrol	Heat	Economizer	Filters	Diffuser	Exhaust	ERW
0.10		0.04	0.05	0.05			

ELECTRICAL

Voltage	460V 3Ph / 60Hz	Compressor RLA	6.5 amp
MCA	14 amp	Condenser FLA	1.4 amp
MOCP	15 amp	Supply Fan FLA	3.7 amp
Oper Range-Nom Volt	+/- 10%	Cooling FLA Total	11.6 amp

ADDITIONAL DATA

Cabinet	85.25 in. x 47.00 in. x 46.88 in.	Total Weight	722 lb
Downflow Supply	20.0 in. x 18.0 in.	Base Unit Net Weight	630 lb
Downflow Return	29.0 in. x 11.0 in.	OAS/Econ Weight	84 lb
Filters	(4) 20.0 in. x 20.0 in. x 2.0 in.	Gas Heat Weight	8 lb
Sound Rating	82 dBA		



Lennox National Accounts Project Submittal

Tag: RTU 7,8

Factory Installed Options

- High Performance Economizer Factory Installed
- Single Enthalpy High Performance Economizer
- Direct Drive
- Unit Orientation Downflow
- Supply Fan: Multi-Speed ECM Direct Drive
- 440V/460V/480V 3Phase
- 80Amp Non-Fused Disconnect Factory Installed
- Built-in BACnet IP and MS/TP (standard)
- Refrigerant R-454B
- Supply Motor - 1.0 Hp ECM - Multi-Speed Direct Drive
- Barometric Relief Damper Factory Installed
- 108K A.S. (Dual Stage)
- Low Nox Factory Installed
- Hinged Access Doors Factory Installed
- 15A GFCI Factory Installed/Field Wired
- Phase/Voltage Detection Factory Installed
- Supply Air Smoke Detector Factory Installed
- Return Air Smoke Detector Factory Installed
- Environ Evaporator and Condenser Coil System Factory Installed
- Drain Pan Overflow Switch Factory Installed
- 2" MERV8 - Filter Factory installed

Field Installed Accessories

Catalog Number	Qty	Description
Y3027	2	BE RTS2-AOS Multi Signal Accessory

Product Features

Cabinet

- Hinged Access Panels
- Durable Outdoor Enamel Paint Finish
- Totally Enclosed Outdoor Fan Motor
- PVC Coated Fan Guard
- Corrosion-Resistant Removable, Reversible Drain Pan
- Isolated Compressor Compartment

Cooling System

- Scroll Compressor
- Expansion Valves
- High Capacity Driers
- Crankcase Heater
- System can operate from 0°F to 125°F without any additional controls
- Pre-charged Refrigeration System
- Timed Off Control
- Internal Pressure Relief Valve

Heating System

- Redundant Automatic Gas Valve with Manual Shut-off
- Electronic Flame Sensor
- Direct Spark Ignition
- Inshot Burners
- AGA-CGA Certified
- If configured for room sensor control, additional staging may be possible. Refer to performance tables within the EHB

Control System

- Fan and Limit Controls
- Overload Protection
- Microprocessor Controls – Lennox® CORE Control System
- Auto reset high & low pressure switch with strike 3 lockout feature in Lennox® CORE Control System
- Built-in BACnet IP & MS/TP
- Return Air Sensor Factory Installed
- Outdoor Air Sensor Factory Installed
- Factory Installed Discharge Air Sensor



Lennox National Accounts Project Submittal

Refrigerant Detection System (RDS) and mitigation response, per UL safety standard 60335-2-40

Compliance

Components are Bonded for Grounding

Factory Test Operated

All models are ASHRAE 90.1 energy efficiency compliant and meet or exceed requirements of Section 6.8

All models meet DOE 2023 energy efficiency standards

All models are compliant with and listed to UL standard 60335-2-40

Model meets California Code of Regulations, Title 24 and ASHRAE 90.1-2016 Section 6.4.3.10 requirements for staged airflow

Model meets HCAI (formerly OSHPD) OSP and Special Seismic Certification (Number: OSP-0596) and meet 2018 International Building Code (IBC), 2019

California Building Code (CBC) ASCE 7, and ICC-ES AC156

ISO 9001 Registered Manufacturing Quality System

Only refrigerants in compliance with New York State regulations can be used in the state of New York

Warranty

Limited warranty on aluminized heat exchanger of 10 years

Limited warranty on compressor of 5 years

Limited warranty on Environ Coil System of 3 years

Limited warranty on High Performance Economizer of 5 years

Limited warranty on all other components of 1 year

Limited warranty on Lennox® CORE Control System of 3 years

See Limited Warranty Certificate included with unit for details



Lennox National Accounts Project Submittal

Corner Weights (lb)						Center of Gravity (in.)					
AA		BB		CC		DD		EE		FF	
Base	Max	Base	Max	Base	Max	Base	Max	Base	Max	Base	Max
131	169	161	208	220	284	179	231	38.25	39.75	19.88	19.88

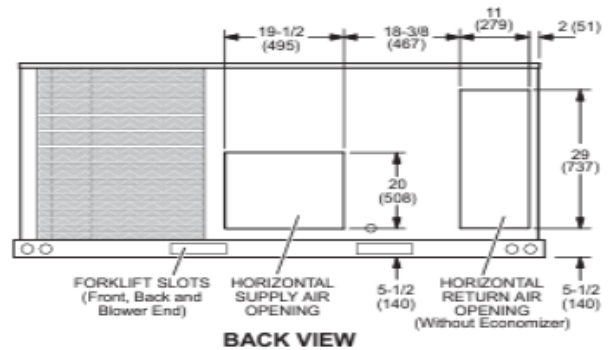
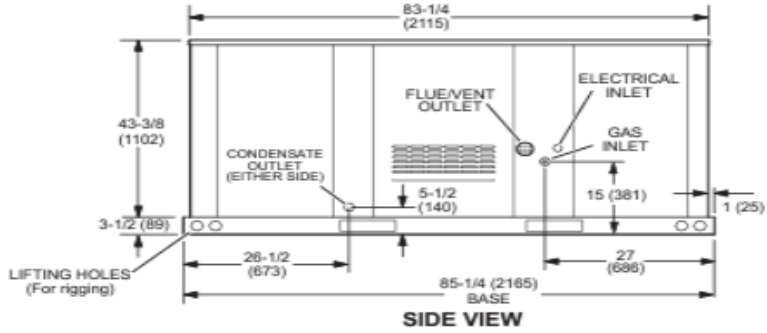
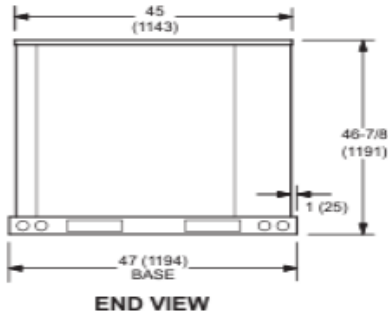
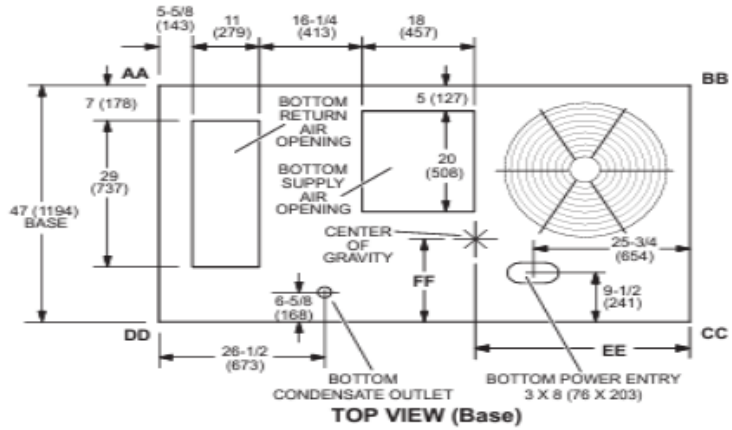



Lennox National Accounts Project Submittal

UNIT CLEARANCES

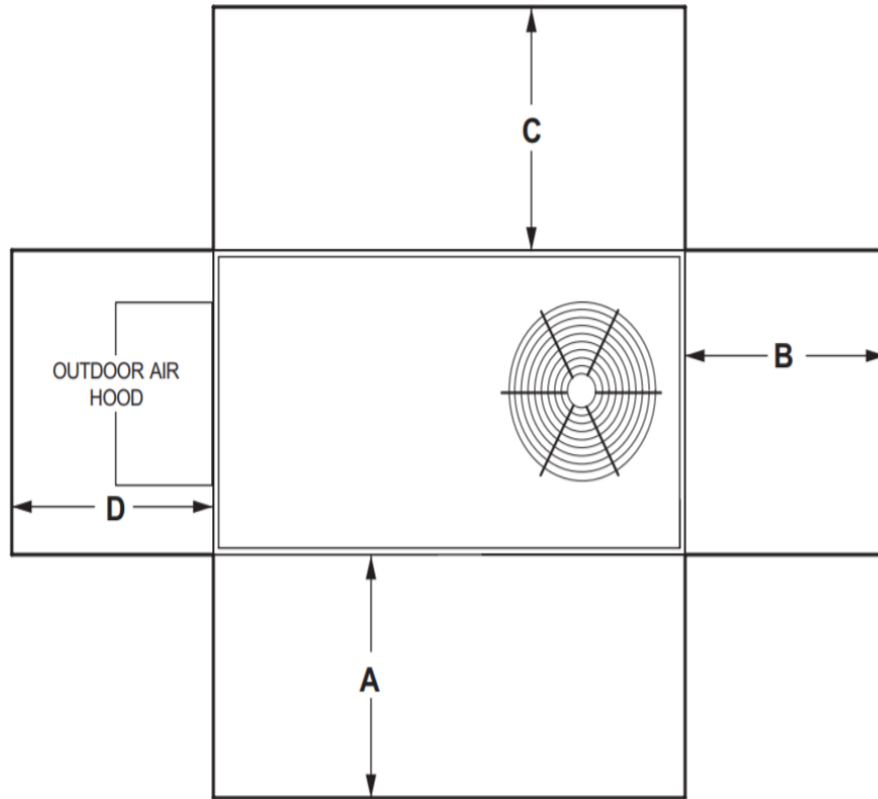

¹ Unit Clearance	A		B		C		D		Top Clearance
	in.	mm	in.	mm	in.	mm	in.	mm	
Service Clearance	48	1219	36	914	36	934	36	914	Unobstructed
Clearance to Combustibles	36	914	1	25	1	25	1	25	
Minimum Operation Clearance	36	914	36	914	36	914	36	914	

NOTE - Entire perimeter of unit base requires support when elevated above the mounting surface.

¹ **Service Clearance** - Required for removal of serviceable parts.

Clearance to Combustibles - Required clearance to combustible material.

Minimum Operation Clearance - Required clearance for proper unit operation.



Lennox National Accounts Project Submittal

Tag: Miscellaneous Items

Miscellaneous Items

Tag	Catalog Number	Qty	Description
Curb Adapter RTU 6,7,8			
	COMSD	1	Curb Adapter Curbs Plus