

Report By:

National TAB  
1329 E. KEMPER ROAD  
SUITE 4210  
CINCINNATI, OH 45246



**Report: TAB REPORT**  
**Function: Test, Adjust, & Balance**  
**Date: 03/15/2024**

# PROJECT

## 03-11-24 WAWA #5801 - FAIRHOPE, AL

18968 GREENO RD

FAIRHOPE, AL 36532

### Client

Wawa  
260 West Baltimore Pike  
Wawa, PA 19063

# National TAB

Project: 03-11-24 WAWA #5801 - FAIRHOPE, AL

## Table Of Contents

<b>Section</b>	<b>Page #</b>
Summary	3
Issue Data	4
Checklist Data	8
AHU/RTU	23
FAN - Exhaust	29
GRD Layout	32
Balance Schedule	33

## Project Summary

The summary below provides a quick understanding of our scope of work and general testing procedures. Enclosed in the report is further detail about your building performance including recommendations, asset data, and pictures. Our focus is to work with the trades to remedy any issues or deficiencies during the actual field balancing and not after the balancing has occurred to achieve a positive environment and outcome. The level of success is determined by the availability of the trades, possible parts needed, or time constraints.

### RTU's (Roof Top Units) w/ Diffusers

Each of the RTU's were measured at their terminal devices or via traverse to establish a total flow for that unit. Each RTU was adjusted to within tolerance of the engineer's design flow. Each outlet was then adjusted to within tolerance of the design flow. Outside air was measured by reading the intake air opening with a velocity grid and multiplying by the free area. The outside air damper was adjusted until the airflow was within the design requirements. Any equipment that fell outside of that tolerance is noted throughout the report.

### General Exhaust Fans w/ Grilles

The general exhaust fans were measured by reading each air device with a flow hood. The total airflow for each fan is equivalent to the sum of these readings. Fan speed was then adjusted so that the airflow was within tolerance of design. Each terminal device was balanced to within tolerance of the design volume using the installed volume dampers. Any equipment that fell outside of this tolerance is noted throughout the report.

### Ceiling Exhaust Fans

The ceiling exhaust fans were measured using a flow hood. If speed adjustment was provided, the fan speed was adjusted to within design tolerance. Any equipment that fell outside of this tolerance is noted throughout the report.

### Final Building Tests

After completing the test and balance the final building pressure was measured. It was confirmed that the building pressure fell within acceptable tolerances and that the pressure measurement coincides with the actual and design net airflow. Any deviations from these standards are noted throughout the report.

## Issue List

- Lennox sensor wiring
- Return grille R1 on RTU-2 is low on flow
- RTU-1 and 3 heating temperatures



03-11-24 WAWA #5801 - FAIRHOPE, AL

**Project Issue Information**

**Issue Name :** Lennox sensor wiring  
**Description :** Lennox manual shows 3 separate shielded twisted pairs to be ran for the temp/humidity sensors. However, all 6 conductors are run in a single non-shielded cable. Link to manual: [https://www.allied-commercial.com/AlliedCommercial/landing/e-series/product-literature/accessories/E-Series\\_Temperature\\_Humidity\\_Combos\\_Kit.pdf](https://www.allied-commercial.com/AlliedCommercial/landing/e-series/product-literature/accessories/E-Series_Temperature_Humidity_Combos_Kit.pdf)  
**Created By :** National TAB      **Assigned To :** National TAB - Will Turnbough  
**Status :** Open  
**Priority :** Medium      **Asset Tag :** RTU1  
**Originated Date :** 03/13/2024 - Will Turnbough - National TAB

Project Issue File Details



Image\_17\_  
03/13/2024

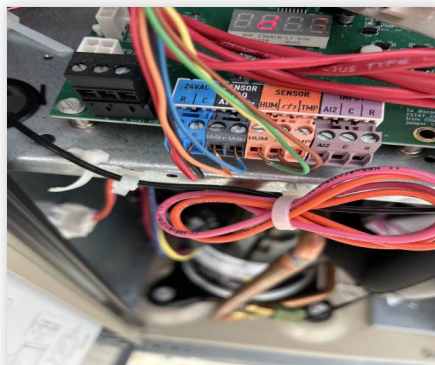

Image\_16\_  
03/13/2024

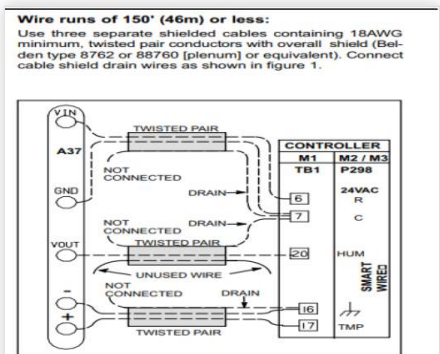

sensor\_wiring  
03/13/2024



**03-11-24 WAWA #5801 - FAIRHOPE, AL**

**Project Issue Information**

**Issue Name :** Return grille R1 on RTU-2 is low on flow  
**Description :** Restrictive ductwork preventing return R-1 from reaching design flow. Total supply and return flow is within tolerance. Recommend straightening ductwork to improve unit performance, but return trip not necessary to re-measure airflow

**Created By :** National TAB                      **Assigned To :** National TAB - Will Turnbough

**Status :** Open

**Priority :** Low                                      **Asset Tag :** RTU2

**Originated Date :** 03/13/2024 - Gabe Merk - National TAB

Project Issue File Details

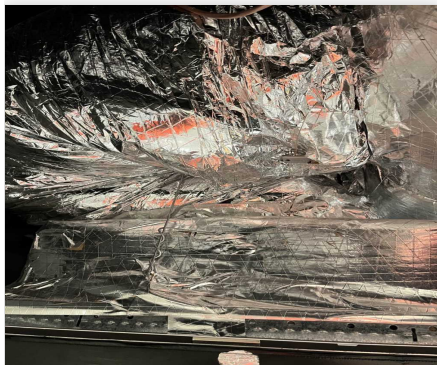

0A027780\_7B67\_4319\_AF..  
03/13/2024



**03-11-24 WAWA #5801 - FAIRHOPE, AL**

**Project Issue Information**

**Issue Name :** RTU-1 and 3 heating temperatures  
**Description :** RTU discharge temperatures during heating were measured to be 71 and 72 degrees, respectively. Verified similar readings on Lennox CORE. Recommend mechanical contractor investigate.  
**Created By :** National TAB                      **Assigned To :** National TAB - Will Turnbough  
**Status :** Open  
**Priority :** High                                      **Asset Tag :** RTU1  
**Originated Date :** 03/15/2024 - Will Turnbough - National TAB

## CheckList List

- TECH - 1 RTUS/AHUS
- TECH - 2 LENNOX SETUP PARAMETERS
- TECH - 3 SENSOR WIRING (LENNOX)
- TECH - 4 EF'S
- TECH - 5 CLOSEOUT CHECKS
- TECH - SITE PICTURES



### 03-11-24 WAWA #5801 - FAIRHOPE, AL

#### CheckList Information

**Name :** TECH - 1 RTUS/AHUS **Status :** Not Completed  
**Assigned Organization :** National TAB **Asset :**  
**Requesting Organization :** National TAB  
**Created Date :** 03/11/2024 - Brianna Biggs - National TAB

#### CheckList Item Details

##### RTU's/AHU's

All diffusers and grilles are installed and match design? Pass

**Comment:**

Clean filters installed? Pass

**Comment:**

Economizers are assembled and functional? Pass

**Comment:**

Motors are all operating below the FLA rating? Pass

**Comment:**

Are belts tight? N/A

**Comment:**

If direct drive unit is the speed controller working? Pass

**Comment:**

Is gas piping installed and valves turned on? N/A

**Comment:**

Condensate drains are installed?

Pass

**Comment:**

Unit free of noticeable noise and vibration

Pass

**Comment:**

Final outside air damper position is marked with permanent marker?

Pass

**Comment:**

No alarms present?

Pass

**Comment:**

Any noticeable duct leakage?

Pass

**Comment:**

Total supply and OA flows are balanced within +/-5% and supply & return diffusers within +/-10%?

Fail

**Comment:**

RTU2 R-1 restrictive ductwork preventing flow, RTU 3 returns all reading ~90% of design.

**IN TEST MODE, TEST THE FOLLOWING:**

Cooling mode is operational? Record EAT/LAT for each unit:

Pass

**Comment:**

Rtu1 70/52 Rtu2 71/54 Rtu 3 71/50

Heating mode is operational? Record EAT/LAT for each unit:

Pass

**Comment:**

Rtu 1 69/72 coil hot Rtu 2 n/a Rtu 3 68/71 coil hot

Dehumidification mode is operational? (Feel dehumidification coil with your hand. Is it hot?)  
Record EAT/LAT for each unit:

Pass

**Comment:**

Rtu 1 70/67 coil hot Rtu 2 n/a Rtu 3 69/66 coil hot

**TRAVERSE READINGS (AFTER DIFFUSER BALANCING COMPLETE)**

---

RTU-1 Supply / Return

---

**Comment:**

3643/2986

---

RTU-2 Supply / Return

---

**Comment:**

no traverse locations/2255

---

RTU-3 Supply / Return

---

**Comment:**

3062/no traverse locations

---



### 03-11-24 WAWA #5801 - FAIRHOPE, AL

#### CheckList Information

**Name :** TECH - 2 LENNOX SETUP PARAMETERS      **Status :** Not Completed  
**Assigned Organization :** National TAB      **Asset :**  
**Requesting Organization :** National TAB  
**Created Date :** 03/11/2024 - Brianna Biggs - National TAB

#### CheckList Item Details

##### UNIT ID CONFIGURATIONS

BACNET CONFIGURATION: GO TO SETTINGS>INSTALL>CONFIGURATION ID1 POSITION 5 SET TO "B".      Pass

**Comment:**

ONLY HAS N AND L OPTIONS. SET TO N PER WAWA'S REQUEST.

NETWORK CONFIGURATION: GO TO SETUP>NETWORK INTEGRATION > SET TO BACNET      Pass

**Comment:**

DID NOT ADJUST. LEFT TO DEFAULT PER WAWA 'S REQUEST.

CONTROL MODE: SET CONTROL MODE TO ROOM SENSOR: CO2, TEMP & HUMIDITY (PER UNIT, AS NEEDED).      Pass

**Comment:**

DID NOT ADJUST. LEFT TO DEFAULT PER WAWA 'S REQUEST.

##### INDIVIDUAL PARAMETER CONFIGURATIONS (MECHANICAL CONTRACTOR TO DEFINE / AS APPLICABLE):

PARAMETER 105 DEHUMID MODE: 7 NO CONDITIONS      Pass

**Comment:**

PARAMETER 106 DEHUMID SETPOINT: 50, THIS IS A CENTERED SET POINT (+/-)      Yes

**Comment:**

PARAMETER 107 DEHUMID DEADBAND: 3 (DEFAULT) THIS IS THE ACTUAL +/- VALUE Pass

**Comment:**

PARAMETER 117 CO2 DAMPER MAX OPEN: 50% Pass

**Comment:**

PARAMETER 118 CO2 START OPEN PPM: 1200 Pass

**Comment:**

PARAMETER 119 CO2 FULL OPEN PPM: 1500 Pass

**Comment:**

PARAMETER 137 OCCHET SET POINT: 68 (BACK UP) Pass

**Comment:**

PARAMETER 139 OCC COOLING SET POINT: 72 (BACK UP) Pass

**Comment:**

PARAMETER 154 OCC BLOWER MODE: ON-CONTINUOUS 1 Pass

**Comment:**

PARAMETER 131 SET TO THE SAME % AS THE MINMIUM OA DAMPER SETPOINT Pass

**Comment:**

RTU-1: 24% RTU-2: 26% RTU-3: 28%

**CFM VALUES / MSAV FAN SPEEDS (AIR BALANCER TO DEFINE / IF APPLICABLE):**

OA DAMPER SET TO SAME POSITION IN ALL FAN SPEEDS? Pass

**Comment:**

ALL FAN SPEEDS SET TO THE SAME CFM VALUE (ENTER SETPOINTS BELOW) Pass

**Comment:**

RTU-1 70%/RTU-2 82%/RTU-3 62%

HEAT CFM VALUE: PER THE HVAC SCHEDULE Pass

**Comment:**

PERCENTAGES, NOT CFM VALUES. RTU-1 70/ RTU-2 82/ RTU-3 62

---

HIGH COOL CFM VALUE: THE HIGH COOL CFM VALUE

Pass

**Comment:**

RTU-1 70/ RTU-2 82/ RTU-3 62

---

LOW COOL CFM VALUE: MATCH THE HIGH COOL CFM VALUE

Pass

**Comment:**

RTU-1 70/ RTU-2 82/ RTU-3 62

---

VENTILATION CFM VALUE: MATCH THE HIGH COOL CFM VALUE

Pass

**Comment:**

RTU-1 70/ RTU-2 82/ RTU-3 62

---



### 03-11-24 WAWA #5801 - FAIRHOPE, AL

#### CheckList Information

**Name :** TECH - 3 SENSOR WIRING (LENNOX) **Status :** Completed  
**Assigned Organization :** National TAB **Asset :**  
**Requesting Organization :** National TAB  
**Created Date :** 03/11/2024 - Brianna Biggs - National TAB  
**Completed Date :** 03/13/2024 - Gabe Merk - National TAB

#### CheckList Item Details

##### COMBINATION TEMPERATURE/HUMIDITY SENSOR

Sensors are installed where shown on the drawing? Pass

**Comment:**

2 conductor shielded cable has one wire landed to Vin, one to GND, and the shield wire is not connected. Fail

**Comment:**

For second shielded cable, one wire is landed to Vout and the shield wire is not connected. Fail

**Comment:**

Verify that the CORE or Prodigy controller is sensing a relative humidity (record the reading) Pass

**Comment:**

Rtu 1:49% Rtu 2: 51% Rtu 3: 52%



### 03-11-24 WAWA #5801 - FAIRHOPE, AL

#### CheckList Information

**Name :** TECH - 4 EF'S **Status :** Not Completed  
**Assigned Organization :** National TAB **Asset :**  
**Requesting Organization :** National TAB  
**Created Date :** 03/11/2024 - Brianna Biggs - National TAB

#### CheckList Item Details

**EF's**

Rotation is correct?	Pass
----------------------	------

**Comment:**

Belts are tight (if applicable)?	N/A
----------------------------------	-----

**Comment:**

Speed controller installed and functional (if applicable)?	Pass
--	------

**Comment:**

NOT INITIALLY INSTALLED. (RESOLVED)

There is no major leakage around base of fan?	Pass
---	------

**Comment:**

DUCT INSTALLATION NOT COMPLETED AT BASE OF THE FAN INITIALLY (RESOLVED)

Is the motor operating below the motor FLA rating?	Fail
--	------

**Comment:**

4.5/3.2. MOTOR IS THERMALLY PROTECTED AND RAN FOR THE DURATION OF TESTING.

Back draft damper installed and can it fully open?	Fail
--	------

**Comment:**

NOT INSTALLED INITIALLY (RESOLVED)

---

Unit free of noticeable noise and vibration?

Pass

---

**Comment:**

---

Total exhaust flow balanced within +/-5% and grilles are within +/-10%?

Pass

---

**Comment:**

---



### 03-11-24 WAWA #5801 - FAIRHOPE, AL

#### CheckList Information

**Name :** TECH - 5 CLOSEOUT CHECKS **Status :** Completed

**Assigned Organization :** National TAB **Asset :**

**Requesting Organization :** National TAB

**Created Date :** 03/11/2024 - Brianna Biggs - National TAB

**Completed Date :** 03/13/2024 - Gabe Merk - National TAB

#### CheckList Item Details

##### SPACE COMFORT

Is space free of drafting? Pass

**Comment:**

Is space comfortable in all areas? Pass

**Comment:**

Is the space free of ventilation noise? Pass

**Comment:**

##### BUILDING PRESSURE

Do actual net building airflow, design net building airflow, and pressure coincide? If not why? (All three should either be positive or negative) Pass

**Comment:**



### 03-11-24 WAWA #5801 - FAIRHOPE, AL

#### CheckList Information

**Name :** TECH - SITE PICTURES **Status :** Completed  
**Assigned Organization :** National TAB **Asset :**  
**Requesting Organization :** National TAB  
**Created Date :** 03/11/2024 - Brianna Biggs - National TAB  
**Completed Date :** 03/13/2024 - Gabe Merk - National TAB

#### CheckList Item Details

STORE FRONT

**Comment:**



image  
03/11/2024

RTU-1

**Comment:**



**2503E482\_CFFB\_4E16\_8B..  
03/11/2024**

---

RTU-2

**Comment:**



**FFBEC355\_4FDA\_4BF9\_B3..  
03/11/2024**

---

RTU-3

**Comment:**



9A26A419\_FC77\_48C7\_B8..  
03/11/2024

---

EF-1

Comment:



43A83855\_26BA\_4A56\_98..  
03/11/2024

---

EF-2

Comment:



**1F78055A\_C741\_4BBC\_88..**  
**03/13/2024**

# National TAB

Project: 03-11-24 WAWA #5801 - FAIRHOPE, AL

System/Unit: AHU/RTU



Asset: RTU1

AREA:RETAIL

Unit Data		
	Design	Actual
MFG	LENNOX	LENNOX
Serial Num	-	5623J05052
Model Num	LCT102H4E	LCT102H4E
Type	RTU	RTU
Configuration	VERTICAL	VERTICAL
Num OA Filters 1	-	2
OA Filter Size 1	-	16"x25"
Num Final Filter 1	-	4
Final Filter Size 1	-	20"x25"x2"

Motor Data		
	Design	Actual
Motor MFG	-	EBMPABST
Horsepower	3.75	3.75
Phase	3	3
Rated Voltage	208	208
Rated Amperage	-	8.7

Test Data		
	Design	Actual
SF CFM	3400	3416
RA CFM	2900	2908
OA CFM	500	508
RL Voltage	-	207/207/209
RL Amperage	-	3.8/3.7/3.9
SF System SetPt	-	70%
OA Damper Position	-	24%
OA Damper Type	-	ECONOMIZER

Performance Data		
	Design	Actual
MA Plenum SP	-	-0.77"
Fan Suction SP	-	-1.03"
Fan Discharge SP	-	0.38"
Total ESP	0.5"	1.15"
Fan Total SP	-	1.41"

Completed By: Gabe Merk on 03/13/2024

# National TAB

Project:03-11-24 WAWA #5801 - FAIRHOPE, AL

## AHU/RTU



### Diffuser Supply (GRD)

#### RTU1/RETAIL

Asset									
Asset Name	Location	Type	Size	DESIGN CFM	AK	CFM(1)	CFM(2)	FINAL CFM	% to design
SGRD1	OFFICE	CD1	8"	150	1	219	146	150	100.0
SGRD2	ASSOCIATES	CD1	8"	150	1	234	169	165	110.0
SGRD3	RETAIL	LD1	10"	300	1	72	290	321	107.0
SGRD4	RETAIL	LD1	10"	300	1	75	272	297	99.0
SGRD5	RETAIL	LD1	10"	300	1	410	316	330	110.0
SGRD6	RETAIL	LD1	10"	325	1	516	390	293	90.2
SGRD7	RETAIL	LD1	10"	325	1	454	367	309	95.1
SGRD8	RETAIL	LD1	10"	300	1	326	270	291	97.0
SGRD9	RETAIL	LD1	10"	290	1	309	267	270	93.1
SGRD10	DELIVERY VESTIBULE	CD1	8"	200	1	247	193	193	96.5
SGRD11	RETAIL	LD1	10"	280	1	350	292	308	110.0
SGRD12	RETAIL	LD1	10"	280	1	104	246	287	102.5
SGRD13	MENS RR	CD3	6"	50	1	138	95	54	108.0
SGRD14	WOMENS RR	CD3	6"	50	1	155	100	50	100.0
SGRD15	REAR VESTIBULE	CD3	6"	100	1	19	80	98	98.0
Total				3400		3628	3493	3416	100.47%

### Diffuser Ret/Exh (GRD)

#### RTU1/RETAIL

Asset									
Asset Name	Location	Type	Size	DESIGN CFM	AK	CFM(1)	CFM(2)	FINAL CFM	% to design
EGRD1	RETAIL	G1	14"	695	1	1111	871	670	96.4
EGRD2	RETAIL	G1	14"	695	1	105	744	717	103.2
EGRD3	RETAIL	G1	14"	700	1	179	707	770	110.0
EGRD4	RETAIL	G1	14"	700	1	1259	643	765	109.3
Total				2790		2654	2965	2922	104.73%

Completed By: Gabe Merk on 03/13/2024

# National TAB

Project: 03-11-24 WAWA #5801 - FAIRHOPE, AL

## System/Unit: AHU/RTU



Asset: RTU2

AREA:FOOD SERVICE

Unit Data		
	Design	Actual
MFG	LENNOX	LENNOX
Serial Num	-	5623J07566
Model Num	LCT120H4E	LCT120H4E
Type	RTU	RTU
Configuration	VERTICAL	VERTICAL
Num OA Filters 1	-	2
OA Filter Size 1	-	16"x25"
Num Final Filter 1	-	4
Final Filter Size 1	-	20"x25"x2"

Motor Data		
	Design	Actual
Motor MFG	-	EBMPABST
Horsepower	3.75	3.75
Phase	3	3
Rated Voltage	208	208
Rated Amperage	-	8.7

Test Data		
	Design	Actual
SF CFM	4000	4126
RA CFM	3350	3491
OA CFM	650	635
RL Voltage	-	207/207/208
RL Amperage	-	5.8/5.9/5.8
SF System SetPt	-	82%
OA Damper Position	-	26%
OA Damper Type	-	ECONOMIZER

Performance Data		
	Design	Actual
MA Plenum SP	-	-0.89"
Fan Suction SP	-	-1.14"
Fan Discharge SP	-	0.80"
Total ESP	0.5"	1.69"
Fan Total SP	-	1.94"

Completed By: Gabe Merk on 03/13/2024

Notes:  
Restrictive ductwork on R-1. Unable to hit design flow.

Written By: Gabe Merk on 03/13/2024

# National TAB

Project:03-11-24 WAWA #5801 - FAIRHOPE, AL

## AHU/RTU



### Diffuser Supply (GRD)

#### RTU2/FOOD SERVICE

Asset									
Asset Name	Location	Type	Size	DESIGN CFM	AK	CFM(1)	CFM(2)	FINAL CFM	% to design
RTU2-SGRD1	FOOD SERVICE 1	LD1	10"	400	1	554	487	432	108.0
RTU2-SGRD2	FOOD SERVICE 1	LD1	10"	400	1	416	400	400	100.0
RTU2-SGRD3	FOOD SERVICE 1	LD1	10"	400	1	568	527	385	96.3
RTU2-SGRD4	FOOD SERVICE 2	LD1	12"	500	1	144	106	531	106.2
RTU2-SGRD5	FOOD SERVICE 2	LD1	12"	500	1	174	554	530	106.0
RTU2-SGRD6	FOOD SERVICE 2	LD1	12"	500	1	646	584	506	101.2
RTU2-SGRD7	BACKROOM	CD1	10"	300	1	453	412	297	99.0
RTU2-SGRD8	WASH ROOM	LD1	10"	400	1	453	454	437	109.3
RTU2-SGRD9	STAGING	CD1	6"	50	1	121	98	48	96.0
RTU2-SGRD10	ELECTRICAL ROOM	CD1	12"	550	1	632	584	560	101.8
Total				4000		4161	4206	4126	103.15%

### Diffuser Ret/Exh (GRD)

#### RTU2/FOOD SERVICE

Asset									
Asset Name	Location	Type	Size	DESIGN CFM	AK	CFM(1)	CFM(2)	FINAL CFM	% to design
EGRD1	FOOD SERVICE 2	G1	12"	580	1	480	379	447	77.1
EGRD2	FOOD SERVICE 2	G1	12"	585	1	617	492	569	97.3
EGRD3	FOOD SERVICE 2	G1	12"	585	1	64	631	586	100.2
EGRD4	FOOD SERVICE 1	G1	14"	800	1	1107	928	850	106.3
EGRD5	BACKROOM	G1	14"	800	1	1045	882	760	95.0
Total				3350		3313	3312	3212	95.88%

# National TAB

Project: 03-11-24 WAWA #5801 - FAIRHOPE, AL

## System/Unit: AHU/RTU



Asset: RTU3

AREA:RETAIL

Unit Data		
	Design	Actual
MFG	LENNOX	LENNOX
Serial Num	-	5623J07567
Model Num	LCT092H4E	LCT092H4E
Type	RTU	RTU
Configuration	VERTICAL	VERTICAL
Num OA Filters 1	-	2
OA Filter Size 1	-	16"x25"
Num Final Filter 1	-	4
Final Filter Size 1	-	20"x25"x2"

Motor Data		
	Design	Actual
Motor MFG	-	EBMPABST
Horsepower	3.75	3.75
Phase	3	3
Rated Voltage	208	208
Rated Amperage	-	8.7

Test Data		
	Design	Actual
SF CFM	3000	3054
RA CFM	2550	2589
OA CFM	450	465
RL Voltage	-	206/207/207
RL Amperage	-	2.8/2.8/3.0
SF System SetPt	-	62%
OA Damper Position	-	28%
OA Damper Type	-	ECONOMIZER

Performance Data		
	Design	Actual
MA Plenum SP	-	-0.43"
Fan Suction SP	-	-0.60"
Fan Discharge SP	-	0.56"
Total ESP	0.5"	0.99"
Fan Total SP	-	1.16"

Completed By: Gabe Merk on 03/14/2024

# National TAB

Project:03-11-24 WAWA #5801 - FAIRHOPE, AL

## AHU/RTU



### Diffuser Supply (GRD)

#### RTU3/RETAIL

Asset									
Asset Name	Location	Type	Size	DESIGN CFM	AK	CFM(1)	CFM(2)	FINAL CFM	% to design
RTU3-SGRD1	FRONT VESTIBULE	CD2	12"	600	1	559	480	585	97.5
RTU3-SGRD2	RETAIL AREA	LD1	10"	300	1	335	278	328	109.3
RTU3-SGRD3	RETAIL AREA	LD1	10"	300	1	490	407	297	99.0
RTU3-SGRD4	COFFEE/SPECIALTY BEVERAGE	LD1	10"	300	1	98	200	278	92.7
RTU3-SGRD5	COFFEE/SPECIALTY BEVERAGE	LD1	10"	300	1	130	250	323	107.7
RTU3-SGRD6	RETAIL	LD1	10"	300	1	438	376	323	107.7
RTU3-SGRD7	RETAIL	LD1	10"	300	1	358	286	322	107.3
RTU3-SGRD8	RETAIL	LD1	10"	300	1	482	407	299	99.7
RTU3-SGRD9	RETAIL	LD1	10"	300	1	456	400	299	99.7
Total				3000		3346	3084	3054	101.8%

### Diffuser Ret/Exh (GRD)

#### RTU3/RETAIL

Asset									
Asset Name	Location	Type	Size	DESIGN CFM	AK	CFM(1)	CFM(2)	FINAL CFM	% to design
EGRD1	RETAIL	G1	14"	870	1	818	818	818	94.0
EGRD2	RETAIL	G1	14"	870	1	764	764	764	87.8
EGRD3	RETAIL	G1	14"	870	1	775	775	775	89.1
Total				2610		2357	2357	2357	90.31%

Completed By: Gabe Merk on 03/13/2024

# National TAB

Project: 03-11-24 WAWA #5801 - FAIRHOPE, AL

## System/Unit: FAN - Exhaust



Asset: EF1

AREA:FOOD SERVICE

Unit Data		
	Design	Actual
MFG	GREENHECK	GREENHECK
Model Num	G-140	G-140
Serial Num	-	23134128
Type	DOWNBLAST	DOWNBLAST
Configuration	VERTICAL	VERTICAL

Motor Data		
	Design	Actual
Motor MFG	-	NOT LISTED
Frame	-	48Y
Horsepower	1/4	1/4
Motor Rpm	-	1140
Phase	1	1
Voltage (rated)	120	115
Amperage (rated)	-	3.2
Service Factor	-	1.00

Test Data		
	Design	Actual
CFM	1150	1190
Fan Rotation	-	CW
System SetPt	-	Dial on W
RL Voltage	-	94
RL Amperage	-	4.5
Total ESP	0.250"	0.86"
Fan Inlet SP	-	-0.86"
Fan Discharge SP	-	ATM

Completed By: Gabe Merk on 03/13/2024

# National TAB

Project:03-11-24 WAWA #5801 - FAIRHOPE, AL

## FAN - Exhaust



### Diffuser Supply (GRD)

#### EF1/FOOD SERVICE

Asset									
Asset Name	Location	Type	Size	DESIGN CFM	AK	CFM(1)	CFM(2)	FINAL CFM	% to design
EF1-SGRD1	STAGING	G1	6"	100	1	125	110	110	110.0
EF1-SGRD2	FOOD SERVICE 1	G1	6"	300	1	350	298	298	99.3
EF1-SGRD3	FOOD SERVICE 1	G1	6"	500	1	668	546	546	109.2
EF1-SGRD4	MENS RR	G1	6"	100	1	98	77	91	91.0
EF1-SGRD5	MENS RR	G3	6"	50	1	121	85	55	110.0
EF1-SGRD6	WOMENS RR	G3	6"	100	1	89	75	90	90.0
Total				1150		1451	1191	1190	103.48%

Completed By: Gabe Merk on 03/13/2024

# National TAB

Project: 03-11-24 WAWA #5801 - FAIRHOPE, AL

## System/Unit: FAN - Exhaust



Asset: EF2

AREA:

Unit Data		
	Design	Actual
MFG	GREENHECK	GREENHECK
Model Num	CSP-A110	CSP-A110
Serial Num	-	23131609
Type	INLINE	INLINE
Configuration	HORIZONTAL	HORIZONTAL

Test Data		
	Design	Actual
CFM	50	51
System SetPt	-	100%

Motor Data		
	Design	Actual
Horsepower	21W	NL
Motor Rpm	-	NL
Phase	1	1
Voltage (rated)	120	115
Amperage (rated)	-	NL

Completed By: Gabe Merk on 03/14/2024

1 HVAC FLOOR PLAN  
1/4" = 1'-0"

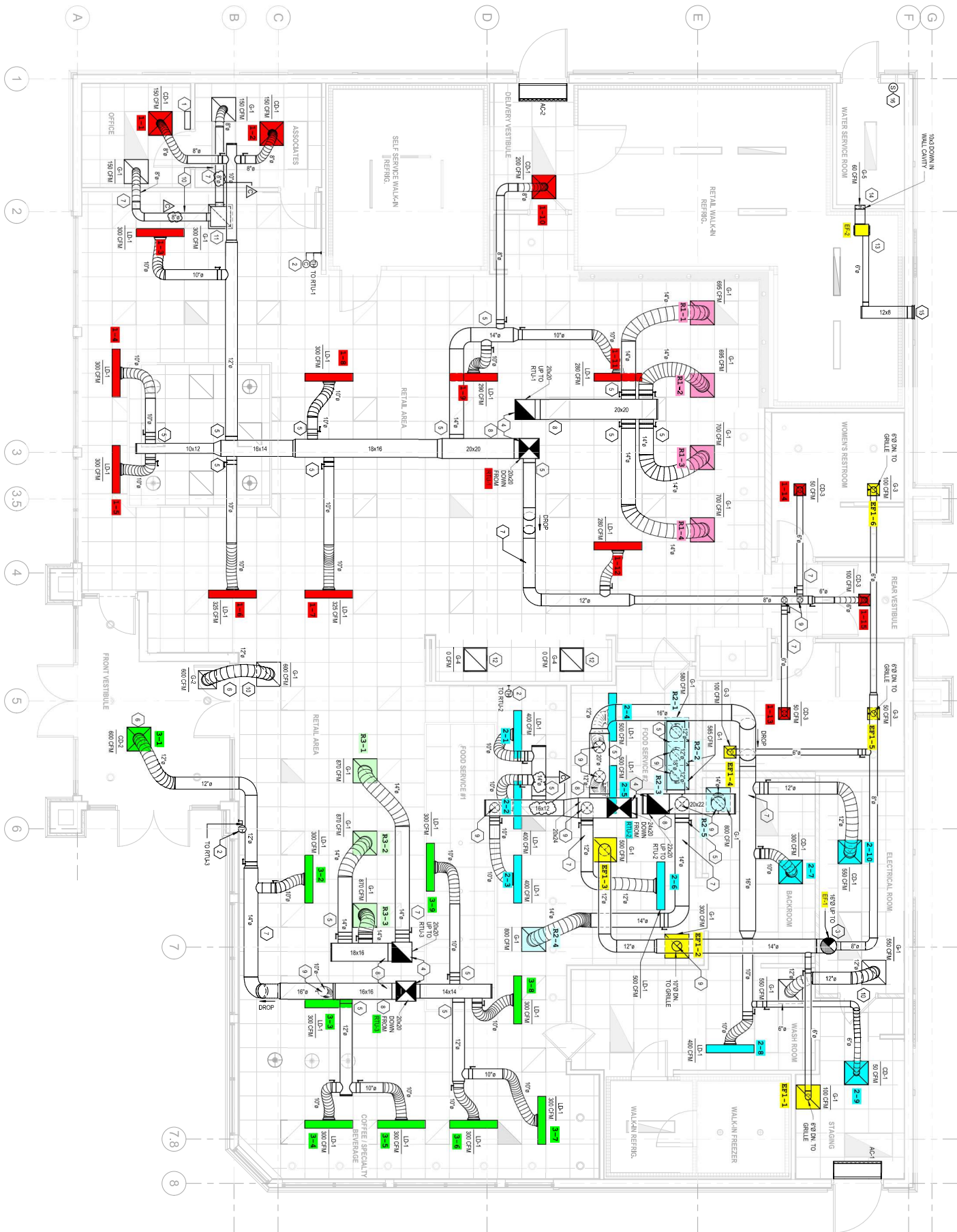

### AIR BALANCE SCHEDULE

UNIT	AREA SERVED	HVAC SUPPLY		HVAC RETURN		HVAC OUTDOOR		OA %		HOOD MAKE-UP		HOOD EXHAUST		GENERAL EXH.	
		DESIGN	ACTUAL	DESIGN	ACTUAL	DESIGN	ACTUAL	DESIGN	ACTUAL	DESIGN	ACTUAL	DESIGN	ACTUAL	DESIGN	ACTUAL
RTU-1	RETAIL	3400	3416	2900	2908	500	508	14.7%	14.9%						
RTU-2	FOOD SERVICE	4000	4126	3350	3491	650	635	16.3%	15.4%						
RTU-3	RETAIL	3000	3054	2550	2589	450	465	15.0%	15.2%						
EF-1	FOOD SERVICE													1150	1190
EF-2	WATER ROOM													60	51
<b>TOTALS</b>		10400	10596	8800	8988	1600	1608			0	0	0	0	1210	1241

#### NET BUILDING AIRFLOW CALCULATION

TOTALS	DESIGN	ACTUAL
TOTAL OA	1600	1608
TOTAL EXHAUST	1210	1241
<b>NET AIRFLOW</b>	<b>390</b>	<b>367</b>

DOOR TESTED	BUILDING PRESSURE MEASUREMENTS (IN. H2O)
FRONT	0.01
SIDE	0.01
REAR	0.01
<b>AVERAGE</b>	<b>0.01</b>

#### FINAL CHECKS

- ACTUAL NET AIRFLOW COINCIDES WITH DESIGN: ✓

---

- MEASURED PRESSURES COINCIDES WITH ACTUAL NET AIRFLOW: ✓

---

- PRESSURE FALLS WITHIN IMC TOLERANCE OF +/-0.02" W.C. ✓

NOTES: